

100V/1A Peak, Low Cost, High Frequency Half Bridge Driver

The HIP2106 is a high frequency, 100V Half Bridge N-Channel MOSFET driver IC, available in 8 lead plastic SOIC. The low-side and high-side gate drivers are independently controlled and matched to 8ns. This gives the user maximum flexibility in dead-time selection and driver protocol. Undervoltage protection on both the low-side and high-side supplies force the outputs low. An on-chip diode eliminates the discrete diode required with other driver ICs. A new levelshifter topology yields the low-power benefits of pulsed operation with the safety of DC operation. Unlike some competitors, the high-side output returns to its correct state after a momentary undervoltage of the high-side supply.

Ordering Information

PART NUMBER	TEMP. RANGE (°C)	PACKAGE	PKG. NO.
HIP2106IB	-40 to 85	8 Ld SOIC	M8.15
HIP2106IP	-40 to 85	8 Ld PDIP	E8.3

Pinout

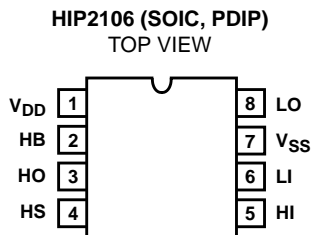

Features

- Drives N-Channel MOSFET Half Bridge
- Space Saving SO8 Package
- Bootstrap Supply Max Voltage to 116V_{DC}
- On-Chip 1Ω Bootstrap Diode
- Fast Propagation Times Needed for Multi-MHz Circuits
- Drives 1000pF Load at 500kHz with Rise and Fall Times of Typically 20ns
- CMOS Input Thresholds for Improved Noise Immunity
- Independent Inputs for Non-Half Bridge Topologies
- No Start-Up Problems
- Outputs Unaffected by Supply Glitches, HS Ringing Below Ground, or HS Slewing at High dv/dt
- Low Power Consumption
- Wide Supply Range
- Supply Undervoltage Protection
- 3Ω Output Resistance

Applications

- Telecom Half Bridge Power Supplies
- Avionic DC-DC Converters
- Two-Switch Forward Converters
- Active Clamp Forward Converters

Application Block Diagram

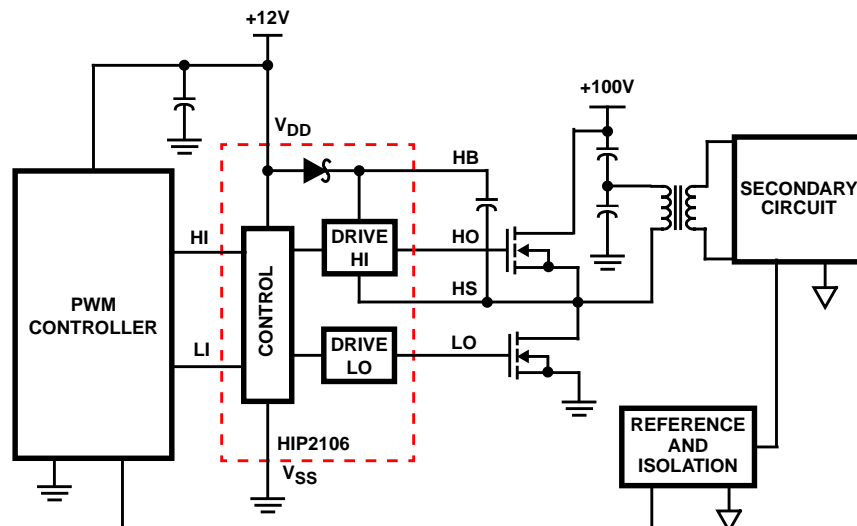

Functional Block Diagram

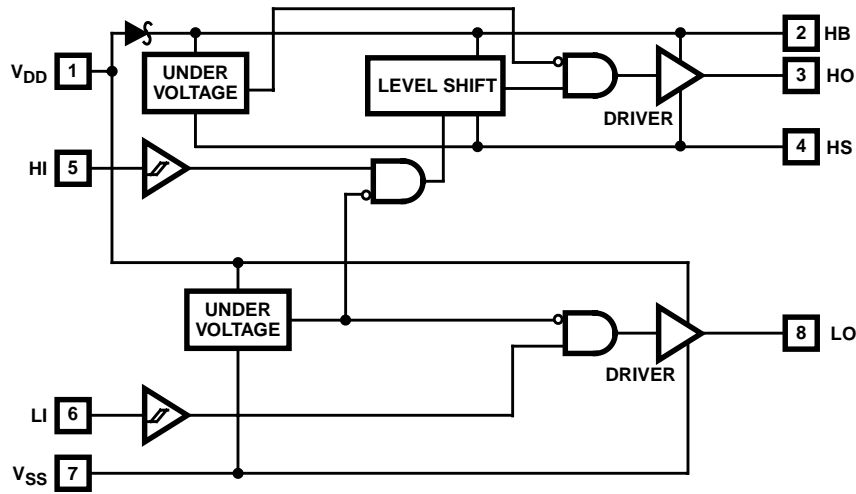

Other Applications

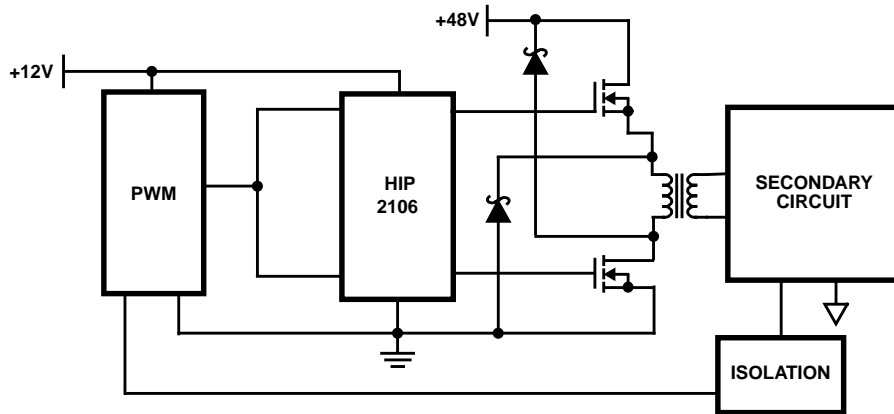

FIGURE 1. TWO-SWITCH FORWARD CONVERTER

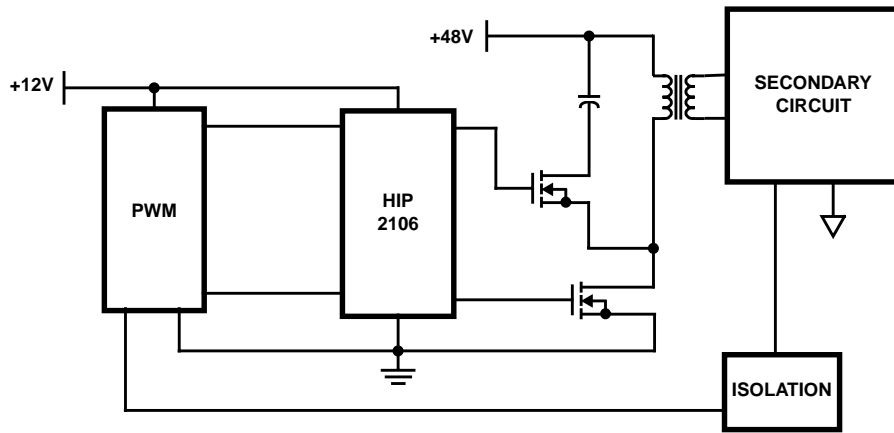

FIGURE 2. FORWARD CONVERTER WITH AN ACTIVE CLAMP

Absolute Maximum Ratings

Supply Voltage, V_{DD} , $V_{HB}-V_{HS}$	-0.3V to 18V
LI and HI Voltages	-3V to $V_{DD} + 0.3V$
Voltage on LO	-0.3V to $V_{DD} + 0.3V$
Voltage on HO	$V_{HS} - 0.3V$ to $V_{HB} + 0.3V$
Voltage on HS (Continuous)	-1V to 110V
Voltage on HB	+118V
Average Current in V_{DD} to HB Diode.....	100mA
ESD Classification	Class 1 (1kV)

Thermal Information

Thermal Resistance (Typical, Note 1)	θ_{JA} (°C/W)
SOIC Package	160
PDIP Package	100
HS Slew Rate	10V/ns
Maximum Power Dissipation at 25°C in Free Air780mW
Maximum Storage Temperature Range	-65°C to 150°C
Maximum Junction Temperature Range	-55°C to 150°C
Maximum Lead Temperature (Soldering 10s)	300°C
(Lead Tips Only)	

Recommended Operating Conditions

Supply Voltage, V_{DD}	+9V to +16.5V
Voltage on HS	-1V to 100V

Voltage on HS	(Repetitive Transient) -5V to 105V
Voltage on HB... $V_{HS} + 8V$ to $V_{HS} + 16.5V$ and $V_{DD} - 1V$ to $V_{DD} + 100V$	

CAUTION: Stresses above those listed in "Absolute Maximum Ratings" may cause permanent damage to the device. This is a stress only rating and operation of the device at these or any other conditions above those indicated in the operational sections of this specification is not implied.

NOTES:

- θ_{JA} is measured with the component mounted on an evaluation PC board in free air.
- All Voltages Relative to Pin 4, V_{SS} Unless Otherwise Specified.

Electrical Specifications $V_{DD} = V_{HB} = 12V$, $V_{SS} = V_{HS} = 0V$, No Load on LO or HO, Unless Otherwise Specified

PARAMETER	SYMBOL	TEST CONDITIONS	$T_J = 25^\circ C$			$T_J = -40^\circ C$ TO $125^\circ C$		UNITS
			MIN	TYP	MAX	MIN	MAX	
SUPPLY CURRENTS								
V_{DD} Quiescent Current	I_{DD}	LI = HI = 0V	-	0.1	0.15	-	0.2	mA
V_{DD} Operating Current	I_{DDO}	f = 500kHz	-	1.5	2.5	-	3	mA
Total HB Quiescent Current	I_{HB}	LI = HI = 0V	-	0.1	0.15	-	0.2	mA
Total HB Operating Current	I_{HBO}	f = 500kHz	-	1.5	2.5	-	3	mA
HB to V_{SS} Current, Quiescent	I_{HBS}	$V_{HS} = V_{HB} = 116.5V$	-	0.05	1	-	10	μA
HB to V_{SS} Current, Operating	I_{HBSO}	f = 500kHz	-	0.7	-	-	-	mA
INPUT PINS								
Low Level Input Voltage Threshold	V_{IL}		4	5.4	-	3	-	V
High Level Input Voltage Threshold	V_{IH}		-	5.8	8	-	9	V
Input Voltage Hysteresis	V_{IHYS}		-	0.4	-	-	-	V
Input Pulldown Resistance	R_I		-	200	-	100	500	k Ω
UNDER VOLTAGE PROTECTION								
V_{DD} Rising Threshold	V_{DDR}		7	7.3	8	6.5	8.5	V
V_{DD} Threshold Hysteresis	V_{DDH}		-	0.5	-	-	-	V
HB Rising Threshold	V_{HBR}		6.5	6.9	7.5	6	8	V
HB Threshold Hysteresis	V_{HBH}		-	0.4	-	-	-	V
BOOT STRAP DIODE								
Low-Current Forward Voltage	V_{DL}	$I_{VDD-HB} = 100\mu A$	-	0.45	0.55	-	0.7	V
High-Current Forward Voltage	V_{DH}	$I_{VDD-HB} = 100mA$	-	0.7	0.8	-	1	V
Dynamic Resistance	R_D	$I_{VDD-HB} = 100mA$	-	0.8	1	-	1.5	Ω
LO GATE DRIVER								
Low Level Output Voltage	V_{OLL}	$I_{LO} = 100mA$	-	0.25	0.3	-	0.4	V
High Level Output Voltage	V_{OHL}	$I_{LO} = -100mA$, $V_{OHL} = V_{DD} - V_{LO}$	-	0.25	0.3	-	0.4	V
Peak Pullup Current	I_{OHL}	$V_{LO} = 0V$	-	1	-	-	-	A
Peak Pulldown Current	I_{OLL}	$V_{LO} = 12V$	-	1	-	-	-	A
HO GATE DRIVER								
Low Level Output Voltage	V_{OLH}	$I_{HO} = 100mA$	-	0.25	0.3	-	0.4	V
High Level Output Voltage	V_{OHH}	$I_{HO} = -100mA$, $V_{OHH} = V_{HB} - V_{HO}$	-	0.25	0.3	-	0.4	V
Peak Pullup Current	I_{OHH}	$V_{HO} = 0V$	-	1	-	-	-	A

HIP2106

Electrical Specifications $V_{DD} = V_{HB} = 12V$, $V_{SS} = V_{HS} = 0V$, No Load on LO or HO, Unless Otherwise Specified (Continued)

PARAMETER	SYMBOL	TEST CONDITIONS	$T_J = 25^\circ C$			$T_J = -40^\circ C$ TO $125^\circ C$		UNITS
			MIN	TYP	MAX	MIN	MAX	
Peak Pulldown Current	I_{OLH}	$V_{HO} = 12V$	-	1	-	-	-	A

Switching Specifications $V_{DD} = V_{HB} = 12V$, $V_{SS} = V_{HS} = 0V$, No Load on LO or HO, Unless Otherwise Specified

PARAMETER	SYMBOL	TEST CONDITIONS	$T_J = 25^\circ C$			$T_J = -40^\circ C$ TO $125^\circ C$		UNITS
			MIN	TYP	MAX	MIN	MAX	
Lower Turn-Off Propagation Delay (LI Falling to LO Falling)	t_{LPHL}		-	40	70	-	90	ns
Upper Turn-Off Propagation Delay (HI Falling to HO Falling)	t_{HPLH}		-	40	70	-	90	ns
Lower Turn-On Propagation Delay (LI Rising to LO Rising)	t_{LPLH}		-	40	70	-	90	ns
Upper Turn-On Propagation Delay (HI Rising to HO Rising)	t_{HPLH}		-	40	70	-	90	ns
Delay Matching: Lower Turn-On and Upper Turn-Off	t_{MON}		-	4	16	-	20	ns
Delay Matching: Lower Turn-Off and Upper Turn-On	t_{MOFF}		-	4	16	-	20	ns
Either Output Rise/Fall Time	t_{RC} , t_{FC}	$C_L = 1000pF$	-	20	-	-	-	ns
Either Output Rise/Fall Time (3V to 9V)	t_R , t_F	$C_L = 0.1\mu F$	-	1.0	1.2	-	1.6	us
Either Output Rise Time Driving DMOS	t_{RD}	$C_L = IRFR120$	-	40	-	-	-	ns
Either Output Fall Time Driving DMOS	t_{FD}	$C_L = IRFR120$	-	20	-	-	-	ns
Minimum Input Pulse Width that Changes the Output	t_{PW}		-	-	-	-	100	ns
Bootstrap Diode Turn-On or Turn-Off Time	t_{BS}		-	20	-	-	-	ns

Pin Descriptions

PIN NUMBER	SYMBOL	DESCRIPTION
1	V_{DD}	Positive Supply to lower gate drivers. De-couple this pin to V_{SS} (Pin 7). Bootstrap diode connected to HB (pin 2).
2	HB	High-Side Bootstrap supply. External bootstrap capacitor is required. Connect positive side of bootstrap capacitor to this pin. Bootstrap diode is on-chip.
3	HO	High-Side Output. Connect to gate of High-Side power MOSFET.
4	HS	High-Side Source connection. Connect to source of High-Side power MOSFET. Connect negative side of bootstrap capacitor to this pin.
5	HI	High-Side input.
6	LI	Low-Side input.
7	V_{SS}	Chip negative supply, generally will be ground.
8	LO	Low-Side Output. Connect to gate of Low-Side power MOSFET.

Timing Diagrams

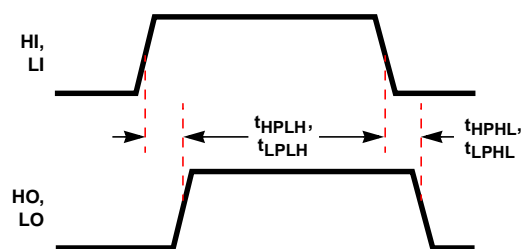

FIGURE 3.

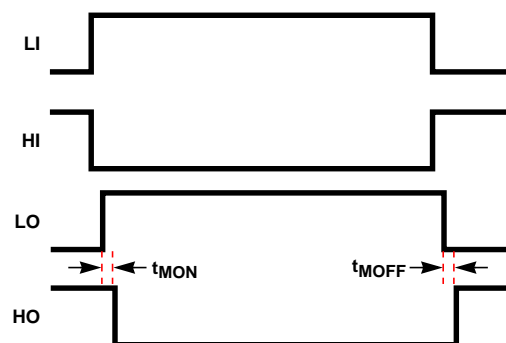

FIGURE 4.

Typical Performance Curves

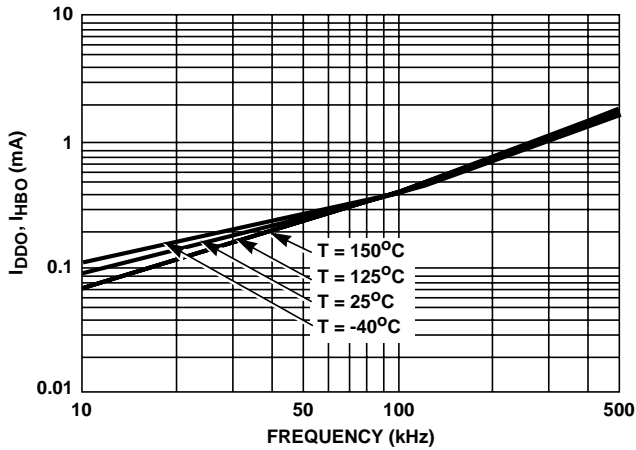

FIGURE 5. OPERATING CURRENT vs FREQUENCY

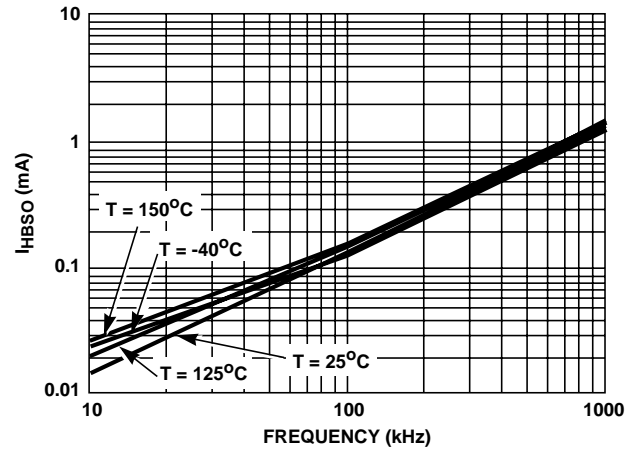

FIGURE 6. LEVEL SHIFTER CURRENT vs FREQUENCY

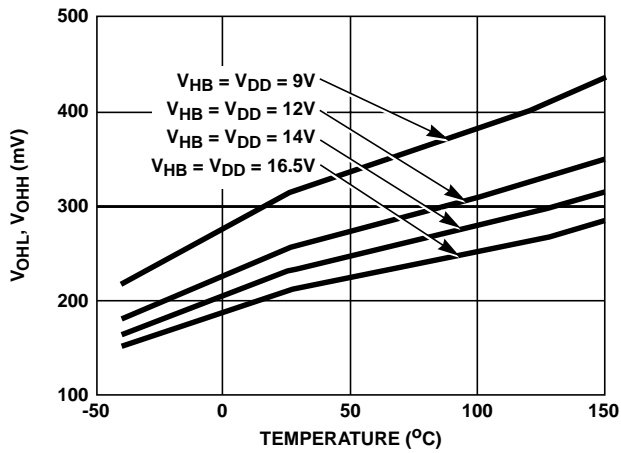

FIGURE 7. HIGH LEVEL OUTPUT VOLTAGE vs TEMPERATURE

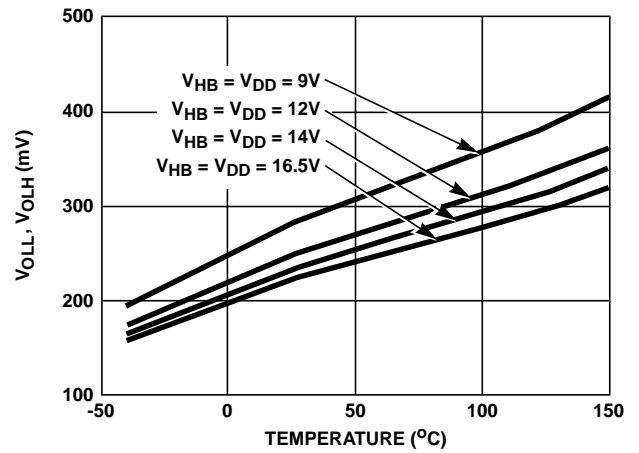

FIGURE 8. LOW LEVEL OUTPUT VOLTAGE vs TEMPERATURE

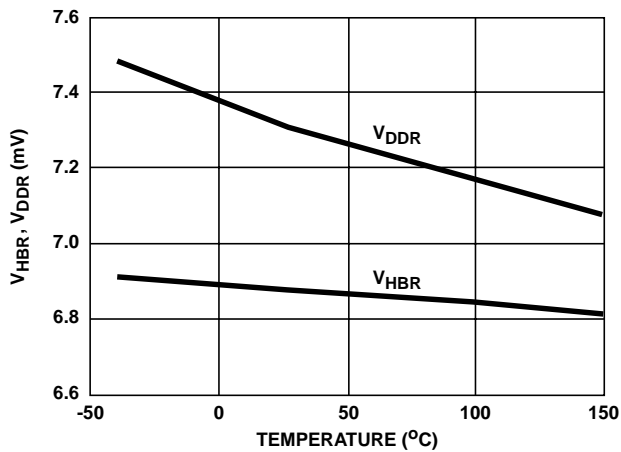

FIGURE 9. UNDERVOLTAGE LOCKOUT THRESHOLD vs TEMPERATURE

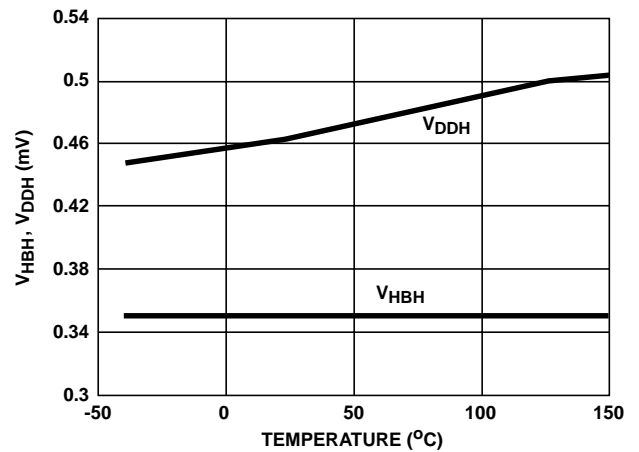

FIGURE 10. UNDERVOLTAGE LOCKOUT HYSTERESIS vs TEMPERATURE

Typical Performance Curves (Continued)

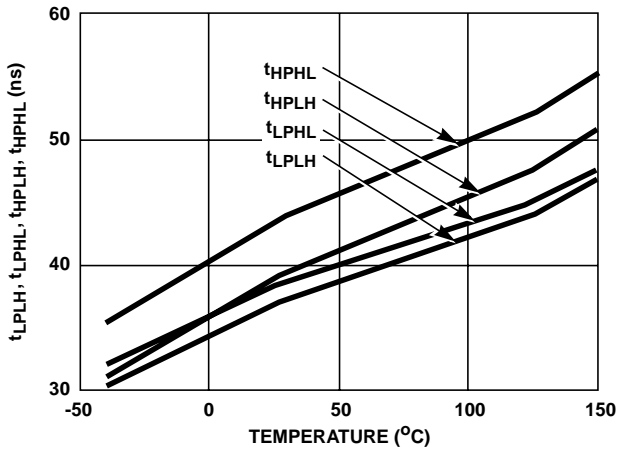

FIGURE 11. PROPAGATION DELAYS vs TEMPERATURE

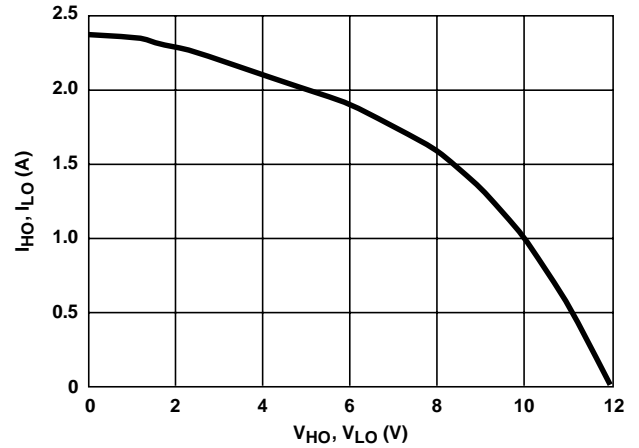

FIGURE 12. PULLUP CURRENT vs OUTPUT VOLTAGE

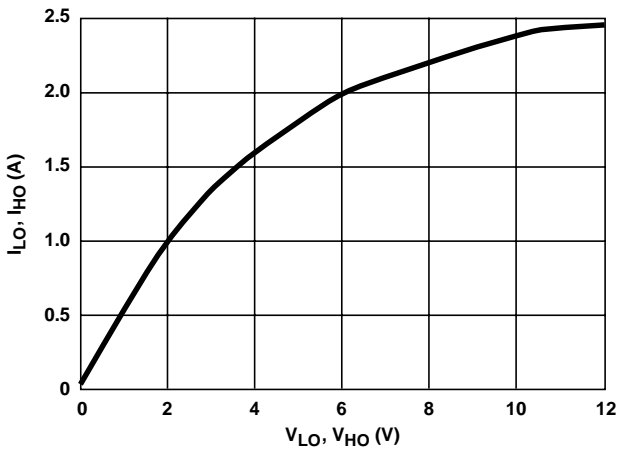

FIGURE 13. PULLDOWN CURRENT vs OUTPUT VOLTAGE

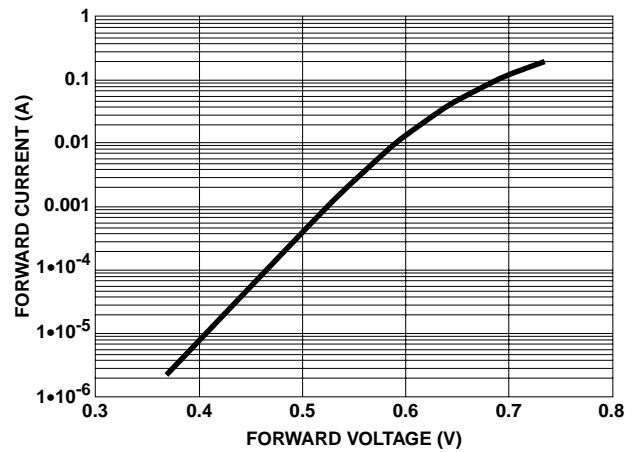

FIGURE 14. BOOTSTRAP DIODE I-V CHARACTERISTICS

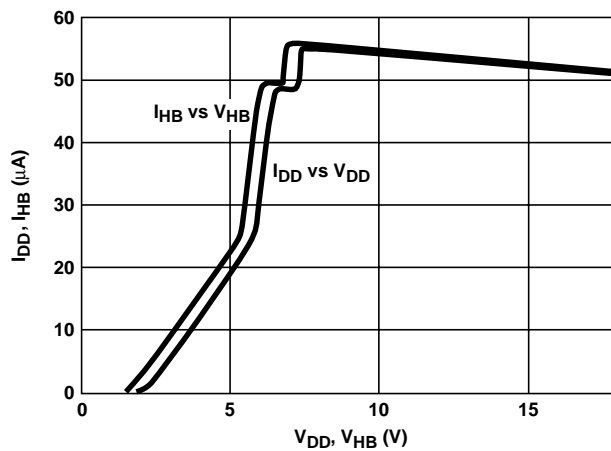
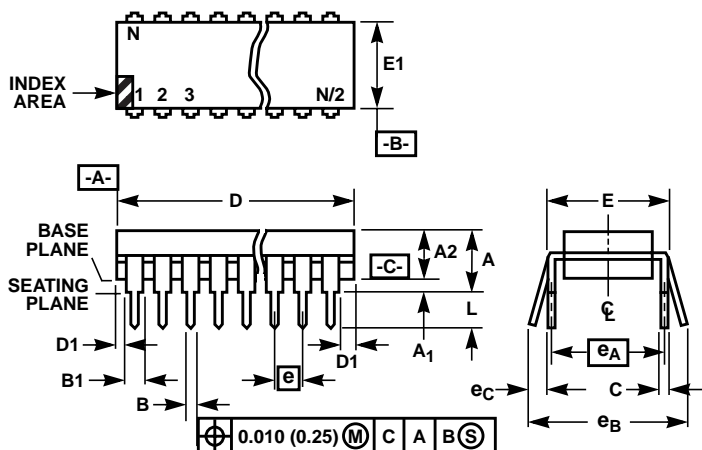

FIGURE 15. BIAS CURRENT vs VOLTAGE

Dual-In-Line Plastic Packages (PDIP)



NOTES:

- Controlling Dimensions: INCH. In case of conflict between English and Metric dimensions, the inch dimensions control.
- Dimensioning and tolerancing per ANSI Y14.5M-1982.
- Symbols are defined in the "MO Series Symbol List" in Section 2.2 of Publication No. 95.
- Dimensions A, A1 and L are measured with the package seated in JEDEC seating plane gauge GS-3.
- D, D1, and E1 dimensions do not include mold flash or protrusions. Mold flash or protrusions shall not exceed 0.010 inch (0.25mm).
- E and e_A are measured with the leads constrained to be perpendicular to datum $-C-$.
- e_B and e_C are measured at the lead tips with the leads unconstrained. e_C must be zero or greater.
- B1 maximum dimensions do not include dambar protrusions. Dambar protrusions shall not exceed 0.010 inch (0.25mm).
- N is the maximum number of terminal positions.
- Corner leads (1, N, N/2 and N/2 + 1) for E8.3, E16.3, E18.3, E28.3, E42.6 will have a B1 dimension of 0.030 - 0.045 inch (0.76 - 1.14mm).

E8.3 (JEDEC MS-001-BA ISSUE D)
8 LEAD DUAL-IN-LINE PLASTIC PACKAGE

SYMBOL	INCHES		MILLIMETERS		NOTES
	MIN	MAX	MIN	MAX	
A	-	0.210	-	5.33	4
A1	0.015	-	0.39	-	4
A2	0.115	0.195	2.93	4.95	-
B	0.014	0.022	0.356	0.558	-
B1	0.045	0.070	1.15	1.77	8, 10
C	0.008	0.014	0.204	0.355	-
D	0.355	0.400	9.01	10.16	5
D1	0.005	-	0.13	-	5
E	0.300	0.325	7.62	8.25	6
E1	0.240	0.280	6.10	7.11	5
e	0.100 BSC		2.54 BSC		-
e_A	0.300 BSC		7.62 BSC		6
e_B	-	0.430	-	10.92	7
L	0.115	0.150	2.93	3.81	4
N	8		8		9

Rev. 0 12/93

Small Outline Plastic Packages (SOIC)

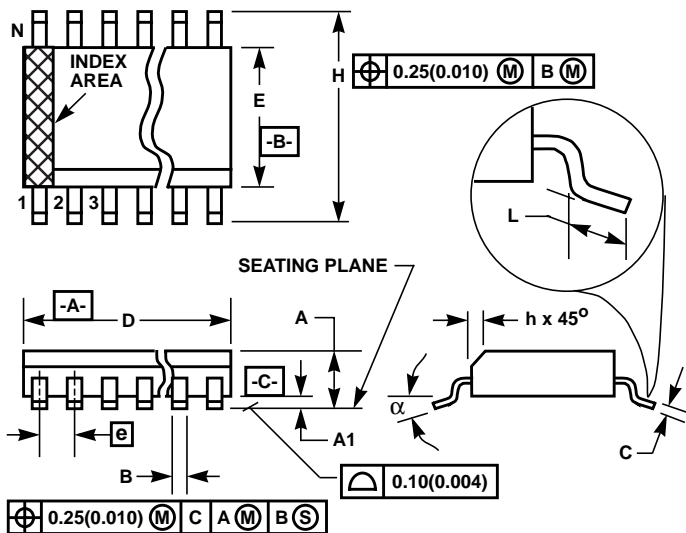

**M8.15 (JEDEC MS-012-AA ISSUE C)
8 LEAD NARROW BODY SMALL OUTLINE PLASTIC PACKAGE**

SYMBOL	INCHES		MILLIMETERS		NOTES
	MIN	MAX	MIN	MAX	
A	0.0532	0.0688	1.35	1.75	-
A1	0.0040	0.0098	0.10	0.25	-
B	0.013	0.020	0.33	0.51	9
C	0.0075	0.0098	0.19	0.25	-
D	0.1890	0.1968	4.80	5.00	3
E	0.1497	0.1574	3.80	4.00	4
e	0.050 BSC		1.27 BSC		-
H	0.2284	0.2440	5.80	6.20	-
h	0.0099	0.0196	0.25	0.50	5
L	0.016	0.050	0.40	1.27	6
N	8		8		7
α	0°	8°	0°	8°	-

NOTES:

1. Symbols are defined in the "MO Series Symbol List" in Section 2.2 of Publication Number 95.
2. Dimensioning and tolerancing per ANSI Y14.5M-1982.
3. Dimension "D" does not include mold flash, protrusions or gate burrs. Mold flash, protrusion and gate burrs shall not exceed 0.15mm (0.006 inch) per side.
4. Dimension "E" does not include interlead flash or protrusions. Interlead flash and protrusions shall not exceed 0.25mm (0.010 inch) per side.
5. The chamfer on the body is optional. If it is not present, a visual index feature must be located within the crosshatched area.
6. "L" is the length of terminal for soldering to a substrate.
7. "N" is the number of terminal positions.
8. Terminal numbers are shown for reference only.
9. The lead width "B", as measured 0.36mm (0.014 inch) or greater above the seating plane, shall not exceed a maximum value of 0.61mm (0.024 inch).
10. Controlling dimension: MILLIMETER. Converted inch dimensions are not necessarily exact.

Rev. 0 12/93

All Intersil semiconductor products are manufactured, assembled and tested under **ISO9000** quality systems certification.

Intersil semiconductor products are sold by description only. Intersil Corporation reserves the right to make changes in circuit design and/or specifications at any time without notice. Accordingly, the reader is cautioned to verify that data sheets are current before placing orders. Information furnished by Intersil is believed to be accurate and reliable. However, no responsibility is assumed by Intersil or its subsidiaries for its use; nor for any infringements of patents or other rights of third parties which may result from its use. No license is granted by implication or otherwise under any patent or patent rights of Intersil or its subsidiaries.

For information regarding Intersil Corporation and its products, see web site <http://www.intersil.com>

Sales Office Headquarters

NORTH AMERICA

Intersil Corporation
P. O. Box 883, Mail Stop 53-204
Melbourne, FL 32902
TEL: (407) 724-7000
FAX: (407) 724-7240

EUROPE

Intersil SA
Mercure Center
100, Rue de la Fusee
1130 Brussels, Belgium
TEL: (32) 2.724.2111
FAX: (32) 2.724.22.05

ASIA

Intersil (Taiwan) Ltd.
7F-6, No. 101 Fu Hsing North Road
Taipei, Taiwan
Republic of China
TEL: (886) 2 2716 9310
FAX: (886) 2 2715 3029