

DATA SHEET

UBA2032 Full bridge driver IC

Preliminary specification

2002 Oct 07

Full bridge driver IC**UBA2032****FEATURES**

- Full bridge driver circuit
- Integrated bootstrap diodes
- Integrated high voltage level shift function
- High voltage input for the internal supply voltage
- 550 V maximum bridge voltage
- Bridge disable function
- Input for start-up delay
- Adjustable oscillator frequency
- Predefined bridge position during start-up
- Adaptive non-overlap.

APPLICATIONS

- The UBA2032 can drive (via the MOSFETs) any kind of load in a full bridge configuration
- The circuit is especially designed as a commutator for High Intensity Discharge (HID) lamps.

GENERAL DESCRIPTION

The UBA2032 is a high voltage monolithic integrated circuit made in the EZ-HV SOI process. The circuit is designed for driving the MOSFETs in a full bridge configuration. In addition, it features a disable function, an internal adjustable oscillator and an external drive function with a high-voltage level shifter for driving the bridge. To guarantee an accurate 50% duty factor, the oscillator signal can be passed through a divider before being fed to the output drivers.

ORDERING INFORMATION

TYPE NUMBER	PACKAGE		
	NAME	DESCRIPTION	VERSION
UBA2032T	SO24	plastic small outline package; 24 leads; body width 7.5 mm	SOT137-1
UBA2032TS	SSOP28	plastic shrink small outline package; 28 leads; body width 5.3 mm	SOT341-1

Full bridge driver IC

UBA2032

BLOCK DIAGRAM

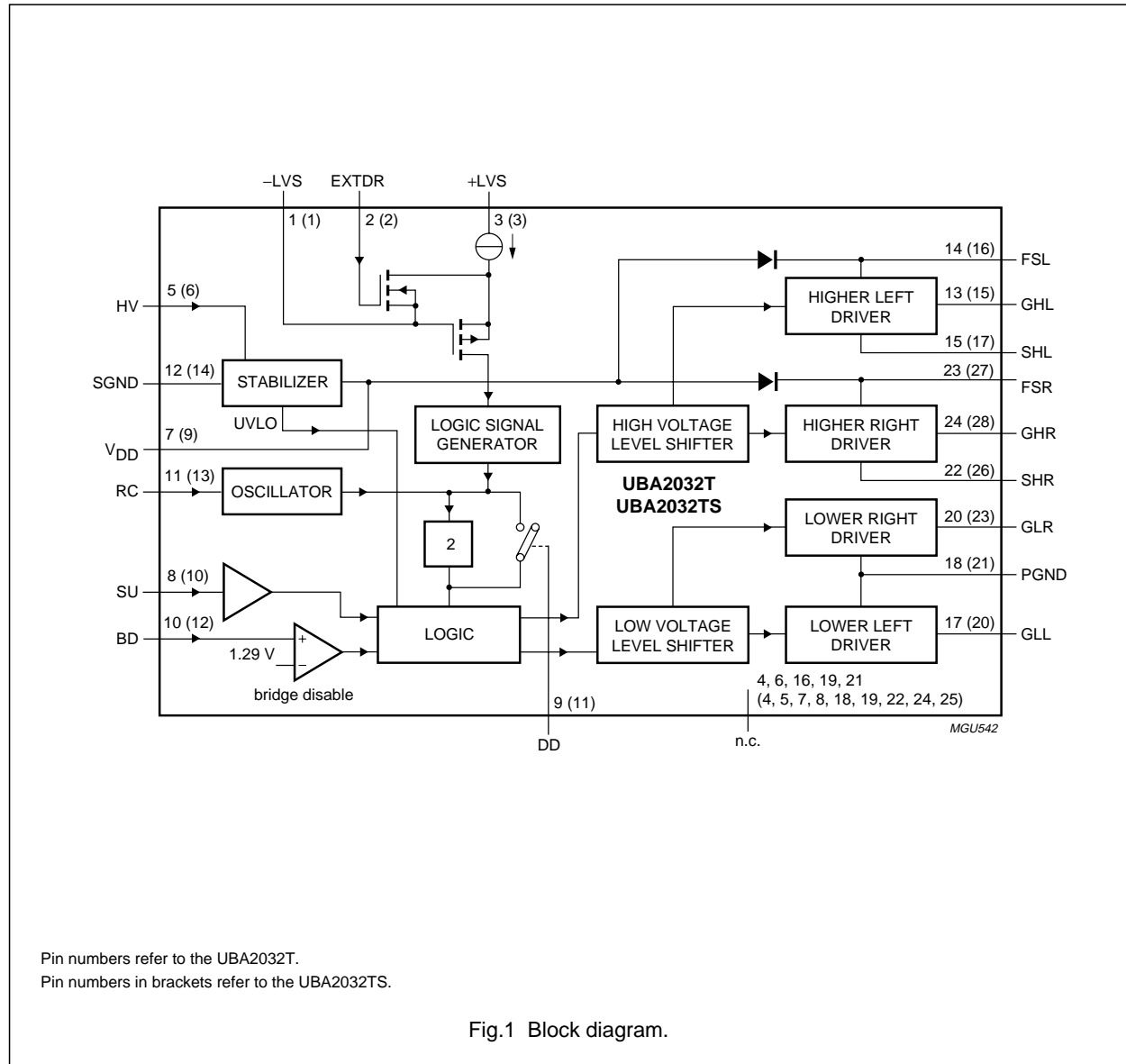

Full bridge driver IC

UBA2032

PINNING

SYMBOL	PIN		DESCRIPTION
	UBA2032T	UBA2032TS	
-LVS	1	1	negative supply voltage (for logic input)
EXTDR	2	2	oscillator signal input
+LVS	3	3	positive supply voltage (for logic input)
n.c.	4	4	not connected
n.c.	–	5	not connected
HV	5	6	high voltage supply input
n.c.	6	7	not connected
n.c.	–	8	not connected
V _{DD}	7	9	internal low voltage supply
SU	8	10	input signal for start-up delay
DD	9	11	divider disable input
BD	10	12	bridge disable control input
RC	11	13	RC input for internal oscillator
SGND	12	14	signal ground
GHL	13	15	gate of higher left MOSFET
FSL	14	16	floating supply voltage left
SHL	15	17	source of higher left MOSFET
n.c.	16	18	not connected
n.c.	–	19	not connected
GLL	17	20	gate of lower left MOSFET
PGND	18	21	power ground
n.c.	19	22	not connected
GLR	20	23	gate of lower right MOSFET
n.c.	21	24	not connected
n.c.	–	25	not connected
SHR	22	26	source of higher right MOSFET
FSR	23	27	floating supply voltage right
GHR	24	28	gate of higher right MOSFET

Full bridge driver IC

UBA2032

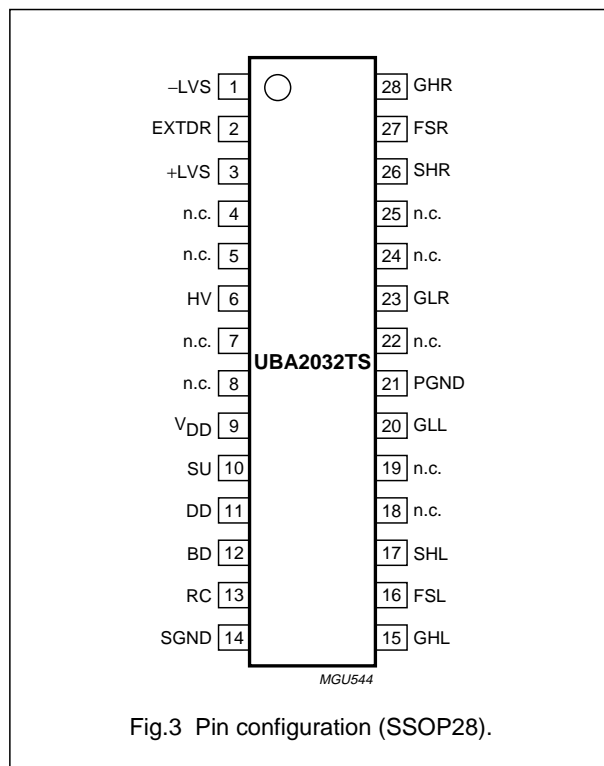
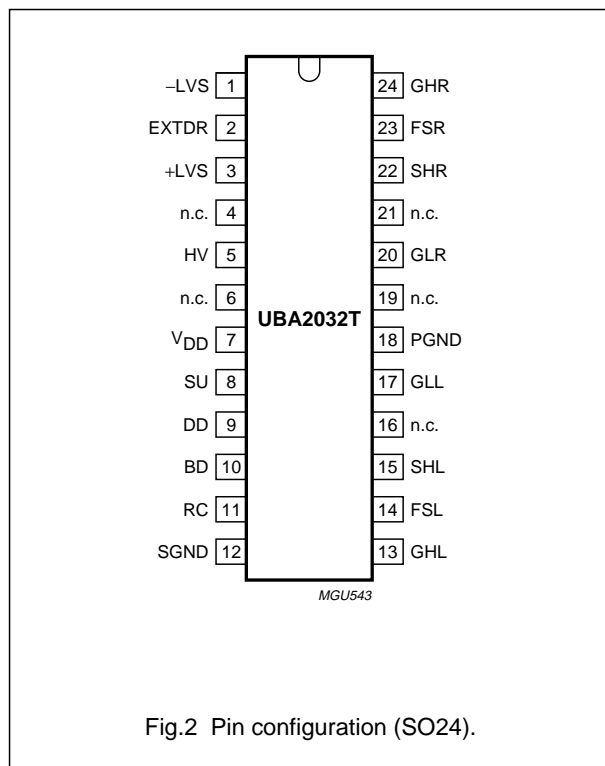

FUNCTIONAL DESCRIPTION

Supply voltage

The UBA2032 is powered by a supply voltage applied to pin HV, for instance the supply voltage of the full bridge. The IC generates its own low supply voltage for the internal circuitry. Therefore an additional low voltage supply is not required. A capacitor has to be connected to pin V_{DD} to obtain a ripple-free internal supply voltage. The circuit can also be powered by a low voltage supply directly applied to pin V_{DD} . In this case pin HV should be connected to pin V_{DD} or SGND.

Start-up

With an increasing supply voltage the IC enters the start-up state; the higher power transistors are kept off and the lower power transistors are switched on. During the start-up state the bootstrap capacitors are charged and the bridge output current is zero. The start-up state is defined until $V_{DD} = V_{DD(UVLO)}$, where UVLO stands for Under Voltage Lock-out. The state of the outputs during the start-up phase is overruled by the bridge disable function.

Release of the power drive

At the moment the supply voltage on pin V_{DD} or HV exceeds the level of release power drive the output voltage of the bridge depends on the control signal on pin EXTDR see Table 1. The bridge position after start-up, disable, or delayed start-up (via pin SU) depends on the status of the pins DD and EXTDR. If pin DD = LOW (divider enabled) the bridge will start in the pre-defined position pin GLR and pin GHL = HIGH and pin GLL and pin GHR = LOW. If pin DD = HIGH (divider disabled) the bridge position will depend on the status of pin EXTDR.

If the supply voltage on pin V_{DD} or HV decreases and drops below the reset level of power drive the IC enters the start-up state again.

Oscillation

At the point where the supply voltage on pin HV crosses the level of release power drive, the bridge begins commutating between the following two defined states:

- Higher left and lower right MOSFETs on, higher right and lower left MOSFETs off
- Higher left and lower right MOSFETs off, higher right and lower left MOSFETs on.

Full bridge driver IC

UBA2032

The oscillation can take place in three different modes:

- Internal oscillator mode.

In this mode the bridge commutating frequency is determined by the values of an external resistor (R_{osc}) and capacitor (C_{osc}). In this mode pin EXTDR must be connected to pin +LVS. To realize an accurate 50% duty factor, the internal divider should be used. The internal divider is enabled by connecting pin DD to SGND. Due to the presence of the divider the bridge frequency is half the oscillator frequency. The commutation of the bridge will take place at the falling edge of the signal on pin RC. To minimize the current consumption pins +LVS, -LVS and EXTDR can be connected together to either pin SGND or V_{DD} . In this way the current source in the logic voltage supply circuit is shut off.

- External oscillator mode without the internal divider.

In the external oscillator mode the external source is connected to pin EXTDR and pin RC is short-circuited to pin SGND to disable the internal oscillator. If the internal divider is disabled ($DD = V_{DD}$) the duty factor of the bridge output signal is determined by the external oscillator signal and the bridge frequency equals the external oscillator frequency.

- External oscillator mode with the internal divider.

The external oscillator mode can also be used with the internal divider function enabled ($RC = DD = SGND$). Due to the presence of the divider the bridge frequency is half the external oscillator frequency. The commutation of the bridge is triggered by the falling edge of the EXTDR signal with respect to V_{-LVS} .

If the supply voltage on pin V_{DD} or HV drops below the reset level of power drive, the UBA2032 re-enters the start-up phase. The design equation for the bridge

$$\text{oscillator frequency is: } f_{\text{bridge}} = \frac{1}{(k_{\text{osc}} \times R_{\text{osc}} \times C_{\text{osc}})}$$

Non-overlap time

The non-overlap time is the time between turning off the conducting pair of MOSFETs and turning on the next pair. The non-overlap time is realized by means of an adaptive non-overlap circuit. With an adaptive non-overlap, the application determines the duration of the non-overlap and makes the non-overlap time optimal for each frequency. The non-overlap time is determined by the duration of the falling slope of the relevant half bridge voltage (see Fig.4). The occurrence of a slope is sensed internally. The minimum non-overlap time is internally fixed.

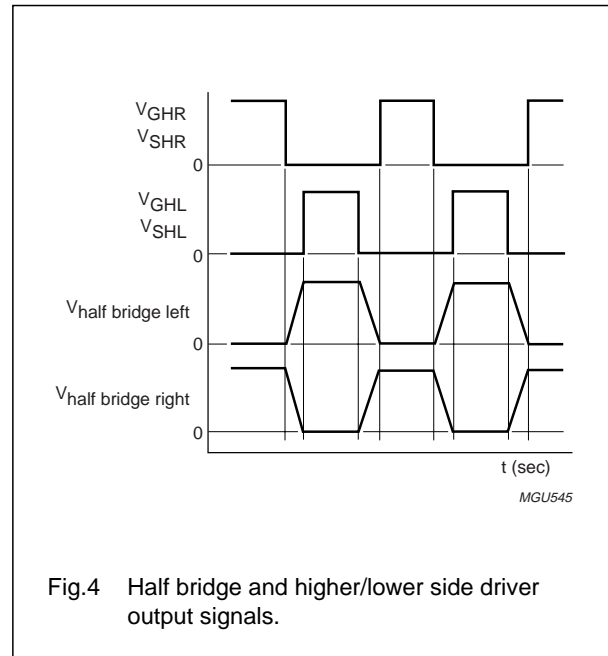

Fig.4 Half bridge and higher/lower side driver output signals.

Divider function

If pin $DD = SGND$ then the divider function is enabled/present. If the divider function is present there is no direct relation between the position of the bridge output and the status of pin EXTDR.

Start-up delay

Normally, the circuit starts oscillating as soon as pin V_{DD} or HV reaches the level of release power drive. At this moment the gate drive voltage is equal to the voltage on pin V_{DD} for the low side transistors and $V_{DD} - 0.6 \text{ V}$ for the high side transistors. If this voltage is too low for sufficient drive of the MOSFETs the release of the power drive can be delayed via pin SU. A simple RC filter (R between pins V_{DD} and SU; C between pins SU and SGND) can be used to make a delay, or a control signal from a processor can be used.

Bridge disable

The bridge disable function can be used to switch off all the MOSFETs as soon as the voltage on pin BD exceeds the bridge disable voltage (1.29 V). The bridge disable function overrules all the other states.

Full bridge driver IC

UBA2032

Table 1 Logic table; note 1

DEVICE STATUS	INPUTS ⁽²⁾				OUTPUTS ⁽³⁾			
	BD	SU	DD	EXTDR	GHL	GHR	GLL	GLR
Start-up state	HIGH	X	X	X	LOW	LOW	LOW	LOW
	LOW	X	X	X	LOW	LOW	HIGH	HIGH
Oscillation state	HIGH	X	X	X	LOW	LOW	LOW	LOW
	LOW	LOW	X	X	LOW	LOW	HIGH	HIGH
	LOW	HIGH	HIGH	HIGH	LOW	HIGH	HIGH	LOW
				LOW	HIGH	LOW	LOW	HIGH
	LOW	HIGH	LOW ⁽⁴⁾	LOW	HIGH	LOW	LOW	HIGH
				LOW-to-HIGH	HIGH	LOW	LOW	HIGH
				HIGH	HIGH	LOW	LOW	HIGH
				HIGH-to-LOW ⁽⁵⁾	LOW	HIGH	HIGH	LOW

Notes

1. X = don't care.
2. BD, SU and DD logic levels are with respect to SGND;
EXTDR logic levels are with respect to V_{-LVS} .
3. GHL logic levels are with respect to SHL;
GHR logic levels are with respect to SHR;
GLL and GLR logic levels are with respect to PGND.
4. If pin DD = LOW the bridge enters the state (oscillation state and pin BD = LOW and pin SU = HIGH) in the pre-defined position pin GHL and pin GLR = HIGH and pin GLL and pin GHR = LOW.
5. Only if the level of pin EXTDR changes from HIGH-to-LOW, the level of outputs GHL, GHR, GLL and GLR changes from LOW-to-HIGH or from HIGH-to-LOW.

Full bridge driver IC

UBA2032

LIMITING VALUES

In accordance with the Absolute Maximum Rating System (IEC 60134); all voltages are measured with respect to SGND; positive currents flow into the IC.

SYMBOL	PARAMETER	CONDITIONS	MIN.	MAX.	UNIT
V _{DD}	supply voltage (low voltage)	DC value	0	14	V
		transient at $t < 0.1 \mu\text{s}$	0	17	V
V _{HV}	supply voltage (high voltage)		0	550	V
V _{FSL}	floating supply voltage left	V _{SHL} = V _{SHR} = 550 V	0	564	V
		V _{SHL} = V _{SHR} = 0 V	0	14	V
V _{FSR}	floating supply voltage right	V _{SHL} = V _{SHR} = 550 V	0	564	V
		V _{SHL} = V _{SHR} = 0 V	0	14	V
V _{SHL}	source voltage for higher left MOSFETs	with respect to PGND and SGND	-3	+550	V
		with respect to SGND; $t < 1 \mu\text{s}$	-14	-	V
V _{SHR}	source voltage for higher right MOSFETs	with respect to PGND and SGND	-3	+550	V
		with respect to SGND; $t < 1 \mu\text{s}$	-14	-	V
V _{PGND}	power ground voltage	with respect to SGND	0	5	V
V _{-LVS}	negative supply voltage for logic input	$t < 1 \text{ s}$	0	464	V
V _{+LVS}	positive supply voltage for logic input	V _{HV} = 450 V; $t < 1 \text{ s}$	0	464	V
		V _{HV} = 0 V; DC value	0	14	V
		V _{HV} = 0 V; transient at $t < 0.1 \mu\text{s}$	0	17	V
V _{i(EXTDR)}	input voltage from external oscillator on pin EXTDR	with respect to V _{-LVS}	0	V _{+LVS}	V
V _{i(RC)}	input voltage on pin RC	DC value	0	V _{DD}	V
		transient at $t < 0.1 \mu\text{s}$	0	17	V
V _{i(SU)}	input voltage on pin SU	DC value	0	V _{DD}	V
		transient at $t < 0.1 \mu\text{s}$	0	17	V
V _{i(BD)}	input voltage on pin BD	DC value	0	V _{DD}	V
		transient at $t < 0.1 \mu\text{s}$	0	17	V
V _{i(DD)}	input voltage on pin DD	DC value	0	V _{DD}	V
		transient at $t < 0.1 \mu\text{s}$	0	17	V
SR	slew rate at output pins	repetitive	0	4	V/ns
T _j	junction temperature		-40	+150	°C
T _{amb}	ambient temperature		-40	+150	°C
T _{stg}	storage temperature		-55	+150	°C
V _{esd}	electrostatic discharge voltage on pins HV, +LVS, -LVS, EXTDR, FSL, GHL, SHL, SHR, GHR and FSR	note 1	-	900	V

Note

1. In accordance with the Human Body Model (HBM): equivalent to discharging a 100 pF capacitor through a 1.5 kΩ series resistor.

Full bridge driver IC

UBA2032

THERMAL CHARACTERISTICS

SYMBOL	PARAMETER	CONDITIONS	VALUE	UNIT
$R_{th(j-a)}$	thermal resistance from junction to ambient	in free air		
	UBA2032T		80	K/W
	UBA2032TS		100	K/W

QUALITY SPECIFICATION

In accordance with "SNW-FQ-611D".

CHARACTERISTICS

$T_j = 25\text{ }^\circ\text{C}$; all voltages are measured with respect to SGND; positive currents flow into the IC; unless otherwise specified.

SYMBOL	PARAMETER	CONDITIONS	MIN.	TYP.	MAX.	UNIT
High voltage						
I_{HV}	high voltage supply current	$t < 0.5\text{ s}$ and $V_{HV} = 550\text{ V}$	0	–	30	μA
I_{FSL}, I_{FSR}	high voltage floating supply current	$t < 0.5\text{ s}$ and $V_{FSL} = V_{FSR} = 564\text{ V}$	0	–	30	μA
$I_{HV(drive)}$	supply current on pins EXTDR and +LVS	$t < 0.5\text{ s}$ and $V_{HV(drive)} = 464\text{ V}$	0	–	30	μA
	supply current on pin –LVS	$t < 0.5\text{ s}$ and $V_{HV(drive)} = 450\text{ V}$	0	–	30	μA
Start-up; powered via pin HV						
$I_{i(HV)}$	HV input current	$V_{HV} = 11\text{ V}$; note 1	–	0.5	1.0	mA
$V_{HV(rel)}$	level of release power drive voltage		11	12.5	14	V
$V_{HV(UVLO)}$	reset level of power drive voltage		8.5	10	11.5	V
$V_{HV(hys)}$	HV hysteresis voltage		2.0	2.5	3.0	V
V_{DD}	internal supply voltage	$V_{HV} = 20\text{ V}$	10.5	11.5	13.5	V
Start-up; powered via pin V_{DD}						
$I_{i(DD)}$	V_{DD} input current	$V_{DD} = 8.25\text{ V}$; note 2	–	0.5	1.0	mA
$V_{DD(rel)}$	level of release power drive voltage		8.25	9.0	9.75	V
$V_{DD(UVLO)}$	reset level of power drive voltage		5.75	6.5	7.25	V
$V_{DD(hys)}$	hysteresis voltage		2.0	2.5	3.0	V

Full bridge driver IC

UBA2032

SYMBOL	PARAMETER	CONDITIONS	MIN.	TYP.	MAX.	UNIT
Output stage						
$R_{on(H)}$	higher MOSFETs on resistance	$V_{FSR} = V_{FSL} = 12\text{ V}$; with respect to SHR and SHL; $I_{source} = 50\text{ mA}$	15	21	26	Ω
$R_{off(H)}$	higher MOSFETs off resistance	$V_{FSR} = V_{FSL} = 12\text{ V}$; with respect to SHR and SHL; $I_{sink} = 50\text{ mA}$	9	14	18	Ω
$R_{on(L)}$	lower MOSFETs on resistance	$V_{DD} = 12\text{ V}$; $I_{source} = 50\text{ mA}$	15	21	26	Ω
$R_{off(L)}$	lower MOSFETs off resistance	$V_{DD} = 12\text{ V}$; $I_{sink} = 50\text{ mA}$	9	14	18	Ω
$I_{o(source)}$	output source current	$V_{DD} = V_{FSL} = V_{FSR} = 12\text{ V}$; $V_{GHR} = V_{GHL} = V_{GLR} = V_{GLL} = 0\text{ V}$	130	180	–	mA
$I_{o(sink)}$	output sink current	$V_{DD} = V_{FSL} = V_{FSR} = 12\text{ V}$; $V_{GHR} = V_{GHL} = V_{GLR} = V_{GLL} = 12\text{ V}$	150	200	–	mA
V_{diode}	bootstrap diode voltage drop	$I_{diode} = 1\text{ mA}$	0.8	1.0	1.2	V
T_{slope}	minimum $\Delta V/\Delta T$ for adaptive non-overlap	absolute values	5	15	25	V/ μs
$t_{no(min)}$	minimum non-overlap time		600	900	1300	ns
V_{FSL}	HS lockout voltage left		3.0	4.0	5.0	V
V_{FSR}	HS lockout voltage right		3.0	4.0	5.0	V
I_{FSL}	FS supply current left	$V_{FSL} = 12\text{ V}$	2	4	6	μA
I_{FSR}	FS supply current right	$V_{FSR} = 12\text{ V}$	2	4	6	μA
DD input						
V_{IH}	HIGH-level input voltage	$V_{DD} = 12\text{ V}$	6	–	–	V
V_{IL}	LOW-level input voltage		–	–	3	V
$I_{i(DD)}$	input current into pin DD		–	–	1	μA
SU input						
V_{IH}	HIGH-level input voltage	$V_{DD} = 12\text{ V}$	4	–	–	V
V_{IL}	LOW-level input voltage		–	–	2	V
$I_{i(SU)}$	input current into pin SU		–	–	1	μA
External drive input						
V_{IH}	HIGH-level input voltage	with respect to V_{-LVS}	4.0	–	–	V
V_{IL}	LOW-level input voltage	with respect to V_{-LVS}	–	–	1.0	V
$I_{i(EXTDR)}$	input current into pin EXTDR		–	–	1	μA
f_{bridge}	bridge frequency	note 3	–	–	200	kHz
Low voltage logic supply						
I_{+LVS}	low voltage supply current	$V_{+LVS} = V_{EXTDR} = 5.75\text{ to }14\text{ V}$ with respect to V_{-LVS}	–	250	500	μA
V_{+LVS}	low voltage supply voltage	with respect to V_{-LVS}	5.75	–	14	V
Bridge disable circuit						
$V_{ref(dis)}$	disable reference voltage		1.23	1.29	1.35	V
$I_{i(BD)}$	disable input current		–	–	1	μA

Full bridge driver IC

UBA2032

SYMBOL	PARAMETER	CONDITIONS	MIN.	TYP.	MAX.	UNIT
Internal oscillator						
f_{bridge}	bridge oscillating frequency	note 3	–	–	100	kHz
$\Delta f_{\text{osc}(T)}$	oscillator frequency variation with respect to temperature	$f_{\text{bridge}} = 250 \text{ Hz}$ and $T_{\text{amb}} = -40 \text{ to } +150 \text{ }^\circ\text{C}$	–10	0	+10	%
$\Delta f_{\text{osc}(V_{\text{DD}})}$	oscillator frequency variation with respect to V_{DD}	$f_{\text{bridge}} = 250 \text{ Hz}$ and $V_{\text{DD}} = 7.25 \text{ to } 14 \text{ V}$	–10	0	+10	%
k_{H}	high level trip point	$V_{\text{RC}(\text{high})} = k_{\text{H}} \times V_{\text{DD}}$	0.38	0.4	0.42	
k_{L}	low level trip point	$V_{\text{RC}(\text{low})} = k_{\text{L}} \times V_{\text{DD}}$	–	0.01	–	
k_{osc}	oscillator constant	$f_{\text{bridge}} = 250 \text{ Hz}$	0.94	1.02	1.10	
R_{ext}	external resistor to V_{DD}		100	–	–	k Ω

Notes

1. The current is specified without commutation of the bridge. The current into pin HV is limited by a thermal protection circuit. The current is limited to 11 mA at $T_j = 150 \text{ }^\circ\text{C}$.
2. The current is specified without commutation of the bridge and pin HV is connected to V_{DD} .
3. The minimum frequency is mainly determined by the value of the bootstrap capacitors.

Full bridge driver IC

UBA2032

APPLICATION INFORMATION

Basic application

A basic full bridge configuration with an HID lamp is shown in Fig.5. The bridge disable, the start-up delay and the external drive functions are not used in this application. The pins -LVS, +LVS, EXTDR and BD are short-circuited to SGND. The internal oscillator is used and to realise a 50% duty cycle the internal divider function has to be used by connecting pin DD to SGND. The IC is powered by the high voltage supply. Because the internal oscillator is

used, the bridge commutating frequency is determined by the values of R_{osc} and C_{osc} . The bridge starts oscillating when the HV supply voltage exceeds the level of release power drive (typically 12.5 V on pin HV). If the supply voltage on pin HV drops below the reset level of power drive (typically 10 V on pin HV), the UBA2032 enters the start-up state.

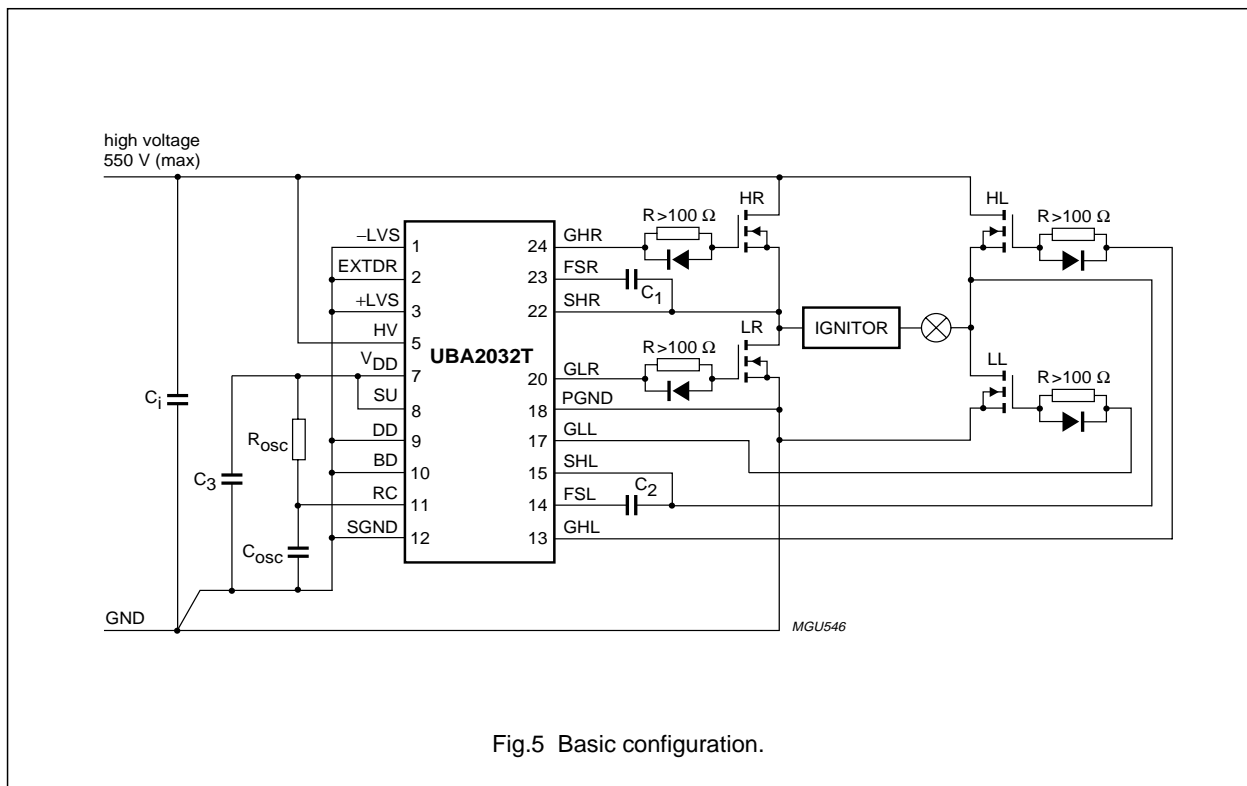

Full bridge driver IC

UBA2032

Application with external control

Figure 6 shows an application containing a system ground-referenced control circuit. Pin +LVS can be connected to the same supply as the external oscillator control unit and pin -LVS is connected to SGND. Pin RC is

short-circuited to SGND. The bridge commutation frequency is determined by the external oscillator. The bridge disable input (pin BD) can be used to immediately turn off all four MOSFETs in the full bridge.

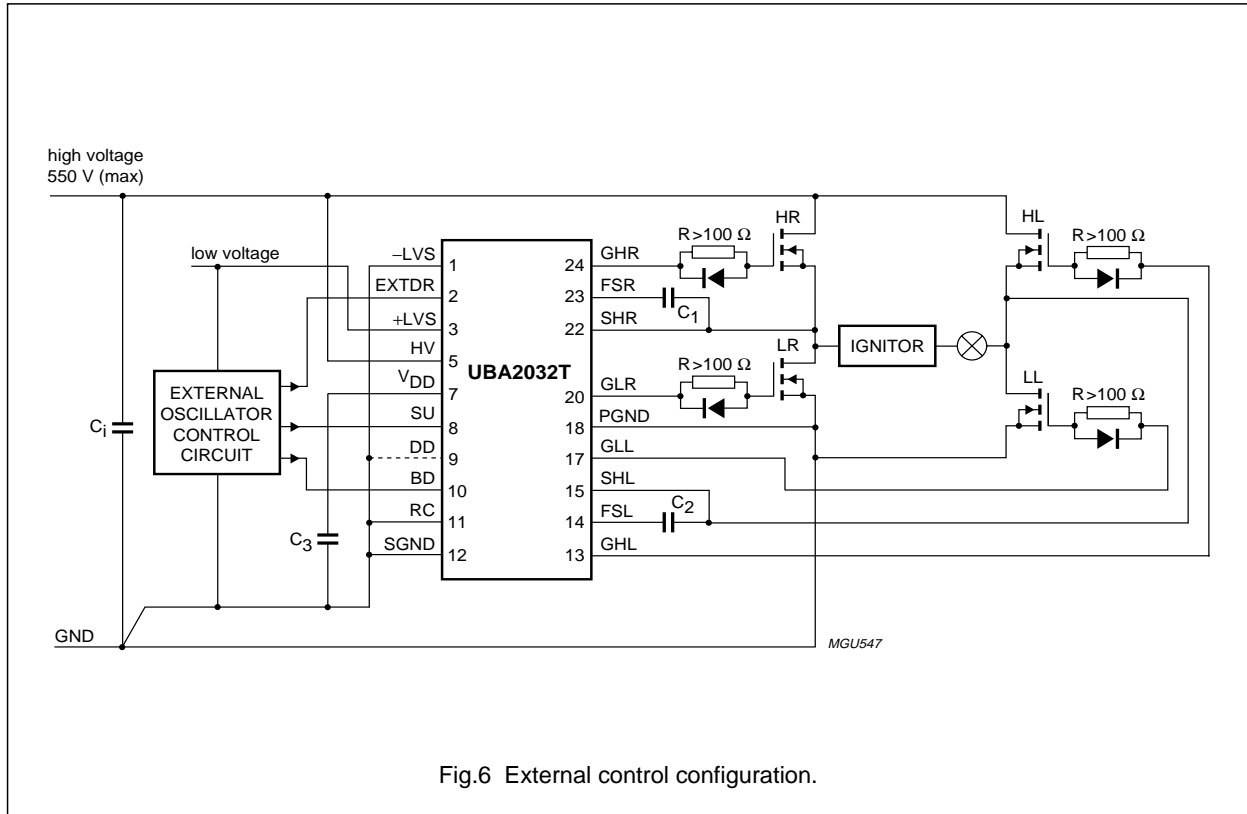

Fig.6 External control configuration.

Full bridge driver IC

UBA2032

Car headlight application

The life of an HID lamp depends of the rate of sodium migration through the quartz wall of the lamp. To minimize this, the lamp must operate negative with respect to the system ground. Figure 5 shows a full bridge with an HID lamp for a car headlight application, along with a control

circuit referenced to the system ground and with a bridge voltage operating at high negative voltages with respect to the system ground. Pin +LVS and HV can be connected to the same supply as the control unit. The output state of the bridge is related to the position of pin EXTDR. See also the timing diagram.

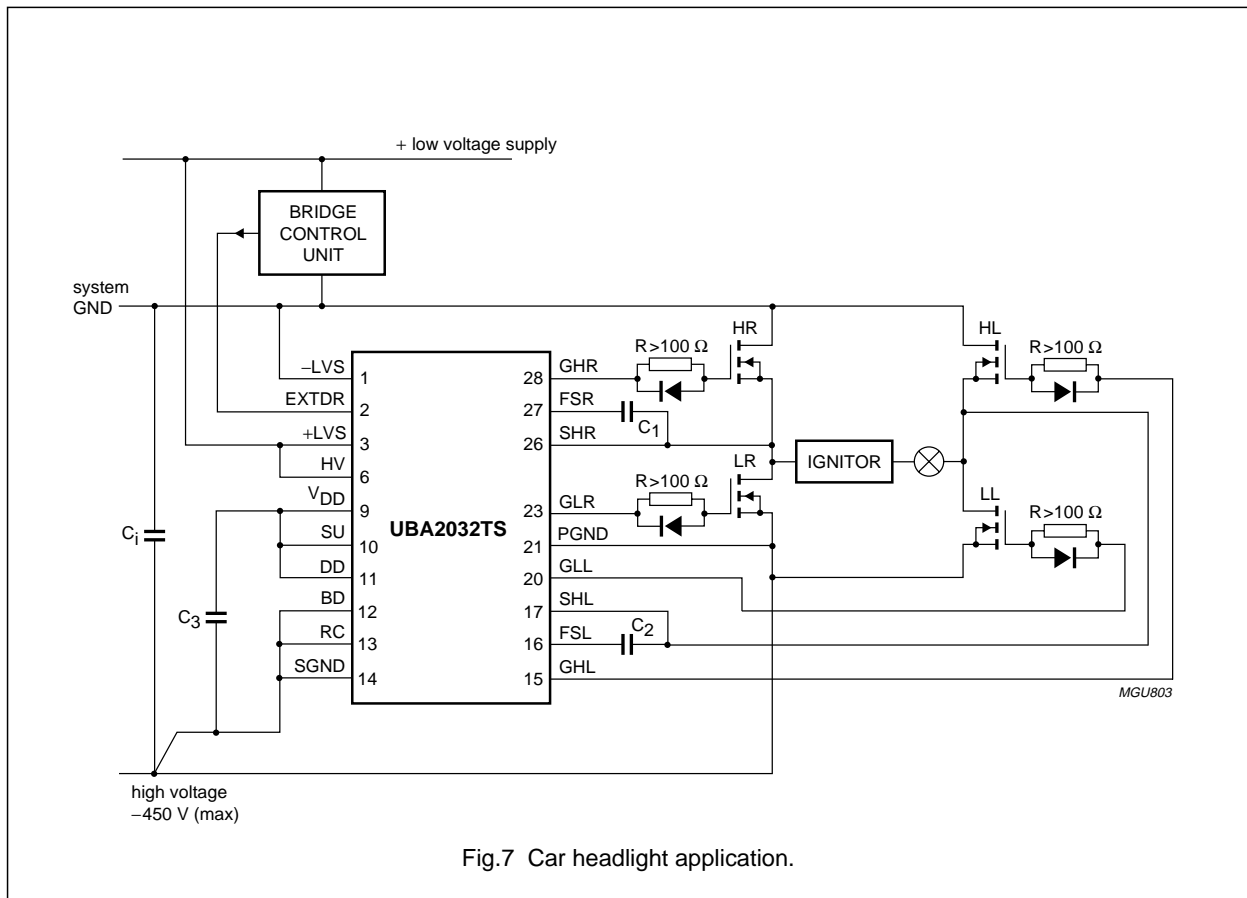

Fig.7 Car headlight application.

Full bridge driver IC

UBA2032

Additional application information

GATE RESISTORS

At ignition of an HID lamp, a large EMC spark occurs. This can result in a large voltage transient or oscillation at the gates of the full bridge MOSFETs (LL, LR, HR and HL). When these gates are directly coupled to the gate drivers (pins GHR, GLR, GHL and GLL), voltage overstress of the driver outputs may occur. Therefore it is advised to add a resistor with a minimum value of 100 Ω in series with each gate driver to isolate the gate driver outputs from the actual power MOSFETs gate.

GATE CHARGE AND SUPPLY CURRENT AT HIGH FREQUENCY USE

The total gate current needed to charge the gates of the power MOSFETs equals:

$$I_{\text{gate}} = 4 \times f_{\text{bridge}} \times Q_{\text{gate}}$$

Where:

I_{gate} = gate current

f_{bridge} = bridge frequency

Q_{gate} = gate charge.

This current is supplied via the internal low voltage supply (V_{DD}). Since this current is limited to 11 mA (see table "Characteristics", note 1), at higher frequencies and with MOSFETs having a relative high gate charge, this maximum V_{DD} supply current may not be sufficient anymore. As a result the internal low voltage supply (V_{DD}) and the gate drive voltage will drop resulting in an increase of the on resistance (R_{on}) of the full bridge MOSFETs. In this case an auxiliary low voltage supply is necessary.

Full bridge driver IC

UBA2032

PACKAGE OUTLINES

SO24: plastic small outline package; 24 leads; body width 7.5 mm

SOT137-1

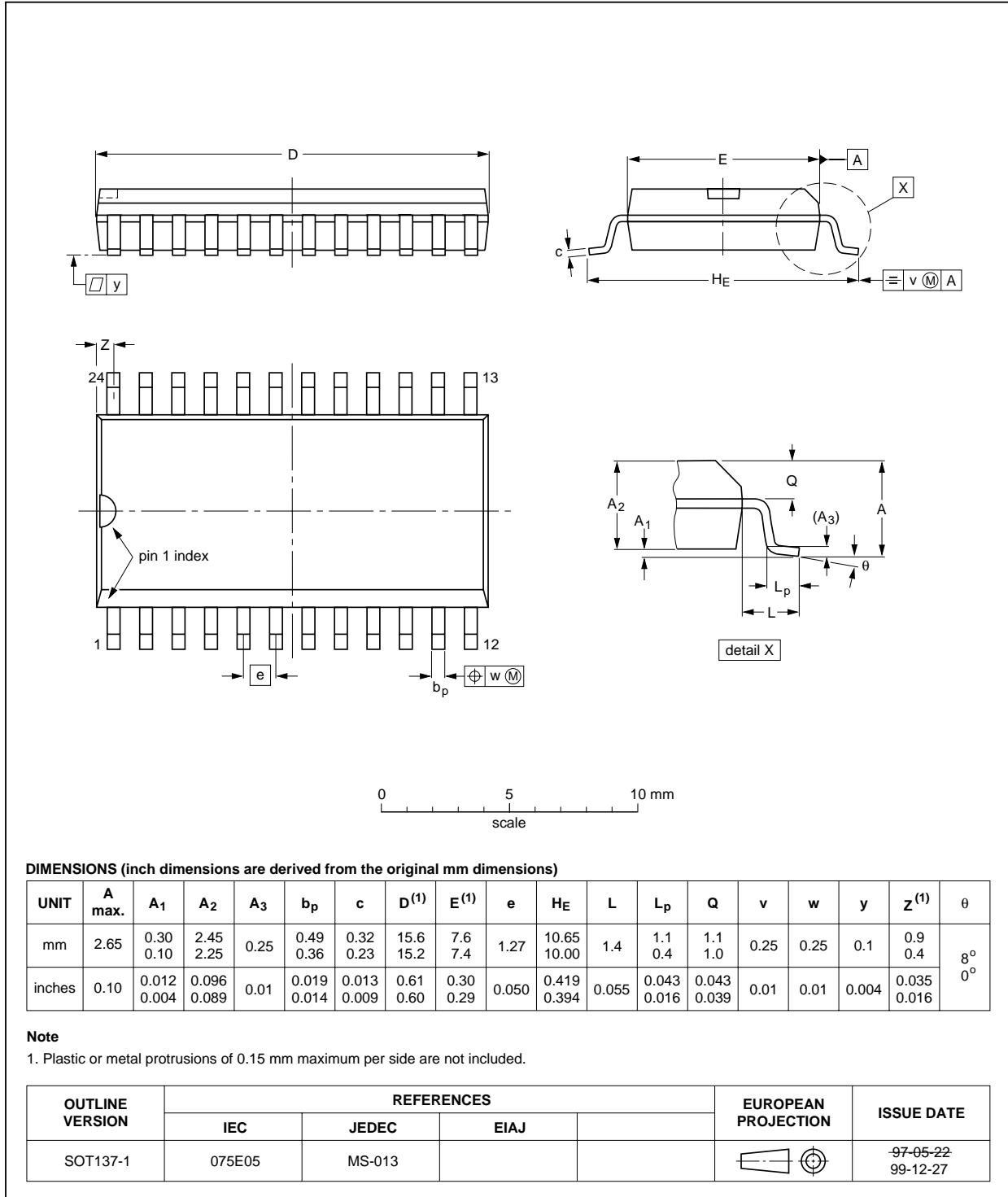

Full bridge driver IC

UBA2032

SSOP28: plastic shrink small outline package; 28 leads; body width 5.3 mm

SOT341-1

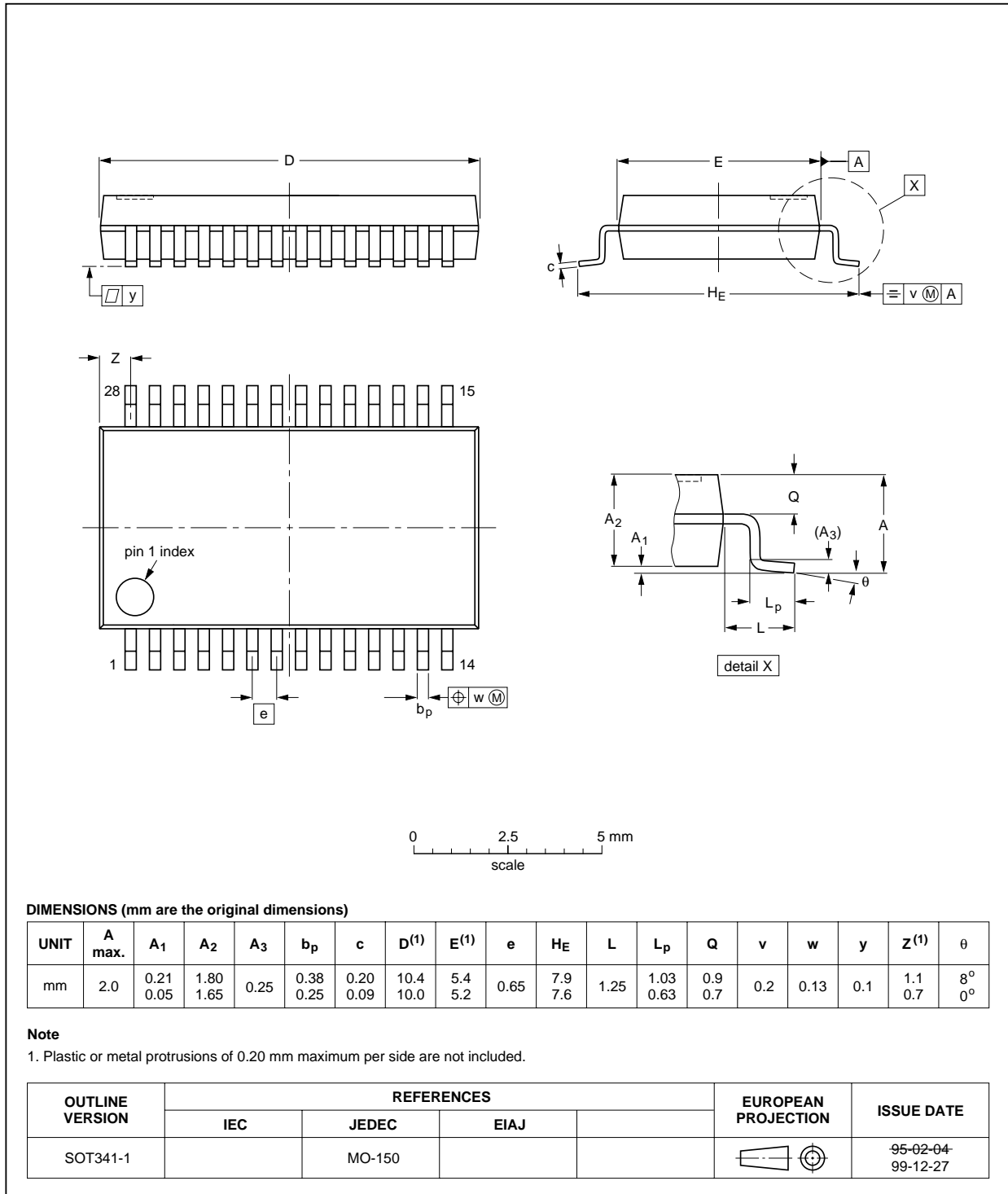

Full bridge driver IC

UBA2032

SOLDERING

Introduction to soldering surface mount packages

This text gives a very brief insight to a complex technology. A more in-depth account of soldering ICs can be found in our *"Data Handbook IC26; Integrated Circuit Packages"* (document order number 9398 652 90011).

There is no soldering method that is ideal for all surface mount IC packages. Wave soldering can still be used for certain surface mount ICs, but it is not suitable for fine pitch SMDs. In these situations reflow soldering is recommended.

Reflow soldering

Reflow soldering requires solder paste (a suspension of fine solder particles, flux and binding agent) to be applied to the printed-circuit board by screen printing, stencilling or pressure-syringe dispensing before package placement.

Several methods exist for reflowing; for example, convection or convection/infrared heating in a conveyor type oven. Throughput times (preheating, soldering and cooling) vary between 100 and 200 seconds depending on heating method.

Typical reflow peak temperatures range from 215 to 250 °C. The top-surface temperature of the packages should preferably be kept below 220 °C for thick/large packages, and below 235 °C for small/thin packages.

Wave soldering

Conventional single wave soldering is not recommended for surface mount devices (SMDs) or printed-circuit boards with a high component density, as solder bridging and non-wetting can present major problems.

To overcome these problems the double-wave soldering method was specifically developed.

If wave soldering is used the following conditions must be observed for optimal results:

- Use a double-wave soldering method comprising a turbulent wave with high upward pressure followed by a smooth laminar wave.
- For packages with leads on two sides and a pitch (e):
 - larger than or equal to 1.27 mm, the footprint longitudinal axis is **preferred** to be parallel to the transport direction of the printed-circuit board;
 - smaller than 1.27 mm, the footprint longitudinal axis **must** be parallel to the transport direction of the printed-circuit board.

The footprint must incorporate solder thieves at the downstream end.

- For packages with leads on four sides, the footprint must be placed at a 45° angle to the transport direction of the printed-circuit board. The footprint must incorporate solder thieves downstream and at the side corners.

During placement and before soldering, the package must be fixed with a droplet of adhesive. The adhesive can be applied by screen printing, pin transfer or syringe dispensing. The package can be soldered after the adhesive is cured.

Typical dwell time is 4 seconds at 250 °C.

A mildly-activated flux will eliminate the need for removal of corrosive residues in most applications.

Manual soldering

Fix the component by first soldering two diagonally-opposite end leads. Use a low voltage (24 V or less) soldering iron applied to the flat part of the lead. Contact time must be limited to 10 seconds at up to 300 °C.

When using a dedicated tool, all other leads can be soldered in one operation within 2 to 5 seconds between 270 and 320 °C.

Full bridge driver IC

UBA2032

Suitability of surface mount IC packages for wave and reflow soldering methods

PACKAGE	SOLDERING METHOD	
	WAVE	REFLOW ⁽¹⁾
BGA, HBGA, LFBGA, SQFP, TFBGA	not suitable	suitable
HBCC, HLQFP, HSQFP, HSOP, HTQFP, HTSSOP, HVQFN, SMS	not suitable ⁽²⁾	suitable
PLCC ⁽³⁾ , SO, SOJ	suitable	suitable
LQFP, QFP, TQFP	not recommended ⁽³⁾⁽⁴⁾	suitable
SSOP, TSSOP, VSO	not recommended ⁽⁵⁾	suitable

Notes

1. All surface mount (SMD) packages are moisture sensitive. Depending upon the moisture content, the maximum temperature (with respect to time) and body size of the package, there is a risk that internal or external package cracks may occur due to vaporization of the moisture in them (the so called popcorn effect). For details, refer to the Drypack information in the *"Data Handbook IC26; Integrated Circuit Packages; Section: Packing Methods"*.
2. These packages are not suitable for wave soldering. On versions with the heatsink on the bottom side, the solder cannot penetrate between the printed-circuit board and the heatsink. On versions with the heatsink on the top side, the solder might be deposited on the heatsink surface.
3. If wave soldering is considered, then the package must be placed at a 45° angle to the solder wave direction. The package footprint must incorporate solder thieves downstream and at the side corners.
4. Wave soldering is only suitable for LQFP, TQFP and QFP packages with a pitch (e) equal to or larger than 0.8 mm; it is definitely not suitable for packages with a pitch (e) equal to or smaller than 0.65 mm.
5. Wave soldering is only suitable for SSOP and TSSOP packages with a pitch (e) equal to or larger than 0.65 mm; it is definitely not suitable for packages with a pitch (e) equal to or smaller than 0.5 mm.

Full bridge driver IC

UBA2032

DATA SHEET STATUS

LEVEL	DATA SHEET STATUS ⁽¹⁾	PRODUCT STATUS ⁽²⁾⁽³⁾	DEFINITION
I	Objective data	Development	This data sheet contains data from the objective specification for product development. Philips Semiconductors reserves the right to change the specification in any manner without notice.
II	Preliminary data	Qualification	This data sheet contains data from the preliminary specification. Supplementary data will be published at a later date. Philips Semiconductors reserves the right to change the specification without notice, in order to improve the design and supply the best possible product.
III	Product data	Production	This data sheet contains data from the product specification. Philips Semiconductors reserves the right to make changes at any time in order to improve the design, manufacturing and supply. Relevant changes will be communicated via a Customer Product/Process Change Notification (CPCN).

Notes

1. Please consult the most recently issued data sheet before initiating or completing a design.
2. The product status of the device(s) described in this data sheet may have changed since this data sheet was published. The latest information is available on the Internet at URL <http://www.semiconductors.philips.com>.
3. For data sheets describing multiple type numbers, the highest-level product status determines the data sheet status.

DEFINITIONS

Short-form specification — The data in a short-form specification is extracted from a full data sheet with the same type number and title. For detailed information see the relevant data sheet or data handbook.

Limiting values definition — Limiting values given are in accordance with the Absolute Maximum Rating System (IEC 60134). Stress above one or more of the limiting values may cause permanent damage to the device.

These are stress ratings only and operation of the device at these or at any other conditions above those given in the Characteristics sections of the specification is not implied. Exposure to limiting values for extended periods may affect device reliability.

Application information — Applications that are described herein for any of these products are for illustrative purposes only. Philips Semiconductors make no representation or warranty that such applications will be suitable for the specified use without further testing or modification.

DISCLAIMERS

Life support applications — These products are not designed for use in life support appliances, devices, or systems where malfunction of these products can reasonably be expected to result in personal injury. Philips Semiconductors customers using or selling these products for use in such applications do so at their own risk and agree to fully indemnify Philips Semiconductors for any damages resulting from such application.

Right to make changes — Philips Semiconductors reserves the right to make changes in the products - including circuits, standard cells, and/or software - described or contained herein in order to improve design and/or performance. When the product is in full production (status 'Production'), relevant changes will be communicated via a Customer Product/Process Change Notification (CPCN). Philips Semiconductors assumes no responsibility or liability for the use of any of these products, conveys no licence or title under any patent, copyright, or mask work right to these products, and makes no representations or warranties that these products are free from patent, copyright, or mask work right infringement, unless otherwise specified.

Full bridge driver IC

UBA2032

NOTES

Full bridge driver IC

UBA2032

NOTES

Full bridge driver IC

UBA2032

NOTES

Philips Semiconductors – a worldwide company

Contact information

For additional information please visit <http://www.semiconductors.philips.com>. Fax: **+31 40 27 24825**

For sales offices addresses send e-mail to: sales.addresses@www.semiconductors.philips.com.

© Koninklijke Philips Electronics N.V. 2002

SCA74

All rights are reserved. Reproduction in whole or in part is prohibited without the prior written consent of the copyright owner.

The information presented in this document does not form part of any quotation or contract, is believed to be accurate and reliable and may be changed without notice. No liability will be accepted by the publisher for any consequence of its use. Publication thereof does not convey nor imply any license under patent- or other industrial or intellectual property rights.

Printed in The Netherlands

613502/01/pp24

Date of release: 2002 Oct 07

Document order number: 9397 750 09082

Let's make things better.

**Philips
Semiconductors**



PHILIPS

This datasheet has been download from:

www.datasheetcatalog.com

Datasheets for electronics components.