

# PQ1CG41H2FZ/PQ1CG41H2RZ

TO-220 Type Chopper Regulator built-in 300kHz oscillation circuit

## Features

- Maximum switching current: 1.5A
- Built-in ON/OFF control function
- Built-in soft start function to suppress overshoot of output voltage in power on sequence or ON/OFF control sequence
- Built-in oscillation circuit  
(Oscillation frequency: TYP. 300kHz)
- Built-in overheat, overcurrent protection functions
- TO-220 package
- Variable output voltage  
(Output variable range:  $V_{ref}$  to 35V/- $V_{ref}$  to -30V)  
[Possible to select step-down output/inverting output according to external connection circuit]
- PQ1CG41H2FZ: Zigzag forming  
PQ1CG41H2RZ: Self-stand forming

## Applications

- CTV, CTB
- LCD monitors
- Facsimiles, printers and other OA equipment
- CD-ROM drives/DVD-ROM drives

## Absolute Maximum Ratings

( $T_a=25^\circ\text{C}$ )

Parameter	Symbol	Rating	Unit
*1 Input voltage	$V_{IN}$	40	V
Error input voltage	$V_{adj}$	7	V
Input-output voltage	$V_{I-O}$	41	V
*2 Output - COM voltage	$V_{OUT}$	-1	V
*3 ON/OFF control voltage	$V_C$	-0.3 to +40	V
Switching current	$I_{SW}$	1.5	A
	$P_{D1}$	1.4	W
*4 Power dissipation	$P_{D2}$	14	W
	$T_j$	150	$^\circ\text{C}$
Operating temperature	$T_{opr}$	-20 to +80	$^\circ\text{C}$
Storage temperature	$T_{stg}$	-40 to +150	$^\circ\text{C}$
Soldering temperature	$T_{sol}$	260 (10s)	$^\circ\text{C}$

\*1 Voltage between  $V_{IN}$  terminal and COM terminal

\*2 Voltage between  $V_{OUT}$  terminal and COM terminal

\*3 Voltage between ON/OFF control and COM terminal

\*4  $P_D$ : With infinite heat sink

\*5 Overheat protection may operate at the condition  $T_j$ : 125 $^\circ\text{C}$  to 150 $^\circ\text{C}$ .

## Outline Dimensions

(Unit : mm)

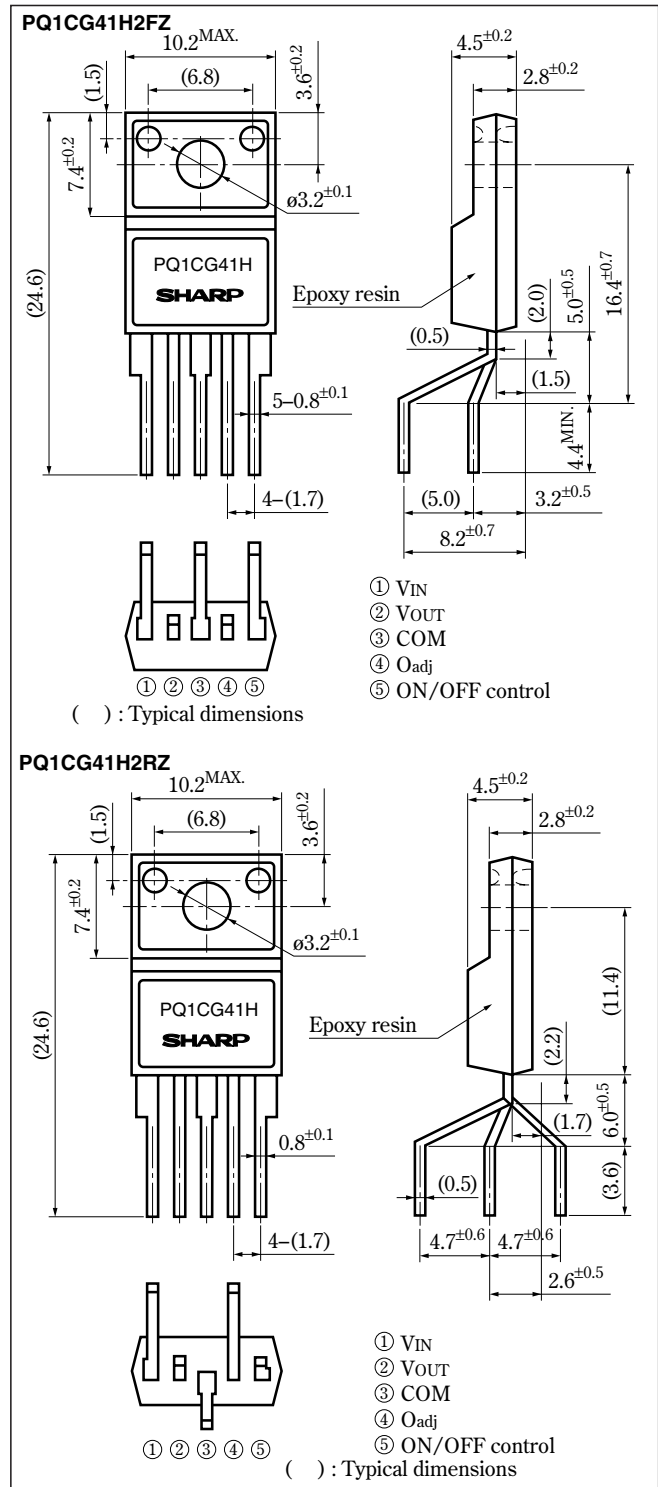

• Please refer to the chapter " Handling Precautions ".

**SHARP**

Notice In the absence of confirmation by device specification sheets, SHARP takes no responsibility for any defects that may occur in equipment using any SHARP devices shown in catalogs, data books, etc. Contact SHARP in order to obtain the latest device specification sheets before using any SHARP device.  
Internet Internet address for Electronic Components Group <http://sharp-world.com/ecg/>

**Electrical Characteristics** (Unless otherwise specified, condition shall be  $V_{IN}=12V$ ,  $I_o=0.2A$ ,  $V_o=5V$ , ON-OFF terminals is open,  $T_a=25^\circ C$ )

Parameter	Symbol	Conditions	MIN.	TYP.	MAX.	Unit
Output saturation voltage	$V_{SAT}$	$I_{sw}=1A$	-	1.0	1.5	V
Reference voltage	$V_{ref}$	-	1.235	1.26	1.285	V
Reference voltage temperature fluctuation	$\Delta V_{ref}$	$T_j=0$ to $125^\circ C$	-	$\pm 0.5$	-	%
Load regulation	$ R_{egL} $	$I_o=0.2$ to $1A$	-	0.2	1.5	%
Line regulation	$ R_{egI} $	$V_{IN}=8$ to $35V$	-	0.5	2.5	%
Efficiency	$\eta$	$I_o=1A$	-	83	-	%
Oscillation frequency	$f_o$	-	270	300	330	kHz
Oscillation frequency temperature fluctuation	$\Delta f_o$	$T_j=0$ to $125^\circ C$	-	$\pm 3$	-	%
Overcurrent detecting level	$I_L$	-	1.55	2.0	2.6	A
Charge current	$I_{CHG}$	②, ④ terminals is open, ⑤ terminal	-	-10	-	$\mu A$
Input threshold voltage	$V_{THL}$	Duty ratio=0%, ④ terminal=0V, ⑤ terminal	-	1.3	-	V
	$V_{THH}$	Duty ratio=100%, ④ terminal=1.1V, ⑤ terminal	-	2.3	-	V
ON threshold voltage	$V_{TH(ON)}$	④ terminal=0V, ⑤ terminal	0.7	0.8	0.9	V
Stand-by current	$I_{SD}$	$V_{IN}=40V$ , ⑤ terminal=0V	-	140	400	$\mu A$
Output OFF-state dissipation current	$I_{QS}$	$V_{IN}=40V$ , ④ terminal=0V, ⑤ terminal=0.9V	-	8	12	mA

Fig.1 Test Circuit

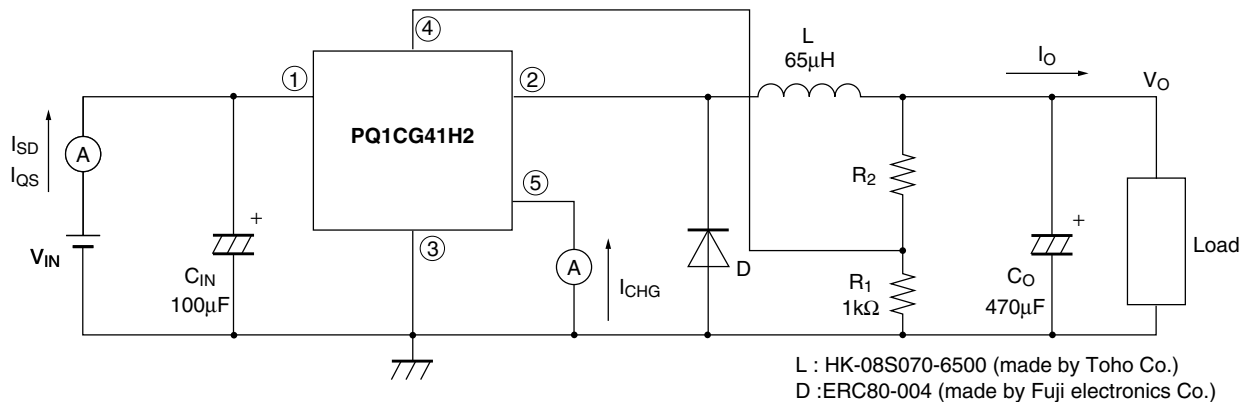
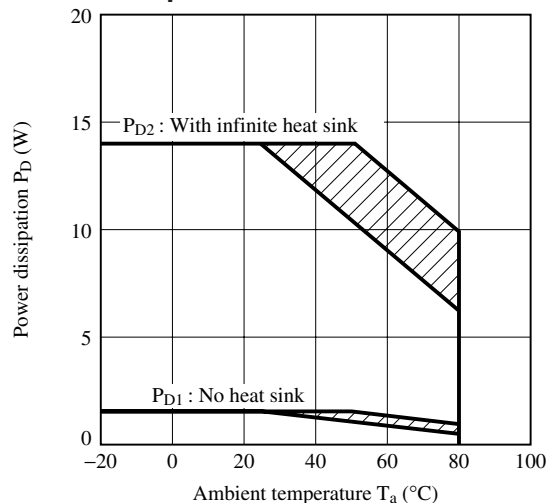

Fig.2 Power Dissipation vs. Ambient Temperature



Note) Oblique line portion: Overheat protection may operate in this area

Fig.3 Block Diagram

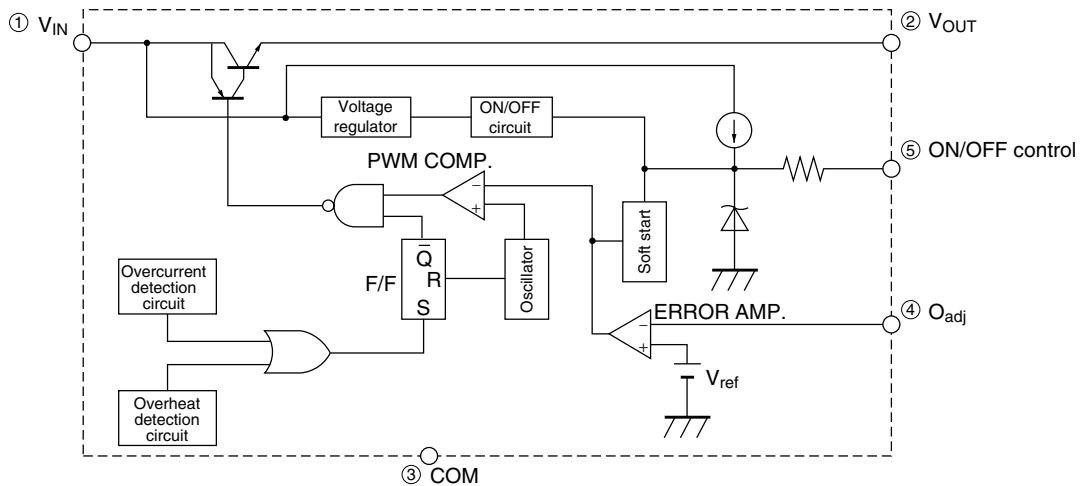

Fig.4 Step Down Type Circuit Diagram

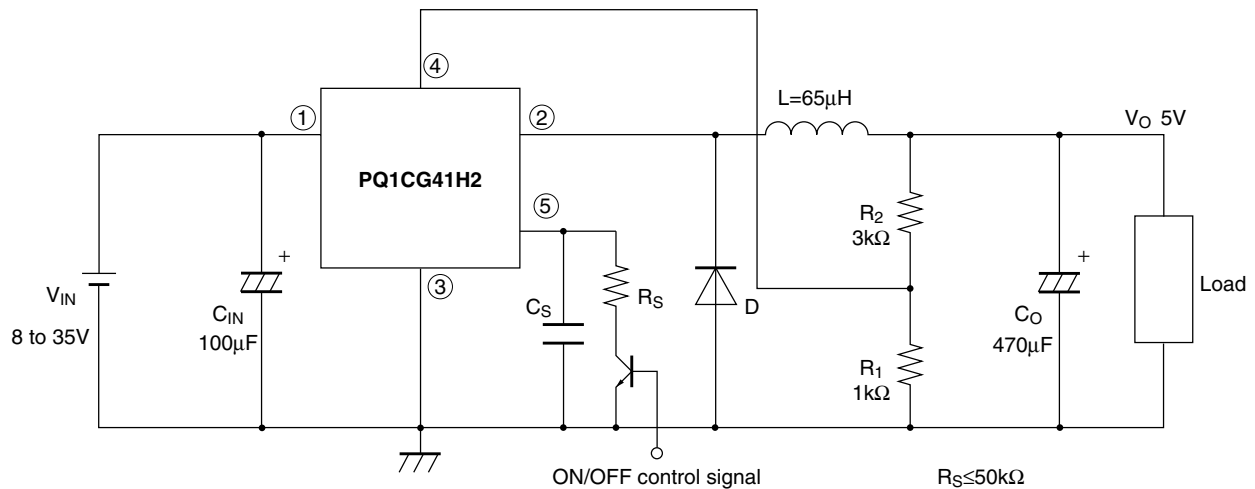
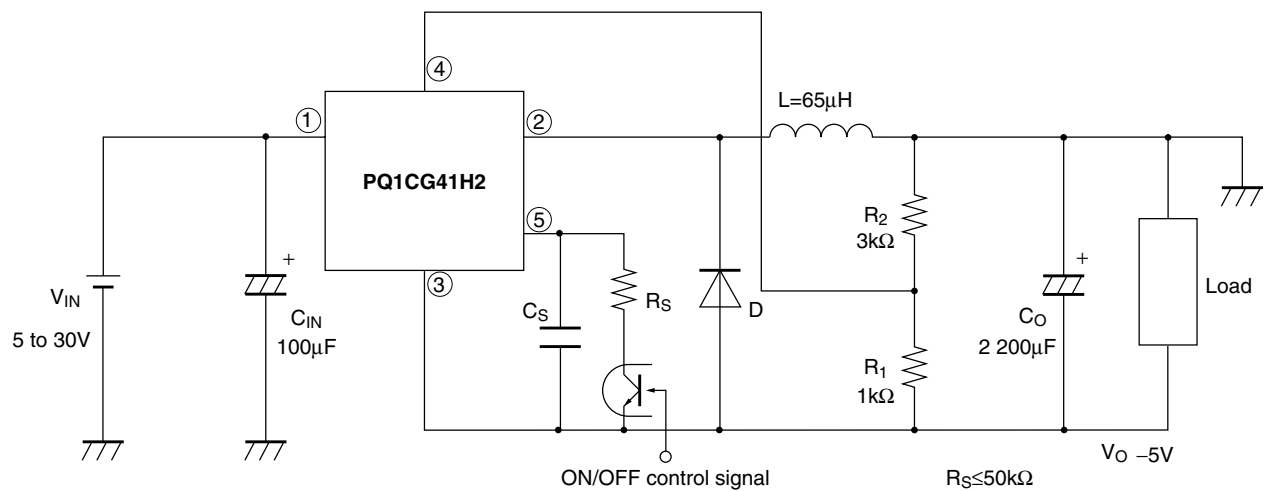

Fig.5 Polarity Inversion Type Circuit Diagram



## NOTICE

- The circuit application examples in this publication are provided to explain representative applications of SHARP devices and are not intended to guarantee any circuit design or license any intellectual property rights. SHARP takes no responsibility for any problems related to any intellectual property right of a third party resulting from the use of SHARP's devices.
- Contact SHARP in order to obtain the latest device specification sheets before using any SHARP device. SHARP reserves the right to make changes in the specifications, characteristics, data, materials, structure, and other contents described herein at any time without notice in order to improve design or reliability. Manufacturing locations are also subject to change without notice.
- Observe the following points when using any devices in this publication. SHARP takes no responsibility for damage caused by improper use of the devices which does not meet the conditions and absolute maximum ratings to be used specified in the relevant specification sheet nor meet the following conditions:
  - (i) The devices in this publication are designed for use in general electronic equipment designs such as:
    - Personal computers
    - Office automation equipment
    - Telecommunication equipment [terminal]
    - Test and measurement equipment
    - Industrial control
    - Audio visual equipment
    - Consumer electronics
  - (ii) Measures such as fail-safe function and redundant design should be taken to ensure reliability and safety when SHARP devices are used for or in connection with equipment that requires higher reliability such as:
    - Transportation control and safety equipment (i.e., aircraft, trains, automobiles, etc.)
    - Traffic signals
    - Gas leakage sensor breakers
    - Alarm equipment
    - Various safety devices, etc.
  - (iii) SHARP devices shall not be used for or in connection with equipment that requires an extremely high level of reliability and safety such as:
    - Space applications
    - Telecommunication equipment [trunk lines]
    - Nuclear power control equipment
    - Medical and other life support equipment (e.g., scuba).
- If the SHARP devices listed in this publication fall within the scope of strategic products described in the Foreign Exchange and Foreign Trade Law of Japan, it is necessary to obtain approval to export such SHARP devices.
- This publication is the proprietary product of SHARP and is copyrighted, with all rights reserved. Under the copyright laws, no part of this publication may be reproduced or transmitted in any form or by any means, electronic or mechanical, for any purpose, in whole or in part, without the express written permission of SHARP. Express written permission is also required before any use of this publication may be made by a third party.
- Contact and consult with a SHARP representative if there are any questions about the contents of this publication.