

High Efficiency 10 LED Driver with No External Schottky

FEATURES

- High efficiency boost converter with the input voltage range from 2.7 to 5.5 V
- 250 mV current sense voltage
- Drives one LED string with 10 LEDs in series up to 32 mA
- No external Schottky Required (Internal synchronous rectifier*)
- 0.7 MHz Switching Frequency
- Efficiency greater than 83%
- Smart OneWire™ Interface and PWM LED Brightness Control Modes Provide Constant I_{LED} current or constant color temperature brightness control
- Small External Inductor (10 μ H – 33 μ H)
- Over voltage, under voltage, over temperature, over current protection
- Low Shutdown Current (<1 μ A)
- Available in 2 x 3 x 0.8 mm 8-pin TDFN package

APPLICATION

- Color Display Backlight
- Portable Navigation and GPS Receivers
- Smart phones
- Digital Photo Frames
- Portable DVD Players
- Multimedia Phones

DESCRIPTION

The LDS8711 is a fixed frequency current mode boost converter with internal rectifier and cycle-by-cycle switch current limit specifically designed to drive a string of up to 10 White LEDs. It operates

either in PWM or in Smart OneWire™ Interface mode. The Smart OneWire™ Interface mode allows set LED current in the range from 0.125 to 32 mA in 256 steps of 0.125 mA each. In PWM mode, LDS8711 operates with either factory, or customer preset maximum LED current values. Series connection of the LEDs provides constant current and subsequently uniform brightness, eliminating the need for ballast resistors and factory calibration. Operation at 0.7 MHz allows use of small value inductor (10 – 33 μ H) and external ceramic capacitor (1 – 2.2 μ F).

The use of integrated rectifier makes the efficiency dependent on only two external components parameters: inductor DCR and external capacitor ESR.

The supply voltage down to 2.7 V for new Li-ion battery chemistries or two alkaline battery cells extends the battery life. Under-voltage protection disables the part when V_{IN} voltage reaches 2.0 V

The LDS8711 has thermal shutdown set at 150 °C. Above this value, the boost converter stops switching. The part resumes normal operations when temperature drops below 130 °C.

The over-current protection provides cycle-by-cycle current limit.

The internal output over-voltage protection prevents damage in the case of a faulty LED disconnect.

The PWM control ensures brightness adjustment with a frequency from 100 Hz up to 30 KHz.

The EN/PWM logic input functions as a chip enable and LED current PWM control pin.

The device is available in in 8-pin TDFN 2 x 3 mm package with a max height of 0.8 mm.

TYPICAL APPLICATION CIRCUIT

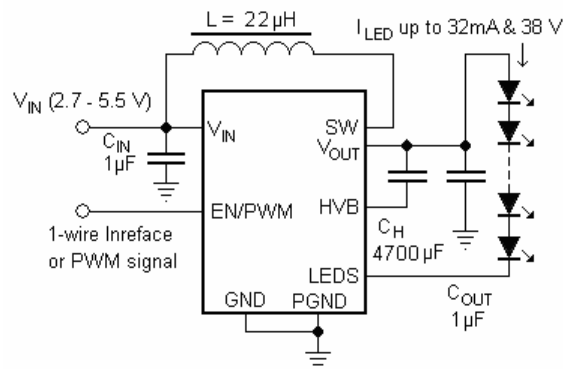

*) Patent pending

ABSOLUTE MAXIMUM RATINGS

Parameter	Rating	Unit
V _{IN} voltage	6	V
V _{OUT} , SW, LEDS, Vh voltage	40	V
EN/SET voltage	V _{IN} + 0.7V	V
LED Current	32	mA
Storage Temperature Range	-65 to +160	°C
Junction Temperature Range	-40 to +125	°C
8-pin TDFN package Thermal Resistance	65	°C/W
Soldering Temperature	300	°C

RECOMMENDED OPERATING CONDITIONS

Parameter	Rating	Unit
V _{IN}	2.7 to 5.5	V
Ambient Temperature Range	-40 to +85	°C

Typical application circuit with external components is shown on page 1.

ELECTRICAL OPERATING CHARACTERISTICS

(Over recommended operating conditions unless specified otherwise) V_{IN} = 3.6V, T_{AMB} = 25°C, C_{IN} = 1 μF, C_{OUT} = 1 μF, L = 22 μH

Name	Conditions	Min	Typ	Max	Units
Quiescent Current	V _{IN} = 3.6 V, V _{OUT} open		1		mA
	V _{IN} = 3.6 V, I _{LED} = 25 mA @ V _{OUT} = 36 V		3		
Shutdown Current	V _{IN} = 5.5V, EN = 0V			1	μA
LED Current Accuracy	At factory preset value		±1		%
Oscillator Frequency			0.7		MHz
Maximum Duty Cycle			92		%
NMOSFET Switch On Resistance			0.3		Ω
PMOSFET Switch On Resistance			1.5		Ω
Switch Leakage Current				0.1	μA
Switch Current Limit			1.3		A
Dropout/Current sense voltage	At factory preset value		250		mV
PWM Frequency		0.1		30	kHz
EN/PWM Pin	Input Resistance (pull down)			250	kΩ
	Logic Level	High	1.4		V
		Low			
Thermal Shutdown			150		°C
Thermal Hysteresis			20		
Over-Voltage Protection			36		V
Soft Start Time			1.5		ms
Delay Time to Shutdown	EN = 0		10		ms

Smart OneWire™ TIMING SPECIFICATION

Parameter	Name	Min	Typ	Max	Units
t_{SETUP1}	EN/PWM setup from shutdown to PWM mode	50	100	200	μ s
t_{SETUP2}	EN/SET setup from shutdown to Smart OneWire™ Interface mode	350			μ s
t_{B0}	Bit “zero” positive pulse	1		25	μ s
t_{B1}	Bit “one” positive pulse	40		200	μ s
t_{CLO}	Low time between command pulses or two command sets	2	25	200	μ s
t_{LO}	EN LOW Time before LED ON in PWM mode	0.002		8	ms
t_{LO1}	EN LOW Time before LED ON in OneWire™ interface mode	0.3		5	ms
t_{OFF}	EN/SET low time to shutdown	10			ms

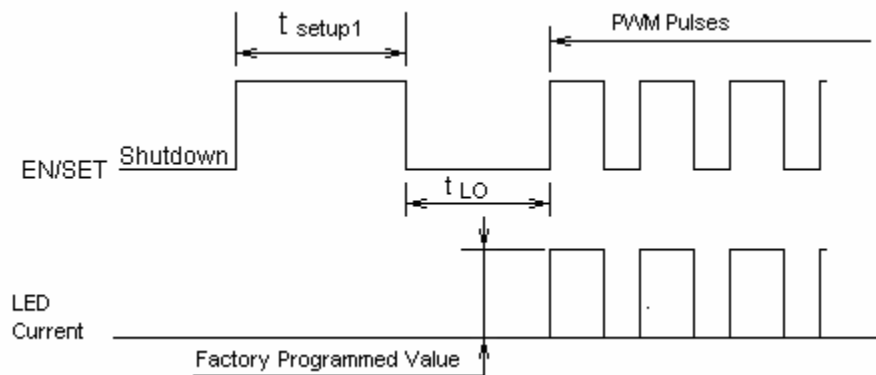

Fig. 1. PWM Mode operation

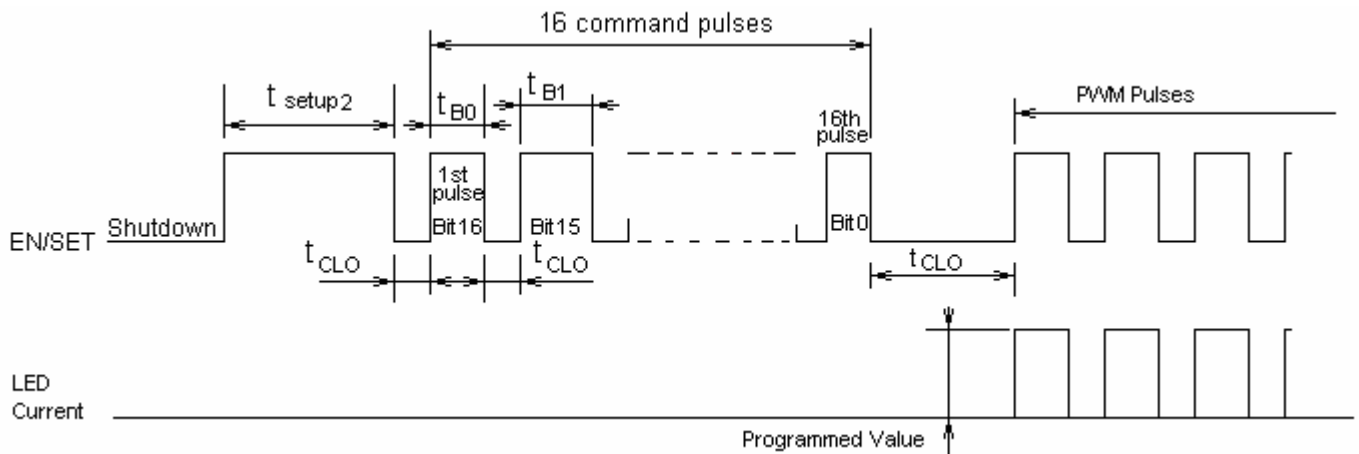

Fig. 2 LED Current programming

Table 1: Smart OneWire™ interface commands

Command description	Command															
	Register address						Data									
	Bit 15	Bit 14	Bit 13	Bit 12	Bit 11	Bit 10	Bit 9	Bit 8	Bit 7	Bit 6	Bit 5	Bit 4	Bit 3	Bit 2	Bit 1	Bit 0
Current Setting	0	0	0	0	0	1	0	0	LED Current Binary Code = $(I_{LED} / 0.125 \text{ mA} - 1)$ (bin), where $0.125 \text{ mA} < I_{LED} < 32 \text{ mA}$							

TYPICAL CHARACTERISTICS

$V_{in} = 3.6V$, $I_{OUT} = 30mA$ (10 LEDs per string), $C_{IN} = 1 \mu F$, $C_{OUT} = 1 \mu F$, $L = 22 \mu H$, $T_{AMB} = 25^{\circ}C$ unless otherwise specified

Power Efficiency vs. Input Voltage

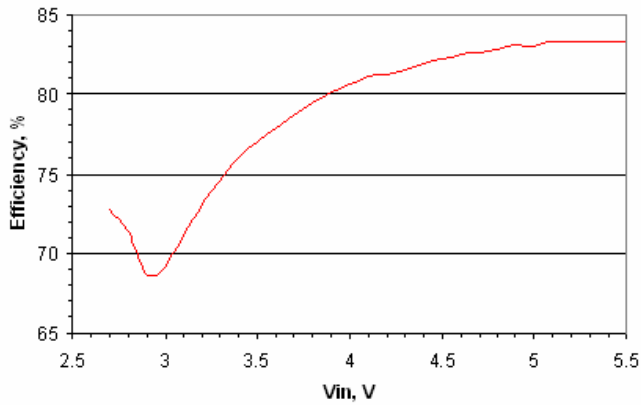

LED Current vs. Input Voltage

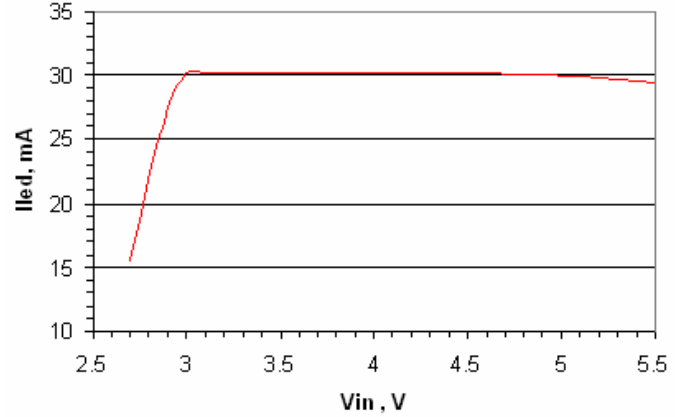

LED Current vs. PWM Duty Cycle

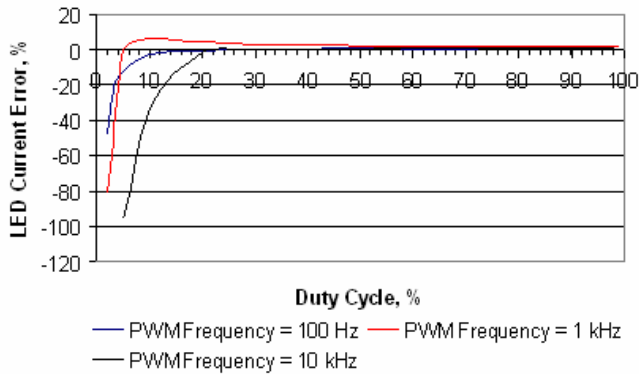

LED Current Error vs. PWM Frequency

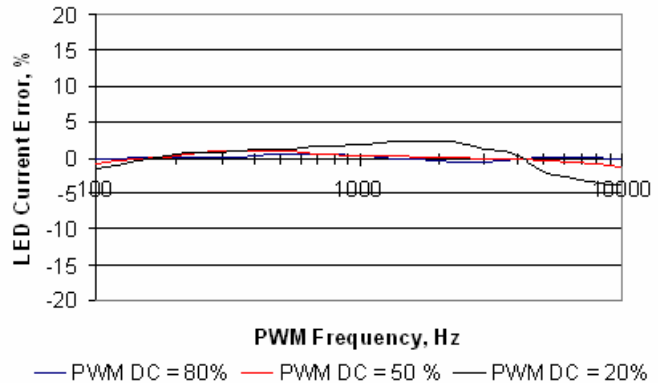

Soft Start Waveforms

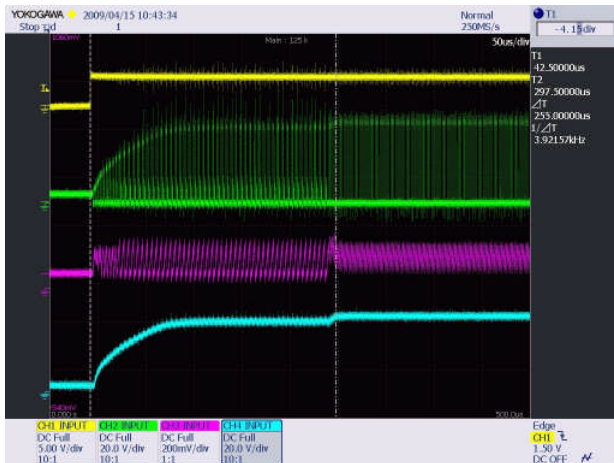

Ch 1 (yellow) – EN pin, Ch 2 (green) – SW node voltage
Ch 3 (red) – Inductor current, Ch 4 (blue) – V_{out}

Operating Waveforms

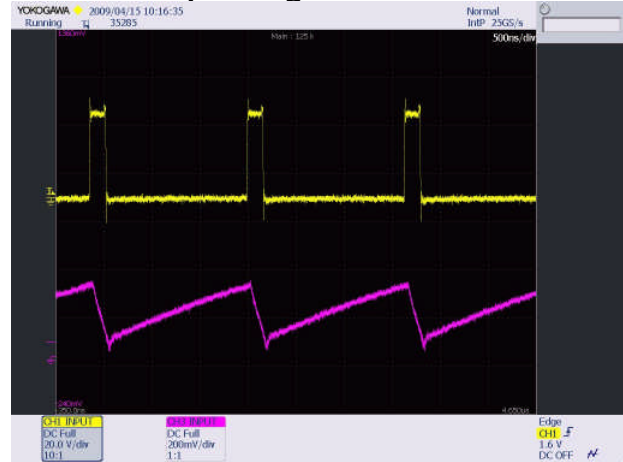

Ch 1 (yellow) - SW node voltage,
Ch 3 (red) – Inductor current

TYPICAL CHARACTERISTICS

$V_{in} = 3.6V$, $I_{OUT} = 30mA$ (10 LEDs per string), $C_{IN} = 1\mu F$, $C_{OUT} = 1\mu F$, $L = 22\mu H$, $T_{AMB} = 25^{\circ}C$ unless otherwise specified

Waveforms at PWM LED Current Regulation

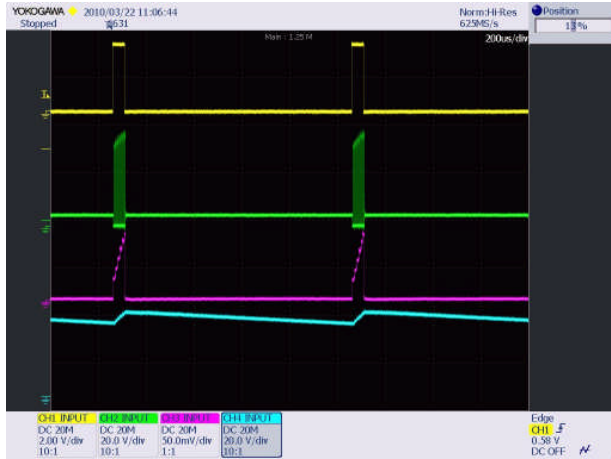

Ch 1 (yellow) – PWM signal at 1 kHz 5% duty cycle
 Ch 2 (green) – SW node voltage, Ch 3 (red) – LED Current.
 Ch 4 (blue) – V_{OUT}

Waveforms at PWM LED Current Regulation



Ch 1 (yellow) – PWM signal at 1 kHz 98% duty cycle
 Ch 2 (green) – SW node voltage, Ch 3 (red) – LED Current.
 Ch 4 (blue) – V_{OUT}

Waveforms at PWM LED Current Regulation

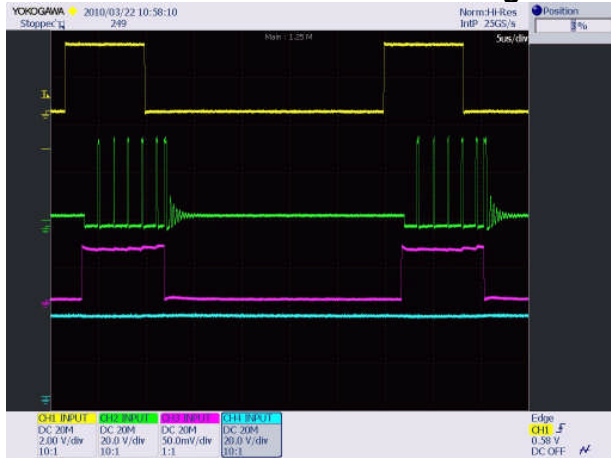

Ch 1 (yellow) – PWM signal at 30 kHz 25% duty cycle
 Ch 2 (green) – SW node voltage, Ch 3 (red) – LED Current.
 Ch 4 (blue) – V_{OUT}

Waveforms at PWM LED Current Regulation

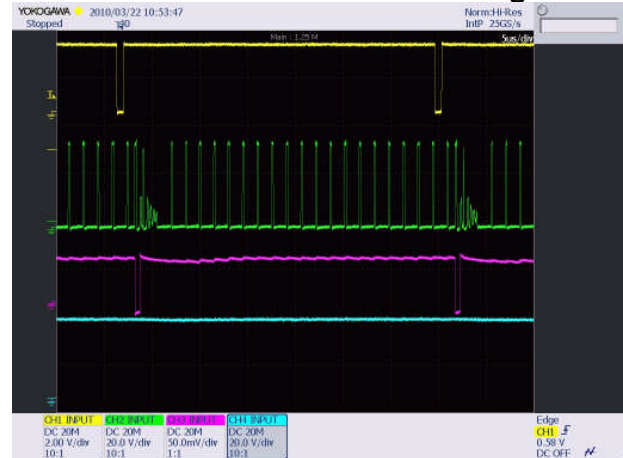

Ch 1 (yellow) – PWM signal at 30 kHz 98% duty cycle
 Ch 2 (green) – SW node voltage, Ch 3 (red) – LED Current.
 Ch 4 (blue) – V_{OUT}

PIN DESCRIPTION

Pin #	Name	Function
1	V _{IN}	Input Voltage, connect to battery or power supply
2	GND	Analog Ground
3	PGND	Power Ground
4	SW	Switch input; Connect inductor terminal to this pin
5	V _{OUT}	Output voltage; Connect to the LED string anode terminal to this pin.
6	HVB	High Voltage Bypass; Connect a 0.01 μ F capacitor between this point and V _{OUT}
7	LEDS	Current Sense input. Connect LED string cathode terminal to this pin
8	EN/PWM	Device Enable (active high) and Dimming Control
PAD	PAD	Connect to GND on the PCB

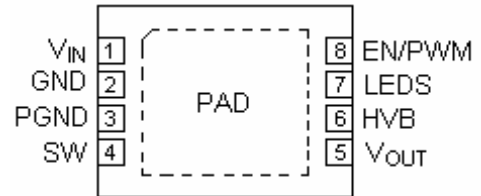

Top view: TDFN 8-lead 2 X 3 mm

PIN FUNCTION

V_{IN} is the supply pin for the driver. A small 1 μ F ceramic bypass capacitor is required between the V_{IN} pin and ground near the device. The operating input voltage range is from 2.7 V to 5.5 V. If the input supply voltage falls below the under-voltage threshold, switch is disabled, and the device enters shutdown mode.

HVB is the internal high voltage reference point. Connect a 4700 μ F capacitor between this point and V_{OUT}.

EN/PWM is the Enable/Smart OneWire™ interface and PWM control logic input. Guaranteed levels of logic high and logic low are set at 1.4 V and 0.4 V respectively. When EN/PWM is initially taken high, the device becomes enabled and wait for the first pulse that determines mode, at which device will operate. If first pulse is equal t_{SETUP1}, LED current sets to factory programmed value and every next incoming pulse will be recognized as PWM signal. If first pulse is equal t_{SETUP2}, device enters Smart OneWire™ interface mode and wait for command. Every next of 16 incoming pulses will be recognized as command. If device is not able to recognize command due error in transmission, it enters shutdown

mode after 10 ms. To place the device into shutdown mode, the EN/PWM pin must be held low for more than 10 ms.

V_{OUT} is the driver' output that is connected to the LED anode. A ceramic bypass capacitor is required between the V_{OUT} pin and ground near the device.

GND is the ground reference for the analog circuits. The pin must be connected to the ground plane on the PCB. Avoid high currents flowing trough traces connecting this pin with EN/PWM signal source.

PGND is the current return for high current circuits. The pin must be connected to the ground plane on the PCB. Connect GND and PGND as close to the driver as possible.

LEDS is the Current Sense pin that provides internal regulated current sink for LED string. Connect LED string cathode to this pin. This pin enter high-impedance zero current state whenever the device is in shutdown mode.

PAD is the exposed pad underneath the package. For best thermal performance, the pad should be soldered to the PCB and connected to the ground plane

BLOCK DIAGRAM

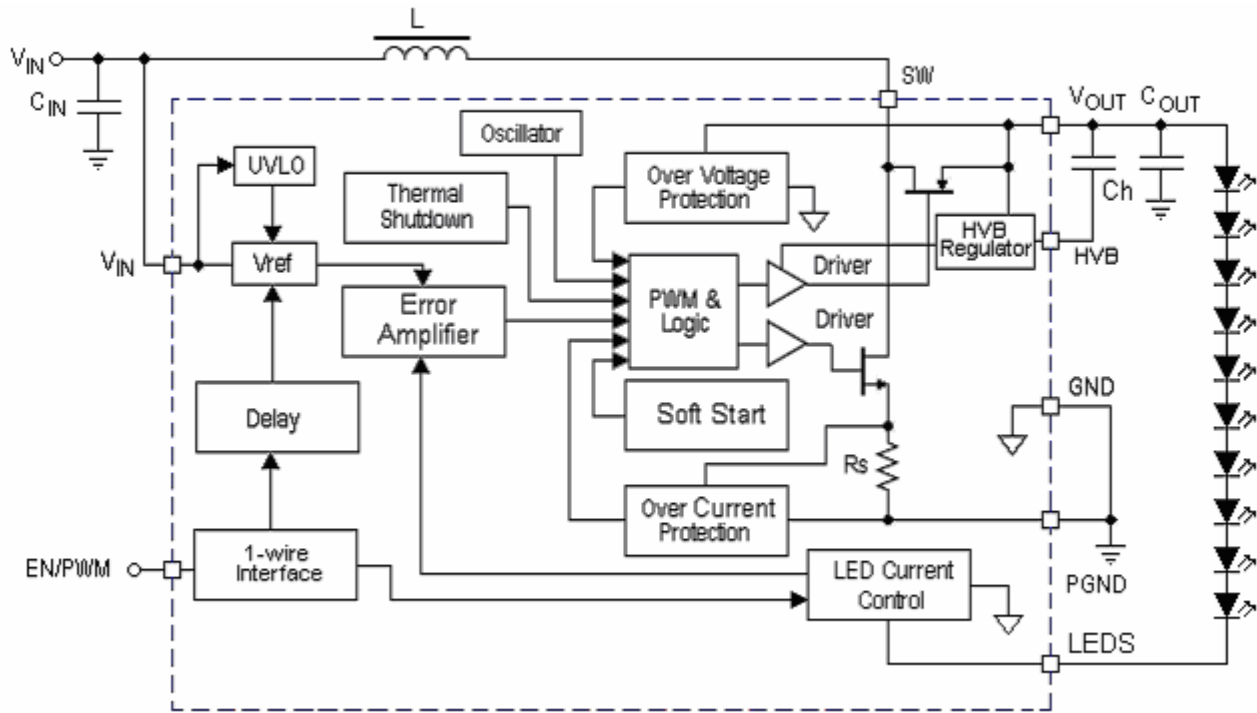

Figure 3. LDS8711 Functional Block Diagram

BASIC OPERATION

At power-up, EN/PWM pin should be logic LOW. The LDS8711 starts operating when EN/PWM pin is asserted logic high. The device becomes enabled and wait for the first pulse that determines mode, at which device will operate. If first pulse is equal t_{SETUP1} , LED current sets to factory programmed value and every next incoming pulse will be recognized as PWM signal. If first pulse is equal t_{SETUP2} , device enters Smart OneWire™ interface mode and wait for command. Every next of 16 incoming pulses will be recognized as command. After LDS8711 accepts command, the current sets in respect to programmed value, and device changes mode to PWM. If device is not able to recognize command due some error, it enters shutdown mode after 10 ms.

If the input voltage is sufficient to regulate all LED currents, the device remains in operating mode. The low dropout Current regulator performs well at V_{OUT} voltage up to 250 mV above summary LED forward voltage significantly increasing driver's efficiency.

If the input voltage is insufficient or falls to a level where the regulated currents cannot be maintained, the Under-Voltage protection turns device off setting it in shutdown mode.

The LDS8711 has soft start function that prevent high input current spike at device' wake-up.

The EN/PWM pin should be held low for more than 10 ms to completely turn device in low current shutdown mode.

LED Current Setting

The maximum current value in the LED string may be factory preset in the range from 10 to 30 mA in 0.125 mA steps, or set by Smart OneWire™ interface in the range from 0.125 to 32 mA. The average LED string current that determines LED brightness may be controlled applying PWM signal to the EN/PWM pin. The maximum PWM frequency is 30 kHz, while frequencies below 100 Hz are not recommended to avoid visible LED flickering. Duty cycle that determines average LED string current may vary in the range from 5% to 100% at 1 kHz or from 20% to 100% at 30 kHz with high linearity current regulation.

It gives possibility regulate brightness either in DC mode with changing color temperature, or in PWM mode with stable color temperature.

To start LDS8711 in PWM Mode, the first positive pulse applied to EN/PWM pin after power-up should be equal t_{SETUP1} and followed by EN/PWM pin LOW

state equal t_{LO} (see Figure 1). Every next incoming pulse will be recognized as PWM pulse, and maximum LED current will be set equal factory preset value. If PWM frequency is above 5 kHz and duty cycle is less than 50%, device will start in PWM mode automatically; however, at lower frequencies or 100% duty cycle, start procedure requires.

To start LDS8711 in Smart OneWire™ Interface Mode, the first positive pulse applied to EN/PWM pin after power-up should be equal t_{SETUP2} and followed by 16 command pulses in respect to Smart OneWire™ interface command shown in the Table 1.

Every Smart OneWire™ interface command to program LED current may be represented in binary code as 0000 0100 XXXX XXXX (MSB to LSB), where X is a bit value in respect with desired current value.

Example:

If desired LED current value is 22 mA, binary code is equal $22 \text{ mA} / 0.125 \text{ mA} - 1 = 43$ (Dec) = 1010 1111 (Bin) and Smart OneWire™ interface command to set this current is: 0000 0100 1010 1111 (MSB to LSB).

This command should be send (MSB first) through EN/PWM pin as sequence of 16 pulses, each of which represents bit zero or bit one depend on pulse length that should be equal t_{B0} or t_{B1} respectively (see *Smart OneWire™ TIMING SPECIFICATION*).

After 16th pulse, EN/PWM pin should be LOW for t_{LO1} time to confirm end of the command and transfer to PWM mode. Every next incoming pulse will be recognized as PWM pulse, and it will turn LEDs on (see Figure 2).

If LDS8711 is not able recognize command due some error in programming or transmit, it will go in shutdown mode after 10 ms timeout

Once in PWM mode, LDS8711 is not able recognize Smart OneWire™ Interface commands and requires restart to reprogram LED current.

Protection Mode

The output voltage V_{OUT} is limited at about 38 V maximum. This is to prevent the output pin from exceeding its absolute maximum rating if LED string is disconnected or any LED in string burns out creating open circuitry.

If the die temperature exceeds +150°C, the driver will enter a thermal protection shutdown mode. When the device temperature drops by about 20°C, the device will resume normal operation.

LED Selection

LEDs with forward voltages (V_F) ranging from 1.3 V to 5.0 V may be used. However, number of the LEDs in string is limited by maximum output voltage that cannot exceed over-voltage protection level. We recommend using not more than 10 LEDs with $V_F \leq 3.6 \text{ V}$ in string if V_{IN} voltage is above 3.0 V and not more that eight LEDs if V_{IN} may fall up to 2.7 V.

External Components

The LDS8711 requires four external components only. The recommended input capacitor value is between 1 and 10 μF , while the output capacitor selection is function of desired output ripple, loop stability, and inrush current.

The inductor should have minimum Rdc resistance to increase driver's efficiency. Recommended inductor values are from 10 to 33 μH . The inductor ripple current I_R is a function of switching frequency, inductor value, and duty cycle and is determined by the following equation:

$$I_R = \frac{1}{Lf \left(\frac{1}{NV_F + V_d + V_{PM} - V_{IN}} + \frac{1}{V_{IN}} \right)},$$

where

V_F - is a LED forward voltage,

V_d - is a current regulator voltage drop,

V_{PM} - is a voltage drop across PMOSFET,

V_{IN} - is an input voltage,

L is - inductance, and

f - is a switching frequency, 700 kHz.

Then, the switch cycle-by-cycle current limit is equal:

$$I_{LIM} = \frac{I_{OUT} (NV_F + V_d)}{V_{IN} \eta} + \frac{I_R}{2},$$

where η is expected efficiency.

The selected inductor should allow around 20% higher peak current to avoid saturation.

The criterion for the output capacitor selection is:

$$C_{OUT} = \frac{(NV_F + V_d - V_{IN}) I_{OUT}}{(NV_F + V_d) V_R f}$$

For example:

If $V_{IN} = 2.7 \text{ V}$, $N = 10$, $V_F = 3.6 \text{ V}$, $V_d = 0.25 \text{ V}$, $f = 0.7 \text{ MHz}$, $I_{OUT} = 30 \text{ mA}$, and ripple voltage $V_R = 0.05 \text{ V}$, $C_{OUT} = 0.77 \mu\text{F}$ so 1.0 μF is a good choice.

LDS8711

We recommend C_{OUT} in the range 1.0 – 2.2 μF to achieve better efficiency and driver's stability.

Recommended Layout

In active mode, the driver switches internally at a high frequency. We recommend minimize trace length to all external capacitors and inductor. The input and output ceramic capacitors (X5R or X7R type) should be located as close to the device' pins as possible to prevent from EMI distribution

A ground plane should cover the area under the driver IC as well as the bypass capacitors. Short connection to ground on capacitors C_{IN} and C_{OUT} can be implemented with the use of multiple via. A copper area matching the TDFN exposed pad (PAD) must be connected to the ground plane underneath. The

use of multiple via improves the package heat dissipation.

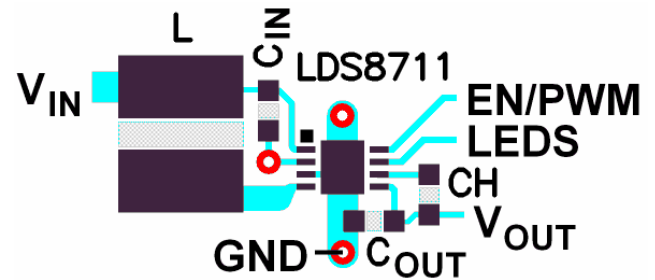
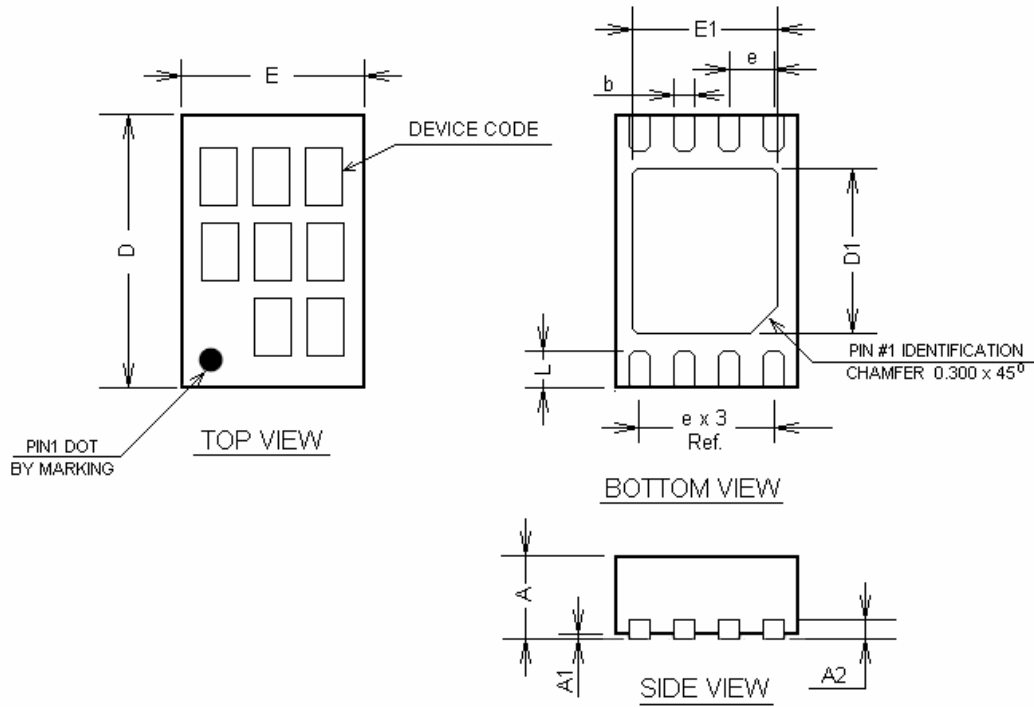

Figure 4. Recommended layout

PACKAGE DRAWING AND DIMENSIONS

8-PIN TDFN, 2mm x 3mm, 0.5mm PITCH



SYMBOL	MIN	NOM	MAX
A	0.700	0.750	0.800
A1	-	0.000	0.050
A2		0.203 Ref.	
b	0.180	0.230	0.280
D	2.950	3.000	3.050
D1	1.750	1.800	1.850
E	1.950	2.000	2.050
E1	1.550	1.600	1.650
e		0.500 Bsc	
L	0.350	0.400	0.450

Note:

1. All dimensions are in millimeters
2. Complies with JEDEC Standard MO-220

ORDERING INFORMATION

Part Number	Package	Package Marking
LDS8711 008-T2 – 300 ¹⁾	TDFN - 8 2 x 3mm ²⁾	711

Notes:

1. Maximum LED current is factory preset at 20, 25, or 30 mA. Consult factory if other current values are required.
2. Matte-Tin Plated Finish (RoHS-compliant)
3. Quantity per reel is 2000

EXAMPLE OF ORDERING INFORMATION

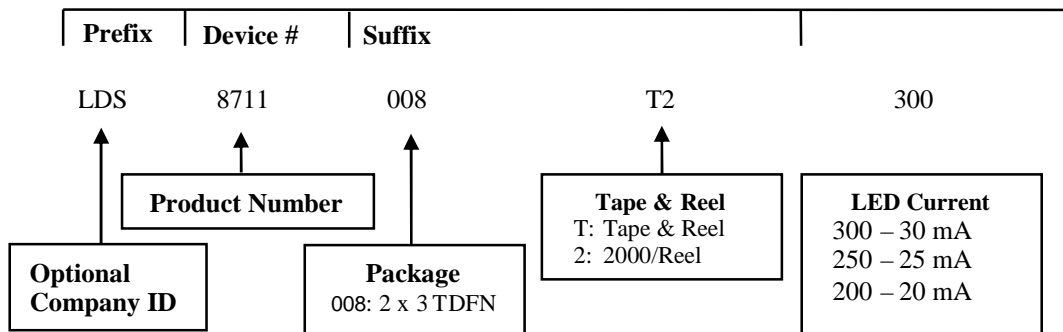

Notes:

- 1) All packages are RoHS-compliant (Lead-free, Halogen-free).
- 2) The standard lead finish is Matte-Tin.
- 3) The device used in the above example is a LDS8711 XXX-T2-300 (2x3 TDFN, Tape & Reel, 30 mA LED Current).
- 4) For additional package and current options, please contact your nearest IXYS Corp. Sales office.

Warranty and Use

IXYS CORP. MAKES NO WARRANTY, REPRESENTATION OR GUARANTEE, EXPRESS OR IMPLIED, REGARDING THE SUITABILITY OF ITS PRODUCTS FOR ANY PARTICULAR PURPOSE, NOR THAT THE USE OF ITS PRODUCTS WILL NOT INFRINGE ITS INTELLECTUAL PROPERTY RIGHTS OR THE RIGHTS OF THIRD PARTIES WITH RESPECT TO ANY PARTICULAR USE OR APPLICATION AND SPECIFICALLY DISCLAIMS ANY AND ALL LIABILITY ARISING OUT OF ANY SUCH USE OR APPLICATION, INCLUDING BUT NOT LIMITED TO, CONSEQUENTIAL OR INCIDENTAL DAMAGES.

IXYS Corp. products are not designed, intended, or authorized for use as components in systems intended for surgical implant into the body, or other applications intended to support or sustain life, or for any other application in which the failure of the IXYS Corp. product could create a situation where personal injury or death may occur.

IXYS Corp. reserves the right to make changes to or discontinue any product or service described herein without notice. Products with data sheets labeled "Advance Information" or "Preliminary" and other products described herein may not be in production or offered for sale.

IXYS Corp. advises customers to obtain the current version of the relevant product information before placing orders. Circuit diagrams illustrate typical semiconductor applications and may not be complete.



IXYS Corp.
1590 Buckeye Dr.,
Milpitas, CA 95035-7418
Phone: 408.457.9000
Fax: 408.496.0222
<http://www.ixys.com>

Document No: 8711DS
Revision: N1.0
Issue date: 6/28/2010