

FAN5307 High-Efficiency Step-Down DC-DC Converter

Features

- 95% Efficiency, Synchronous Operation
- Adjustable Output Voltage Option from 0.7V to V_{IN}
- 2.5V to 5.5V Input Voltage Range
- Customized Fixed Output Voltage Options
- Up to 300mA Output Current
- Fixed Frequency 1MHz PWM Operation
- High Efficiency Power Save Mode
- 100% Duty Cycle Low Dropout Operation
- Soft Start
- Dynamic Output Voltage Positioning
- 15 μ A Quiescent Current
- Excellent Load Transient Response
- 5-Lead SOT-23 Package
- 6-Lead MLP 3x3mm Package

Applications

- Pocket PCs, PDAs
- Cell Phones
- Battery-Powered Portable Devices
- Digital Cameras
- Low Power DSP Supplies

General Description

The FAN5307, a high efficiency low noise synchronous PWM current mode and Pulse Skip (Power Save) mode DC-DC converter is designed for battery-powered applications. It provides up to 300mA of output current over a wide input range from 2.5V to 5.5V. The output voltage can be either internally fixed or externally adjustable over a wide range of 0.7V to 5.5V V_{IN} by an external voltage divider. Custom output voltages are also available. Contact a Fairchild sales representative for customized output voltage options.

At moderate and light loads pulse skipping modulation is used. Dynamic voltage positioning is applied, and the output voltage is shifted 0.8% above nominal value for increased headroom during load transients. At higher loads the system automatically switches to current mode PWM control, operating at 1 MHz. A current mode control loop with fast transient response ensures excellent line and load regulation. In Power Save mode, the quiescent current is reduced to 15 μ A in order to achieve high efficiency and to ensure long battery life. In shut-down mode, the supply current drops below 1 μ A. The device is available in 5-lead SOT-23 and 6-lead MLP 3x3mm packages.

Typical Application

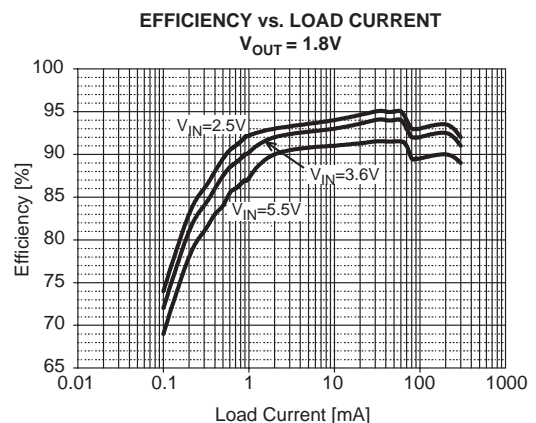
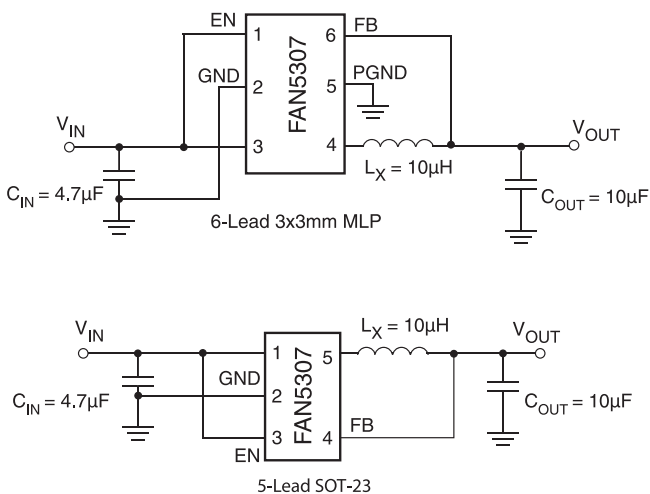

Pin Assignment

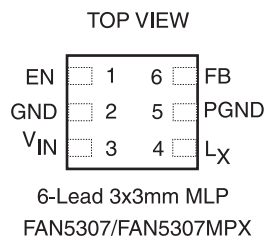
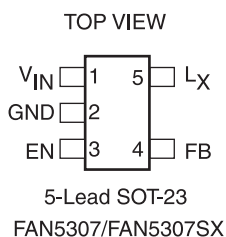

Pin Description

5-Lead SOT-23

Pin No.	Pin Name	Pin Description
1	V_{IN}	Supply voltage input.
2	GND	Ground.
3	EN	Enable Input. Logic high enables the chip and logic low disables the chip and reduces supply current to $<1\mu\text{A}$. Do not float this pin.
4	FB	Feedback Input. In case of fixed voltage options, connect this pin directly to the output. For an adjustable voltage option, connect this pin to the resistor divider.
5	L_X	Inductor pin. This pin is connected to the internal MOSFET switches.

6-Lead 3x3mm MLP

Pin No.	Pin Name	Pin Description
1	EN	Enable Input. Logic high enables the chip and logic low disables the chip and reduces supply current to $<1\mu\text{A}$. Do not float this pin.
2	GND	Reference ground.
3	V_{IN}	Supply voltage input.
4	L_X	Inductor pin. This pin is connected to the internal MOSFET switches.
5	PGND	Power ground. Internal N-channel MOSFET is connected to this pin.
6	FB	Feedback Input. In case of fixed voltage options, connect this pin directly to the output. For an adjustable voltage option, connect this pin to the resistor divider.

Absolute Maximum Ratings

Parameter		Min	Max	Unit
V_{IN}		-0.3	6.5	V
Voltage on any other pin		GND-0.3	$V_{IN} + 0.3$	V
Thermal Resistance (Note 1)	Junction to case, SOT-23		130	°C/W
	Junction to tab, MLP 3x3		8	
Lead Soldering Temperature (10 seconds)			260	°C
Storage Temperature		-65	150	°C
Electrostatic Discharge (ESD) Protection Level (Note 2)	HBM	4		kV
	CDM	1		

Recommended Operating Conditions

Parameter	Min	Typ	Max	Unit
Supply Voltage Range	2.5		5.5	V
Output Voltage Range, Adjustable Version	0.7		V_{IN}	V
Output Current			300	mA
Inductor (Note 3)		10		μH
Input Capacitor (Note 3)		4.7		μF
Output Capacitor (Note 3)		10		μF
Operating Ambient Temperature Range	-40		+85	°C
Operating Junction Temperature Range	-40		+125	°C

Notes:

1. Junction to ambient thermal resistance, θ_{JA} , is a strong function of PCB material, board thickness, thickness and number of copper planes, number of vias used, diameter of via used, available copper surface, and attached heat sink characteristics.
2. Using Mil Std. 883E, method 3015.7(Human Body Model) and EIA/JESD22C101-A (Charge Device Model).
3. Refer to the applications section for further details.

General Electrical Characteristics

$V_{IN} = 2.5V$ to $5.5V$, $I_{OUT} = 200mA$, $EN = V_{IN}$, $C_{IN} = 4.7\mu F$, $C_{OUT} = 22\mu F$, $L_X = 10\mu H$, $T_A = -40^\circ C$ to $+85^\circ C$, unless otherwise noted. Typical values are at $T_A = 25^\circ C$.

Parameter	Conditions	Min.	Typ.	Max.	Units
	Input Voltage	2.5		5.5	V
Quiescent Current	$I_{OUT} = 0mA$, Device is not switching		15	30	μA
Shutdown Supply Current	$EN = GND$		0.1	1	μA
Enable High Input Voltage		1.3			V
Enable Low Input Voltage				0.4	V
En Input Bias Current	$EN = V_{IN}$ or GND		0.01	0.1	μA
PMOS On Resistance	$V_{IN} = V_{GS} = 3.6V$		530	690	$m\Omega$
	$V_{IN} = V_{GS} = 2.5V$		670	850	
NMOS On Resistance	$V_{IN} = V_{GS} = 3.6V$		430	540	$m\Omega$
	$V_{IN} = V_{GS} = 2.5V$		530	660	
P-channel Current Limit	$2.5V < V_{IN} < 5.5V$	400	520	700	mA
N-channel Leakage Current	$V_{DS} = 5.5V$		0.1	1	μA
P-channel Leakage Current	$V_{DS} = 5.5V$		0.1	1	μA
Switching Frequency		800	1000	1200	kHz
Line Regulation	$V_{IN} = 2.5$ to $5.5V$, $I_{OUT} = 10mA$		0.16		% / V
Load Regulation (6-Lead 3x3mm MLP)	$100mA \leq I_{OUT} \leq 300mA$		0.0014		% / mA
Load Regulation (5-Lead SOT-23)	$100mA \leq I_{OUT} \leq 300mA$		0.0022		% / mA
Output Voltage Accuracy (5-Lead SOT-23)	$V_{IN} = 2.5$ to $4.5V$, $0mA \leq I_{OUT} \leq 300mA$	-4		4	%
	$V_{IN} = 2.5$ to $5.5V$, $0mA \leq I_{OUT} \leq 300mA$	-5		4	%
Leakage Current into SW Pin	$V_{IN} > V_{OUT}$, $0V \leq V_{SW} \leq V_{IN}$		0.1	1	μA
Reverse Leakage Current into pin SW	$V_{IN} = \text{Open}$, $EN = GND$, $V_{SW} = 5.5V$		0.1	1	μA
Output Voltage Accuracy (6-Lead 3x3mm MLP)	$V_{IN} = 2.5$ to $5.5V$, $0mA \leq I_{OUT} \leq 300mA$	-4		4	%

Electrical Characteristics for Adjustable Version

$V_{IN} = 2.5V$ to $5.5V$, $I_{OUT} = 200mA$, $EN = V_{IN}$, $C_{IN} = 4.7\mu F$, $C_{OUT} = 22\mu F$, $L_X = 10\mu H$, $T_A = 25^\circ C$.

Parameter	Conditions	Min.	Typ.	Max.	Units
Feedback (FB) Voltage			0.5		V

Electrical Characteristics for Fixed $V_{OUT} = 1.8V$ Version

$V_{IN} = 2.5V$ to $5.5V$, $I_{OUT} = 200mA$, $EN = V_{IN}$, $C_{IN} = 4.7\mu F$, $C_{OUT} = 22\mu F$, $L_X = 10\mu H$, $T_A = -40^\circ C$ to $+85^\circ C$, unless otherwise noted. Typical values are at $T_A = 25^\circ C$.

Parameter	Conditions	Min.	Typ.	Max.	Units
PFM to PWM Transition Voltage (Note 4)	$V_{IN} = 3.7V$, $T_A = 25^\circ C$, $0.1mA \leq I_{OUT} \leq 300mA$			72	mV
PFM to PWM Transition Voltage (Note 4)	$V_{IN} = 4.2V$, $T_A = 25^\circ C$, $0.1mA \leq I_{OUT} \leq 300mA$			72	mV
Output Voltage during Mode Transition (Note 5, 6)		1.7		1.93	V
Over Voltage Clamp Threshold	Incl. line, load, load transients, and temperature		1.878	1.93	V

Note:

4. Transition voltage is defined as the difference between the output voltage measured at 0.1mA (PFM mode) and 300mA (PWM mode), respectively.

5.

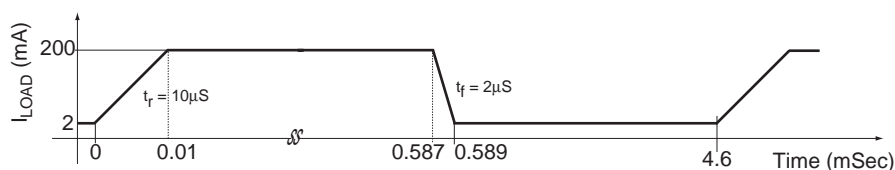

Load Transient Response Test Waveform

6. These limits also apply to any mode transition caused by any kind of load transition within specified output current range.

Typical Performance Characteristics

($T_A = 25^\circ\text{C}$, $C_{IN} = C_{OUT} = 10\mu\text{F}$, $L = 10\mu\text{H}$, $V_{OUT} = 1.8\text{V}$, unless otherwise noted.)

LINE TRANSIENT RESPONSE

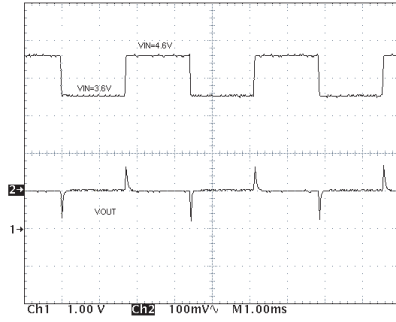

START-UP

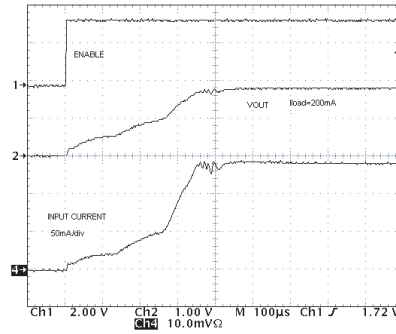

LOAD TRANSIENT RESPONSE

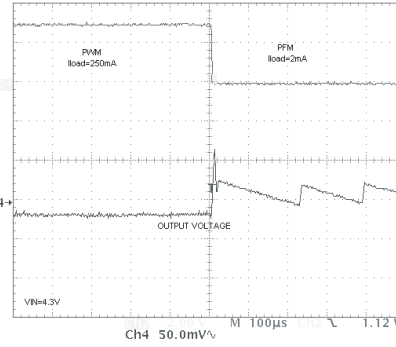
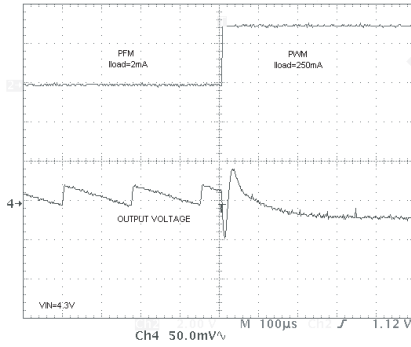

EFFICIENCY vs. LOAD CURRENT
 $V_{OUT} = 1.8\text{V}$

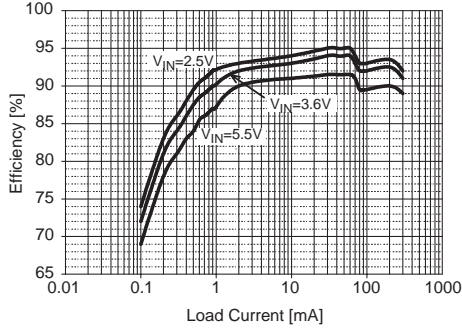

NO LOAD QUIESCENT CURRENT
vs. INPUT VOLTAGE

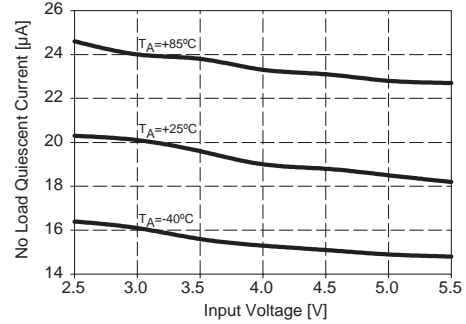

FREQUENCY vs. TEMPERATURE

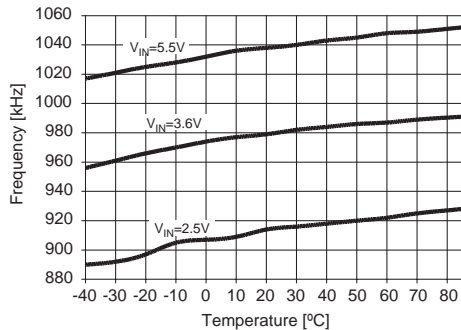

POWER SAVE (PFM) MODE OPERATION

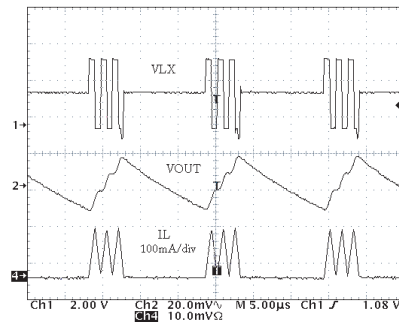

Block Diagram

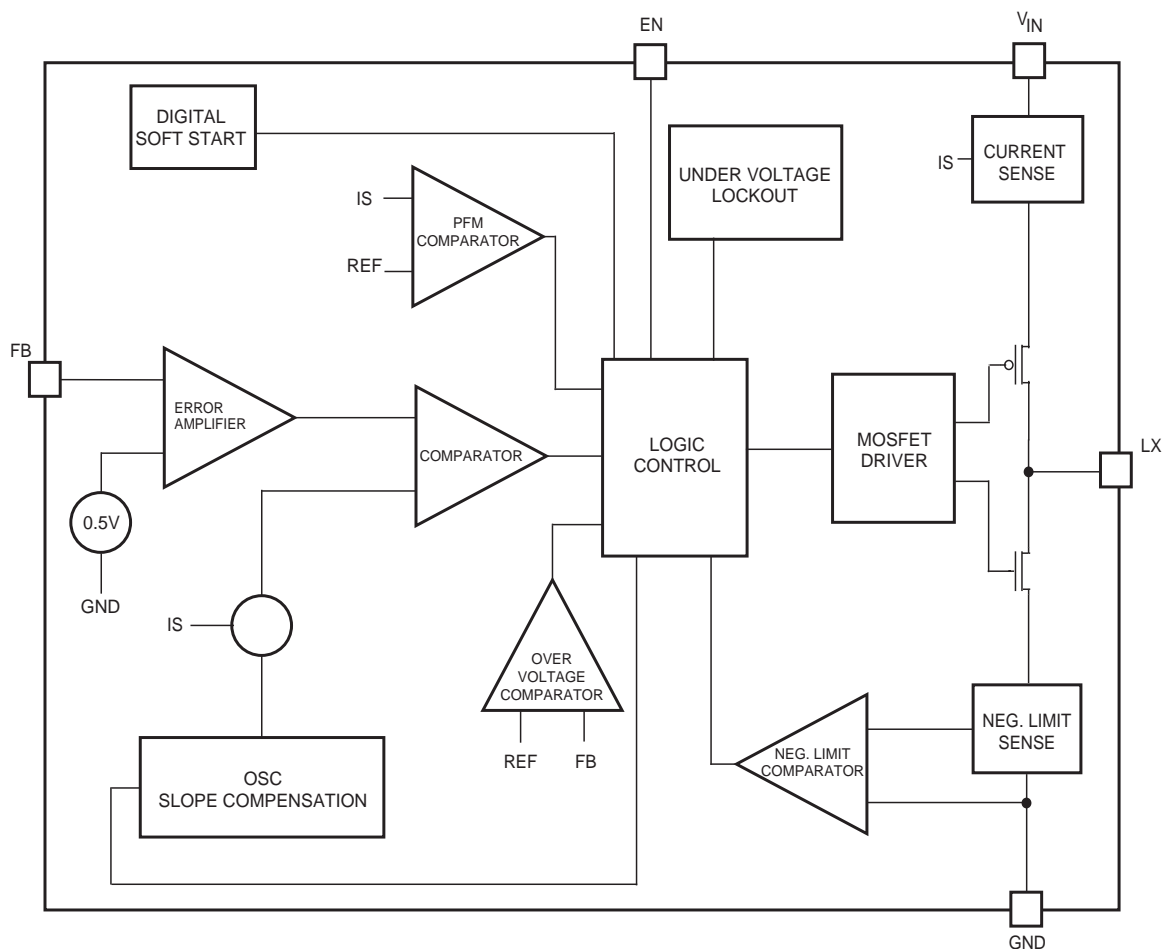

Detailed Operation Description

The FAN5307 is a step-down converter operating in a current-mode PFM/PWM architecture with a typical switching frequency of 1MHz. At moderate to heavy loads, the converter operates in pulse-width-modulation (PWM) mode. At light loads the converter enters a power-save mode (PFM pulse skipping) to keep the efficiency high.

PWM Mode

In PWM mode, the device operates at a fixed frequency of 1MHz. At the beginning of each clock cycle, the P-channel transistor is turned on. The inductor current ramps up and is monitored via an internal circuit. The P-channel switch is turned off when the sensed current causes the PWM comparator to trip when the output voltage is in regulation or when the inductor current reaches the current limit (set internally to typically 520mA). After a minimum dead time the N-channel transistor is turned on and the inductor current ramps down. As the clock cycle is completed, the N-channel switch is turned off and the next clock cycle starts.

PFM (Power Save) Mode

As the load current decreases and the peak inductor current no longer reaches the typical threshold of 80mA, the converter enters pulse-frequency-modulation (PFM) mode. In PFM mode the device operates with a variable frequency and constant peak current thus reducing the quiescent current to minimum. Consequently, the high efficiency is maintained at light loads. As soon as the output voltage falls below a threshold, set at 0.8% above the nominal value, the P-channel transistor is turned on and the inductor current ramps up. The P-channel switch turns off and the N-channel turns on as the peak inductor current is reached (typical 140mA).

The N-channel transistor is turned off before the inductor current becomes negative. At this time the P-channel is switched on again starting the next pulse. The converter continues these pulses until the high threshold (typical 1.6% above nominal value) is reached. A higher output voltage in PFM mode gives additional headroom for the voltage drop during a load transient from light to full load. The voltage overshoot during this load transient is also minimized due to active regulation during turning on the

N-channel rectifier switch. The device stays in sleep mode until the output voltage falls below the low threshold. The FAN5307 enters the PWM mode as soon as the output voltage can no longer be regulated in PFM with constant peak current.

100% Duty Cycle Operation

As the input voltage approaches the output voltage and the duty cycle exceeds the typical 95%, the converter turns the P-channel transistor continuously on. In this mode the output voltage is equal to the input voltage minus the voltage drop across the P-channel transistor:

$$V_{OUT} = V_{IN} - I_{LOAD} \times (R_{dsON} + R_L), \text{ where}$$

R_{dsON} = P-channel switch ON resistance

I_{LOAD} = Output current

R_L = Inductor DC resistance

Soft Start

The FAN5307 has an internal soft-start circuit that limits the inrush current during start-up. This prevents possible voltage drops of the input voltage and eliminates the output voltage overshoot. The soft-start is implemented as a digital circuit increasing the switch current in four steps to the P-channel current limit (520mA). Typical start-up time for a 10 μ F output capacitor and a load current of 200mA is 500 μ s.

Short-Circuit Protection

The switch peak current is limited cycle by cycle to a typical value of 520mA. In the event of a output voltage short circuit the device operates at minimum duty cycle, therefore the average input current is typically 100mA.

Application Information

Adjustable Output Voltage Version

The output voltage for the adjustable version is set by the external resistor divider, as shown below:

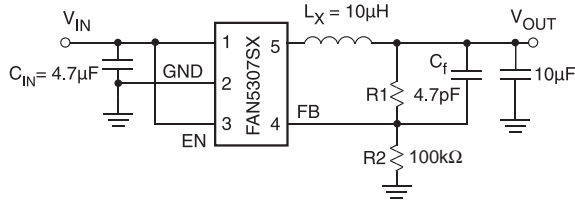

and is calculated as:

$$V_{OUT} = 0.5V \times \left[1 + \frac{R_1}{R_2} \right]$$

To reduce noise sensitivity, $R_1 + R_2$ should not exceed 1MΩ.

Inductor Selection

The inductor parameters directly related to device performances are saturation current and dc resistance. The FAN5307 operates with a typical inductor value of 10µH. The lower the dc resistance, the higher the efficiency. For saturation current, the inductor should be rated higher than the maximum load current plus half of the inductor ripple current that is calculated as follows:

$$\Delta I_L = V_{OUT} \times \frac{1 - (V_{OUT}/V_{IN})}{L \times f}$$

where:

f = Switching Frequency

L = Inductor Value

ΔI_L = Inductor Ripple Current

Inductor Value	Vendor	Part Number	Performance
10µH	Sumida	CDRH5D28-100	High Efficiency
		CDRH5D18-100	
		CDRH4D28-100	
	Murata	LQH66SN100M01L	
6.8µH	Sumida	CDRH3D16-6R8	Smallest Solution
10µH	Sumida	CDRH4D18-100	
		CR32-100	
		CR43-100	
	Murata	LQH4C100K04	

Table 1: Recommended Inductors

Input Capacitor Selection

For best performances, a low ESR input capacitor is required. A ceramic capacitor of at least 4.7µF, placed as close to the input pin of the device is recommended.

Output Capacitor Selection

The FAN5307's switching frequency of 1MHz allows the use of a low ESR ceramic capacitor with a value of 10µF to 22µF. This provides low output voltage ripple. In power save mode the output voltage ripple is independent of the output capacitor value and the ripple is determined by the internal comparator thresholds. The typical output voltage ripple at light load is 1% of the nominal output voltage.

Capacitor Value	Vendor	Part Number
4.7µF	Taiyo Yuden	JMK212BY475MG
10µF	Taiyo Yuden	JMK212BJ106MG
		JMK316BJ106KL
	TDK	C12012X5ROJ106K
		C3216X5ROJ106M
22µF	Murata	GRM32DR60J226K

Table 2: Recommended Capacitors

PCB Layout Recommendations

The inherently high peak currents and switching frequency of the power supplies require a careful PCB layout design. Therefore, use wide traces for the high current path and place the input capacitor, the inductor, and the output capacitor as close as possible to the integrated circuit terminals. For the adjustable version the resistor divider should be routed away from the inductor to avoid electromagnetic interference.

The 6-lead MLP version of the FAN5307 separates the high current ground from the reference ground, therefore it is more tolerant to the PCB layout design and shows better performance.

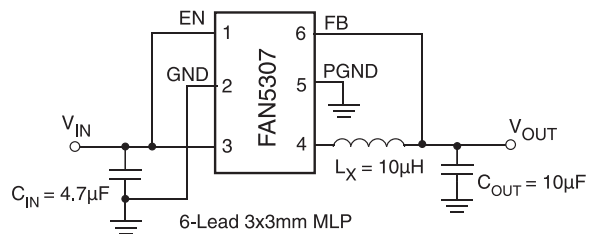

Mechanical Dimensions

6-Lead 3x3mm MLP Package

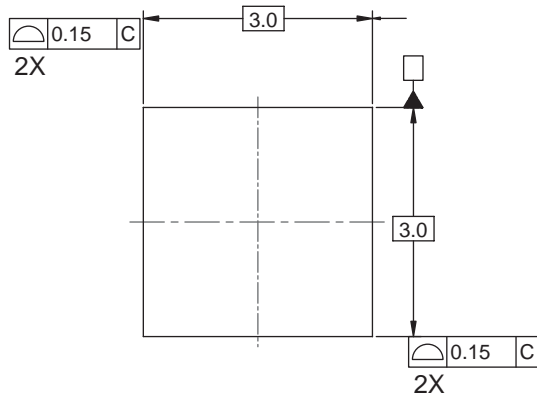

TOP VIEW

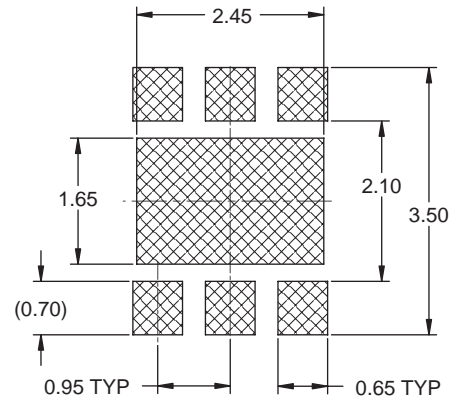

RECOMMENDED LAND PATTERN

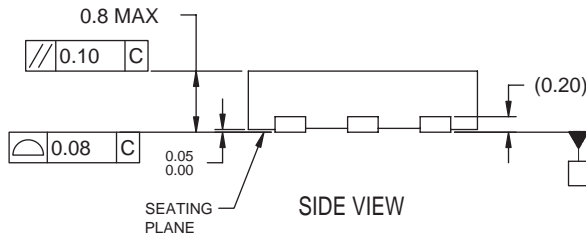

SIDE VIEW

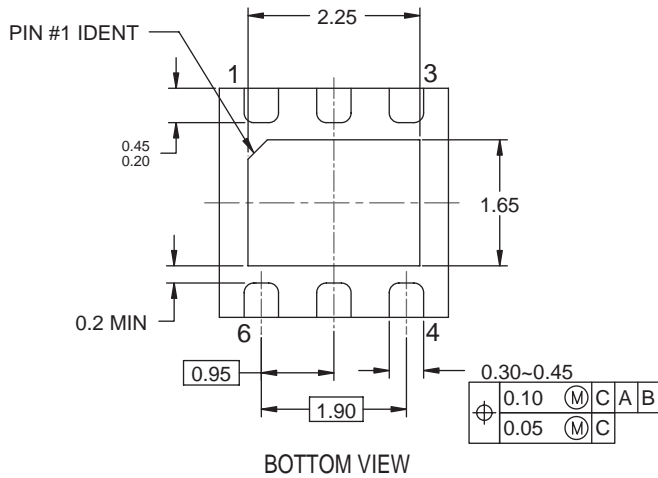

BOTTOM VIEW

NOTES:

- A. CONFORMS TO JEDEC REGISTRATION MO-229, VARIATION WEEA, DATED 11/2001
- B. DIMENSIONS ARE IN MILLIMETERS.
- C. DIMENSIONS AND TOLERANCES PER ASME Y14.5M, 1994

Mechanical Dimensions

5-Lead SOT-23 Package

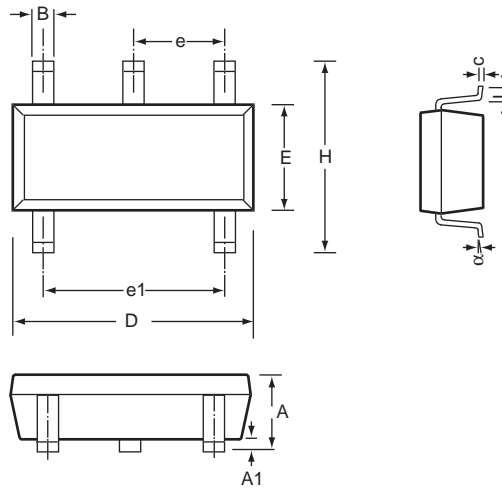

Symbol	Inches		Millimeters		Notes
	Min	Max	Min	Max	
A	.035	.057	.90	1.45	
A1	.000	.006	.00	.15	
B	.008	.020	.20	.50	
c	.003	.010	.08	.25	
D	.106	.122	2.70	3.10	
E	.059	.071	1.50	1.80	
e	.037 BSC		.95 BSC		
e1	.075 BSC		1.90 BSC		
H	.087	.126	2.20	3.20	
L	.004	.024	.10	.60	
α	0°	10°	0°	10°	

Notes:

1. Package outline exclusive of mold flash & metal burr.
2. Package outline exclusive of solder plating.
3. EIAJ Ref Number SC_74A

Ordering Information

Product Number	V _{OUT} (V)	Package Type	Order Code
FAN5307	1.8	5-Lead SOT-23 Tape and Reel	FAN5307S18X
	1.8	6-Lead 3x3mm MLP Tape and Reel	FAN5307MP18X
	1.5	5-Lead SOT-23 Tape and Reel	FAN5307S15X
	1.5	6-Lead 3x3mm MLP Tape and Reel	FAN5307MP15X
	Adjustable	5-Lead SOT-23 Tape and Reel	FAN5307SX
	Adjustable	6-Lead 3x3mm MLP Tape and Reel	FAN5307MPX

TRADEMARKS

The following are registered and unregistered trademarks Fairchild Semiconductor owns or is authorized to use and is not intended to be an exhaustive list of all such trademarks.

ACEx™	FAST®	ISOPLANAR™	PowerSaver™	SuperSOT™-6
ActiveArray™	FASTr™	LittleFET™	PowerTrench®	SuperSOT™-8
Bottomless™	FPST™	MICROCOUPLER™	QFET®	SyncFET™
Build it Now™	FRFET™	MicroFET™	QS™	TinyLogic®
CoolFET™	GlobalOptoisolator™	MicroPak™	QT Optoelectronics™	TINYOPTO™
CROSSVOLT™	GTO™	MICROWIRE™	Quiet Series™	TruTranslation™
DOMET™	HiSeC™	MSX™	RapidConfigure™	UHC™
EcoSPARK™	I ² C™	MSXPro™	RapidConnect™	UltraFET®
E ² CMOS™	i-Lo™	OCX™	μSerDes™	UniFET™
EnSigna™	ImpliedDisconnect™	OCXPro™	ScalarPump™	VCX™
FACT™	IntelliMAX™	OPTOLOGIC®	SILENT SWITCHER®	Wire™
FACT Quiet Series™		OPTOPLANAR™	SMART START™	
Across the board. Around the world.™		PACMAN™	SPM™	
The Power Franchise®		POP™	Stealth™	
Programmable Active Droop™		Power247™	SuperFET™	
		PowerEdge™	SuperSOT™-3	

DISCLAIMER

FAIRCHILD SEMICONDUCTOR RESERVES THE RIGHT TO MAKE CHANGES WITHOUT FURTHER NOTICE TO ANY PRODUCTS HEREIN TO IMPROVE RELIABILITY, FUNCTION OR DESIGN. FAIRCHILD DOES NOT ASSUME ANY LIABILITY ARISING OUT OF THE APPLICATION OR USE OF ANY PRODUCT OR CIRCUIT DESCRIBED HEREIN; NEITHER DOES IT CONVEY ANY LICENSE UNDER ITS PATENT RIGHTS, NOR THE RIGHTS OF OTHERS.

LIFE SUPPORT POLICY

FAIRCHILD'S PRODUCTS ARE NOT AUTHORIZED FOR USE AS CRITICAL COMPONENTS IN LIFE SUPPORT DEVICES OR SYSTEMS WITHOUT THE EXPRESS WRITTEN APPROVAL OF FAIRCHILD SEMICONDUCTOR CORPORATION. As used herein:

1. Life support devices or systems are devices or systems which, (a) are intended for surgical implant into the body, or (b) support or sustain life, or (c) whose failure to perform when properly used in accordance with instructions for use provided in the labeling, can be reasonably expected to result in significant injury to the user.
2. A critical component is any component of a life support device or system whose failure to perform can be reasonably expected to cause the failure of the life support device or system, or to affect its safety or effectiveness.

PRODUCT STATUS DEFINITIONS

Definition of Terms

Datasheet Identification	Product Status	Definition
Advance Information	Formative or In Design	This datasheet contains the design specifications for product development. Specifications may change in any manner without notice.
Preliminary	First Production	This datasheet contains preliminary data, and supplementary data will be published at a later date. Fairchild Semiconductor reserves the right to make changes at any time without notice in order to improve design.
No Identification Needed	Full Production	This datasheet contains final specifications. Fairchild Semiconductor reserves the right to make changes at any time without notice in order to improve design.
Obsolete	Not In Production	This datasheet contains specifications on a product that has been discontinued by Fairchild semiconductor. The datasheet is printed for reference information only.

Rev. 117