

Features

- Current-controlled Output Current Source, 3 Input Channels
- Two Selectable Outputs for Grounded Laser Diodes
- Output Current per Channel up to 250 mA
- Total Output Current to 300 mA (Minimum)
- Rise Time 1.0 ns, Fall Time 1.1 ns
- On-chip RF Oscillator
- Control of 2 Different Swings by Use of 2 external Resistors
- Oscillator Frequency Range from 200 MHz to 600 MHz
- Oscillator Swing to 100 mA
- Single 5 V Power Supply
- Common Enable/Disable Input
- TTL/CMOS Control Signals
- Small PB-free QFN16 (4 mm × 4 mm) or SSO16 Package

Applications

- DVD-ROM with CD-RW Capability (Combo Drives)
- Combo Drives with CD and DVD Writing Capability

Description

The T0806 is a laser diode driver for the operation of two different grounded laser diodes for DVD-RAM (650 nm) and CD-RW (780 nm) drives. It includes three channels for three different optical power levels which are controlled by a separate IC. The read channel generates a continuous output level whereas channels 2 and 3 are provided as write channels with very fast switching speeds. Write current pulses are enabled when a low signal is applied to the NE pins. All channels are summed together and switched to one of the two outputs IOUTA or IOUTB by the select input SELA. Each channel can contribute up to 250 mA to the total output current of up to 300 mA. A total gain of 100 is provided between each reference current input and the selected output. Although the reference inputs are current inputs, voltage control is possible by using external resistors.

An on-chip RF oscillator is provided to reduce laser mode hopping noise during read mode. Swing can be set independently for the two selectable outputs with two different resistors. Oscillation is enabled by a high signal at the ENOSC pin. Complete output current and oscillator switch-off is achieved by a low signal at the ENABLE input.

Figure 1. Block Diagram

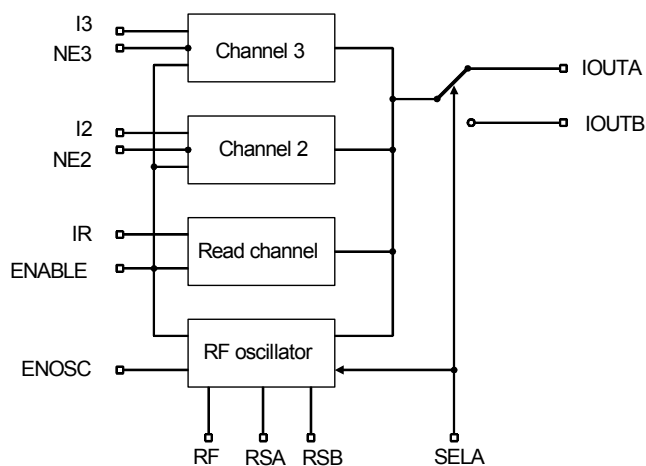

3-Channel Laser Driver with RF Oscillator and 2 Outputs

T0806

Summary

Rev. 4522ES-DVD-01/04



Pin Configuration

Figure 2. Pinning SSO16

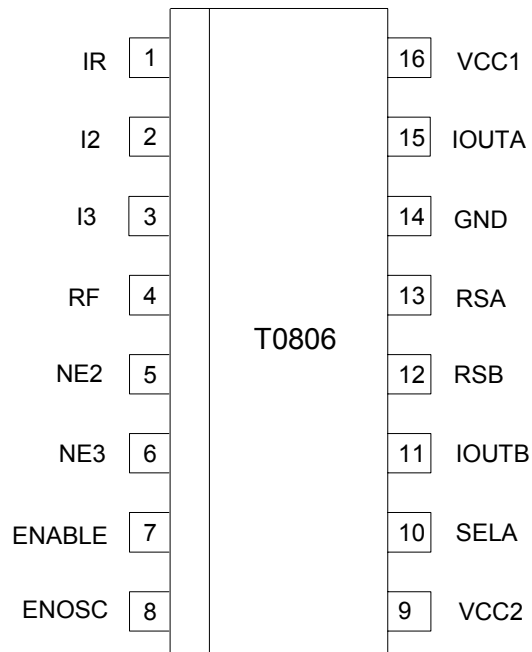

Pin Description SSO16

Pin	Symbol	Type	Function
1	IR	Analog	Input current, bias voltage approximately GND
2	I2	Analog	Input current, bias voltage approximately GND
3	I3	Analog	Input current, bias voltage approximately GND
4	RF	Analog	External resistor to GND sets oscillator frequency of oscillator A
5	NE2	Digital	Digital control of channel 2 (low active)
6	NE3	Digital	Digital control of channel 3 (low active)
7	ENABLE	Digital	Enables output current (high active)
8	ENOSC	Digital	Enables RF oscillator (high active)
9	VCC2	Supply	+5 V power supply for IOU
10	SELA	Digital	High: selects IOUTA, RSA Low: selects IOUTB, RSB
11	IOUTB	Analog	Output current source B for laser diode
12	RSB	Analog	External resistor to GND sets swing of oscillator B
13	RSA	Analog	External resistor to GND sets swing of oscillator A
14	GND	Supply	Ground
15	IOUTA	Analog	Output current source A for laser diode
16	VCC1	Supply	+5 V power supply for IOU and circuit

Figure 3. Pinning QFN16

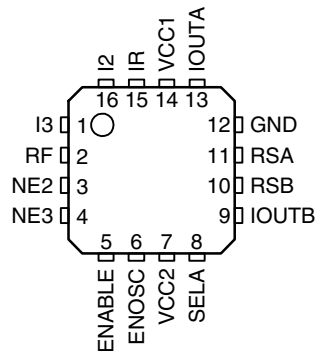

Pin Description QFN16

Pin	Symbol	Type	Function
1	I3	Analog	Input current, bias voltage approximately GND
2	RF	Analog	External resistor to GND sets oscillator frequency
3	NE2	Digital	Digital control of channel 2 (low active)
4	NE3	Digital	Digital control of channel 3 (low active)
5	ENABLE	Digital	Enables output current (high active)
6	ENOSC	Digital	Enables RF oscillator (high active)
7	VCC2	Supply	+5 V power supply for IOUT
8	SELA	Digital	High: selects IOUTA, RSA Low: selects IOUTB, RSB
9	IOUTB	Analog	Output current source B for laser diode
10	RSB	Analog	External resistor to GND sets swing of oscillator B
11	RSA	Analog	External resistor to GND sets swing of oscillator A
12	GND	Supply	Ground
13	IOUTA	Analog	Output current source A for laser diode
14	VCC1	Supply	+5 V power supply for IOUT and circuit
15	IR	Analog	Input current, bias voltage approximately GND
16	I2	Analog	Input current, bias voltage approximately GND
Paddle	GND	Supply	Ground

Absolute Maximum Ratings

Parameters	Symbol	Value	Unit
Supply voltage	V_{CC}	-0.5 to +6.0	V
Input voltage at IR, I2, I3	V_{IN1}	-0.5 to +1.0	V
Input voltage at NE2, NE3, ENOSC	V_{IN2}	-0.5 to $V_{CC} + 0.5$	V
Output voltage	V_{OUT}	-0.5 to $V_{CC} - 1$	V
Total output current	I_{OUT}	350	mA
Output current per channel	$I_{OUT (IR, I2, I3)}$	300	mA
Power dissipation	P_{MAX}	0.7 ⁽¹⁾ to 1 ⁽²⁾	W
Junction temperature	T_J	150	°C
Storage temperature range	T_{Stg}	-65 to +125	°C

Notes: 1. $R_{thJA} \leq 115$ K/W, $T_{amb} = 70^\circ\text{C}$
 2. $R_{thJA} \leq 115$ K/W, $T_{amb} = 25^\circ\text{C}$

Thermal Resistance

Parameters	Symbol	Value	Unit
Junction ambient	R_{thJA}	135	K/W

Recommended Operating Conditions

Parameters	Symbol	Value	Unit
Supply voltage range	V_{CC}	4.5 to 5.5	V
Input current	$I_{IR}/I_{I2}/I_{I3}$	< 3.0	mA
External resistor to GND to set oscillator frequency	RF	> 3	k Ω
External resistor to GND to set oscillator swing	RSA, RSB	> 1	k Ω
Operating temperature range	T_{amb}	0 to +70	°C

Ordering Information

Extended Type Number	Package	Remarks
T0806-TCQ	SSO16	Taped and reeled
T0806-PEQG	Pb-free QFN16 (4 mm × 4 mm)	Taped and reeled

Package Information

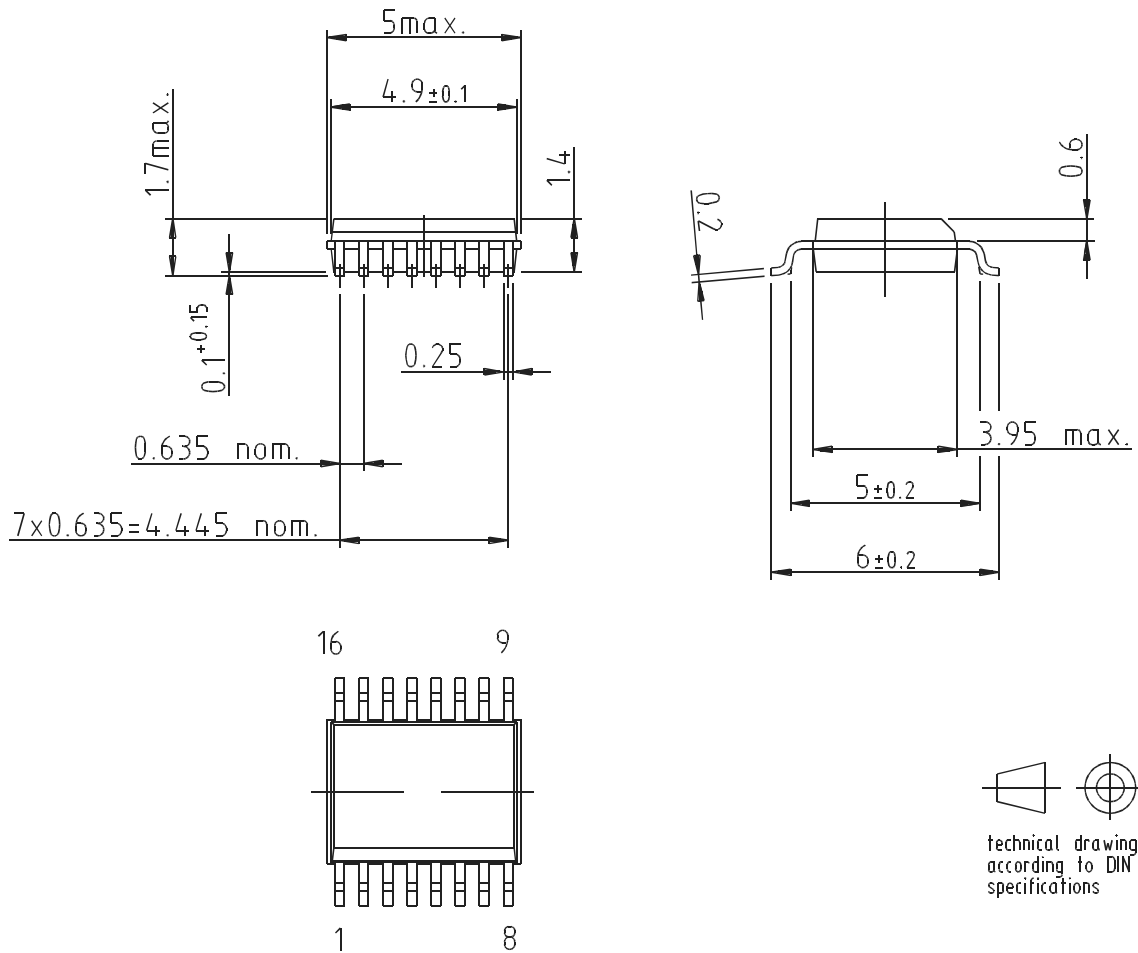

Drawing refers to following types: SS016
 Package acc. JEDEC MO 137 AB

Drawing-No.: 6.543-5060.01-4
 Issue: 2; 05.02.99

Package: QFN 16 - 4x4
 Exposed pad 2.1x2.1
 (acc. JEDEC OUTLINE No. MO-220)
 Dimensions in mm

Not indicated tolerances ± 0.05

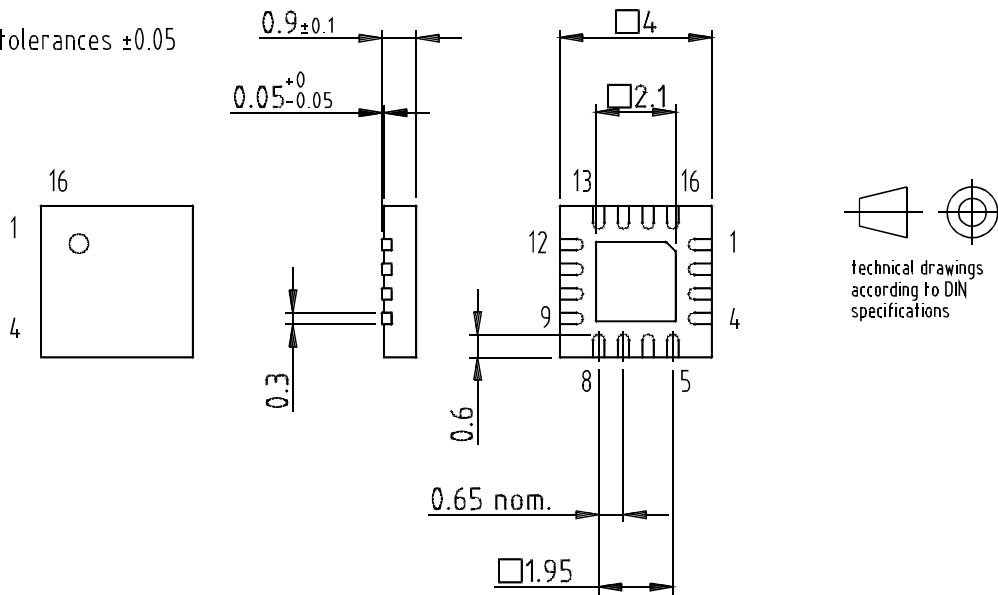

Drawing-No.: 6.543-5090.01-4
 Issue: 2; 24.01.03



Atmel Corporation

2325 Orchard Parkway
San Jose, CA 95131, USA
Tel: 1(408) 441-0311
Fax: 1(408) 487-2600

Regional Headquarters

Europe

Atmel Sarl
Route des Arsenalux 41
Case Postale 80
CH-1705 Fribourg
Switzerland
Tel: (41) 26-426-5555
Fax: (41) 26-426-5500

Asia

Room 1219
Chinachem Golden Plaza
77 Mody Road Tsimshatsui
East Kowloon
Hong Kong
Tel: (852) 2721-9778
Fax: (852) 2722-1369

Japan

9F, Tonetsu Shinkawa Bldg.
1-24-8 Shinkawa
Chuo-ku, Tokyo 104-0033
Japan
Tel: (81) 3-3523-3551
Fax: (81) 3-3523-7581

Atmel Operations

Memory

2325 Orchard Parkway
San Jose, CA 95131, USA
Tel: 1(408) 441-0311
Fax: 1(408) 436-4314

Microcontrollers

2325 Orchard Parkway
San Jose, CA 95131, USA
Tel: 1(408) 441-0311
Fax: 1(408) 436-4314

La Chantrerie
BP 70602
44306 Nantes Cedex 3, France
Tel: (33) 2-40-18-18-18
Fax: (33) 2-40-18-19-60

ASIC/ASSP/Smart Cards

Zone Industrielle
13106 Rousset Cedex, France
Tel: (33) 4-42-53-60-00
Fax: (33) 4-42-53-60-01

1150 East Cheyenne Mtn. Blvd.
Colorado Springs, CO 80906, USA
Tel: 1(719) 576-3300
Fax: 1(719) 540-1759

Scottish Enterprise Technology Park
Maxwell Building
East Kilbride G75 0QR, Scotland
Tel: (44) 1355-803-000
Fax: (44) 1355-242-743

RF/Automotive

Theresienstrasse 2
Postfach 3535
74025 Heilbronn, Germany
Tel: (49) 71-31-67-0
Fax: (49) 71-31-67-2340

1150 East Cheyenne Mtn. Blvd.
Colorado Springs, CO 80906, USA
Tel: 1(719) 576-3300
Fax: 1(719) 540-1759

Biometrics/Imaging/Hi-Rel MPU/ High Speed Converters/RF Datacom

Avenue de Rochepleine
BP 123
38521 Saint-Egreve Cedex, France
Tel: (33) 4-76-58-30-00
Fax: (33) 4-76-58-34-80

Literature Requests

www.atmel.com/literature

Disclaimer: Atmel Corporation makes no warranty for the use of its products, other than those expressly contained in the Company's standard warranty which is detailed in Atmel's Terms and Conditions located on the Company's web site. The Company assumes no responsibility for any errors which may appear in this document, reserves the right to change devices or specifications detailed herein at any time without notice, and does not make any commitment to update the information contained herein. No licenses to patents or other intellectual property of Atmel are granted by the Company in connection with the sale of Atmel products, expressly or by implication. Atmel's products are not authorized for use as critical components in life support devices or systems.

© Atmel Corporation 2004. All rights reserved.

Atmel® and combinations thereof are the registered trademarks of Atmel Corporation or its subsidiaries.

Other terms and product names may be the trademarks of others.



Printed on recycled paper.

4522ES-DVD-01/04