Features

- Current-controlled Output Current Source with 5 Input Channels
- 2 Selectable Outputs for Grounded Laser Diodes
- Output Current per Channel up to 200 mA
- Total Output Current up to 250 mA
- Rise Time 1.0 ns/Fall Time 1.1 ns
- On-chip RF Oscillator
- Control of 2 Different Frequencies and Swings by Use of 4 External Resistors
- Oscillator Frequency Range from 200 MHz to 600 MHz
- Oscillator Swing to 100 mA
- Single 5-V Power Supply
- Common Enable/Disable Input
- TTL/CMOS Control Signals
- Small SSO24 Package and QFN28 Package

Applications

- Combo Drives (DVD + CD-RW)
- DVD-RAM with CD-RW Capability
- DVD-RW with CD-RW Capability

1. Description

The T0800 is a laser diode driver for the operation of two different, grounded laser diodes for DVD-RAM (650 nm) and CD-RW (780 nm). It includes five channels for five different optical power levels which are controlled by a separate IC. The read channel generates a continuous output level. The channels 2 to 5 are provided as write channels with very fast switching speeds. When a *low* signal is applied to the NE pins, write current pulses are enabled. All channels are summed together and switched to one of the two outputs IOUTA or IOUTB by the select input SELA. Each channel can contribute up to 200 mA to the total output current of up to 250 mA. A total gain of 100 is provided between each reference current input and the selected output. Although the reference inputs are current inputs, voltage control is possible by using external resistors. An on-chip RF oscillator reduces laser mode hopping noise during read mode. Frequency and swing can be set independently for the two selectable outputs with two pairs of resistors. Oscillation is enabled by a *high* signal at the ENOSC pin. Complete output current and oscillator switch-off is achieved by a *low* signal at the ENABLE input.



5-Channel Laser Driver with RF Oscillator and 2 Outputs

T0800

Rev. 4503D-DVD-02/05



2. Pin Configuration

Figure 2-1. Pinning SSO24

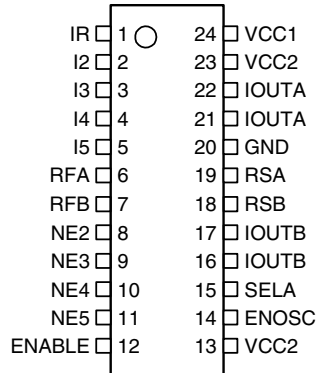

Table 2-1. Pin Description: SSO24

Pin	Symbol	Type	Function
1	IR	Analog	Input current, bias voltage approximately GND
2	I2	Analog	Input current, bias voltage approximately GND
3	I3	Analog	Input current, bias voltage approximately GND
4	I4	Analog	Input current, bias voltage approximately GND
5	I5	Analog	Input current, bias voltage approximately GND
6	RFA	Analog	External resistor to GND sets frequency of oscillator A
7	RFB	Analog	External resistor to GND sets frequency of oscillator B
8	NE2	Digital	Digital control of channel 2 (low active)
9	NE3	Digital	Digital control of channel 3 (low active)
10	NE4	Digital	Digital control of channel 4 (low active)
11	NE5	Digital	Digital control of channel 5 (low active)
12	ENABLE	Digital	Enables output current (high active)
13	VCC2	Supply	+5 V power supply for IOUT
14	ENOSC	Digital	Enables RF oscillator (high active)
15	SELA	Digital	High: selects IOUTA, RFA, RSA Low: selects IOUTB, RFB, RSB
16/17	IOUTB	Analog	Output current source B for laser diode
18	RSB	Analog	External resistor to GND sets swing of oscillator B
19	RSA	Analog	External resistor to GND sets swing of oscillator A
20	GND	Supply	Ground
21/22	IOUTA	Analog	Output current source A for laser diode
23	VCC2	Supply	+5 V power supply for IOUT
24	VCC1	Supply	+5 V power supply for circuit

Figure 2-2. Pinning QFN28

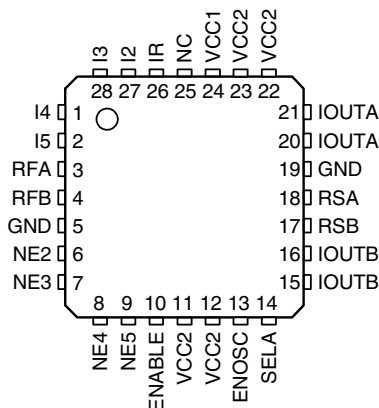
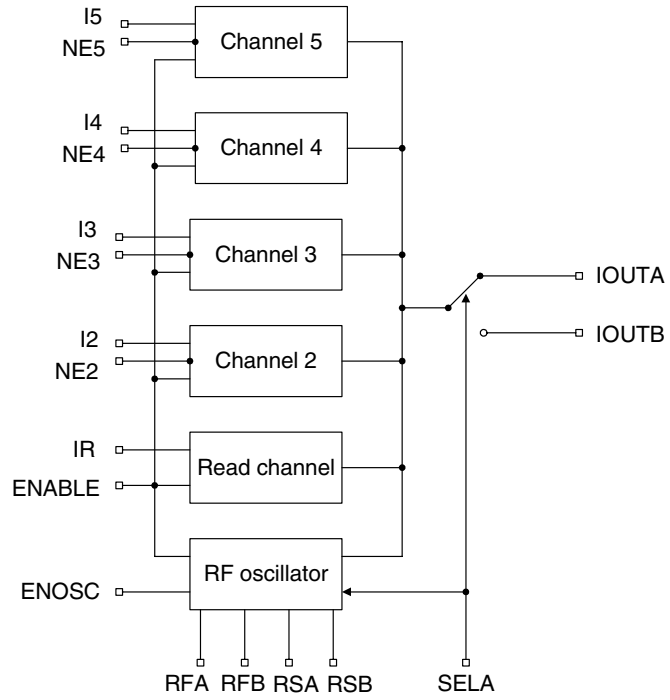

Table 2-2. Pin Description: QFN28

Pin	Symbol	Type	Function
1	I4	Analog	Input current, bias voltage approximately GND
2	I5	Analog	Input current, bias voltage approximately GND
3	RFA	Analog	External resistor to GND sets frequency of oscillator A
4	RFB	Analog	External resistor to GND sets frequency of oscillator B
5	GND	Supply	Ground
6	NE2	Digital	Digital control of channel 2 (low active)
7	NE3	Digital	Digital control of channel 3 (low active)
8	NE4	Digital	Digital control of channel 4 (low active)
9	NE5	Digital	Digital control of channel 5 (low active)
10	ENABLE	Digital	Enables output current (high active)
11, 12	VCC2	Supply	+5 V power supply IOUT
13	ENOSC	Digital	Enables RF oscillator (high active)
14	SELA	Digital	High: selects IOUTA, RFA, RSA Low: selects IOUTB, RFB, RSB
15	IOUTB	Analog	Output current source B for laser diode
16	IOUTB	Analog	Output current source B for laser diode
17	RSB	Analog	External resistor to GND sets swing of oscillator B
18	RSA	Analog	External resistor to GND sets swing of oscillator A
19	GND	Supply	Ground
20	IOUTA	Analog	Output current source A for laser diode
21	IOUTA	Analog	Output current source A for laser diode
22, 23	VCC2	Supply	+5 V power supply IOUT
24	VCC1	Supply	+5 V power supply circuit
25	NC	–	Not connected
26	IR	Analog	Input current, bias voltage approximately GND
27	I2	Analog	Input current, bias voltage approximately GND
28	I3	Analog	Input current, bias voltage approximately GND
Paddle	–	–	Should be connected with ground

Figure 2-3. Block Diagram



3. Absolute Maximum Ratings

Stresses beyond those listed under “Absolute Maximum Ratings” may cause permanent damage to the device. This is a stress rating only and functional operation of the device at these or any other conditions beyond those indicated in the operational sections of this specification is not implied. Exposure to absolute maximum rating conditions for extended periods may affect device reliability.

Parameter	Symbol	Value	Unit
Supply voltage	V_{CC}	-0.5 to +6.0	V
Input voltage at IR, I2, I3, I4, I5	V_{IN1}	-0.5 to +0.5	V
Input voltage at NE2, NE3, NE4, NE5, ENOSC	V_{IN2}	-0.5 to $V_{CC} + 0.5$	V
Output voltage	V_{OUT}	-0.5 to $V_{CC} - 1$	V
Power dissipation	P_{tot}	0.7 ⁽¹⁾ to 1 ⁽²⁾	W
Junction temperature	T_J	150	°C
Storage temperature range	T_{stg}	-65 to +125	°C

Notes: 1. $R_{thJA} \leq 115$ K/W, $T_{amb} = 70^\circ\text{C}$

2. $R_{thJA} \leq 115$ K/W, $T_{amb} = 25^\circ\text{C}$

4. Thermal Resistance

Parameter	Symbol	Value ⁽¹⁾	Unit
Junction ambient	R_{thJA}	115 (SSO24)	K/W
		35 (QFN28)	K/W

Note: 1. Measured with multi-layer test board (JEDEC standard JESD51-7)

5. Recommended Operating Conditions

Parameter	Symbol	Value	Unit
Supply voltage range	V_{CC}	4.5 to 5.5	V
Input current	$I_{IR}, I_{I2}, I_{I3}, I_{I4}, I_{I5}$	< 2.5	mA
External resistor to GND to set oscillator frequency	RFA, RFB	> 3	k Ω
External resistor to GND to set oscillator swing	RSA, RSB	> 100	Ω
Operating temperature range	T_{amb}	0 to +70	°C

6. Electrical Characteristics

$V_{CC} = 5\text{ V}$, $T_{amb} = 25^{\circ}\text{C}$, ENABLE = High, NE2 = NE3 = NE4 = NE5 = High, ENOSC = Low, unless otherwise specified

No.	Parameters	Test Conditions	Pin ⁽¹⁾	Symbol	Min.	Typ.	Max.	Unit	Type*
1	Power Supply								
1.1	Supply current, power down	ENABLE = Low, NE2 = NE3 = NE4 = NE5 = Low	11, 12, 22, 23, 24	ICC_{PD2}		0.5		mA	A
1.2	Supply current, read mode, oscillator disabled	$I_{IR} = I_{I2} = I_{I3} = I_{I4} = I_{I5} = 500\ \mu\text{A}$	11, 12, 22, 23, 24	ICC_{R1}		115		mA	A
1.3	Supply current, read mode, oscillator enabled, output A selected	$I_{IR} = I_{I2} = I_{I3} = I_{I4} = I_{I5} = 500\ \mu\text{A}$, ENOSC = High, RS = 560 Ω , RF = 7.5 k Ω , SELA = High	11, 12, 22, 23, 24	ICC_{R2}		120		mA	A
1.4	Supply current, write mode	$I_{IR} = I_{I2} = I_{I3} = I_{I4} = I_{I5} = 500\ \mu\text{A}$, NE2 = NE3 = NE4 = NE5 = Low	11, 12, 22, 23, 24	ICC_{W}		320		mA	A
1.5	Supply current, input off	$I_{IR} = I_{I2} = I_{I3} = I_{I4} = I_{I5} = 0\ \mu\text{A}$	11, 12, 22, 23, 24	ICC_{off}		18		mA	A
2	Digital Inputs								
2.1	NE2/NE3/NE4/NE5 low voltage		6, 7, 8, 9	VNE_{LO}			1.1	V	A
2.2	NE2/NE3/NE4/NE5 high voltage		6, 7, 8, 9	VNE_{HI}	2.0			V	A
2.3	SELA low voltage		14	$VSELA_{LO}$			0.5	V	A
2.4	SELA high voltage		14	$VSELA_{HI}$	2.0			V	A
2.5	ENABLE low voltage		10	VEN_{LO}			0.5	V	A
2.6	ENABLE high voltage		10	VEN_{HI}	2.0			V	A
2.7	ENOSC low voltage		13	VEO_{LO}			0.5	V	A
2.8	ENOSC high voltage		13	VEO_{HI}	2.0			V	A
3	Currents at Digital Inputs								
3.1	NE2/NE3/NE4/NE5 low current	NE = 0 V	6, 7, 8, 9	INE_{LO}	-300			μA	A
3.2	NE2/NE3/NE4/NE5 high current	NE = 5 V	6, 7, 8, 9	INE_{HI}			800	μA	A
3.3	SELA low current	SELA = 0 V	14	$ISELA_{LO}$	-45			μA	A
3.4	SELA high current	SELA = 5 V	14	$ISELA_{HI}$			150	μA	A
3.5	ENABLE low current	ENABLE = 0 V	10	IEN_{LO}	-150			μA	A
3.6	ENABLE high current	ENABLE = 5 V	10	IEN_{HI}			100	μA	A
3.7	ENOSC low current	ENOSC = 0 V	13	IEO_{LO}	-100			μA	A
3.8	ENOSC high current	ENOSC = 5 V	13	IEO_{HI}			800	μA	A

*) Type means: A = 100% tested, B = 100% correlation tested, C = Characterized on samples, D = Design parameter

Note: 1. Related to QFN28 Package

7. Electrical Characteristics: Laser Amplifier

$V_{CC} = 5\text{ V}$, $T_{amb} = 25^\circ\text{C}$, ENABLE = High, unless otherwise specified

No.	Parameters	Test Conditions	Pin	Symbol	Min.	Typ.	Max.	Unit	Type*
4	Outputs IOUTA and IOUTB								
4.1	Best fit current gain	Any channel ⁽¹⁾	15, 16, 20, 21	GAIN	90	100	130	mA/mA	A
4.2	Best fit current offset	Any channel ⁽¹⁾	15, 16, 20, 21	IOS	-8		+4	mA	A
4.3	Output current linearity	Any channel ⁽¹⁾	15, 16, 20, 21	ILIN	-3		+3	%	A
4.5	Output current per channel	Output is sourcing	15, 16, 20, 21	I_{OUTR}	200			mA	A
4.6	Total output current		15, 16, 20, 21	I_{OUT}	250			mA	A
4.7	I_{IN} input impedance	R_{IN} is to GND	1, 2, 26, 27, 28	R_{IN}	170	220	270	Ω	A
4.8	NE threshold	Temperature stabilized	6, 7, 8, 9	V_{TH}		1.68		V	C
4.9	Output off current 1	ENABLE = Low	15, 16, 20, 21	I_{OFF1}			1	mA	A
4.10	Output off current 2	NE2 = NE3 = NE4 = NE5 = High	15, 16, 20, 21	I_{OFF2}			1	mA	A
4.11	Output off current 3	NE2 = NE3 = NE4 = NE5 = Low, $I_{IR} = I_{I2} = I_{I3} = I_{I4} = I_{I5} =$ $0\ \mu\text{A}$	15, 16, 20, 21	I_{OFF3}			5	mA	A
4.12	I_{OUT} supply sensitivity, read mode	$I_{OUT} = 40\ \text{mA}$, $V_{CC} = 5\ \text{V} \pm 10\%$, read-only	15, 16, 20, 21	VSE_R	-5		1	%V	A
4.13	I_{OUT} supply sensitivity, write mode	$I_{OUT} = 80\ \text{mA}$, 40 mA read + 40 mA write, $V_{CC} = 5\ \text{V} \pm 10\%$	15, 16, 20, 21	VSE_W	-6		0	%V	A
4.14	I_{OUT} current output noise	$I_{OUT} = 40\ \text{mA}$, ENOSC = Low	15, 16, 20, 21	INO_O		3		nA/ rt-Hz	C
4.15	I_{OUT} temperature sensitivity, read mode	$I_{OUT} = 40\ \text{mA}$, read only	15, 16, 20, 21	TSE_R		-100		ppm/ $^\circ\text{C}$	C
4.16	I_{OUT} temperature sensitivity, write mode	$I_{OUT} = 80\ \text{mA}$, 40 mA read + 40 mA write	15, 16, 20, 21	TSE_W		-300		ppm/ $^\circ\text{C}$	C

*) Type means: A = 100% tested, B = 100% correlation tested, C = Characterized on samples, D = Design parameter

Note: 1. Linearity of the amplifier is calculated using a best fit method at three operating points of I_{OUT} at 20 mA, 40 mA, and 60 mA, $I_{OUT} = (I_{IN} \times \text{GAIN}) + I_{OS}$

8. Electrical Characteristics

$V_{CC} = 5\text{ V}$, $I_{OUT} = 40\text{ mA}$ DC with 40-mA pulse, $T_{amb} = 25^\circ\text{C}$, unless otherwise specified

No.	Parameters	Test Conditions	Pin	Symbol	Min.	Typ.	Max.	Unit	Type*
5	Outputs IOUTA and IOUTB, AC Performance								
5.1	Write rise time	$I_{OUT} = 40\text{ mA}$ (read) +40 mA (10%-90%) ⁽¹⁾	15, 16, 20, 21	t_{RISE}		1.0	3.0	ns	C
5.2	Write fall time	$I_{OUT} = 40\text{ mA}$ (read) +40 mA (10%-90%) ⁽¹⁾	15, 16, 20, 21	t_{FALL}		1.1	3.0	ns	C
5.3	Output current overshoot	$I_{OUT} = 40\text{ mA}$ (read) + 40 mA ⁽¹⁾	15, 16, 20, 21	OS		5		%	C
5.4	I_{OUT} ON prop delay	NE 50% High-Low to I_{OUT} at 50% of final value	15, 16, 20, 21	t_{ON}		2.0		ns	C
5.5	I_{OFF} OFF prop delay	NE 50% Low-High to I_{OUT} at 50% of final value	15, 16, 20, 21	t_{OFF}		2.0		ns	C
5.6	Disable time	ENABLE 50% High-Low to I_{OUT} at 50% of final value	15, 16, 20, 21	t_{DIS}		20		ns	C
5.7	Enable time	ENABLE 50% Low-High to I_{OUT} at 50% of final value	15, 16, 20, 21	t_{EN}		20		ns	C
5.8	Disable time oscillator	ENOSC 50% Low-High to I_{OUT} at 50% of final value	15, 16, 20, 21	T_{DISO}		4		ns	C
5.9	Enable time oscillator	ENOSC 50% High-Low to I_{OUT} at 50% of final value	15, 16, 20, 21	T_{ENO}		2		ns	C
5.10	SELA delay	SELA Low-High 50% to I_{OUT} at 50% of final value	15, 16, 20, 21	T_{SAH}		TBD		ns	C
5.11	SELA delay	SELA High-Low 50% to I_{OUT} at 50% of final value	15, 16, 20, 21	T_{SAL}		TBD		ns	C
5.12	Amplifier bandwidth	$I_{OUT} = 50\text{ mA}$, all channels, -3 dB value	15, 16, 20, 21	BW_{LCA}		20		MHz	C
6	Oscillator								
6.1	Oscillator frequency	RF = 4.7 k Ω	15, 16, 20, 21	F_{OSC}	380	470	560	MHz	A
6.2	Oscillator temperature coefficient	RF = 4.7 k Ω	15, 16, 20, 21	TC_{OSC}		-150		ppm/ $^\circ\text{C}$	C
6.3	Disable time oscillator	ENOSC 50% High-Low to I_{OUT} at 10%/90% of final value	15, 16, 20, 21	T_{DISO}		4		ns	C
6.4	Enable time oscillator	ENOSC 50% Low-High to I_{OUT} at 10%/90% of final value	15, 16, 20, 21	T_{ENO}		2		ns	C

*) Type means: A = 100% tested, B = 100% correlation tested, C = Characterized on samples, D = Design parameter

9. Application Information Oscillator

Figure 9-1. Frequency versus Resistor RFA and RFB (RS = 525 Ω)

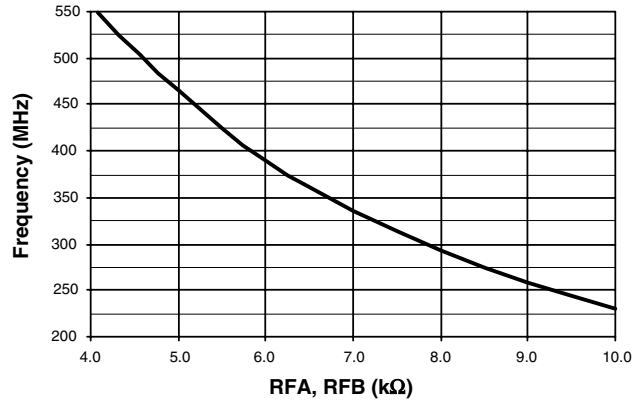

Figure 9-2. Swing versus Resistor RSA and RSB (RF = 7.82 kΩ)

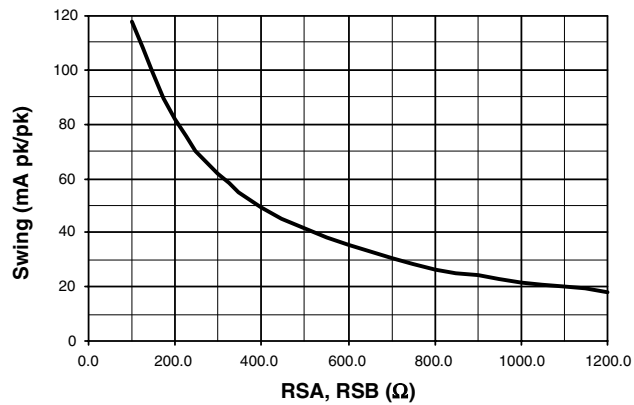

Figure 9-3. Frequency Dependency of Swing

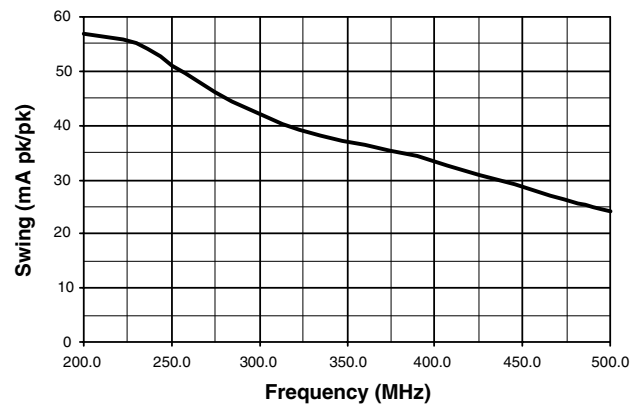

Figure 9-4. Transfer Characteristic of all Channels (Gain = 111)

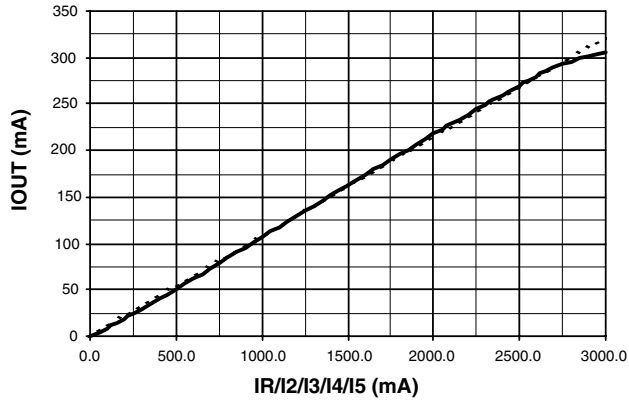

Figure 9-5. Output Characteristic (Voltage Compliance) $R(I_{OUT}) = 5.8 \Omega$

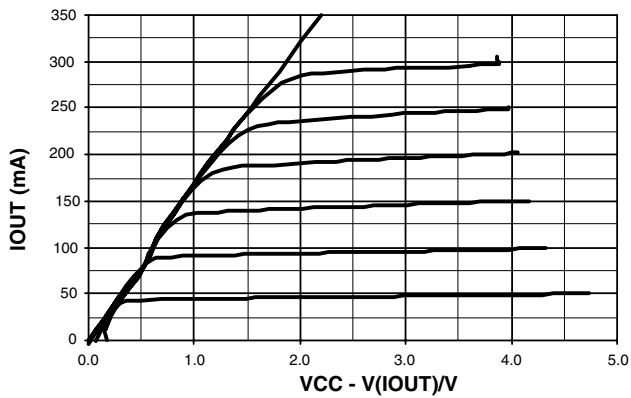

Figure 9-6. Output Pulse, Read: 50 mA, Write: 250 mA pk-pk

Tek Run: 4.00GS/s Average

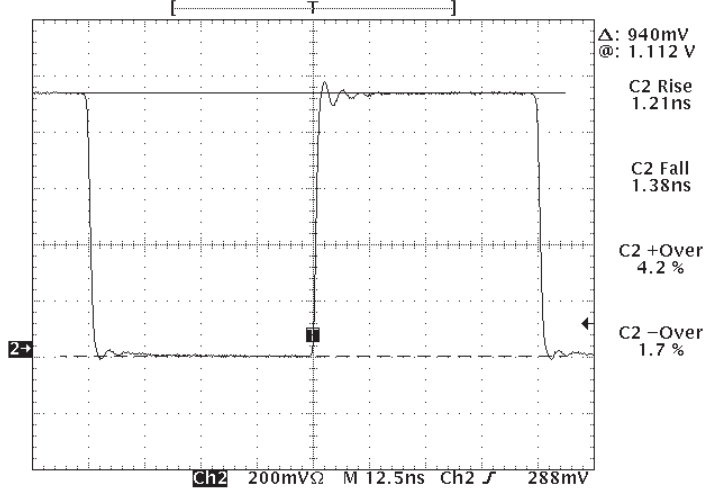

Figure 9-7. Timing Diagram of IOU

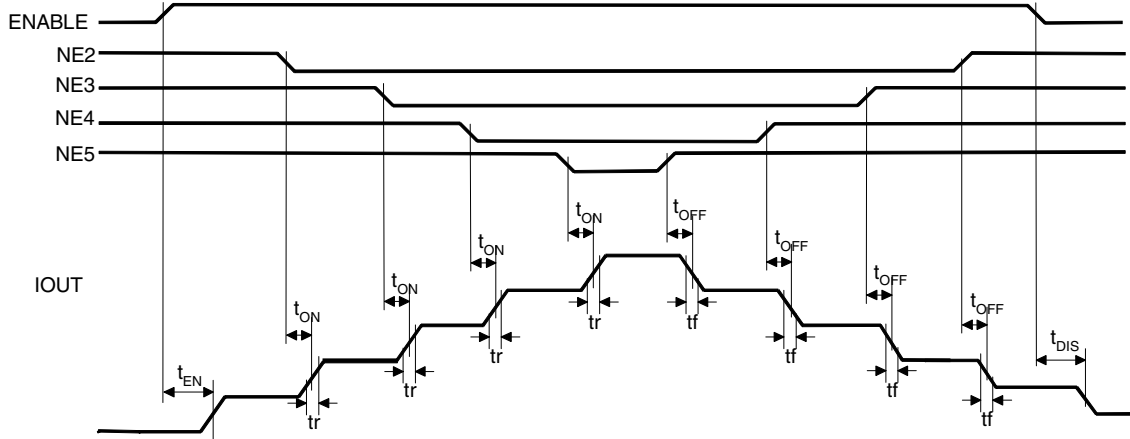
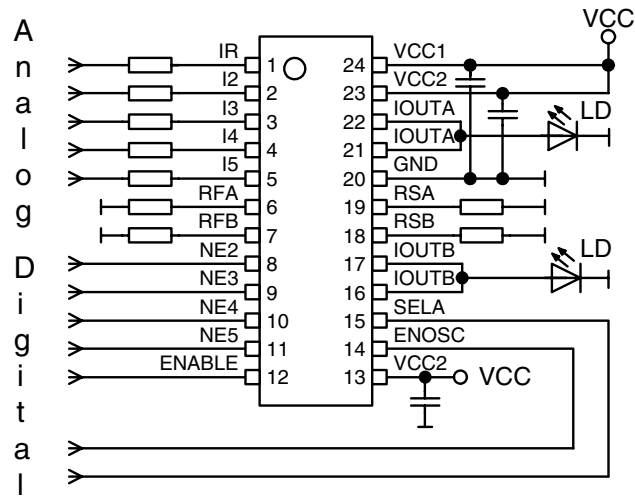

Figure 9-8. Application Circuit



10. Ordering Information

Extended Type Number	Package	Remarks
T0800-TNQ	SSO24	Taped and reeled
T0800-PJQ	QFN28	Taped and reeled

11. Package Information

Package SSO24
Dimensions in mm

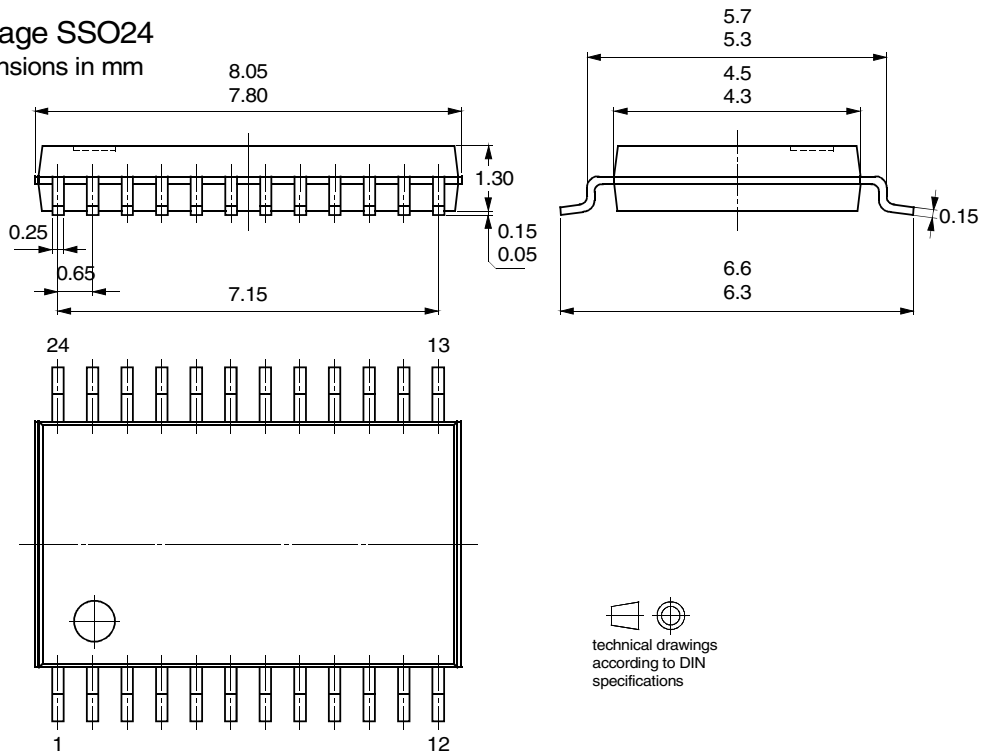

technical drawings
according to DIN
specifications

Package: QFN 28 - 5x5
 Exposed pad 3.1x3.1
 (acc. JEDEC OUTLINE No. MO-220)
 Dimensions in mm

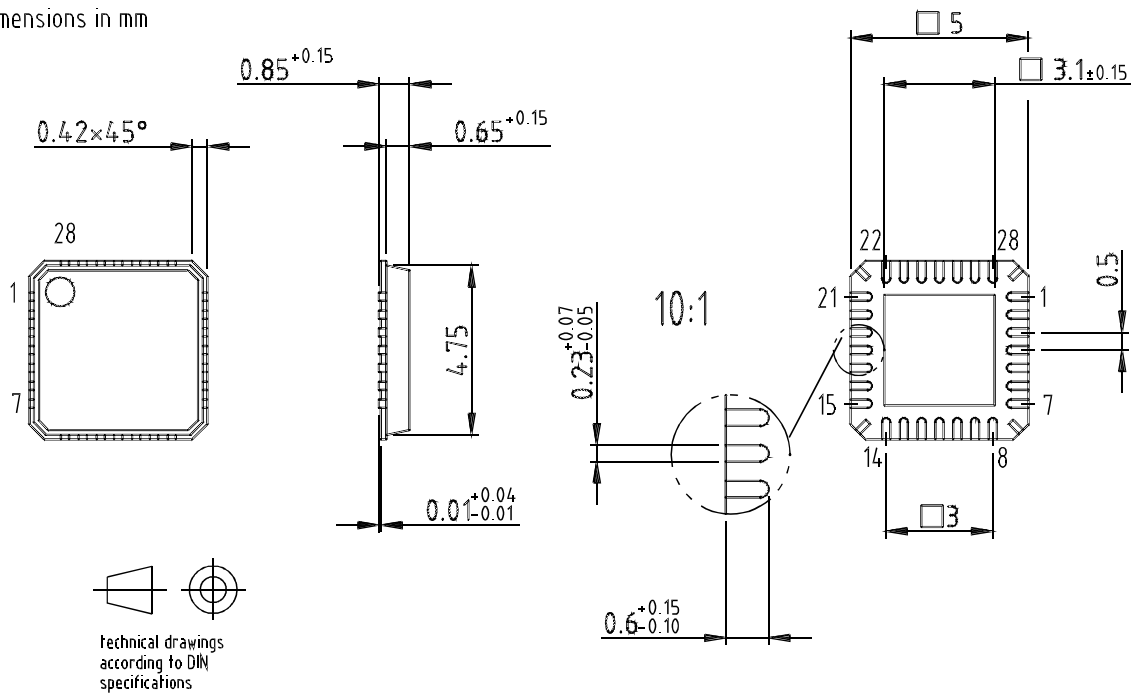

Drawing-No: 6.543-5081.01-4
 Issue: 3; 24.01.03



Atmel Corporation

2325 Orchard Parkway
San Jose, CA 95131, USA
Tel: 1(408) 441-0311
Fax: 1(408) 487-2600

Regional Headquarters

Europe

Atmel Sarl
Route des Arsenaux 41
Case Postale 80
CH-1705 Fribourg
Switzerland
Tel: (41) 26-426-5555
Fax: (41) 26-426-5500

Asia

Room 1219
Chinachem Golden Plaza
77 Mody Road Tsimshatsui
East Kowloon
Hong Kong
Tel: (852) 2721-9778
Fax: (852) 2722-1369

Japan

9F, Tonetsu Shinkawa Bldg.
1-24-8 Shinkawa
Chuo-ku, Tokyo 104-0033
Japan
Tel: (81) 3-3523-3551
Fax: (81) 3-3523-7581

Atmel Operations

Memory

2325 Orchard Parkway
San Jose, CA 95131, USA
Tel: 1(408) 441-0311
Fax: 1(408) 436-4314

Microcontrollers

2325 Orchard Parkway
San Jose, CA 95131, USA
Tel: 1(408) 441-0311
Fax: 1(408) 436-4314

La Chantreterie
BP 70602
44306 Nantes Cedex 3, France
Tel: (33) 2-40-18-18-18
Fax: (33) 2-40-18-19-60

ASIC/ASSP/Smart Cards

Zone Industrielle
13106 Rousset Cedex, France
Tel: (33) 4-42-53-60-00
Fax: (33) 4-42-53-60-01

1150 East Cheyenne Mtn. Blvd.
Colorado Springs, CO 80906, USA
Tel: 1(719) 576-3300
Fax: 1(719) 540-1759

Scottish Enterprise Technology Park
Maxwell Building
East Kilbride G75 0QR, Scotland
Tel: (44) 1355-803-000
Fax: (44) 1355-242-743

RF/Automotive

Theresienstrasse 2
Postfach 3535
74025 Heilbronn, Germany
Tel: (49) 71-31-67-0
Fax: (49) 71-31-67-2340

1150 East Cheyenne Mtn. Blvd.
Colorado Springs, CO 80906, USA
Tel: 1(719) 576-3300
Fax: 1(719) 540-1759

Biometrics/Imaging/Hi-Rel MPU/ High Speed Converters/RF Datacom

Avenue de Rochepleine
BP 123
38521 Saint-Egreve Cedex, France
Tel: (33) 4-76-58-30-00
Fax: (33) 4-76-58-34-80

Literature Requests

www.atmel.com/literature

Disclaimer: The information in this document is provided in connection with Atmel products. No license, express or implied, by estoppel or otherwise, to any intellectual property right is granted by this document or in connection with the sale of Atmel products. **EXCEPT AS SET FORTH IN ATMEL'S TERMS AND CONDITIONS OF SALE LOCATED ON ATMEL'S WEB SITE, ATMEL ASSUMES NO LIABILITY WHATSOEVER AND DISCLAIMS ANY EXPRESS, IMPLIED OR STATUTORY WARRANTY RELATING TO ITS PRODUCTS INCLUDING, BUT NOT LIMITED TO, THE IMPLIED WARRANTY OF MERCHANTABILITY, FITNESS FOR A PARTICULAR PURPOSE, OR NON-INFRINGEMENT. IN NO EVENT SHALL ATMEL BE LIABLE FOR ANY DIRECT, INDIRECT, CONSEQUENTIAL, PUNITIVE, SPECIAL OR INCIDENTAL DAMAGES (INCLUDING, WITHOUT LIMITATION, DAMAGES FOR LOSS OF PROFITS, BUSINESS INTERRUPTION, OR LOSS OF INFORMATION) ARISING OUT OF THE USE OR INABILITY TO USE THIS DOCUMENT, EVEN IF ATMEL HAS BEEN ADVISED OF THE POSSIBILITY OF SUCH DAMAGES.** Atmel makes no representations or warranties with respect to the accuracy or completeness of the contents of this document and reserves the right to make changes to specifications and product descriptions at any time without notice. Atmel does not make any commitment to update the information contained herein. Atmel's products are not intended, authorized, or warranted for use as components in applications intended to support or sustain life.

© Atmel Corporation 2005. All rights reserved. Atmel®, logo and combinations thereof, and others, are registered trademarks, and Everywhere You AreSM and others are the trademarks of Atmel Corporation or its subsidiaries. Other terms and product names may be trademarks of others.



Printed on recycled paper.

4503D-DVD-02/05