

System LED Drivers for Mobile phones

Chopper type for Flash



BD6062GU

No.11041EBT13

●Description

The BD6062GU is 1A Flash LED Driver ICs that can drive 1LED. It is possible to select how to control, 2wired control mode (Direct Control Mode) or 3wired mode (Register Control Mode). The BD6062GU has original Timer function in 3wired mode and easily set pre-flash timer and flash timer.

●Features

- 1) 400mA ~ 800mA selectable in Flash mode (Register Control Mode)
- 2) 50 ~ 200mA Torch mode (Register Control Mode)
- 3) 800mA in Flash mode (Direct control Mode)
- 4) 200mA in Torch mode (Direct control Mode)
- 5) Maximum current of LED is 1A in both Flash and Torch mode
- 6) 3Wired Mode and Direct control Mode selectable
- 7) In 3Wired Mode, Pre-Flash Timer and Flash Timer controllable
- 8) In 3Wired Mode, Flash current and Torch current is controllable
- 9) Over voltage protection
- 10) CSP 23pin Small and Thin package

●Applications

Flash and torch of camera for mobile phone

●Line up matrix

Parameter	BD6062GU
Input voltage	2.7 ~ 5.5V
Switching Frequency	480 ~ 720kHz
Maximum LED Current	1A
Package	VCSP85H2

●Absolute maximum ratings (Ta=25°C)

Parameter	Symbol	Ratings	Unit	Condition
Maximum applied voltage	VMAX	7	V	VBAT, VIO
Power dissipation	Pd	1100 * ¹	mW	
Operating temperature range	Topr	-30~+85	°C	
Storage temperature range	Tstg	-55~+150	°C	

*1 50mm × 58mm × 1.75mm At glass epoxy board mounting. When it's used by more than Ta=25°C, it's reduced by 11mW/°C

●Recommended operating range (Ta= -30°C ~ +85°C)

Parameter	Symbol	Ratings			Unit	Condition
		Min.	Typ.	Max.		
Power Supply Voltage	VDD	2.7	3.6	5.5	V	* ²
IO Supply Voltage	VIO	1.62	1.8	3.3	V	* ²

*2 VBAT ≥ VIO

●Electrical characteristics

(Unless otherwise noted, Ta = +25°C, VBAT=3.6V, VIO=1.8V)

Parameter	Symbol	Limits			Units	Condition
		Min.	Typ.	Max.		
[Logic control terminal (IFMODE='L', 3wired control mode)]						
Low threshold voltage1	VthL1	-	-	VIO* 0.25	V	
High threshold voltage1	VthH1	VIO* 0.75	-	-	V	
High level Input current1	linH1	-	-	5	μA	Vin=VIO
Low level Input current1	linL1	-5	-	-	μA	Vin=0V
[Logic control terminal (IFMODE='H', Direct control mode)]						
Low threshold voltage2	VthL2	-	-	0.4	V	
High threshold voltage2	VthH2	1.4	-	-	V	
High level Input current2	linH2	-	18.3	30	μA	FLASH=TORCH=5.5V
Low level Input current2	linL2	-2	-0.1	-	μA	FLASH=TORCH=0V
[Others]						
Input voltage range	Vin	3.1	-	5.5	V	VBAT input range
Quiescent Current	Iq	-	5	10	μA	Torch=Flash= OFF
Current Consumption	Idd1	-	1.8	2.5	mA	VFB=1.0V, Vin=3.6V, Torch mode
Inductor current limit	Icoil	1.5	2.0	2.5	A	Vin=3.6V *3
Switching frequency	fSW	480	600	720	kHz	
SW ON resistance	Ron	-	0.07	0.15	Ω	lin=200mA
Duty cycle limit	Duty	60	65	-	%	VFB=0V
Output voltage range	Vo	-	-	5.4	V	
Over voltage limit	Ovl	5.4	5.5	5.6	V	VFB=0V
Start up time	Ts		0.5	1.0	ms	0mA to 200mA(Torch)
R torch terminal voltage 1	Vrt1	45	50	55	mV	Itorch[1:0]=00 (50mA)
R torch terminal voltage 2	Vrt2	90	100	110	mV	Itorch[1:0]=01 (100mA)
R torch terminal voltage 3	Vrt3	135	150	165	mV	Itorch[1:0]=10 (150mA)
R torch terminal voltage 4	Vrt4	180	200	220	mV	Itorch[1:0]=11 (200mA)
R flash terminal voltage 1	Vrf1	43	48	53	mV	Iflash[1:0]=00 (400mA)
R flash terminal voltage 2	Vrf2	54	60	66	mV	Iflash[1:0]=01 (500mA)
R flash terminal voltage 3	Vrf3	65	72	79	mV	Iflash[1:0]=10 (600mA)
R flash terminal voltage 4	Vrf4	86	96	106	mV	Iflash[1:0]=11 (800mA)

*3 This parameter is tested with dc measurement.

●Electrical characteristic curves (Reference data)

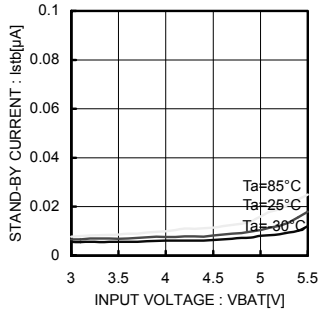

Fig.1 Quiescent current consumption (VBAT)

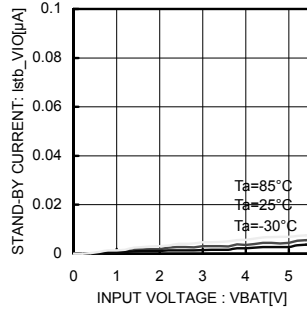

Fig.2 Quiescent current consumption (VIO)

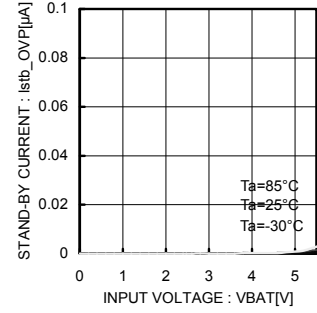

Fig.3 Quiescent current consumption (OVP)

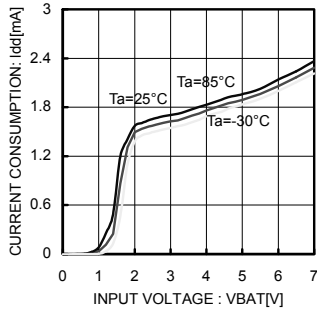

Fig.4 Current consumption(VBAT)

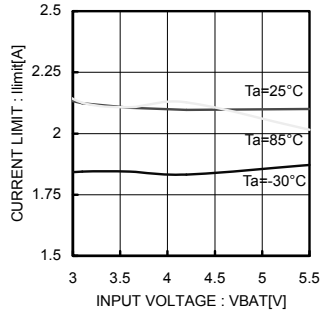

Fig.5 Over-Current Limiter

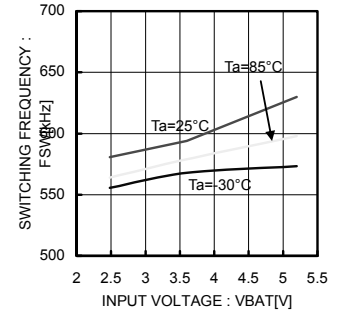

Fig.6 Switching Frequency

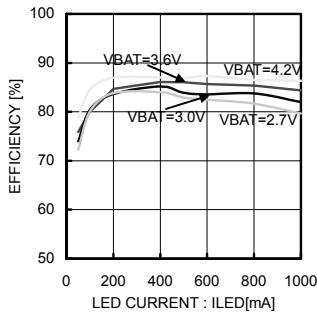

Fig.7 1A appl. Efficiency (Ta = 25°C)

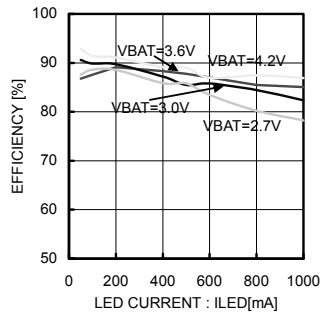

Fig.8 1A appl. Efficiency (Ta = 85°C)

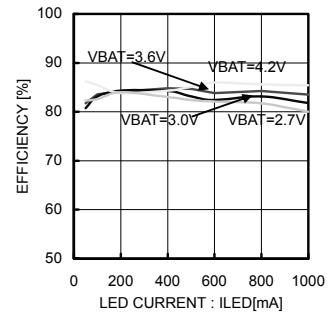

Fig.9 1A appl. Efficiency (Ta = -30°C)

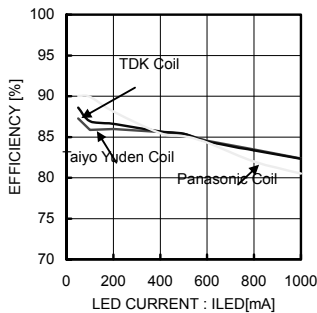

Fig.10 Each Coil Efficiency (Ta = 25°C, VBAT = 3.6V)

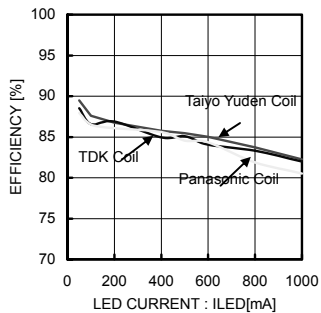

Fig.11 Each Coil Efficiency (Ta = 85°C, VBAT = 3.6V)

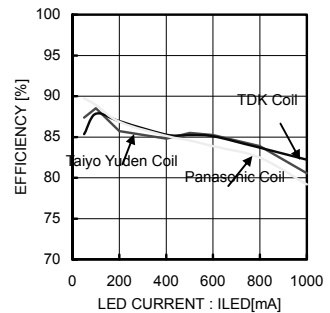

Fig.12 Each Coil Efficiency (Ta = -30°C, VBAT = 3.6V)

●Electrical characteristic curves (Reference data) – Continued

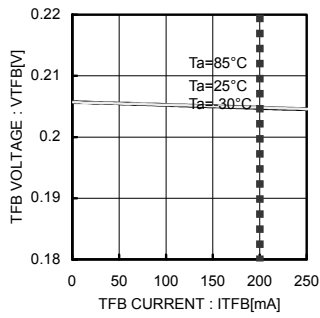

Fig.13 TORCH Load Regulation (VBAT = 5.5V)

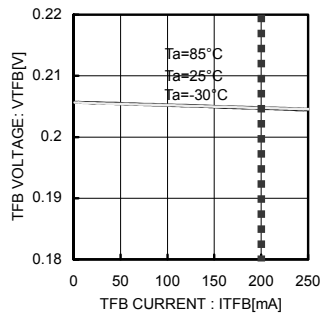

Fig.14 TORCH Load Regulation (VBAT = 3.6V)

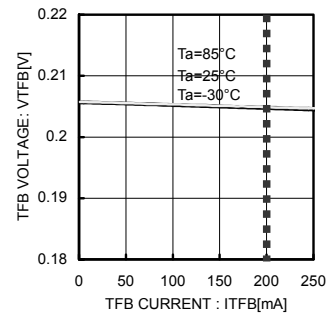

Fig.15 TORCH Load Regulation (VBAT = 2.7V)

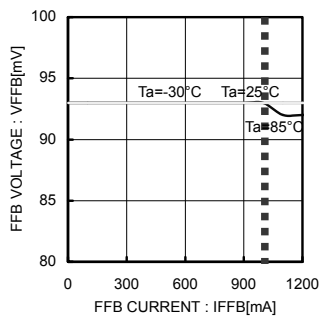

Fig.16 FLASH Load Regulation (VBAT = 5.5V)

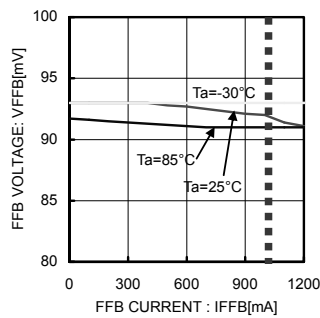

Fig.17 FLASH Load Regulation (VBAT = 3.6V)

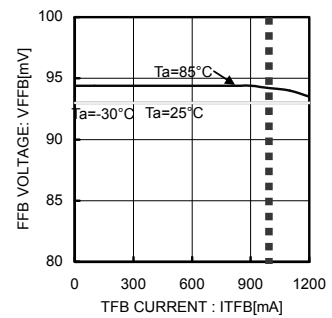

Fig.18 FLASH Load Regulation (VBAT = 2.7V)

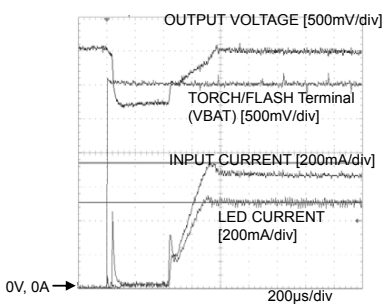

Fig.19 500mA Input rush current (VBAT=3.0V)

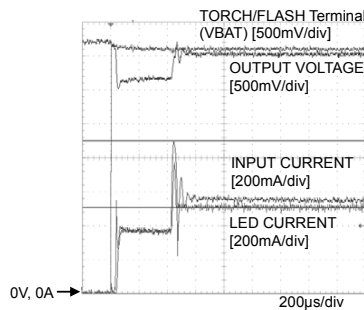

Fig.20 500mA Input rush current (VBAT=3.6V)

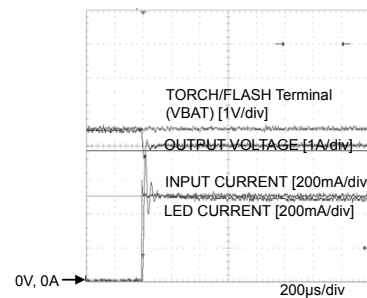

Fig.21 500mA Input rush current (VBAT=4.5V)

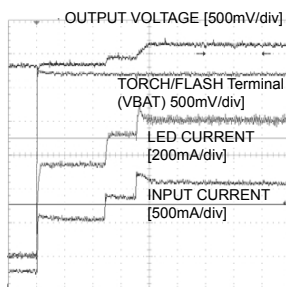

Fig.22 1A Input rush current (200mA → 1A)

●Block diagram and pin configuration

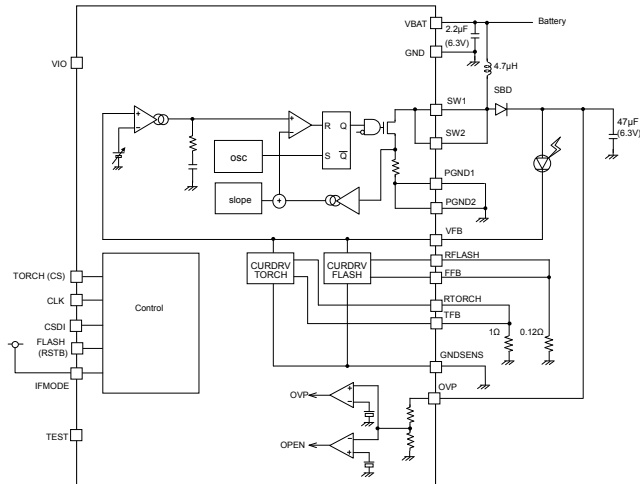

Fig.23 1A application Block diagram of Direct control Mode

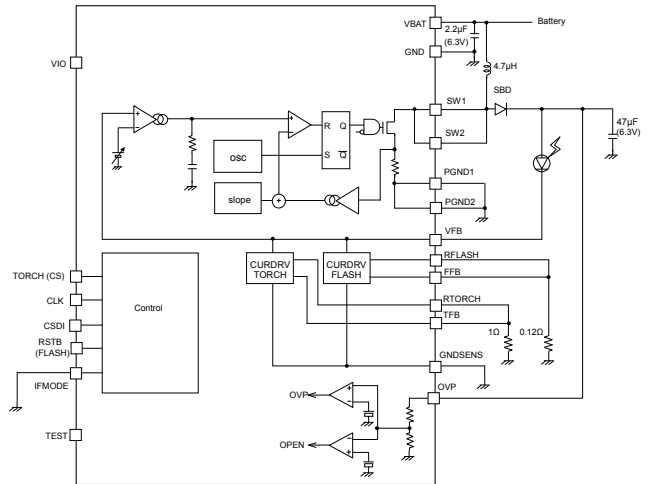

Fig.24 1A application Block diagram of 3wired control Mode

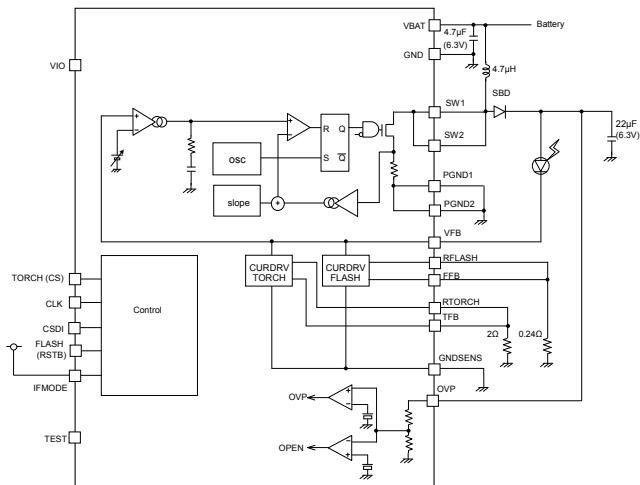

Fig.25 500mA application Block diagram of Direct control Mode

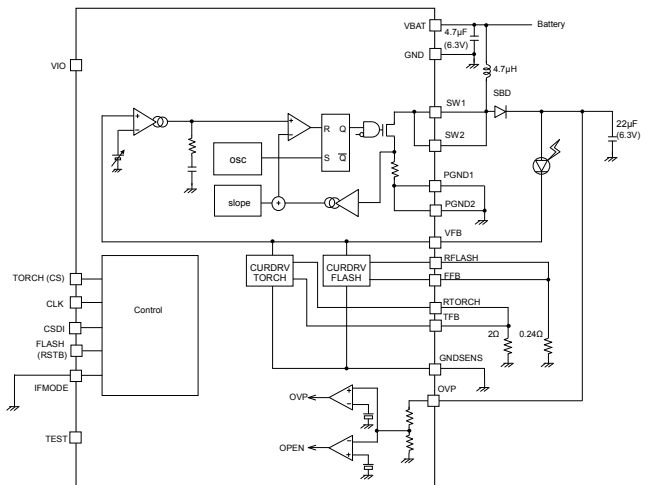

Fig.26 500mA application Block diagram of 3wired control Mode

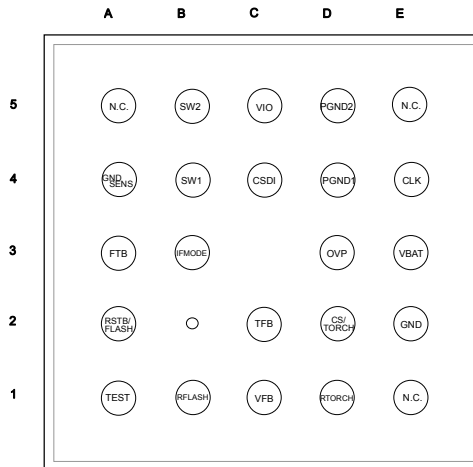

Fig.27 pin location diagram (TOP VIEW)

●Pin assignment table

No.	Pin Name	In/ Out	Functions
A1	TEST	In	Digital test select pin
A2	RSTB/FLASH	In	Reset ("L":Reset) (IFMODE='0') FLASH enable ("H") (IFMODE='1')
A3	FFB	In	Flash current driver feedback pin
A4	GNDSENS	In	Sense GND pin for current driver
A5	N.C	-	open
B1	RFLASH	Out	Flash current adjustment resistor pin
B3	IFMODE	In	Interface mode select
B4	SW1	In	Switching terminal 1
B5	SW2	In	Switching terminal 2
C1	VFB	In	Voltage feedback pin
C2	TFB	In	Torch current driver feedback pin
C4	CSDI	In	Data input
C5	VIO	-	I/O power supply pin
D1	RTORCH	Out	Torch current adjustment resistor pin
D2	CS/TORCH	In	Chip select (IFMODE='0') TORCH enable (IFMODE='1')
D3	OVP	In	Boost voltage feedback input pin
D4	PGND1	-	Power GND pin 1
D5	PGND2	-	Power GND pin 2
E1	N.C	-	Open
E2	GND	-	GND pin
E3	VBAT	-	Battery power supply pin
E4	CLK	In	Clock
E5	N.C	-	Open

Total : 23 Pin

●Description of function

1) CPU I/F

The Control Serial I/F provides access to Flash LED driver control registers.

Write timing show following timing chart.

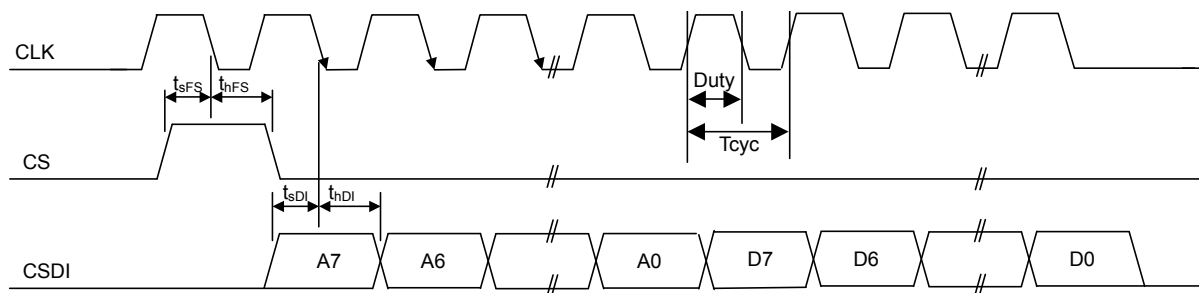

Fig.28 Control Serial Port Timing

Control Serial Port Specifications

Parameter	Symbol	Limits			Unit	Condition
		Min.	Typ.	Max.		
CS Input Setup	t_{sFS}	50	-	-	ns	
CS Input Hold	t_{hFS}	50	-	-	ns	
CSDI Input Setup	t_{sDI}	50	-	-	ns	
CSDI Input Hold	t_{hDI}	50	-	-	ns	
Clock Cycle Time	T_{cyc}	133.3	-	-	ns	MAX 7.5 MHz
Duty Ratio	Duty	40	50	60	%	

Performance specifications are guaranteed, but not production tested.

2) Register map

Symbol	Address [7:0]	D[7]	D[6]	D[5]	D[4]	D[3]	D[2]	D[1]	D[0]
ENA	01 (H)	-	-	-	-	-	-	Flash	Torch
TIME	02 (H)	-	Tmode	Tdelay2	Tdelay1	Tdelay0	Tflash2	Tflash1	Tflash0
CURR	03 (H)	-	-	-	CLMT	lflash1	lflash0	ltorch1	ltorch0
TEST	04 (H)	-	-	-	-	Test3	Test2	Test1	Test0
TEST2	05 (H)	-	-	-	TEST24	TEST23	TEST22	TEST21	TEST20

*Note: Write access is prohibited in TEST and TEST2 registers.

Address"00(H)", Enable control

2-1) Enable control

Flash	Torch	Output	Default
0	0	off	*
0	1	ltorch	
1	0	lflash	
1	1	ltorch + lflash	

*When IFMODE=H, each enable signal are controlled by CPU directly from Pin.

Address"01(H)", Timer mode setting and Flash timer period control

2-2) Timer mode control

Tmode	Timer mode	Default
0	disable	
1	enable	*

2-3) Flash delay timer setting

Tdelay[2:0]	tFlash1	Default
000	0ms	*
001	5ms	
010	10ms	
011	15ms	
100	20ms	
101	25ms	
110	30ms	
111	35ms	

tFLASH1 : Flash on delay timer

It control the period from flash enable to

light up.

2-4) Flash ON timer setting

Tflash[2:0]	TFlash2	Default
000	50ms	*
001	100ms	
010	150ms	
011	200ms	
100	400ms	
101	600ms	
110	800ms	
111	1000ms	

tFLASH2 : Flash on timer

It control the period from light up to off.

*When IFMODE=H, it does not use timer function. Flash period is controlled by CPU directly.

Address"02(H)", Flash and Torch current setting

2-5) Output current setting for the Torch current driver

Itorch[1:0]	Output current	Default	IFMODE=H
00	50mA	*	
01	100mA		
10	150mA		
11	200mA		*

2-6) Output current setting for the Flash current driver

Iflash[1:0]	Output current	Default	IFMODE=H
00	400mA	*	
01	500mA		
10	600mA		
11	800mA		*

2-7) Over power protection enable

CLMT	Current Limit	Default	IFMODE=H
0	disable	*	*
1	enable		

It depends on battery or external components condition, internal power consumption will be large at flash action and there is a possibility that it will over Power dissipation of IC.
 BD6062GU can limit drive current on over power condition, and protect to over Power dissipation.
 When this mode is enable, BD6062GU limit maximum current automatically as below.

Torch Max200mA → Max200mA
 Flash Max800mA → 400mA

3) Power Control

BD6062GU can be controlled the status of activation using Enable control resistor.

4) LED drive current (Torch Mode)

The LED current is decided by the voltage of RTORCH terminal. (Rtorch=1.0Ω)
 ILED is given as follows,

$$I_{LED} = I(\text{Torch Current Driver}) = V_{RTORCH} / 1.0(\Omega)$$

VRTORCH=0.05V, Rtorch =1.0Ω, ILED=50mA : Itorch [1:0] = 00
 VRTORCH=0.2V, Rtorch =1.0Ω, ILED=200mA : Itorch [1:0] = 11

VRTORCH is controlled 0.05V~0.2V by resistor setting.

5) LED drive current (Flash Mode)

The LED current is decided by the voltage of RFLASH terminal and RTORCH terminal.
 (Rflash=0.12Ω, Rtorch=1.0Ω)

ILED is given as follows,

$$I_{LED} = I(\text{Flash Current Driver}) + I(\text{Torch Current Driver}) = V_{RFLASH} / 0.12(\Omega) + V_{RTORCH} / 1.0(\Omega)$$

VRFLASH=0.096V, Rflash =0.12Ω, Itorch[1:0]=11
 VRTORCH=0.2V, Rtorch =1.0Ω, Iflash[1:0]=11 } ILED=200mA+800mA=1000mA

VRFLASH is controlled 0.048V~0.096V by resistor setting.

6) Basic function

i) Register control interface(3wired) mode (timer enable)

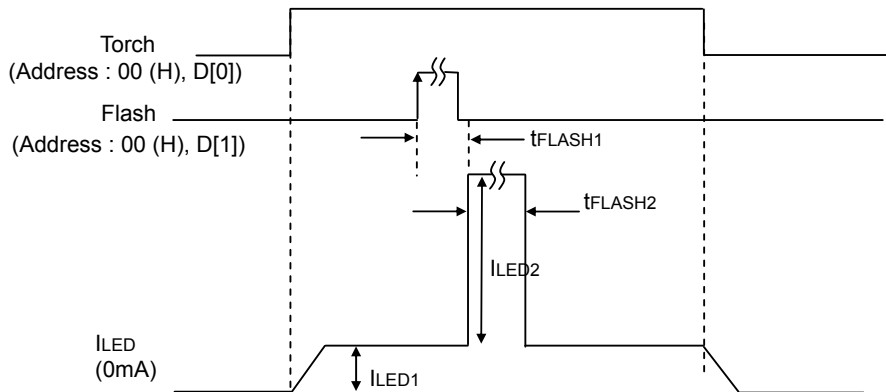

ILED1 : Torch Current Driver
 ILED2 : Torch Current Driver
 tFLASH1,2 : Flash time is controlled by timer resistor setting.

Fig.29 3wired mode Torch and Flash Timing (Timer enable)

ii) Register control interface(3wired) mode (timer disable)

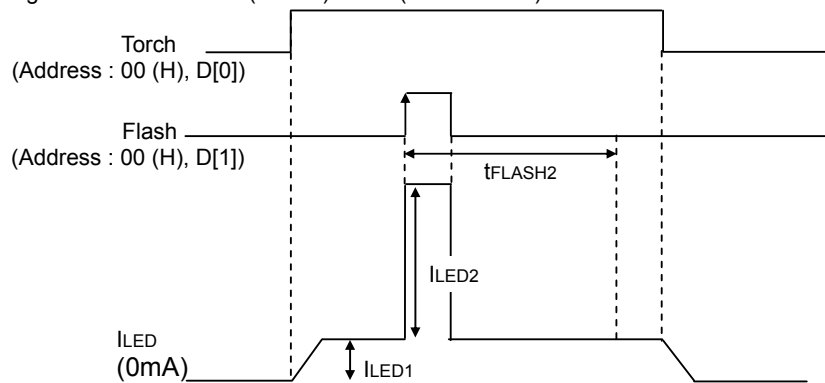

ILED1 : Torch Current Driver
 ILED2 : Flash Current Driver
 tFLASH2 : Flash period protect

Fig.30 3wired mode Torch and Flash Timing (Timer disable)

If flash period is over tFLASH2 setting, flash current driver will enable to turn off.
 Protect time is controlled by flash ON timer resistor setting.

iii) Direct control interface mode

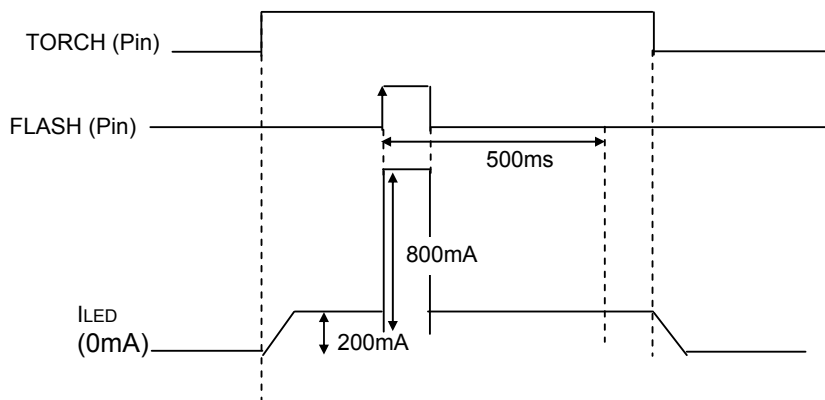

There is LED protect function in this mode.
 Flash period is over 500ms, then this mode turn off flash.

Fig.31 Direct Control mode Torch and Flash Timing

iv) The voltage of VFB is as follows, (in DC/DC on)

- Torch mode → 350mV
- Flash mode → 350mV

7) Soft start

BD6062GU has soft start function.

Soft start function will prevent the big peak current from IC and coil.

The detail of soft start is as follows.

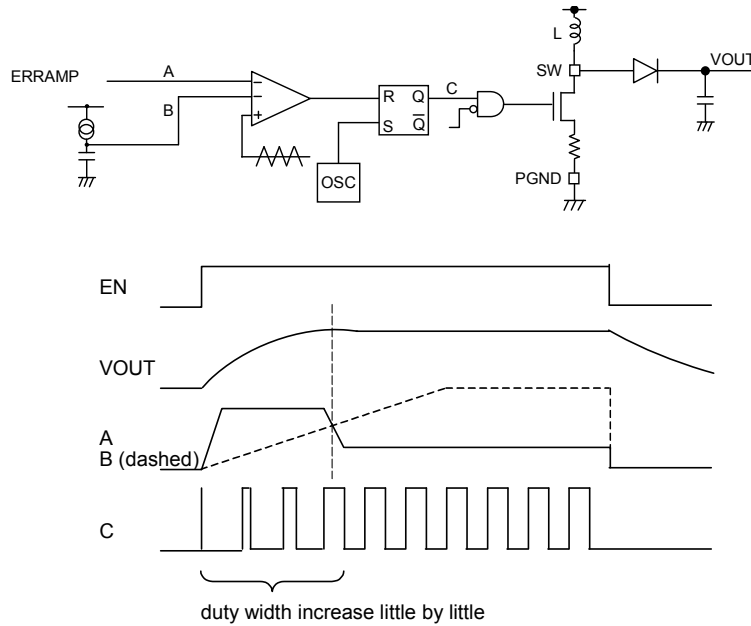

Fig.32 Soft start Diagram and Timing

8) Soft Current Limiter

BD6062GU has Soft Current Limiter function.

Soft current limiter function will change the value of current gradually.

It has four steps. And the steps are as follows;

4Step of soft current limiter

Action	Start	2nd step	3rd step	4th step	Normal
Time	0~500us	500~700us	700~800us	800~900us	900us~
Current Limit (DC)	0A* always	0.5A	1A	1.5A	2A
Current Limit "H (peak)	1.125A	1.75A	2.375A	3.0A	3.625A
Current Limit "L (peak)	0.675A	1.05A	1.425A	1.8A	2.175A

Peak current of BD6062GU depends on only soft current limiter.

Switching frequency or VBAT voltage does not affect Peak current of BD6062GU.

9) Thermal shut down

BD6062GU has a thermal shut down function.

It works above 175°C, and while, IC will change the status from active to inactive.

When the temperature will be under 175°C, IC will return to normal operation.

10) Safety functions

10-1) Over voltage detect function (OVP)

When OVP become more than 5.5V, IC stop the switching.

When OVP become less than detect voltage, the status of switching will restart.

10-2) Open detect function (ODF)

When OVP pin is not connected any components, IC will stop the switching.

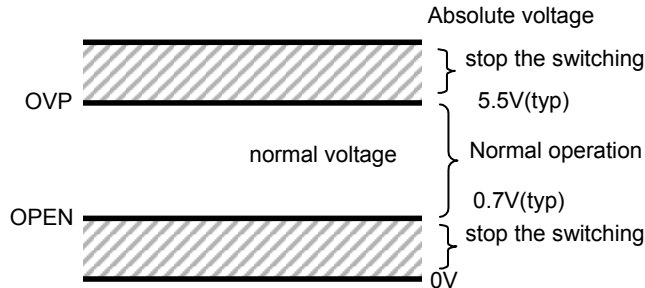

Fig.33 Safety Voltage range

●Selection of external parts

Recommended external parts are as shown below.

When to use other parts than these, select the following equivalent parts.

Coil(L1)

Value	Vendor	Parts number	Size			DCR (ohm)
			X	Y	Z	
4.7μH	Taiyou Yuden	NR4018T4R7M	4.0	4.0	1.8	0.09
4.7μH	TDK	VLF3012AT-4R7MR74*	2.6	2.8	1.2	0.13

*) for under 500mA application

Capacitor

Value	Vendor	Parts number	Size		
			X	Y	Z
Cin					
2.2μF	MURATA	GRM188B30J225KE	1.6	0.8	0.8
Cout					
47μF	MURATA	GRM32EB31A476KE20	3.2	3.2	2.5
22μF	MURATA	GRM21BB30J226ME38B*	2.0	1.25	1.25

*) for under 500mA application

Resistance

Value	Vendor	Parts number	Size			class
			X	Y	Z	
Rflash						
0.12ohm	ROHM	MCR10EZHFLR120	2.0	1.25	0.55	±1%
0.24ohm	ROHM	MCR10EZHFLR240*	2.0	1.25	0.55	±1%
Rtorch						
1.0ohm	ROHM	MCR10EZHFL1R00	2.0	1.25	0.55	±1%
2.0ohm	ROHM	MCR10EZHFL2R00*	2.0	1.25	0.55	±1%

*) for under 500mA application

Shotkey Diode(D1)

VF	Vendor	Parts number	Size		
			X	Y	Z
0.43V	ROHM	RB160M-30	2.6	1.6	0.80

●Recommended layout pattern

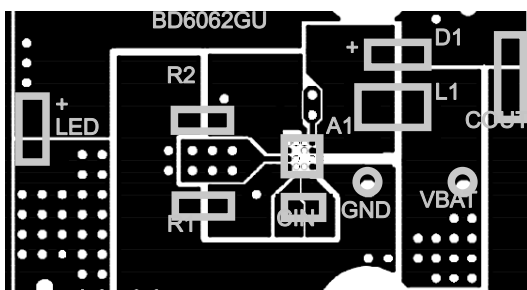

Fig.34 Frontal surface (TOP VIEW)

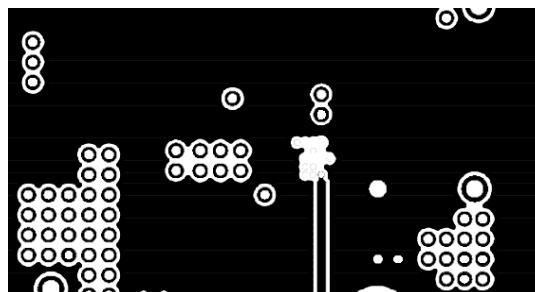

Fig.35 Middle surface1 (TOP VIEW)

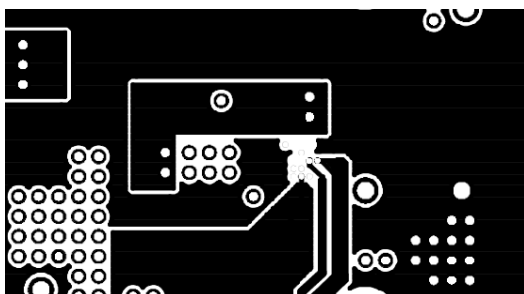

Fig.36 Middle surface2 (TOP VIEW)

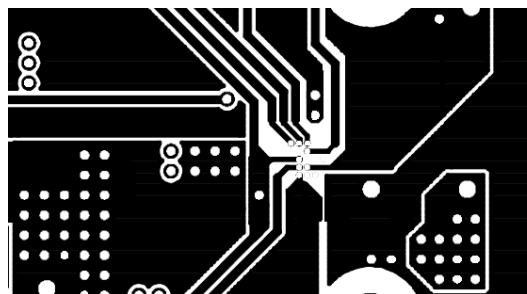

Fig.37 Rear surface (TOP VIEW)

●Notes for use

- (1) Absolute Maximum Ratings
An excess in the absolute maximum ratings, such as supply voltage, temperature range of operating conditions, etc., can break down devices, thus making impossible to identify breaking mode such as a short circuit or an open circuit. If any special mode exceeding the absolute maximum ratings is assumed, consideration should be given to take physical safety measures including the use of fuses, etc.
- (2) Operating conditions
These conditions represent a range within which characteristics can be provided approximately as expected. The electrical characteristics are guaranteed under the conditions of each parameter.
- (3) Reverse connection of power supply connector
The reverse connection of power supply connector can break down ICs. Take protective measures against the breakdown due to the reverse connection, such as mounting an external diode between the power supply and the IC's power supply terminal.
- (4) Power supply line
Design PCB pattern to provide low impedance for the wiring between the power supply and the GND lines. In this regard, for the digital block power supply and the analog block power supply, even though these power supplies has the same level of potential, separate the power supply pattern for the digital block from that for the analog block, thus suppressing the diffraction of digital noises to the analog block power supply resulting from impedance common to the wiring patterns. For the GND line, give consideration to design the patterns in a similar manner.
Furthermore, for all power supply terminals to ICs, mount a capacitor between the power supply and the GND terminal. At the same time, in order to use an electrolytic capacitor, thoroughly check to be sure the characteristics of the capacitor to be used present no problem including the occurrence of capacity dropout at a low temperature, thus determining the constant.
- (5) GND voltage
Make setting of the potential of the GND terminal so that it will be maintained at the minimum in any operating state. Furthermore, check to be sure no terminals are at a potential lower than the GND voltage including an actual electric transient.

- (6) Short circuit between terminals and erroneous mounting
In order to mount ICs on a set PCB, pay thorough attention to the direction and offset of the ICs. Erroneous mounting can break down the ICs. Furthermore, if a short circuit occurs due to foreign matters entering between terminals or between the terminal and the power supply or the GND terminal, the ICs can break down.
- (7) Operation in strong electromagnetic field
Be noted that using ICs in the strong electromagnetic field can malfunction them.
- (8) Inspection with set PCB
On the inspection with the set PCB, if a capacitor is connected to a low-impedance IC terminal, the IC can suffer stress. Therefore, be sure to discharge from the set PCB by each process. Furthermore, in order to mount or dismount the set PCB to/from the jig for the inspection process, be sure to turn OFF the power supply and then mount the set PCB to the jig. After the completion of the inspection, be sure to turn OFF the power supply and then dismount it from the jig. In addition, for protection against static electricity, establish a ground for the assembly process and pay thorough attention to the transportation and the storage of the set PCB.
- (9) Input terminals
In terms of the construction of IC, parasitic elements are inevitably formed in relation to potential. The operation of the parasitic element can cause interference with circuit operation, thus resulting in a malfunction and then breakdown of the input terminal. Therefore, pay thorough attention not to handle the input terminals, such as to apply to the input terminals a voltage lower than the GND respectively, so that any parasitic element will operate. Furthermore, do not apply a voltage to the input terminals when no power supply voltage is applied to the IC. In addition, even if the power supply voltage is applied, apply to the input terminals a voltage lower than the power supply voltage or within the guaranteed value of electrical characteristics.
- (10) Ground wiring pattern
If small-signal GND and large-current GND are provided, It will be recommended to separate the large-current GND pattern from the small-signal GND pattern and establish a single ground at the reference point of the set PCB so that resistance to the wiring pattern and voltage fluctuations due to a large current will cause no fluctuations in voltages of the small-signal GND. Pay attention not to cause fluctuations in the GND wiring pattern of external parts as well.
- (11) External capacitor
In order to use a ceramic capacitor as the external capacitor, determine the constant with consideration given to a degradation in the nominal capacitance due to DC bias and changes in the capacitance due to temperature, etc.
- (12) Thermal shutdown circuit (TSD)
When junction temperatures become 175°C (typ) or higher, the thermal shutdown circuit operates and turns a switch OFF. The thermal shutdown circuit, which is aimed at isolating the LSI from thermal runaway as much as possible, is not aimed at the protection or guarantee of the LSI. Therefore, do not continuously use the LSI with this circuit operating or use the LSI assuming its operation.
- (13) Thermal design
Perform thermal design in which there are adequate margins by taking into account the permissible dissipation (Pd) in actual states of use.
- (14) Selection of coil
Select the low DCR inductors to decrease power loss for DC/DC converter.

● Ordering part number

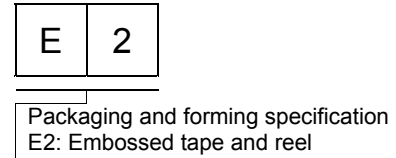
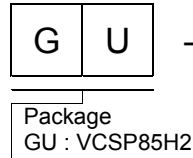
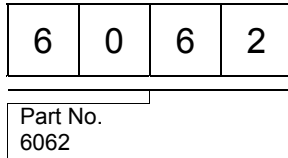
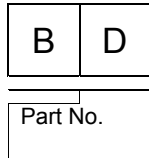

VCSP85H2 (BD6062GU)

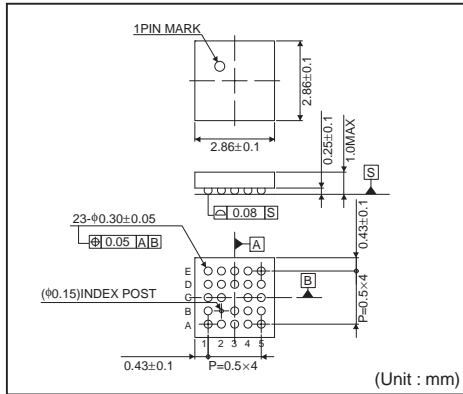

<Tape and Reel information>

Tape	Embossed carrier tape
Quantity	2500pcs
Direction of feed	E2 (The direction is the 1 pin of product is at the upper left when you hold reel on the left hand and you pull out the tape on the right hand)

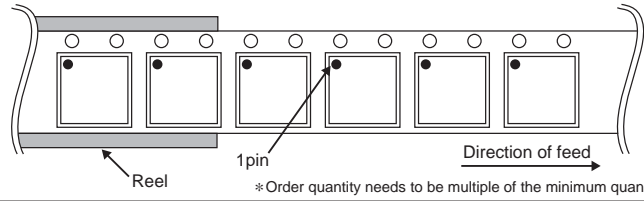

Notes

No copying or reproduction of this document, in part or in whole, is permitted without the consent of ROHM Co.,Ltd.

The content specified herein is subject to change for improvement without notice.

The content specified herein is for the purpose of introducing ROHM's products (hereinafter "Products"). If you wish to use any such Product, please be sure to refer to the specifications, which can be obtained from ROHM upon request.

Examples of application circuits, circuit constants and any other information contained herein illustrate the standard usage and operations of the Products. The peripheral conditions must be taken into account when designing circuits for mass production.

Great care was taken in ensuring the accuracy of the information specified in this document. However, should you incur any damage arising from any inaccuracy or misprint of such information, ROHM shall bear no responsibility for such damage.

The technical information specified herein is intended only to show the typical functions of and examples of application circuits for the Products. ROHM does not grant you, explicitly or implicitly, any license to use or exercise intellectual property or other rights held by ROHM and other parties. ROHM shall bear no responsibility whatsoever for any dispute arising from the use of such technical information.

The Products specified in this document are intended to be used with general-use electronic equipment or devices (such as audio visual equipment, office-automation equipment, communication devices, electronic appliances and amusement devices).

The Products specified in this document are not designed to be radiation tolerant.

While ROHM always makes efforts to enhance the quality and reliability of its Products, a Product may fail or malfunction for a variety of reasons.

Please be sure to implement in your equipment using the Products safety measures to guard against the possibility of physical injury, fire or any other damage caused in the event of the failure of any Product, such as derating, redundancy, fire control and fail-safe designs. ROHM shall bear no responsibility whatsoever for your use of any Product outside of the prescribed scope or not in accordance with the instruction manual.

The Products are not designed or manufactured to be used with any equipment, device or system which requires an extremely high level of reliability the failure or malfunction of which may result in a direct threat to human life or create a risk of human injury (such as a medical instrument, transportation equipment, aerospace machinery, nuclear-reactor controller, fuel-controller or other safety device). ROHM shall bear no responsibility in any way for use of any of the Products for the above special purposes. If a Product is intended to be used for any such special purpose, please contact a ROHM sales representative before purchasing.

If you intend to export or ship overseas any Product or technology specified herein that may be controlled under the Foreign Exchange and the Foreign Trade Law, you will be required to obtain a license or permit under the Law.



Thank you for your accessing to ROHM product informations.
More detail product informations and catalogs are available, please contact us.

ROHM Customer Support System

<http://www.rohm.com/contact/>