

MITSUBISHI <LINEAR ICs>  
**M51923P,FP**

**DUAL COMPARATOR**

**DESCRIPTION**

The M51923 is a dual (two independent) comparator and operates over a wide voltage range from a single supply voltage. The M51923 has a characteristic of low power dissipation but enables high output drive, and fits to wide ranged applications, for example CR timer, oscillator, etc.

**FEATURES**

- Low input current ..... 25nA(typ.)
- Wide supply voltage range ..... 2.5V~28V
- Low dissipation current ..... 0.4mA(typ.)(All output OFF)  
 1.5mA(typ.)(All output ON)
- Enables high output drive .....  $V_{OL}=0.15V$ (typ.)  
 (Output current 20mA)

**APPLICATION**

Voltage comparator, window comparator, CR timer, time delay circuit, oscillator, etc.

**RECOMMENDED OPERATING CONDITIONS**

- Supply voltage range ..... 2.5~28V
- Rated supply voltage ..... 12V

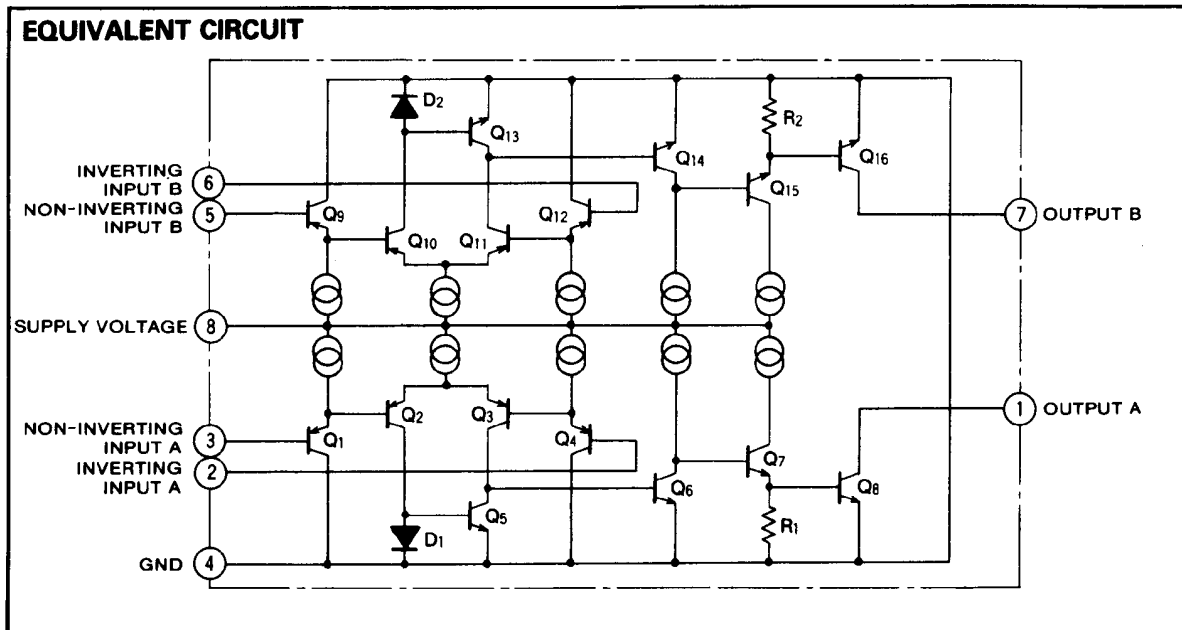
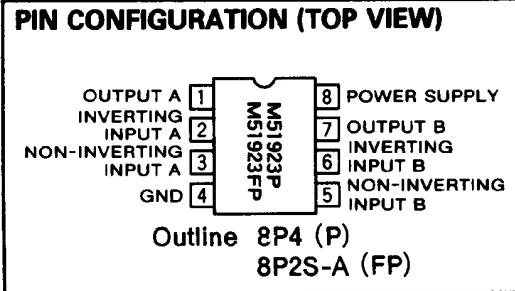

**DUAL COMPARATOR**

**ABSOLUTE MAXIMUM RATINGS** ( $T_a=25^\circ\text{C}$ , unless otherwise noted)

Symbol	Parameter	Conditions	Ratings	Unit
$V_{CC}$	Supply voltage		28	V
$V_{ID}$	Differential input voltage		$V_{CC}$	V
$V_{ICM}$	Common mode input voltage range		$-0.3 \sim V_{CC}$	V
$I_{sink}$	Output sink current		80	mA
$V_{OH}$	"H" output voltage		30	V
$P_d$	Power dissipation		650(DIP)/300(FP)	mW
$T_{opr}$	Operating temperature		$-20 \sim +75$	$^\circ\text{C}$
$T_{stg}$	Storage temperature		$-40 \sim +125$	$^\circ\text{C}$

**ELECTRICAL CHARACTERISTICS** ( $T_a=25^\circ\text{C}$ ,  $V_{CC}=2.5 \sim 28\text{V}$ , unless otherwise noted)

Symbol	Parameter	Test conditions	Limits			Unit
			Min	Typ	Max	
$V_{CC}$	Supply voltage range		2.5		28	V
$I_{CC1}$	Circuit current 1	ALL OUTPUT ON		1.5	2.5	mA
$I_{CC2}$	Circuit current 2	ALL OUTPUT OFF		0.4	0.8	mA
$V_{I\ominus}$	Inverting input voltage range	NOTE	0		$V_{CC}-1.5$	V
$V_{I\oplus}$	Non-inverting input voltage range	NOTE	0		$V_{CC}-1.5$	V
$V_{IO}$	Input offset voltage			2	5	mV
$I_{I\ominus}$	Inverting input current			25	150	nA
$I_{I\oplus}$	Non-inverting input current			25	150	nA
$I_{IO}$	Input offset current			5	50	nA
$V_{OL}$	"L" output voltage	$I_{sink}=20\text{mA}$		0.15	0.4	V
		$I_{sink}=80\text{mA}$		1		
$I_{LO}$	Output leak current				0.1	$\mu\text{A}$
$t_{PLH}$	Output "L→H" propagation delay time			2		$\mu\text{s}$
$t_{PHL}$	Output "H→L" propagation delay time			0.2		$\mu\text{s}$

NOTE) Either inverting or non-inverting inputs (reference side) should be within this range. (Abnormal operation will not occur when the other is within the range of 0 to  $V_{CC}$ .)

**TYPICAL CHARACTERISTICS** ( $T_a=25^\circ\text{C}$ , unless otherwise noted)

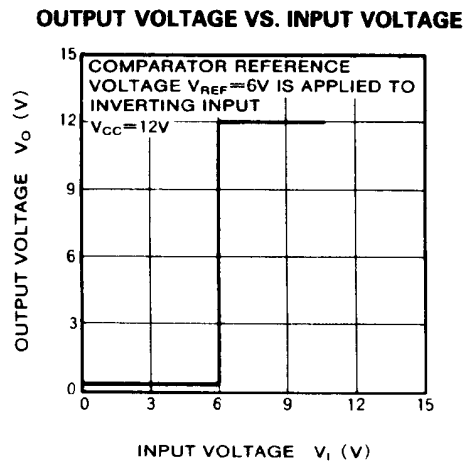
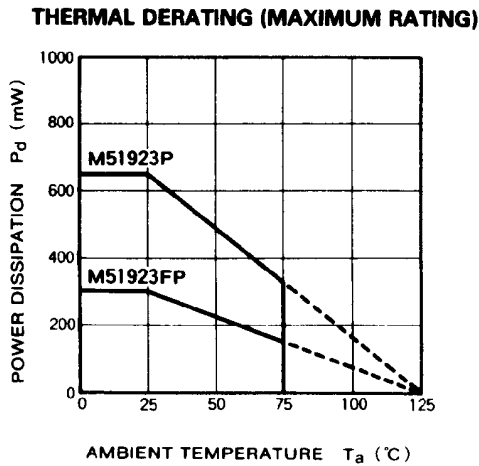

**INPUT CURRENT VS. INPUT VOLTAGE**

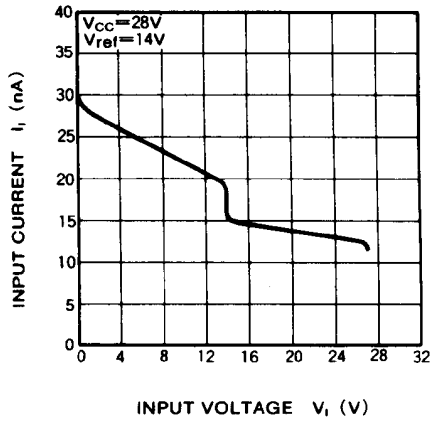

**INPUT CURRENT VS. SUPPLY VOLTAGE**

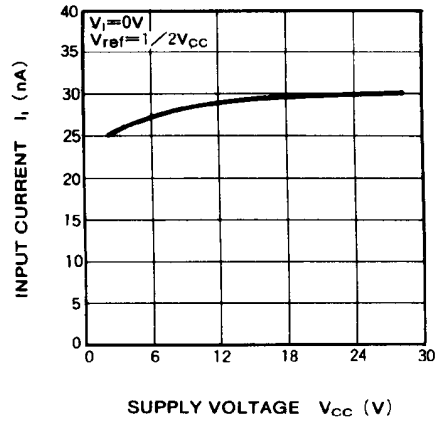

**CIRCUIT CURRENT VS. SUPPLY VOLTAGE**

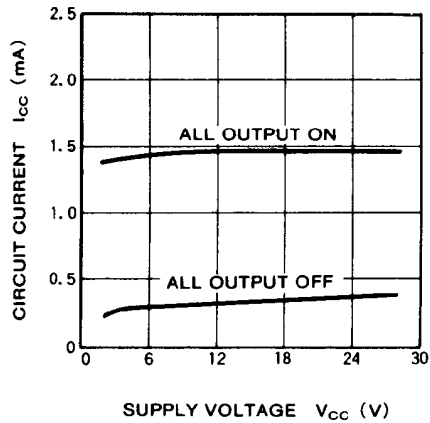

**"L" OUTPUT VOLTAGE VS. OUTPUT SINK CURRENT**

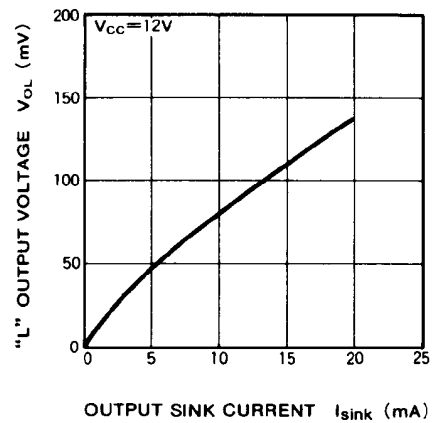

**CIRCUIT CURRENT VS. AMBIENT TEMPERATURE**

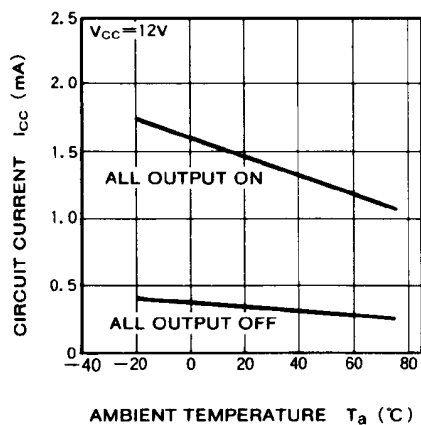

**OUTPUT CURRENT VS. AMBIENT TEMPERATURE**

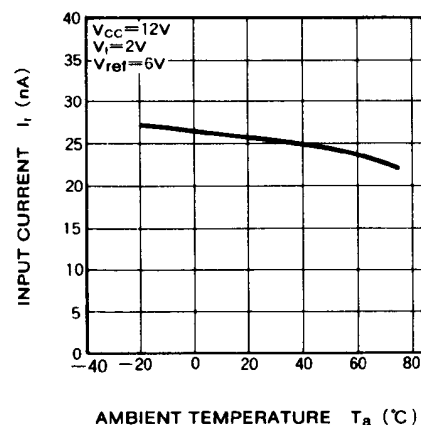

**DUAL COMPARATOR**

**"L" OUTPUT VOLTAGE VS.  
AMBIENT TEMPERATURE**

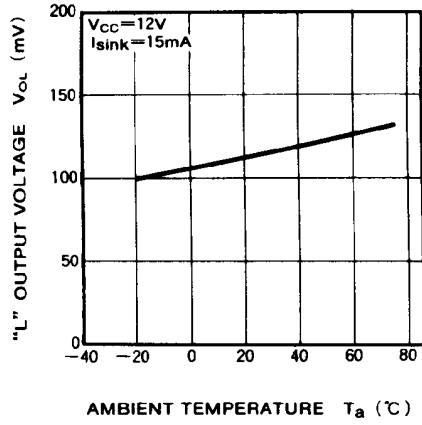

**OUTPUT LEAK CURRENT VS.  
AMBIENT TEMPERATURE**

