

Description

The 3842A(AM)/43A(AM)/44A(AM)/45A(AM) are fixed frequency current mode PWM controller. They are specially designed for OFF-Line and DC to DC converter applications with a minimal external components. Internally implemented circuits include a trimmed oscillator for precise duty cycle control, a temperature compensated reference, high gain error amplifier, current sensing comparator, and a high current totem pole output ideally suited for driving a power MOSFET. Protection circuitry includes built undervoltage lockout and current limiting. The 3842A(AM) and 3844A(AM) have UVLO thresholds of 16 V (on) and 10 V (off). The corresponding thresholds for the 3843A(AM)/45A(AM) are 8.4V (on) and 7.6V (off). The MIK3842A(AM) and MIK3843A(AM) can operate within 100% duty cycle. The 3844A(AM) and UC3845A(AM) can operate within 50% duty cycle. The 384XA(AM) has Start-Up Current 0.17mA (typ).

Features

- Low Start-Up and Operating Current
- High Current Totem Pole Output
- Undervoltage Lockout With Hysteresis
- Operating Frequency Up To 300KHz (384XA)
500KHz (384XAM)

Pin Connection

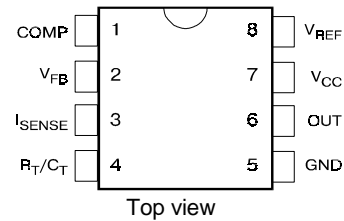

Block diagram

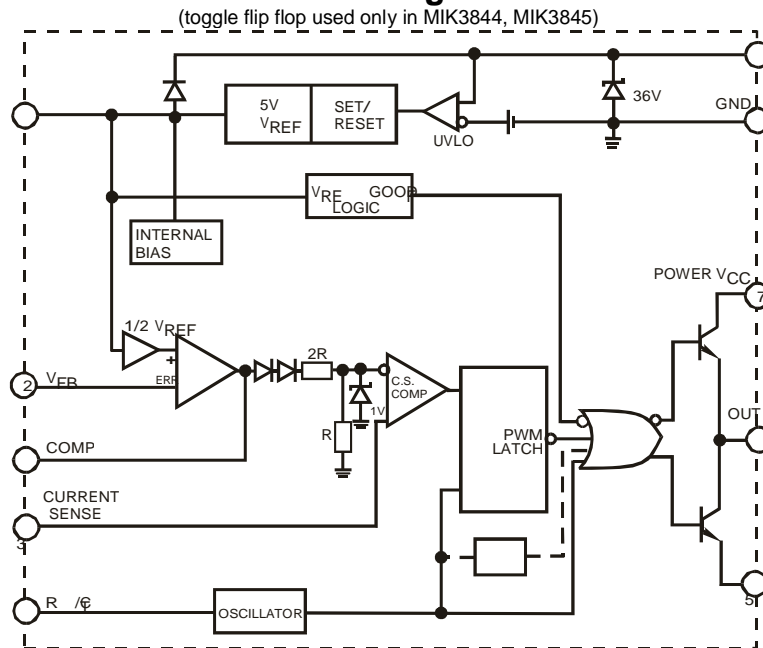

Absolute Maximum Ratings

| Symbol | Parameter | Maximum | Units |
|-----------------|--|-------------|------------------|
| V_{CC} | Supply Voltage (low impedance source) | 30 | V |
| I_o | Output Current | ± 1 | A |
| V_i | Input Voltage (Analog Inputs pins 2,3) | -0.3 to 5.5 | V |
| $I_{SINK(E,A)}$ | Error Amp Output Sink Current | 10 | mA |
| P_o | Power Dissipation ($T_A=25^\circ\text{C}$) | 1 | W |
| T_{stg} | Storage Temperature Range | -65 to 150 | $^\circ\text{C}$ |
| T_L | Lead Temperature (soldering 5 sec.) | 260 | $^\circ\text{C}$ |

Electrical characteristics

(* $V_{CC}=15V$, $R_T=10k\Omega$, $C_T=3.3nF$, $T_A=0^{\circ}C$ to $+70^{\circ}C$, unless otherwise specified)

| Characteristics | Symbol | Test Conditions | Min | Typ | Max | Units | |
|--|--------------------------|--|-----------|------|------|---------|-----|
| Reference Section | | | | | | | |
| Reference Output Voltage | V_{REF} | $T_J = 25^{\circ}C$, $I_{REF} = 1\text{ mA}$ | 4.9 | 5.0 | 5.1 | V | |
| Line Regulation | ΔV_{REF} | $12V \leq V_{CC} \leq 25V$ | | 6.0 | 20 | mV | |
| Load Regulation | ΔV_{REF} | $1\text{ mA} \leq I_{REF} \leq 20\text{ mA}$ | | 6.0 | 25 | | |
| Short Circuit Output Current | I_{SC} | $T_A = 25^{\circ}C$ | | -100 | -180 | mA | |
| Oscillator Section | | | | | | | |
| Oscillation Frequency | f | $T_J = 25^{\circ}C$ | MIK384XA | 47 | 50 | 57 | KHz |
| | | | MIK384XAM | 47 | 52 | 57 | |
| Frequency Change with Voltage | $\Delta f/\Delta V_{CC}$ | $12V \leq V_{CC} \leq 25V$ | | 0.05 | 1.0 | % | |
| Oscillator Amplitude | $V_{(OSC)}$ | (peak to peak) | | 1.6 | | V | |
| Error Amplifier Section | | | | | | | |
| Input Bias Current | I_{BIAS} | $V_{FB}=3V$ | | -0.1 | -2 | μA | |
| Input Voltage | $V_{(I.E.A)}$ | $V_{pin1} = 2.5V$ | 2.42 | 2.5 | 2.58 | V | |
| Open Loop Voltage Gain | A_{VOL} | $2V \leq V_O \leq 4V$ | 65 | 90 | | dB | |
| Power Supply Rejection Ratio | PSRR | $12V \leq V_{CC} \leq 25V$ | 60 | 70 | | | |
| Output Sink Current | I_{SINK} | $V_{pin2} = 2.7V$, $V_{pin1} = 1.1V$ | 2 | 7 | | mA | |
| Output Source Current | I_{SOURCE} | $V_{pin2} = 2.3V$, $V_{pin1} = 5V$ | -0.5 | -1.0 | | mA | |
| High Output Voltage | V_{OH} | $V_{pin2} = 2.3V$, $R_L = 15K\Omega$ to GND | 5.0 | 6.0 | | V | |
| Low Output Voltage | V_{OL} | $V_{pin2} = 2.7V$, $R_L = 15K\Omega$ to PIN 8 | | 0.8 | 1.1 | | |
| Current Sense Section | | | | | | | |
| Gain | G_V | (Note 1 & 2) | 2.85 | 3.0 | 3.15 | V/V | |
| Maximum Input Signal | $V_{(MAX)}$ | $V_{pin1} = 5V$ (Note1) | 0.9 | 1.0 | 1.1 | V | |
| Supply Voltage Rejection | SVR | $12V \leq V_{CC} \leq 25V$ (Note 1) | | 70 | | dB | |
| Input Bias Current | I_{BIAS} | $V_{pin3} = 3V$ | | -3.0 | -10 | μA | |
| Output Section | | | | | | | |
| Low Output Voltage | V_{OL} | $I_{SINK} = 20\text{ mA}$ | | 0.08 | 0.4 | V | |
| | | $I_{SINK} = 200\text{ mA}$ | | 1.4 | 2.2 | | |
| High Output Voltage | V_{OH} | $I_{SINK} = 20\text{ mA}$ | 13 | 13.5 | | | |
| | | $I_{SINK} = 200\text{ mA}$ | 12 | 13.0 | | | |
| Rise Time | t_R | $T_J = 25^{\circ}C$, $C_L = 1nF$ (Note 3) | | 45 | 150 | nS | |
| Fall Time | t_F | $T_J = 25^{\circ}C$, $C_L = 1nF$ (Note 3) | | 35 | 150 | | |
| Undervoltage Lockout Section | | | | | | | |
| Start Theshold | $V_{TH(ST)}$ | MIK3842A(AM)/44A(AM) | 14.5 | 16.0 | 17.5 | V | |
| | | MIK3843A(AM)/45A(AM) | 7.8 | 8.4 | 9.0 | | |
| Min. Operating Voltage (After Turn On) | $V_{OPR(min)}$ | MIK3842A(AM)/44A(AM) | 8.5 | 10 | 11.5 | V | |
| | | MIK3843A(AM)/45A(AM) | 7.0 | 7.6 | 8.2 | | |
| PWM Section | | | | | | | |
| Max. Duty Cycle | $D_{(MAX)}$ | MIK3842A(AM)/43A(AM) | 95 | 97 | 100 | % | |
| | | MIK3844A(AM)/45A(AM) | 47 | 48 | 50 | | |
| Min. Duty Cycle | $D_{(MAX)}$ | | | | 0 | | |
| Total Standby Current | | | | | | | |
| Start-Up Current | I_{ST} | MIK384XA(AM) | | 0.17 | 0.3 | mA | |
| Operating Supply Current | $I_{CC(OPR)}$ | $V_{pin3} = V_{pin2} = 0V$ | | 13 | 17 | | |
| Zener Voltage | V_Z | $I_{CC}=25\text{ mA}$ | 30 | 38 | | V | |

* - Adjust V_{CC} above the start threshold before setting it to 15V.

Note 1: Parameter measured at trip point of latch with $V_{pin2}=0$.

Note 2: Gain defined as $A=\Delta V_{pin1}/\Delta V_{pin3}$; $0 \leq V_{pin3} \leq 0.8V$.

Note 3: These parameters, although guaranteed, are not 100% tested in production.

Pin functions

| N | Function | Description |
|---|--------------------------------|---|
| 1 | COMP | This pin is the Error Amplifier output and is made for loop compensation. |
| 2 | V _{FB} | This is the inverting input of the Error Amplifier. It is normally connected to the switching power supply output through a resistor divider. |
| 3 | I _{SENSE} | A voltage proportional to inductor current is connected to this input. The PWM uses this information to terminate the output switch conduction. |
| 4 | R _T /C _T | The oscillator frequency and maximum Output duty cycle are programmed by connecting resistor R _T to V _{ref} and capacitor C _T to ground. |
| 5 | GROUND | This pin is the combined control circuitry and power ground. |
| 6 | OUTPUT | This output directly drives the gate of a power MOSFET. Peak currents up to 1A are sourced and sink by this pin. |
| 7 | V _{CC} | This pin is the positive supply of the integrated circuit. |
| 8 | V _{ref} | This is the reference output. It provides charging current for capacitor C _T through resistor R _T . |

Application information

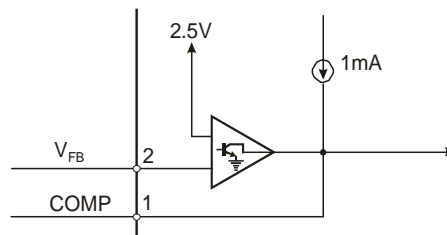

Figure 1. Error Amp Configuration

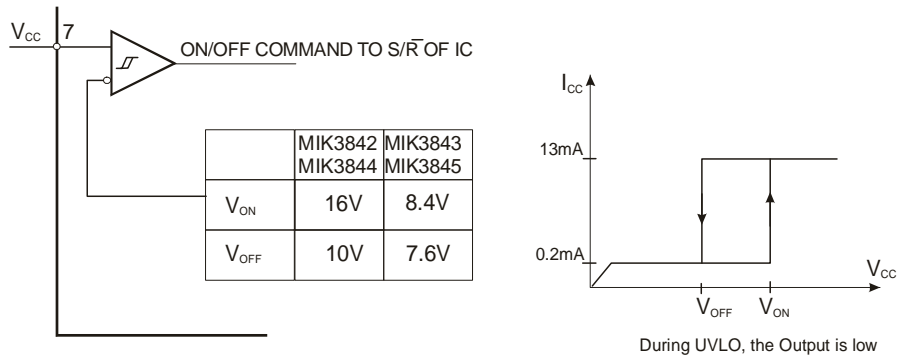

Figure 2. Undervoltage Lockout

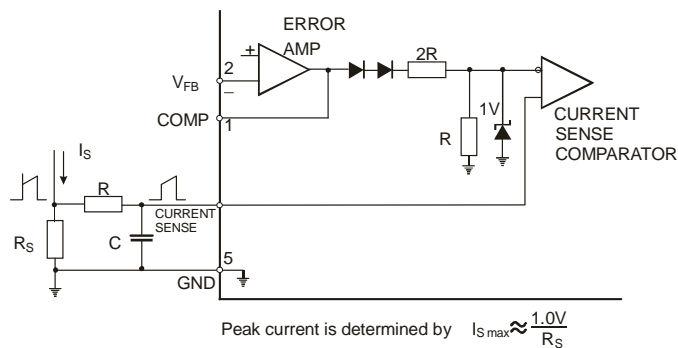

Figure 3. Current Sense Circuit

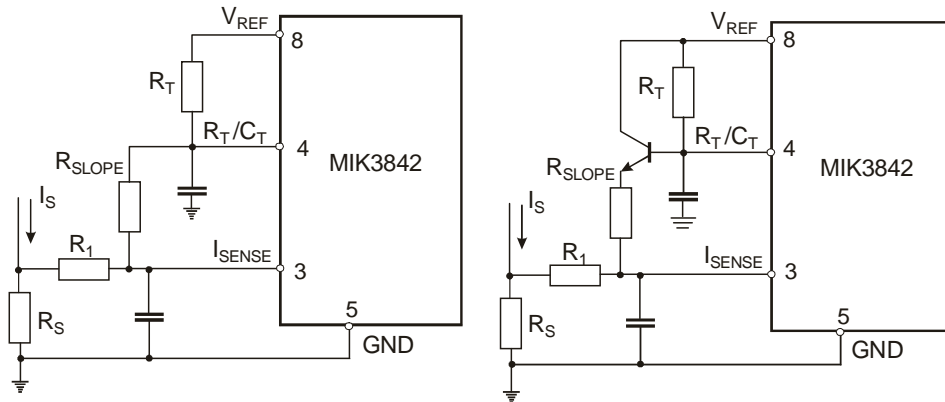
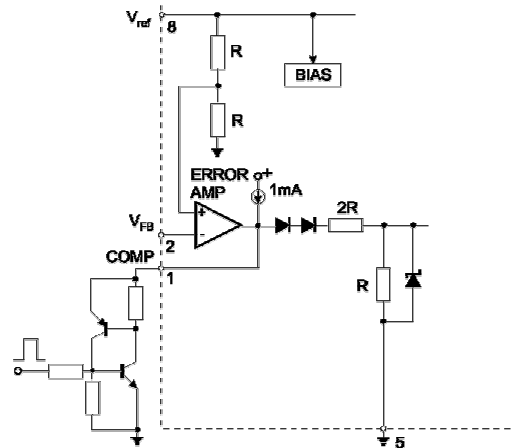
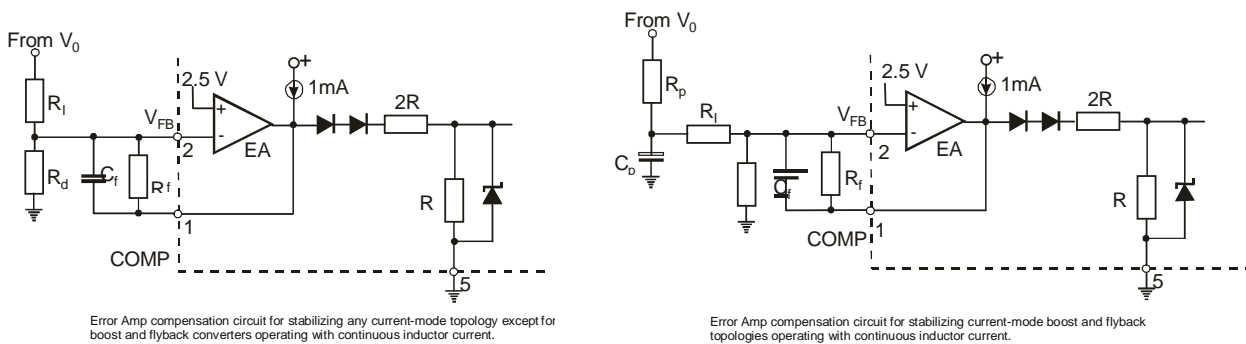

Figure 4. Slope Compensation Techniques



SCR must be selected for a holding current of less than 0.5mA.
The simple two transistor circuit can be used in place of the SCR as shown.

Figure 5. Latched Shutdown



Error Amp compensation circuit for stabilizing any current-mode topology except for boost and flyback converters operating with continuous inductor current.

Error Amp compensation circuit for stabilizing current-mode boost and flyback topologies operating with continuous inductor current.

Figure 6. Error Amplifier Compensation

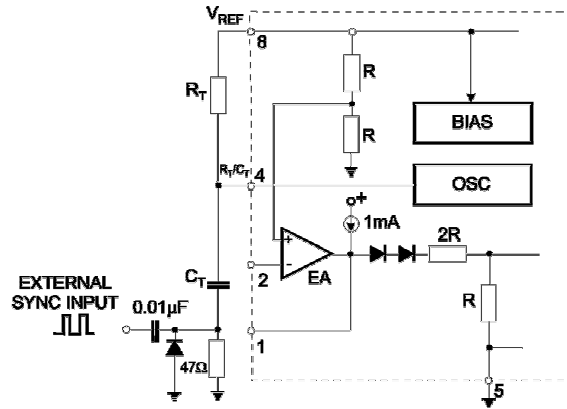

Figure 7. External Clock Synchronization

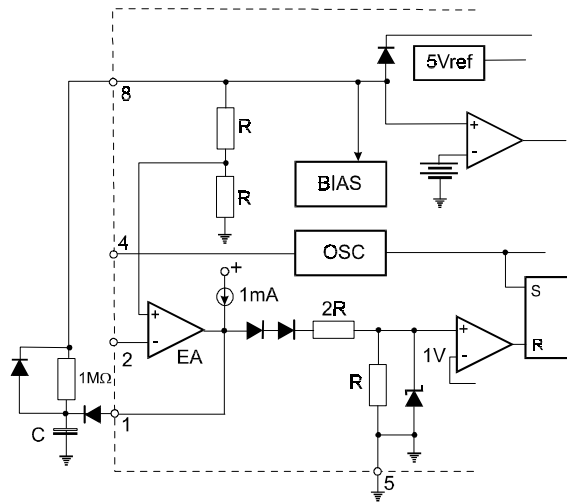

Figure 8. Soft-Start Circuit

Typical Performance Characteristics

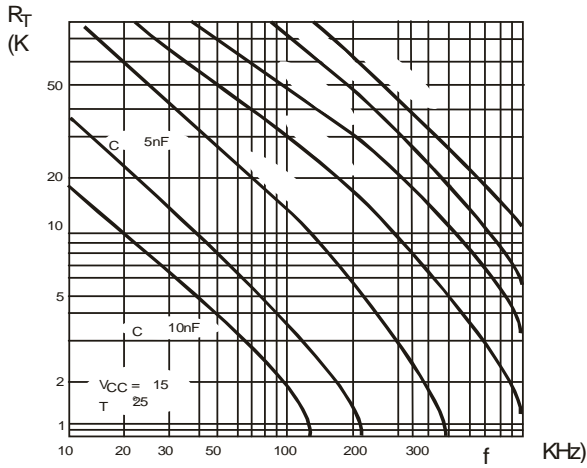

Figure 1. Timing Resistor vs. Oscillator Frequency.

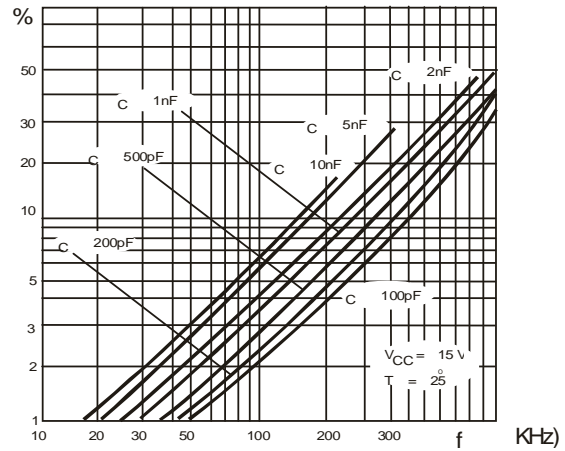

Figure 2. Output Dead-Time vs. Oscillator Frequency

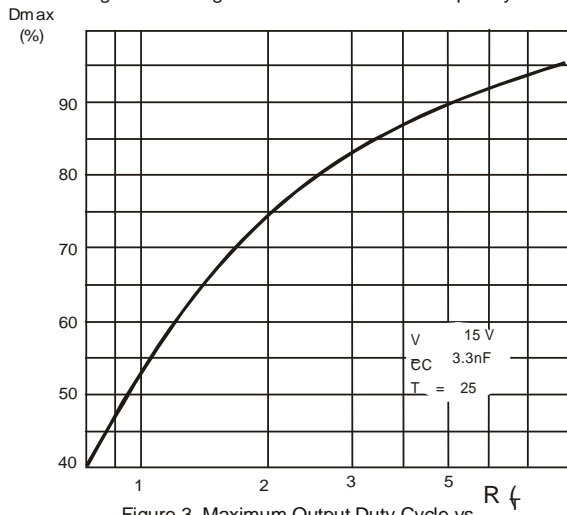

Figure 3. Maximum Output Duty Cycle vs. Timing Resistor (MIK3842/4 3)

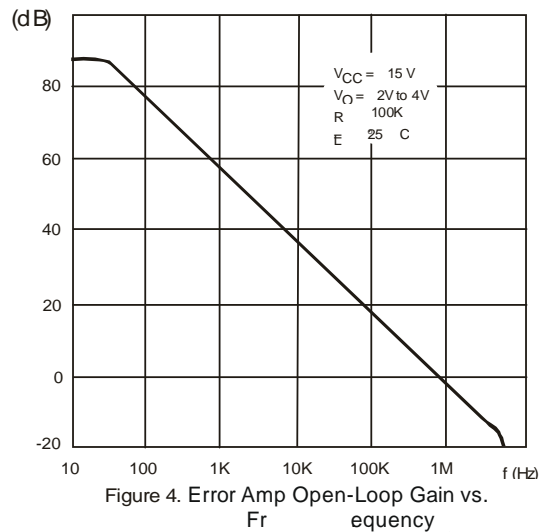

Figure 4. Error Amp Open-Loop Gain vs. Frequency

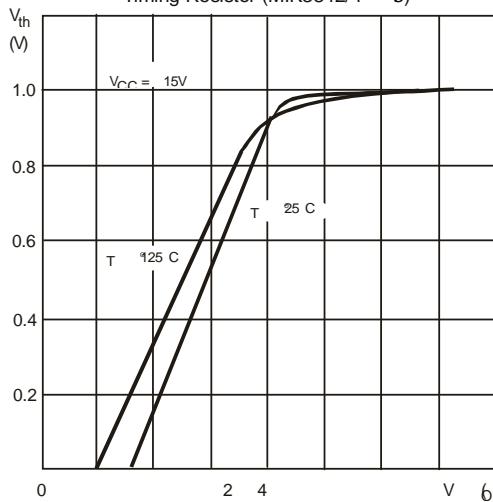

Figure 5. Current Sense Input Threshold vs. Error Amp Output Voltage.

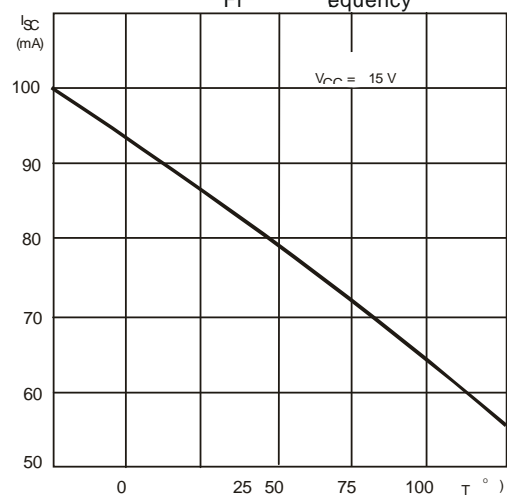

Figure 6. Reference Short Circuit Current vs. Temperature.

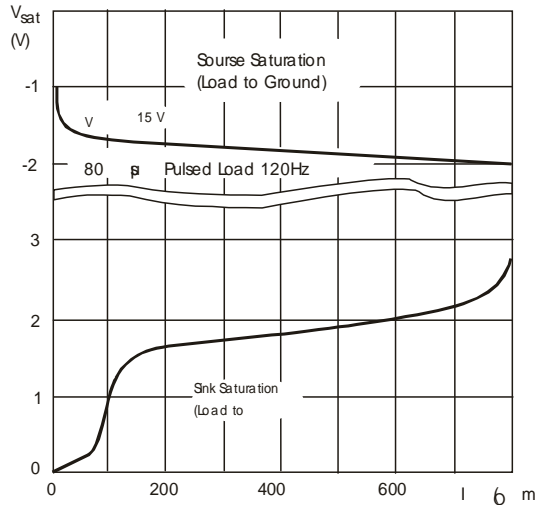

Figure 7 Output Saturation Voltage vs. Load

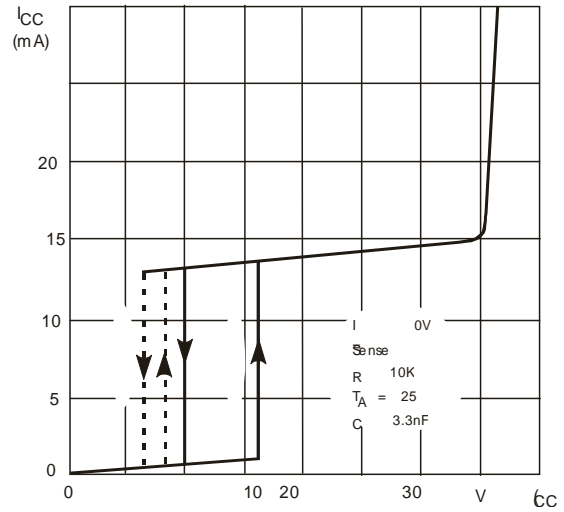

Figure 8 Supply Current vs. Supply

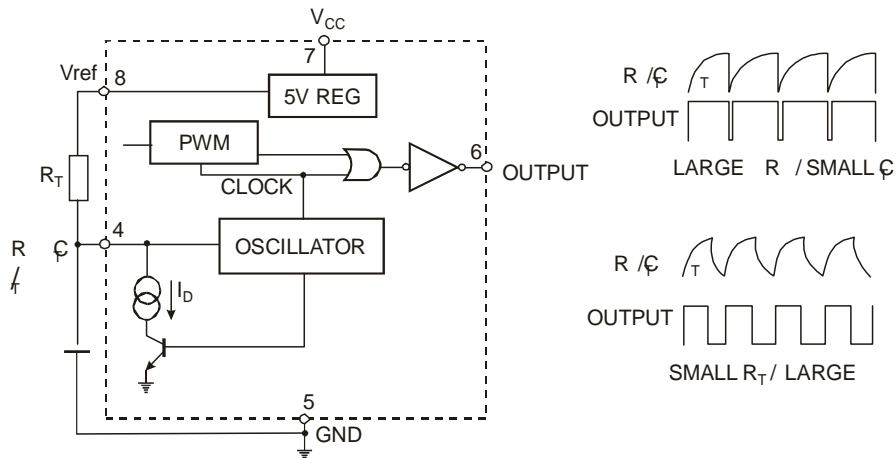

Figure 9. Oscillator and Output Waveforms

Ordering Information

| ORDERING NUMBER | PACKAGE | MARKING |
|---------------------|---------------|-----------------------|
| 3842 / 43 / 44 / 45 | SOP-8 / DIP-8 | KA3842 / 43 / 44 / 45 |

Address : 北京市海淀区永定路 88 号长银大厦 6A06--6A07

Rm 6A07, Changyin Office Building, No.88, Yong Ding Road, Hai Dian District, Beijing

Postalcode:100039

Tel: 86-010-58895780 / 81 / 82 / 83 / 84 Fax : 010-58895793

Http://www.estek.com.cn

Email:sales@estek.com.cn

REV No:01-060815