

Features

- 3.3V and 5V output versions
- Guaranteed 3A output load current
- Requires small number of external components
- Excellent line and load regulation
- 150kHz fixed frequency internal oscillator
- Built-in TTL On/Off Control
- Low power standby mode, I_Q typically 80uA
- Built-in current limit protection
- Built-in thermal shutdown circuit.
- Operating voltage: 4.5V~25V
- TO-265 package

Description

The AT1796 series of regulators are step-down (buck) DC/DC converter, capable of driving a 3A load with excellent line and load regulation. Requiring a minimum number of external components, these regulators are simple to use .

The AT1796 series operates at a switching frequency of 150kHz. Available in a standard 5-lead TO-263 surface mount package. It include a guaranteed $\pm 4\%$ tolerance on output voltage under specified input voltage and output load conditions, and $\pm 15\%$ on the oscillator frequency.

Applications

High-efficiency step-down regulator
 TFT Scalar Board
 On-card switching regulators

Block Diagram

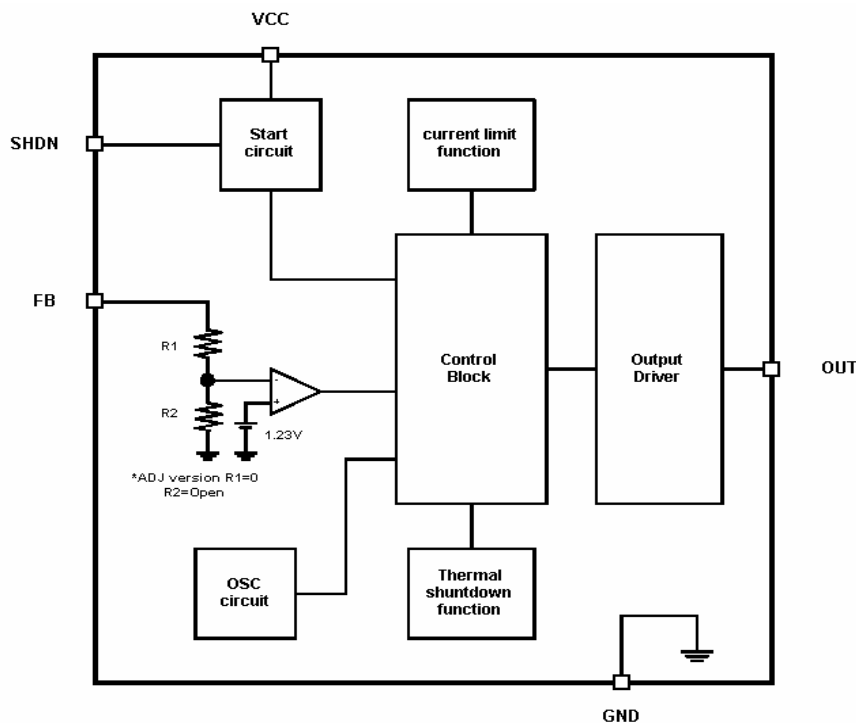

Aimtron reserves the right without notice to change this circuitry and specifications.

Pin Configuration

Surface Mount Package
5-Lead TO-265

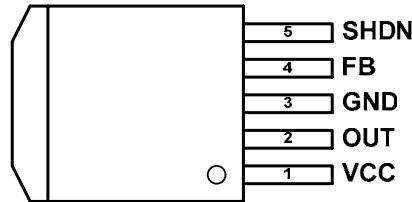

*GND(Metal Tab)

Ordering Information

Part number	Package	Marking
AT1796-50	TO-265(5.0V version)	AT1796-50A
AT1796-50 PBF	TO-265(5.0V version),PB-Free	AT1796-50A,date code with one bottom line
AT1796-33	TO-265(3.3V version)	AT1796-33A
AT1796-33 PBF	TO-265(3.3V version),PB-Free	AT1796-33A,date code with one bottom line
AT1796-ADJ	TO-265(ADJ version)	AT1796-ADJ
AT1796-ADJ PBF	TO-265(ADJ version),PB-Free	AT1796-ADJ,date code with one bottom line

**For more marking information, contact our sales representative directly*

Pin Description

Symbol	Pin No.	Descript
VCC	1	Power Supply
OUT	2	Switch Node Connection to Inductor
GND	3	Power ground
FB	4	Output Feedback
SHDN	5	ON/OFF Control

7F, No.9, PARK AVENUE II, Science-Based Industrial Park, Hsinchu 300,Taiwan, R.O.C.

Tel: 886-3-563-0878
 2/15/2006 REV : 1.1

Fax: 886-3-563-0879

WWW: <http://www.aimtron.com.tw>
 Email: service@aimtron.com.tw

Absolute maximum ratings

Parameter	Symbol	Limits	unit
Power supply voltage	VCC	30	V
SHDN pin input voltage	V _{SHDN}	-0.3~+25	V
Power dissipation	P _d	Internally Limited	W
Operating Junction Temperature	T _J	-30~+125	°C
Storage temperature	T _{stg}	-65~+150	°C
Thermal Resistance from Junction to Ambient	θ _{JA}	19.4	°C/W
Thermal Resistance from Junction to Case	θ _{JC}	7.7	°C/W
Lead Temperature(Soldering, 5sec.)		260	°C
ESD Susceptibility *2	HBM	2	KV
	MM	200	V

1. Stresses beyond those listed under “Absolute Maximum Ratings” may cause permanent damage to the device. These are stress ratings only, and functional operation of the device at these or any other conditions beyond those indicated in the operational sections of the specifications is not implied. Exposure to absolute maximum rating conditions for extended periods may affect device reliability.
2. Device are ESD sensitive. Handling precaution recommended. The Human Body model is a 100pF capacitor discharged through a 1.5KΩ resistor into each pin.
3. θ_{JA} is measured with the component mounted on an evaluation PC board in free air that the required area of copper is 2.5in² (1 oz.) or larger.

Recommended operating conditions (T_A = 25°C)

Parameter	Symbol	Limits	unit
Power supply voltage	VCC	4.5~28	V
SHDN pin input voltage	V _{SHDN}	0~+20	V

Electrical characteristics

 (VCC = 12V, T_a = +25°C, unless otherwise noted.)

Parameter	Symbol	Condition	Values			Unit
			Min.	Typ.	Max.	
Quiescent Current	I _{OC}		--	5	10	mA
Stand-by quiescent Current	I _{SQC}	SHDN = 5V	--	80	200	μA
SHDN pin logic input voltage threshold	V _{IL}	Active mode	--	--	0.6	V
	V _{IH}	Standby mode	2.0	--	--	V
SHDN pin logic input current	I _{IL}	Active mode	--	0.02	5	μA
	I _{IH}	Standby mode	--	5	15	μA
<AT1796-3.3V>						
Output voltage	V _{OUT}	4.75 V _{CC} 28V 0.2A I _{LOAD} 3A	3.168	3.3	3.432	V
Efficiency	η	V _{in} = 12V, I _{LOAD} = 3A	73	--	--	%
<AT1796-5.0V>						
Output voltage	V _{OUT}	4.75 V _{CC} 28V 0.2A I _{LOAD} 3A	4.8	5.0	5.2	V
Efficiency	η	V _{in} = 12V, I _{LOAD} = 3A	--	80	--	%
<AT1796-ADJ>						
FB voltage	V _{FB}	4.75 V _{CC} 28V 0.2A I _{LOAD} 3A	1.193	1.230	1.267	V
Efficiency	η	V _{in} = 12V, I _{LOAD} = 3A, V _{OUT} = 3V	--	73	--	%
<Device parameters>						
Saturation voltage	V _{SAT}	I _{LOAD} = 3A	--	1.15	1.5	V
Oscillator frequency	F _{OSC}		127	150	173	kHz
Maximum duty cycle	D _{MAX}	FB = 0V	--	100	--	%
Minimum duty cycle	D _{MIN}	FB = 3.3V or 5V	--	0	--	%
Current limit	I _{CL}	Peak current	3.6	4.5	5.0	A
Output leakage current	I _{L1}	No diode, capacitor, inductor FB = 12V, Switching OFF, OUT = 0V	--	50	--	μA
	I _{L2}	V _{CC} = 28V	--	2	30	mA

CH1:SHDN CH2:5V Output CH3:OUT CH4:IIN

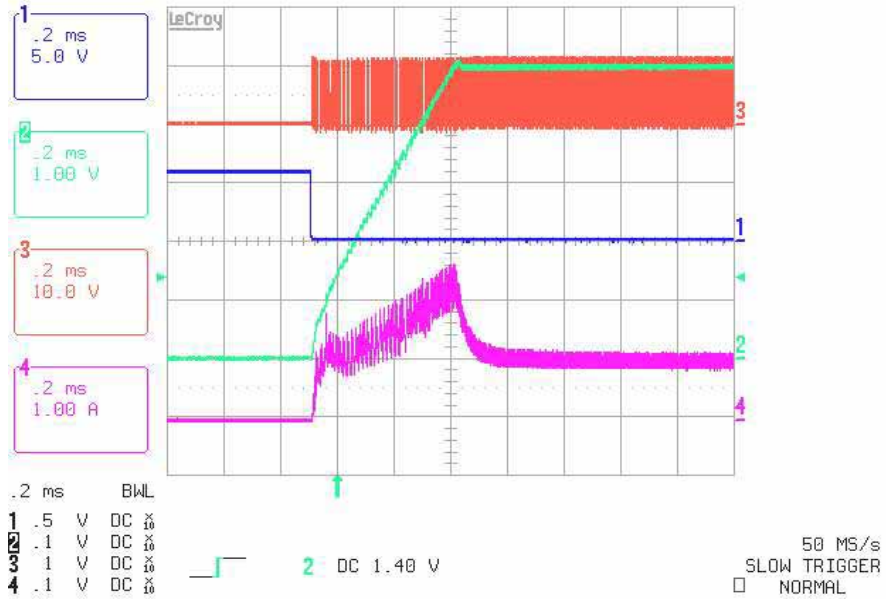

Fig1. 5V/2A Output

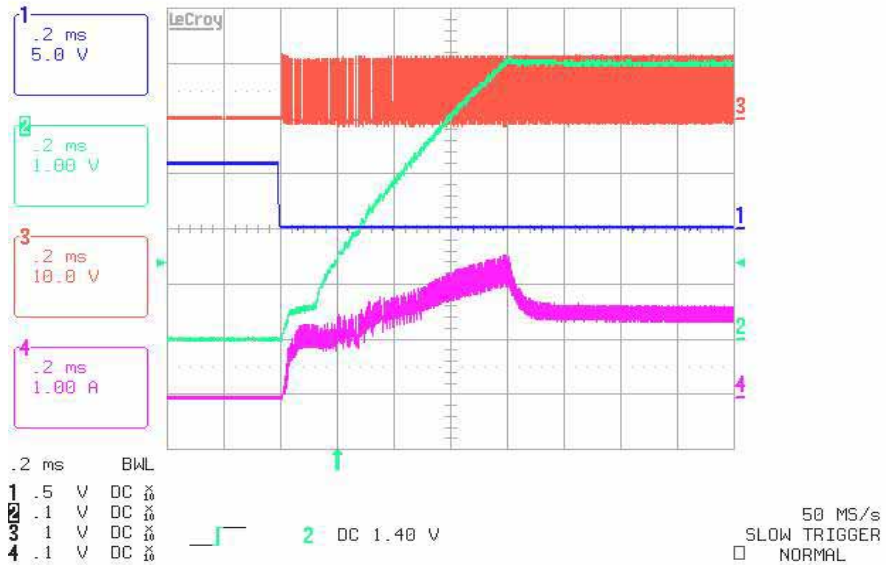

Fig2. 5V/3A Output

7F, No.9, PARK AVENUE II, Science-Based Industrial Park, Hsinchu 300, Taiwan, R.O.C.

Tel: 886-3-563-0878

Fax: 886-3-563-0879

WWW: <http://www.aimtron.com.tw>

2/15/2006 REV : 1.1

Email: service@aimtron.com.tw

Typical Performance Characteristics:

Continuous mode switching waveforms

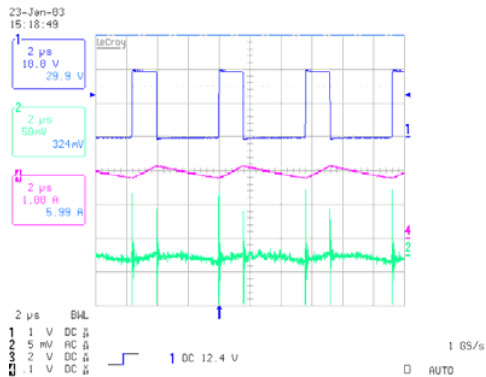
 $V_{IN}=20V$, $V_{OUT}=5V$, $I_{LOAD}=2A$, $L=33\mu H$
 $C_{OUT}=220\mu F$, $C_{OUT} ESR=50m\Omega$

Discontinuous mode switching waveforms

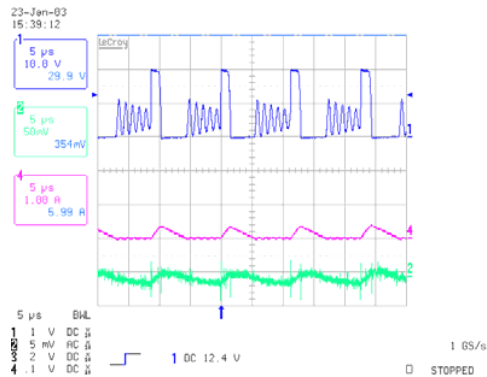
 $V_{IN}=20V$, $V_{OUT}=5V$, $I_{LOAD}=90mA$, $L=33\mu H$
 $C_{OUT}=220\mu F$, $C_{OUT} ESR=50m\Omega$

Load transient response for continuous mode

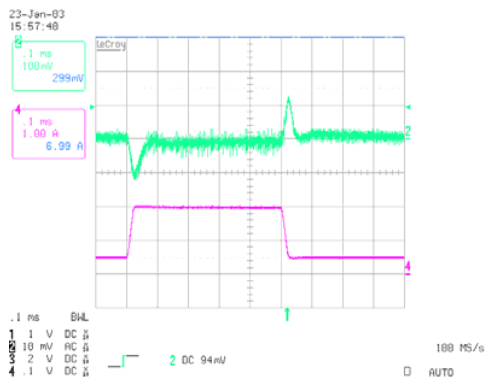
 $V_{IN}=20V$, $V_{OUT}=5V$, $I_{LOAD}=500mA$ to $2A$
 $L=33\mu H$, $C_{OUT}=220\mu F$, $C_{OUT} ESR=50m\Omega$

Adjustable Output Application Example :

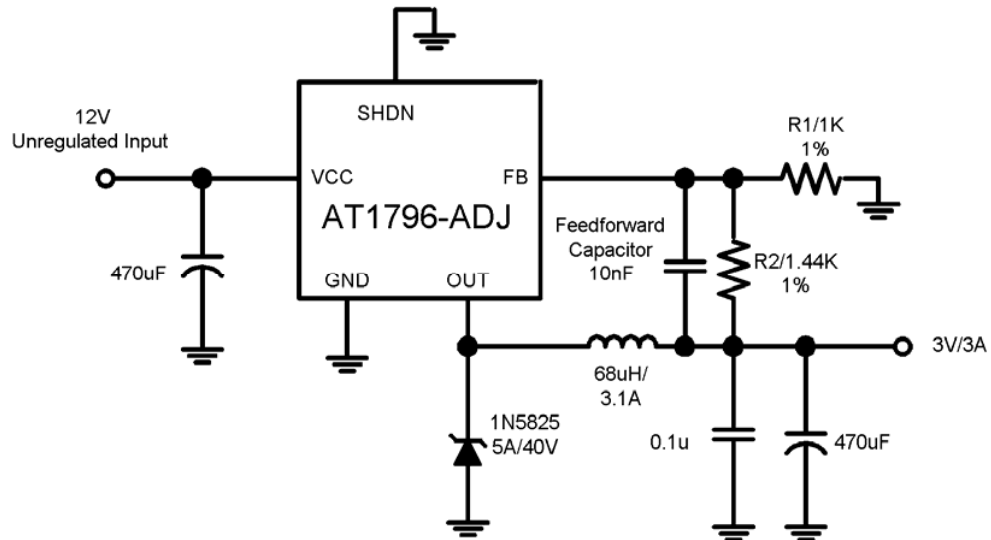

$$V_{OUT} = V_{FB} \left(1 + \frac{R2}{R1} \right)$$

$$V_{FB} = 1.23V$$

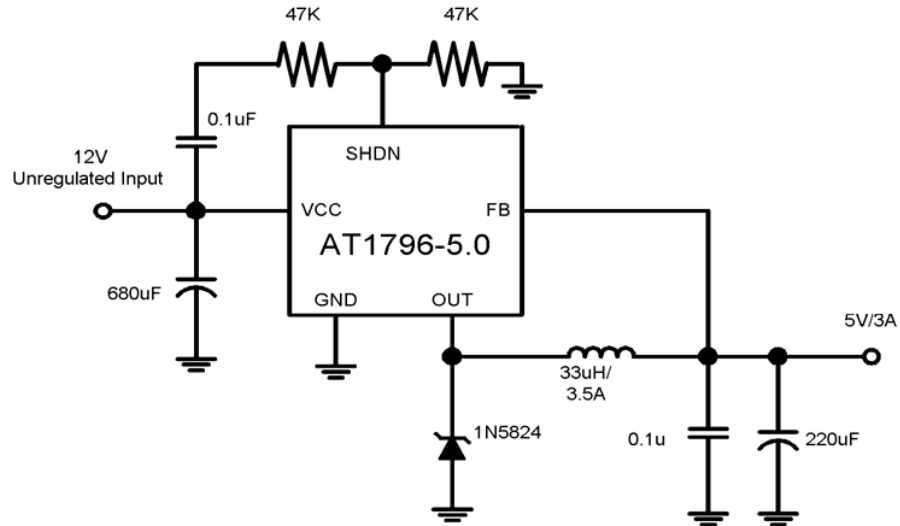
Application Circuit:

Delay Startup for Buck Regulator

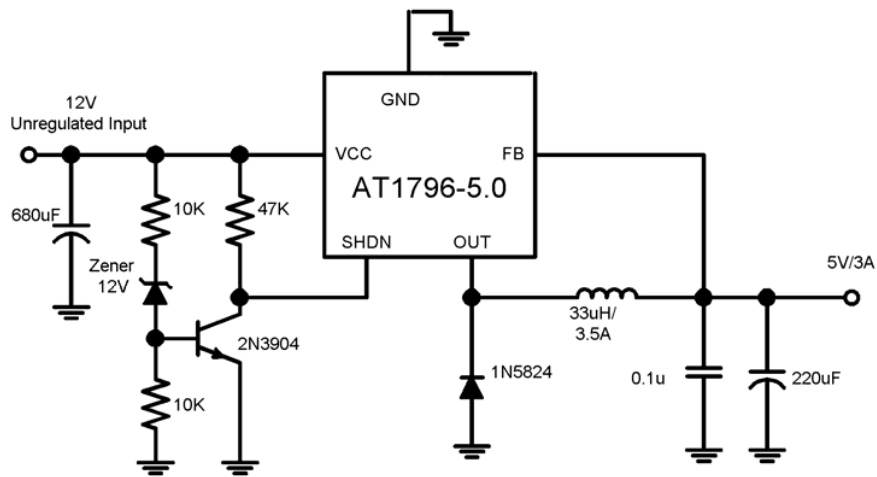

Undervoltage Lockout for Buck Regulator

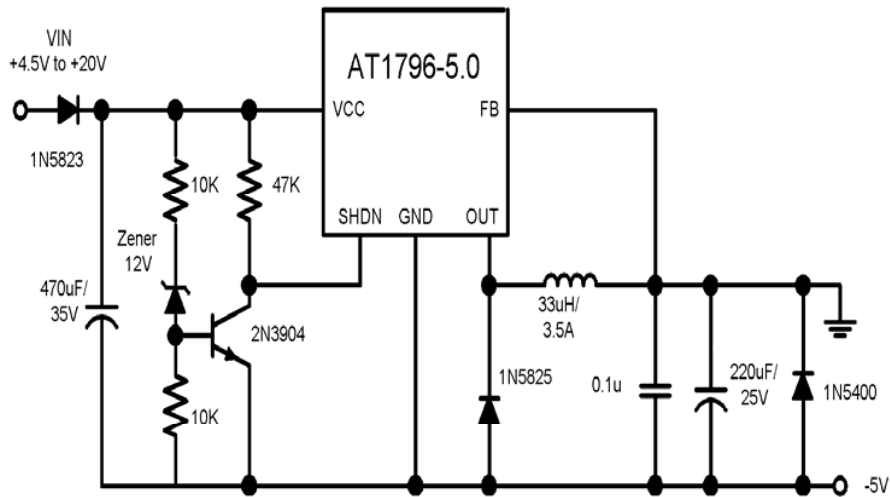

Inverting -5V Regulator with Undervoltage Lockout

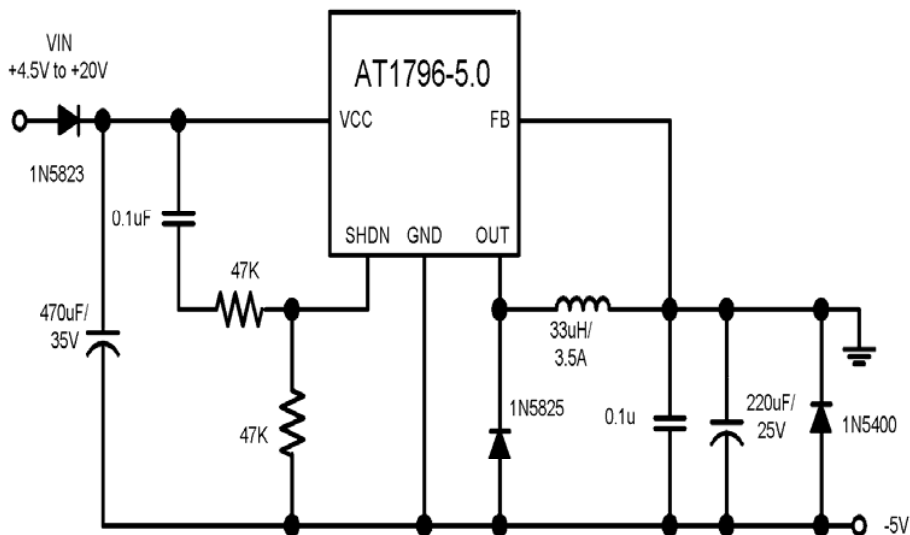

Inverting -5V Regulator with Delay Startup

7F, No.9, PARK AVENUE II, Science-Based Industrial Park, Hsinchu 300, Taiwan, R.O.C.

Tel: 886-3-563-0878
2/15/2006 REV : 1.1

Fax: 886-3-563-0879

WWW: <http://www.aimtron.com.tw>
Email: service@aimtron.com.tw

Application Data :
Quick Design Component Selection Table

Input/Output Condition			Inductor		Output Capacitor($\mu\text{F}/\text{V}$)			
Output Voltage (V)	Load Current (A)	Max. Input Voltage (V)	Inductance (μH)	Current (A)	Through Hole electrolytic		Surface Mount Tantalum	
					Nichicon PL Series	Panasonic HFQ Series	Sprague 595D Series	AVX TPS Series
5	3	8	22	3.5	560/25	560/25	330/10	220/10
		15	33	3.5	330/35	330/35	330/10	220/10
		25	47	3.5	270/35	330/35	330/10	220/10
	2	9	22	3.1	560/16	470/25	330/10	220/10
		15	68	3.1	180/35	180/35	270/10	100/10
		25	68	3.1	180/35	180/35	270/10	100/10
3.3	3	5	22	3.5	560/16	470/25	390/6.3	330/6.3
		12	22	3.5	560/25	560/35	390/6.3	330/6.3
		25	33	3.5	470/35	680/35	390/6.3	330/6.3
	2	6	22	3.1	470/35	470/25	390/6.3	330/6.3
		12	33	3.1	330/35	330/35	390/6.3	330/6.3
		25	47	3.1	270/50	330/35	330/10	220/10

Quick Design Component Selection Table for Adjustable Output

Output Voltage (V)	Through Hole Output Capacitor			Surface Mount Output Capacitor		
	Panasonic HFQ Series ($\mu\text{F}/\text{V}$)	Nichicon PL Series ($\mu\text{F}/\text{V}$)	Feedforward Capacitor	Panasonic HFQ Series ($\mu\text{F}/\text{V}$)	Nichicon PL Series ($\mu\text{F}/\text{V}$)	Feedforward Capacitor
2	820/35	820/35	33nF	330/6.3	470/4	33nF
4	560/35	470/35	10nF	330/6.3	390/6.3	10nF
6	470/25	470/25	3.3nF	220/10	330/10	3.3nF
9	330/25	330/25	1.5nF	100/16	180/16	1.5nF
12	330/25	330/25	1nF	100/16	180/16	1nF
15	220/35	220/35	680pF	68/20	120/20	680pF
24	220/35	150/35	560pF	33/25	33/25	220pF

Diode Selection Table

VR(V)	3A Diode		4~6A Diode	
	Surface Mount	Through Hole	Surface Mount	Through Hole
	Schottky	Schottky	Schottky	Schottky
20	SK32	1N5820 SR302 MBR320		1N5823 SR502 SB520
30	30WQ03 SK33	1N5821 MBR330 31DQ03	50WQ03	1N5824 SR503 SB530
40	SK34 MBRS340 30WQ04	1N5822 SR304 MBR340 31DQ04	50WQ04	1N5825 SR504 SB540
50	SK35 MBRS360 30WQ05 MURS320 30WF10	SR305 MBR350 31DQ05 MUR320	50WQ05 50WF10	SB550 50SQ080 MUR620 HER601

7F, No.9, PARK AVENUE II, Science-Based Industrial Park, Hsinchu 300, Taiwan, R.O.C.

 Tel: 886-3-563-0878
 2/15/2006 REV : 1.1

Fax: 886-3-563-0879

 WWW: <http://www.aimtron.com.tw>

 Email: service@aimtron.com.tw

Package outlines: TO-265

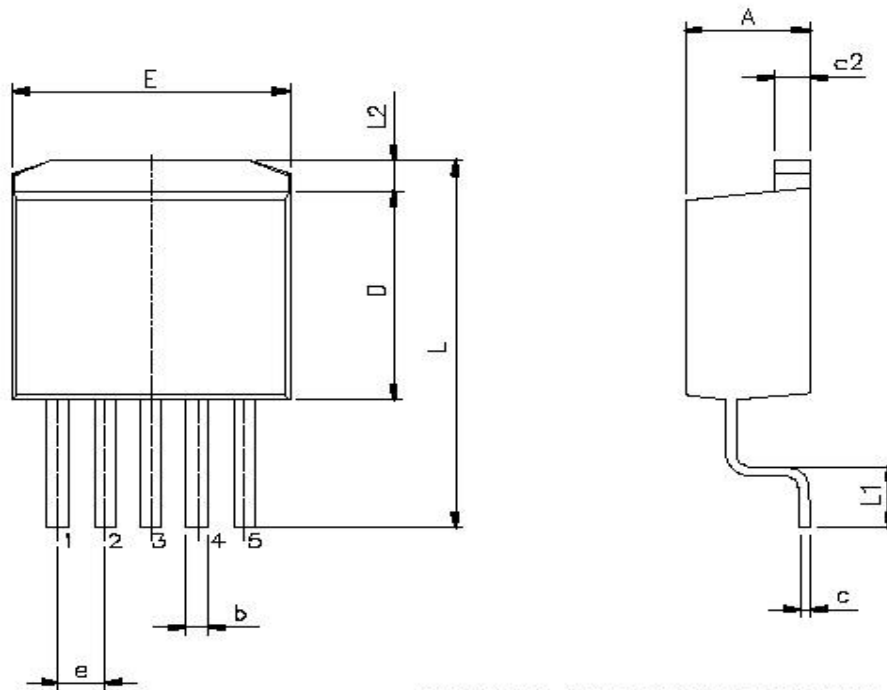

VARIATIONS (ALL DIMENSIONS SHOWN IN INCH)

SYMBOLS	MIN.	MAX.
A	0.160	0.190
b	0.027	0.037
c	0.015 TYP.	
c2	0.045	0.055
D	0.340	0.380
E	0.380	0.405
e	0.067 BSC.	
L	0.575	0.625
L1	0.090	0.110
L2	—	0.115

NOTES:

1. JEDEC OUTLINE : N/A

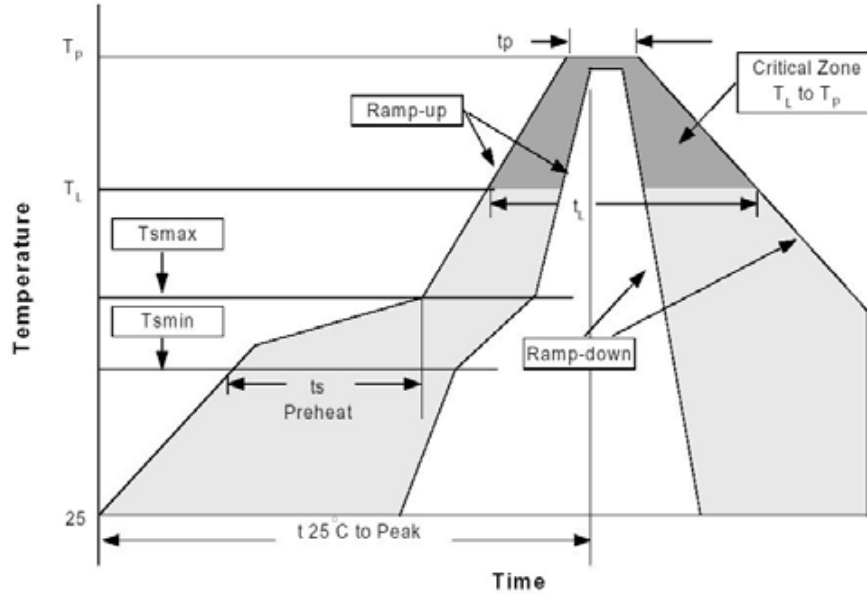
Reflow Profiles

Profile Feature	Sn-Pb Eutectic Assembly		Pb-Free Assembly	
	Large Body Pkg. thickness ≥2.5mm or Pkg. volume ≥350mm ³	Small Body Pkg. thickness <2.5mm or Pkg. volume <350mm ³	Large Body Pkg. thickness ≥2.5mm or Pkg. volume ≥350mm ³	Small Body Pkg. thickness ≥2.5mm or Pkg. volume ≥350mm ³
Average ramp-up rate (T _L to T _P)	3°C/second max.		3°C/second max.	
Preheat -Temperature Min(T _{smin}) -Temperature Max (T _{smax}) -Time (min to max)(t _s)	100°C 150°C 60-120 seconds		150°C 200°C 60-180 seconds	
T _{smax} to T _L -Ramp-up Rate			3°C/second max.	
Time maintained above: -Temperature (T _L) -Time (t _L)	183°C 60-150 seconds		217°C 60-150 seconds	
Peak Temperature(T _P)	225+0/-5°C	240+0/-5°C	245+0/-5°C	250+0/-5°C
Time within 5°C of actual Peak Temperature (t _p)	10-30 seconds	10-30 seconds	10-30 seconds	20-40 seconds
Ramp-down Rate	6°C/second max.		3°C/second max.	
Time 25°C to Peak Temperature	6 minutes max.		8 minutes max.	

*All temperatures refer to topside of the package, measured on the package body surface.

7F, No.9, PARK AVENUE II, Science-Based Industrial Park, Hsinchu 300, Taiwan, R.O.C.

Tel: 886-3-563-0878

Fax: 886-3-563-0879

 WWW: <http://www.aimtron.com.tw>

2/15/2006 REV : 1.1

 Email: service@aimtron.com.tw