



MicroConverter, Dual 16-Bit/24-Bit ADCs with Embedded 62kB FLASH MCU

Preliminary Technical Data

ADuC844

FEATURES

High Resolution Sigma-Delta ADCs

- Two Independent ADCs (24-Bit and 16-Bit Resolution)
- 24-Bit No Missing Codes, Primary ADC
- 21-Bit rms (18.5 Bit p-p) Effective Resolution @ 20 Hz
- Offset Drift 10 nV/°C, Gain Drift 0.5 ppm/°C

Memory

- 62 Kbytes On-Chip Flash/EE Program Memory
- 4 Kbytes On-Chip Flash/EE Data Memory
- Flash/EE, 100 Year Retention, 100 Kcycles Endurance
- 3 Levels of Flash/EE Program Memory Security
- In-Circuit Serial Download (No External Hardware)
- High Speed User Download (5 Seconds)
- 2304 Bytes On-Chip Data RAM

8051-Based Core

- 8051 Compatible Instruction Set
- High Performance Single Cycle Core
- 32 kHz External Crystal
- On-Chip Programmable PLL (12.58 MHz Max)
- 3 × 16-Bit Timer/Counter
- 26 Programmable I/O Lines
- 11 Interrupt Sources, Two Priority Levels
- Dual Data Pointer, Extended 11-Bit Stack Pointer

On-Chip Peripherals

- Internal Power on Reset Circuit
- 12-Bit Voltage Output DAC
- Dual 16-Bit S-D DACs/PWMs
- On-Chip Temperature Sensor
- Dual Excitation Current Sources
- Time Interval Counter (Wakeup/RTC Timer)
- UART, SPI®, and I²C® Serial I/O
- High Speed Baud Rate Generator (incl 115,200)
- Watchdog Timer (WDT)
- Power Supply Monitor (PSM)

Power

- Normal: 2.3mA Max @ 3.6 V (Core CLK = 1.57 MHz)
- Power-Down: 20mA Max with Wakeup Timer Running
- Specified for 3 V and 5 V Operation

Package and Temperature Range

- 52-Lead MQFP (14 mm × 14 mm), -40°C to +125°C
- 56-Lead CSP (8 mm × 8 mm), -40°C to +85°C

APPLICATIONS

- Intelligent Sensors
- WeighScales
- Portable Instrumentation, Battery Powered Systems
- 4-20mA Transmitters
- Data Logging
- Precision System Monitoring

REV. PrB

Information furnished by Analog Devices is believed to be accurate and reliable. However, no responsibility is assumed by Analog Devices for its use, nor for any infringements of patents or other rights of third parties that may result from its use. No license is granted by implication or otherwise under any patent or patent rights of Analog Devices. Trademarks and registered trademarks are the property of their respective companies.

FUNCTIONAL BLOCK DIAGRAM

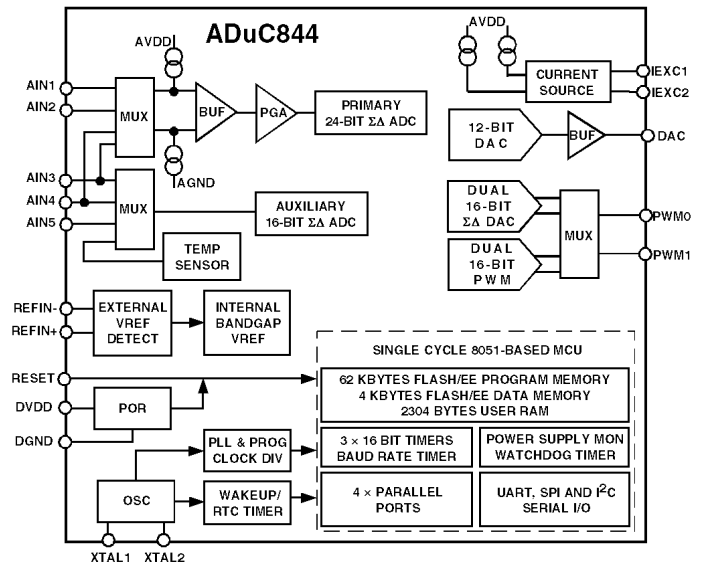

GENERAL DESCRIPTION

The ADuC844 is a complete smart transducer front end, integrating two high resolution sigma-delta ADCs, an 8-bit MCU, and program/data Flash/EE memory on a single chip.

The two independent ADCs (primary and auxiliary) include a temperature sensor and a PGA (allowing direct measurement of low level signals). The ADCs with on-chip digital filtering and programmable output data rates are intended for the measurement of wide dynamic range, low frequency signals, such as those in weigh scale, strain-gage, pressure transducer, or temperature measurement applications.

The device operates from a 32 kHz crystal with an on-chip PLL generating a high frequency clock of 12.58 MHz. This clock is routed through a programmable clock divider from which the MCU core clock operating frequency is generated. The microcontroller core is an optimized single cycle 8051 offering up to 12.58MIPS performance while maintaining the 8051 instruction set compatibility.

62 Kbytes of nonvolatile Flash/EE program memory, 4 Kbytes of nonvolatile Flash/EE data memory, and 2304 bytes of data RAM are provided on-chip. The program memory can be configured as data memory to give up to 60 Kbytes of NV data memory in data logging applications.

On-chip factory firmware supports in-circuit serial download and debug modes (via UART), as well as single-pin emulation mode via the EA pin. The ADuC844 is supported by a QuickStart™ development system featuring low cost software and hardware development tools.

One Technology Way, P.O. Box 9106, Norwood, MA 02062-9106, U.S.A.

Tel: 781/329-4700

www.analog.com

Fax: 781/326-8703

© 2003 Analog Devices, Inc. All rights reserved.

PRELIMINARY TECHNICAL DATA

ADuC844 SPECIFICATIONS¹

(AVDD = 2.7 V to 3.6 V or 4.75 V to 5.25 V, DVDD = 2.7 V to 3.6 V or 4.75 V to 5.25 V, REFIN(+) = 2.5 V, REFIN(-) = AGND; AGND = DGND = 0 V; XTAL1/XTAL2 = 32.768 kHz Crystal; all specifications T_{MIN}, to T_{MAX} unless otherwise noted.)

PARAMETER	MIN	TYP	MAX	UNITS	CONDITION
PRIMARY ADC					
Conversion Rate	5.35	19.79	105	Hz	On Both Channels
No Missing Codes ²	24			Bits	19.79Hz Update Rate
Resolution		13.5		Bits Pk-Pk	Range = ± 20mV, 20Hz Update Rate
		18.5		Bits Pk-Pk	Range = ± 2.56V, 20Hz Update Rate
Output Noise	See Tables X and XI in ADC Description				Output Noise varies with selected Update Rates and Gain Range
Integral Non Linearity			± 15	ppm of FSR	1 LSB ₁₆
Offset Error ³		± 3		μV	
Offset Error Drift (vs. Temp)		± 10		nV/°C	
Full-Scale Error ⁴		± 10		μV	
Gain Error Drift ⁵ (vs. Temp)		± 0.5		ppm/°C	
ADC Range Matching		± 2		μV	AIN=18mV
Power Supply Rejection	80			dBs	AIN=1V, Range=± 2.56V
		113		dBs	AIN=7.8mV, Range=± 20mV
Common Mode DC Rejection					
On AIN	95			dBs	@DC, AIN=7.8mV, Range=± 20mV
On AIN		113		dBs	@DC, AIN=1V, Range=± 2.56V
Common Mode 50/60Hz Rejection					20 Hz Update Rate
On AIN	95			dBs	50/60Hz ± 1Hz, AIN=7.8mV, Range=± 20mV
On AIN	90			dBs	50/60Hz ± 1Hz, AIN=1V, Range=± 2.56V
Normal Mode 50/60 Hz Rejection					
On AIN	60			dBs	50/60Hz ± 1Hz, 20 Hz Update Rate
PRIMARY ADC ANALOG INPUTS					
Differential Input Voltage Ranges ^{9,10}					
Bipolar Mode (ADC0CON.5 = 0)	± 1.024 x V _{REF} /GAIN			V	V _{REF} = REFIN(+) - REFIN(-) (or Int 1.25V Ref) GAIN = 1 to 128
Unipolar Mode (ADC0CON.5 = 1)	0 → 1.024 x REFIN/GAIN			V	V _{REF} = REFIN(+) - REFIN(-) GAIN=1 to 128
Analog Input Current ²			± 1	nA	T _{MAX} = 85°C
			± 5	nA	T _{MAX} = 125°C
Analog Input Current Drift		± 5		pA/°C	T _{MAX} = 85°C
		± 15		pA/°C	T _{MAX} = 125°C
Absolute AIN Voltage Limits ²	A _{GND} + 0.1		AV _{DD} - 0.1	V	
EXTERNAL REFERENCE INPUTS					
REFIN(+) to REFIN(-) Range ²	1	2.5	AV _{DD}	V	
Average Reference Input Current		+/- 1		μA/V	Both ADCs Enabled
Average Reference Input Current Drift		+/- 0.01		nA/V/°C	
'NO Ext. REF' Trigger Voltage	0.3		0.65	V	NOXREF bit active if VREF<0.3V NOXREF bit Inactive if VREF>0.65
Common Mode DC Rejection	125			dBs	@DC, AIN=1V, Range=± 2.56V
Common Mode 50/60Hz Rejection	90			dBs	50/60Hz ± 1Hz, AIN=1V, Range=± 2.56V
Normal Mode 50/60 Hz Rejection	60			dBs	50/60Hz ± 1Hz, 59.4 Hz Update Rate

PARAMETER	MIN	TYP	MAX	UNITS	CONDITION
AUXILIARY ADC					
No Missing Codes ²	16			Bits	20 Hz Update Rate
Resolution		16		Bits Pk-Pk	Range = ± 2.5V, 20Hz Update Rate
Output Noise		See Table XII			Output Noise varies with selected Update Rates
Integral Non Linearity			± 15	ppm of FSR	1 LSB ₁₆
Offset Error ³		-2		LSB	
Offset Error Drift		1		µV /°C	
Fullscale Error ⁴		-2.5		LSBs	
Gain Error Drift ⁵		± 0.5		ppm/°C	
Power Supply Rejection	80			dBs	AIN=1V, Range=± 2.56V
Normal Mode 50/60 Hz Rejection					
On AIN	60			dBs	50/60Hz ± 1Hz, 19.79Hz Update Rate
On REFIN	60			dBs	50/60Hz ± 1Hz, 19.79Hz Update Rate
AUXILIARY ADC ANALOG INPUTS					
Differential Input Voltage Ranges ^{9, 10} (Bipolar Mode – ADC0CON3 = 0) (Unipolar Mode – ADC0CON3 = 1)		± REFIN		V	REFIN=REFIN(+)-REFIN(-) (or Int 1.25V Ref)
Average Analog Input Current		0 → REFIN		V	REFIN=REFIN(+)-REFIN(-) (or Int 1.25V Ref)
Analogue Input Current Drift		125		nA/V	
Absolute AIN Voltage Limits ^{2, 11}		± 2		pA/V/°C	
	A _{GN} D - 0.03		A _V DD + 0.03	V	
ADC SYSTEM CALIBRATION					
Full Scale Calibration Limit			+1.05 x FS	V	
Zero Scale Calibration Limit	-1.05 x FS			V	
Input Span	0.8 x FS		2.1 x FS	V	
DAC					
Voltage Range		0 → V _{REF} 0 → AV _{DD}		V	DACCON.2 = 0
Resistive Load		10		kΩ	DACCON.2 = 1
Capacitive Load		100		pF	From DAC Output to AGND
Output Impedance		0.5		Ω	From DAC Output to AGND
I _{SINK}		50		µA	
DC Specifications⁷					
Resolution	12			LSBs	
Relative Accuracy		± 3		LSBs	
Differential NonLinearity			-1	Bit	Guaranteed 12-Bit Monotonic
Offset Error			± 50	mV	
Gain Error ⁸			± 1	%	AV _{DD} Range
		± 1		%	V _{REF} Range
AC Specifications^{2,7}					
Voltage Output Settling Time		15		us	Settling time to 1LSB of final value
Digital to Analog Glitch Energy		10		nVs	1 LSB change at major carry

PRELIMINARY TECHNICAL DATA

ADuC844 SPECIFICATIONS¹

PARAMETER	MIN	TYP	MAX	UNITS	CONDITION
INT REFERENCE					
ADC Reference					
Reference Voltage	1.237	1.25	1.2625	V	initial tolerance @ 25°C, VDD=5V
Power Supply Rejection		45		dBs	
Reference Tempco		100		ppm/°C	
DAC Reference					
Reference Voltage	2.475	2.5	1.525	V	initial tolerance @ 25°C, VDD=5V
Power Supply Rejection		50		dBs	
Reference Tempco		± 100		ppm/°C	
TEMPERATURE SENSOR					
Accuracy		+/- 2		°C	MQFP Package CSP Package
Thermal Impedance		90		°C/W	
		52		°C/W	
TRANSDUCER BURNOUT CURRENT SOURCES					
AIN+ Current		-100		nA	AIN+ is the selected positive input to the primary ADC AIN- is the selected negative input to the primary ADC
AIN- Current		100		nA	
Initial Tolerance at 25°C		+/- 10		%	
Drift		0.03		%/°C	
EXCITATION CURRENT SOURCES					
Output Current		-200		μA	Available from each Current Source
Initial Tolerance at 25°C		+/-10		%	
Drift		200		ppm/°C	Matching between both Current Sources
Initial Current Matching at 25°C		+/-1		%	
Drift Matching		20		ppm/°C	
Line Regulation (AV _{DD})		1		μA/V	
Load Regulation			0.1	V	AV _{DD} =5V +/- 5%
Output Compliance	A _{GND}		AV _{DD} -0.6	V	
POWER SUPPLY MONITOR (PSM)					
AV _{DD} Trip Point Selection Range	2.63		4.63	V	Four Trip Points selectable in this range T _{MAX} = 85°C
AV _{DD} Trip Point Accuracy			+/- 3.0	%	
AV _{DD} Trip Point Accuracy			+/- 3.0	%	Four Trip Points selectable in this range T _{MAX} = 125°C
DV _{DD} Trip Point Selection Range	2.63		4.63	V	
DV _{DD} Trip Point Accuracy			+/- 3.0	%	
DV _{DD} Trip Point Accuracy			+/- 3.0	%	
CRYSTAL OSCILLATOR (XTAL 1AND XTAL2)					
Logic Inputs, XTAL1 Only ²					
V _{INL} , Input Low Voltage			0.8	V	DV _{DD} = 5V DV _{DD} = 3V DV _{DD} = 5V DV _{DD} = 3V
			0.4	V	
V _{INH} , Input Low Voltage	3.5			V	
	2.5			V	
XTAL1 Input Capacitance		18		pF	
XTAL2 Output Capacitance		18		pF	

PARAMETER	MIN	TYP	MAX	UNITS	CONDITION
LOGIC INPUTS					
All Inputs except SCLOCK, RESET and XTAL1 ²					
V _{INL} , Input Low Voltage			0.8	V	DV _{DD} = 5V
			0.4	V	DV _{DD} = 3V
V _{INH} , Input Low Voltage SCLOCK and RESET Only (Schmidt Triggered Inputs) ²	2.0			V	
V _{T+}	1.3		3.0	V	DV _{DD} = 5V
	0.95		2.5	V	DV _{DD} = 3V
V _{T-}	0.8		1.4	V	DV _{DD} = 5V
	0.4		1.1	V	DV _{DD} = 3V
V _{T+} - V _{T-}	0.3		0.85	V	DV _{DD} = 5V or 3V
Input Currents	2.0			V	
Port 0, P1.2→P1.7, \overline{EA}			+/- 10	μA	V _{IN} = 0V or V _{DD}
SCLOCK, MOSI, MISO \overline{SS} ¹³	-10		-40	μA	V _{IN} = 0V, DV _{DD} =5V, Internal Pullup
			+/-10	μA	V _{IN} = DV _{DD} , DV _{DD} =5V
RESET			+/-10	μA	V _{IN} = 0V, DV _{DD} =5V
	35		105	μA	V _{IN} = DV _{DD} , DV _{DD} =5V, Internal Pull-Down
P1.0, P1.1, Port 2, Port 3			+/-10	μA	V _{IN} = DV _{DD} , DV _{DD} =5V
	-180		-660	μA	V _{IN} = 2V, DV _{DD} =5V
	-20		-75	μA	V _{IN} = 0.45V, DV _{DD} =5V
Input Capacitance		5		pF	All Digital Inputs
LOGIC OUTPUTS					
All Digital Outputs except XTAL2 ²					
V _{OH} , Output High Voltage	2.4			V	DV _{DD} = 5V, I _{SOURCE} = 80 μA
	2.4			V	DV _{DD} = 3V, I _{SOURCE} = 20 μA
V _{OL} , Output Low Voltage ¹⁴			0.8	V	I _{SINK} = 8mA, SCLOCK, MOSI/SDATA
			0.8	V	I _{SINK} = 10mA, P1.0, P1.1
			0.8	V	I _{SINK} = 1.6mA, All Other Outputs
Floating State Leakage Current			+/-10	μA	
Floating State Output Capacitance		5		pF	
START UP TIME					
At Power On		300		ms	
After External RESET in Normal Mode		3		ms	
After WDT RESET in Normal Mode		3		ms	Controlled via WDCON SFR
From Idle Mode		10		us	
From Power-Down Mode					
Oscillator Running					PLLCON.7 = 0
Wakeup with INT0 Interrupt		20		us	
Wakeup with SPI Interrupt		20		us	
Wakeup with TIC Interrupt		20		us	
Wakeup with External RESET		3		us	
Oscillator Powered Down					PLLCON.7 = 1
Wakeup with INT0 Interrupt		20		us	
Wakeup with SPI Interrupt		20		us	
Wakeup with External RESET		5		ms	

PRELIMINARY TECHNICAL DATA

ADuC844 SPECIFICATIONS¹

PARAMETER	MIN	TYP	MAX	UNITS	CONDITION
FLAH/EE MEMORY RELIABILITY CHARACTERISTICS					
Endurance ¹⁶	100,000	700,000		Cycles	
Data Retention ¹⁷	100				
POWER REQUIREMENTS					
Power Supply Voltages					
AV _{DD} 3V Nominal	2.7		3.6	V	
AV _{DD} 5V Nominal	4.75		5.25	V	
DV _{DD} 3V Nominal	2.7		3.6	V	
DV _{DD} 5V Nominal	4.75		5.25	V	
5V POWER CONSUMPTION					
Normal Mode ^{18, 19}					
DV _{DD} Current			4	mA	4.75V < DVDD < 5.25V, AVDD= 5.25V
AV _{DD} Current		13	16	mA	core clock = 1.57MHz
Power-Down Mode ^{18, 19}			180	μA	core clock = 12.58MHz
DV _{DD} Current			53	μA	T _{MAX} = 85°C; Osc ON; TIC ON
			100	μA	T _{MAX} = 125°C; Osc ON; TIC ON
DV _{DD} Current			30	μA	T _{MAX} = 85°C; Osc OFF
			80	μA	T _{MAX} = 125°C; Osc OFF
AV _{DD} Current			1	μA	T _{MAX} = 85°C; Osc ON or OFF
			3	μA	T _{MAX} = 125°C; Osc ON or OFF
Typical Additional Peripheral Currents (AI _{DD} and D I _{DD})					
Primary ADC		1		mA	
Auxiliary ADC		0.5		mA	
Power Supply Monitor		50		μA	
DAC		150		μA	
Dual Excitation Current Sources		400		μA	
3V POWER CONSUMPTION					
Normal Mode ^{18, 19}					
DV _{DD} Current			2.3	mA	4.75V < DVDD < 5.25V, AVDD= 5.25V
AV _{DD} Current		8	10	mA	core clock = 1.57MHz
Power-Down Mode ^{18, 19}			180	μA	core clock = 12.58MHz
DV _{DD} Current			20	μA	T _{MAX} = 85°C; Osc ON; TIC ON
			40	μA	T _{MAX} = 125°C; Osc ON; TIC ON
DV _{DD} Current		10		μA	Osc OFF
			80	μA	T _{MAX} = 125°C; Osc OFF
AV _{DD} Current			1	μA	T _{MAX} = 85°C; Osc ON or OFF
			3	μA	T _{MAX} = 125°C; Osc ON or OFF

NOTES

- 1 Temperature Range for ADuC844BS (MQFP package) is -40°C to $+125^{\circ}\text{C}$.
Temperature Range for ADuC844BCP (CSP package) is -40°C to $+85^{\circ}\text{C}$.
- 2 These numbers are not production tested but are guaranteed by design and/or characterization data on production release.
- 3 System Zero-Scale Calibration can remove this error.
- 4 The primary ADC is factory calibrated at 25°C with $\text{AVDD} = \text{DVDD} = 5\text{ V}$ yielding this full-scale error of 10 V. If user power supply or temperature conditions are significantly different from these, an Internal Full-Scale Calibration will restore this error to 10 V. A system zero-scale and full-scale calibration will remove this error altogether.
- 5 Gain Error Drift is a span drift. To calculate Full-Scale Error Drift, add the Offset Error Drift to the Gain Error Drift times the full-scale input.
- 6 The auxiliary ADC is factory calibrated at 25°C with $\text{AVDD} = \text{DVDD} = 5\text{ V}$ yielding this full-scale error of -2.5 LSB . A system zero-scale and full-scale calibration will remove this error altogether.
- 7 DAC linearity and ac specifications are calculated using: reduced code range of 48 to 4095, 0 to VREF, reduced code range of 100 to 3950, 0 to VDD.
- 8 Gain Error is a measure of the span error of the DAC.
- 9 In general terms, the bipolar input voltage range to the primary ADC is given by $\text{RangeADC} = \pm(\text{VREF} \cdot 2^{\text{RN}})/125$, where:
VREF = REFIN(+) to REFIN(-) voltage and VREF = 1.25 V when internal ADC VREF is selected.
RN = decimal equivalent of RN2, RN1, RN0
e.g., VREF = 2.5 V and RN2, RN1, RN0 = 1, 1, 0 the $\text{RangeADC} = \pm 1.28\text{ V}$. In unipolar mode, the effective range is 0 V to 1.28 V in our example.
- 10 1.25 V is used as the reference voltage to the ADC when internal VREF is selected via XREF0 and XREF1 bits in ADC0CON and ADC1CON, respectively.
- 11 In bipolar mode, the Auxiliary ADC can only be driven to a minimum of $\text{AGND} - 30\text{ mV}$ as indicated by the Auxiliary ADC absolute AIN voltage limits. The bipolar range is still $-\text{VREF}$ to $+\text{VREF}$; however, the negative voltage is limited to -30 mV .
- 12 The ADuC844BCP (CSP Package) has been qualified and tested with the base of the CSP Package floating.
- 13 Pins configured in SPI Mode, pins configured as digital inputs during this test.
- 14 Pins configured in I²C Mode only.
- 15 Flash/EE Memory Reliability Characteristics apply to both the Flash/EE program memory and Flash/EE data memory.
- 16 Endurance is qualified to 100 Kcycles as per JEDEC Std. 22 method A117 and measured at -40°C , $+25^{\circ}\text{C}$, $+85^{\circ}\text{C}$, and $+125^{\circ}\text{C}$. Typical endurance at 25°C is 700 Kcycles.
- 17 Retention lifetime equivalent at junction temperature (TJ) = 55°C as per JEDEC Std. 22, Method A117. Retention lifetime based on an activation energy of 0.6eV will derate with junction temperature as shown in Figure 16 in the Flash/EE Memory section of this data sheet.
- 18 Power Supply current consumption is measured in Normal, Idle, and Power-Down Modes under the following conditions:
Normal Mode: Reset = 0.4 V, Digital I/O pins = open circuit, Core Clk changed via CD bits in PLLCON, Core Executing internal software loop.
Idle Mode: Reset = 0.4 V, Digital I/O pins = open circuit, Core Clk changed via CD bits in PLLCON, PCON.0 = 1, Core Execution suspended in idle mode.
Power-Down Mode: Reset = 0.4 V, All P0 pins and P1.2–P1.7 Pins = 0.4 V, All other digital I/O pins are open circuit, Core Clk changed via CD bits in PLLCON, PCON.1 = 1, Core Execution suspended in power-down mode, OSC turned ON or OFF via OSC_PD bit (PLLCON.7) in PLLCON SFR.
- 19 DVDD power supply current will increase typically by 3 mA (3 V operation) and 10 mA (5 V operation) during a Flash/EE memory program or erase cycle.

Specifications subject to change without notice

PRELIMINARY TECHNICAL DATA

ADuC844

ABSOLUTE MAXIMUM RATINGS

(TA = 25°C unless otherwise noted)

AVDD to AGND	-0.3 V to +7 V
AVDD to DGND	-0.3 V to +7 V
DVDD to AGND	-0.3 V to +7 V
DVDD to DGND	-0.3 V to +7 V
AGND to DGND ²	-0.3 V to +0.3 V
AVDD to DVDD	-2 V to +5 V
Analog Input Voltage to AGND ³	-0.3 V to AVDD +0.3 V
Reference Input Voltage to AGND	-0.3 V to AVDD +0.3 V
AIN/REFIN Current (Indefinite)	30 mA
Digital Input Voltage to DGND	-0.3 V to DVDD +0.3 V
Digital Output Voltage to DGND	-0.3 V to DVDD +0.3 V
Operating Temperature Range	-40°C to +125°C
Storage Temperature Range	-65°C to +150°C
Junction Temperature	150°C
θJA Thermal Impedance	90°C/W
Lead Temperature, Soldering	
Vapor Phase (60 sec)	215°C
Infrared (15 sec)	220°C

¹Stresses above those listed under Absolute Maximum Ratings may cause permanent damage to the device. This is a stress rating only; functional operation of the device at these or any other conditions above those listed in the operational sections of this specification is not implied. Exposure to absolute maximum rating conditions for extended periods may affect device reliability.

²AGND and DGND are shorted internally on the ADuC844.

³Applies to P1.2 to P1.7 pins operating in analog or digital input modes.

PIN CONFIGURATION

52-Lead MQFP

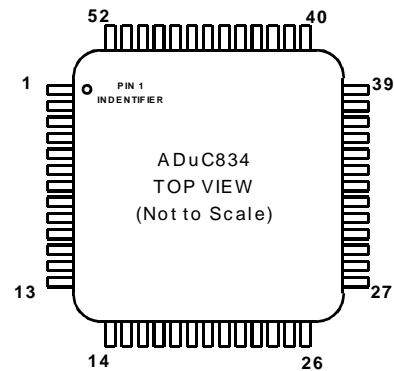

56-Lead CSP

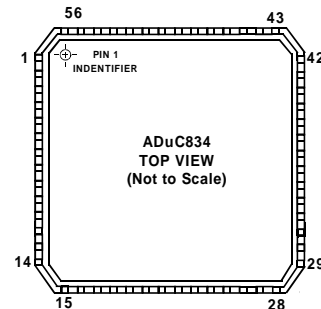

ORDERING GUIDE

MODEL	Temperature Range (°C)	Voltage Range (V)	User Code Space	Package Description	Package Option
ADuC844BS62-5	-40 → +125	4.75 → 5.25	62 kBytes	52-Lead Plastic Quad Flatpack	S-52
ADuC844BS62-3	-40 → +125	2.75 → 3.60	62 kBytes	52-Lead Plastic Quad Flatpack	S-52
ADuC844BCP62-5	-40 → +125	4.75 → 5.25	62 kBytes	56-Lead Chip Scale Package	S-52
ADuC844BCP62-3	-40 → +125	2.75 → 3.60	62 kBytes	56-Lead Chip Scale Package	S-52
ADuC844BCP32-5	-40 → +125	4.75 → 5.25	32 kBytes	56-Lead Chip Scale Package	S-52
ADuC844BCP32-3	-40 → +125	2.75 → 3.60	32 kBytes	56-Lead Chip Scale Package	S-52
ADuC844BCP8-5	-40 → +125	4.75 → 5.25	8 kBytes	56-Lead Chip Scale Package	S-52
ADuC844BCP8-3	-40 → +125	2.75 → 3.60	8 kBytes	56-Lead Chip Scale Package	S-52
EVAL-ADuC844QS				QuickStart Development System	
EVAL-ADuC844QS				QuickStart Plus Development System	

CAUTION

ESD (electrostatic discharge) sensitive device. Electrostatic charges as high as 4000V readily accumulate on the human body and test equipment and can discharge without detection. Although the ADuC844 features proprietary ESD protection circuitry, permanent damage may occur on devices subjected to high-energy electrostatic discharges. Therefore, proper ESD precautions are recommended to avoid performance degradation or loss of functionality.



PIN FUNCTION DESCRIPTIONS

Pin No: 52-MQFP	Pin No: 56-CSP	Pin Mnemonic	Type*	Description
1, 2	56, 1	P1.0/P1.1	I/O	P1.0 and P1.1 can function as a digital inputs or digital outputs and have a pull-up configuration as described below for Port 3. P1.0 and P1.1 have an increased current drive sink capability of 10mA.
		P1.0/T2/PWM0	I/O	P1.0 and P1.1 also have various secondary functions as described below. P1.0 can also be used to provide a clock input to Timer 2. When enabled, counter 2 is incremented in response to a negative transition on the T2 input pin. If the PWM is enabled, the PWM0 output will appear at this pin.
		P1.1/T2EX/PWM1	I/O	P1.1 can also be used to provide a control input to Timer 2. When enabled, a negative transition on the T2EX input pin will cause a Timer 2 capture or reload event. If the PWM is enabled, the PWM1 output will appear at this pin.
3 → 4 9 → 12	2 → 3 11 → 14	P1.2 → P1.7	I	Port 1.2 to Port 1.7 have no digital output driver; they can function as a digital input for which '0' must be written to the port bit. As a digital input, these pins must be driven high or low externally. These pins also have the following analog functionality:
		P1.2/DAC/IEXC1	I/O	The voltage output from the DAC or one or both current sources (200 uA or 2 x 200 uA) can be configured to appear at this pin.
		P1.3/AIN5/IEXC2	I/O	Auxiliary ADC Input or one or both current sources can be configured at this pin.
		P1.4/AIN1	I	Primary ADC, Positive Analog Input
		P1.5/AIN2	I	Primary ADC, Negative Analog Input
		P1.6/AIN3	I	Auxiliary ADC Input or Muxed Primary ADC, Positive Analog Input
		P1.7/AIN4/DAC	I/O	Auxiliary ADC Input or Muxed Primary ADC, Negative Analog Input. The voltage
5	4	AVDD	S	Analog Supply Voltage
6	5	AGND	S	Analog Ground.
N/C	6	AGND	S	A second Analog ground is provided with the CSP version only.
7	7	REFIN-	I	External Reference Input, negative terminal
8	8	REFIN+	I	External Reference Input, positive terminal
13	15	\overline{SS}	I	The slave select input for the SPI Interface is present at this pin. A weak pull-up is present on this pin.
14	16	MISO	I	Master Input/Slave Output for the SPI Interface. There is a weak pull-up on this input pin.
15	17	RESET	I	Reset Input. A high level on this pin for 16 core clock cycles while the oscillator is running resets the device. There is an internal weak pull-down and a Schmitt trigger input stage on this pin.

PRELIMINARY TECHNICAL DATA

ADuC844

Pin No: 52-MQFP	Pin No: 56-CSP	Pin Mnemonic	Type*	Description
16-19 22-25	18-21 24-27	P3.0 → P3.7	I/O	<p>P3.0–P3.7 are bi-directional port pins with internal pull-up resistors. Port 3 pins that have 1s written to them are pulled high by the internal pull-up resistors, and in that state can be used as inputs. As inputs, Port 3 pins being pulled externally low will source current because of the internal pull-up resistors. When driving a 0-to-1 output transition, a strong pull-up is active for two core clock periods of the instruction cycle.</p> <p>Port 3 pins also have various secondary functions described below.</p>
16	18	P3.0/RXD		Receiver Data for UART serial Port
17	19	P3.1/TXD		Transmitter Data for UART serial Port
18	20	P3.2/INT0		External Interrupt 0. This pin can also be used as a gate control input to Timer0.
19	21	P3.3/INT1		External Interrupt 1. This pin can also be used as a gate control input to Timer1.
22	24	P3.4/T0/PWMCLK		<p>Timer/Counter 0 External Input</p> <p>If the PWM is enabled, an external clock may be input at this pin.</p>
23	25	P3.5/T1		Timer/Counter 1 External Input
24	26	P3.6/WR		External Data Memory Write Strobe. Latches the data byte from Port 0 into an external data memory.
25	27	P3.7/RD		External Data Memory Read Strobe. Enables the data from an external data memory to Port 0.
20, 34, 48 21, 35, 47	22, 36, 51 23, 37, 50	DVDD DGND	S S	Digital Supply Voltage Digital Ground.
26	28	SCLOCK	I/O	Serial interface clock for either the I ² C or SPI interface. As an input, this pin is a Schmitt-triggered input and a weak internal pull-up is present on this pin unless it is outputting logic low. This pin can also be directly controlled in software as a digital output pin.
27	29	MOSI/SDATA	I/O	Serial Data I/O for the I ² C Interface or Master Output/Slave Input for the SPI Interface. A weak internal pull-up is present on this pin unless it is outputting logic low. This pin can also be directly controlled in software as a digital output pin.
28 → 31 36 → 39	30 → 32 38 → 42	P2.0 → P2.7	I/O	<p>Port 2 is a bidirectional port with internal pull-up resistors. Port 2 pins that have 1s written to them are pulled high by the internal pull-up resistors, and in that state can be used as inputs. As inputs, Port 2 pins being pulled externally low will source current because of the internal pull-up resistors.</p> <p>Port 2 emits the high order address bytes during fetches from external program memory and middle and high order address bytes during accesses to the 24-bit external data memory space.</p>
32	34	XTAL1	I	Input to the crystal oscillator inverter.
33	35	XTAL2	O	Output from the crystal oscillator inverter. (see “Hardware Design Considerations” for description)
40	43	\overline{EA}		<p>External Access Enable, Logic Input. When held high, this input enables the device to fetch code from internal program memory locations 0000h to F7FFh. When held low this input enables the device to fetch all instructions from external program memory. To determine the mode of code execution, i.e., internal or external, the \overline{EA} pin is sampled at the end of an external RESET assertion or as part of a device power cycle.</p> <p>\overline{EA} may also be used as an external emulation I/O pin and therefore the voltage level at this pin must not be changed during normal mode operation as it may cause an emulation interrupt that will halt code execution.</p>

PRELIMINARY TECHNICAL DATA

ADuC844

Pin No: 52-MQFP	Pin No: 56-CSP	Pin Mnemonic	Type*	Description
41	44	PSEN		Program Store Enable, Logic Output. This output is a control signal that enables the external program memory to the bus during external fetch operations. It is active every six oscillator periods except during external data memory accesses. This pin remains high during internal program execution. PSEN can also be used to enable serial download mode when pulled low through a resistor at the end of an external RESET assertion or as part of a device power cycle.
42	45	ALE		Address Latch Enable, Logic Output. This output is used to latch the low byte (and page byte for 24-bit data address space accesses) of the address to external memory during external code or data memory access cycles. It is activated every six oscillator periods except during an external data memory access. It can be disabled by setting the PCON.4 bit in the PCON SFR.
43 → 46 49 → 52	46 → 49 52 → 55	P0.0 → P0.7	I/O	P0.0–P0.7, these pins are part of Port0 which is an 8-bit open-drain bidirectional I/O port. Port 0 pins that have 1s written to them float and in that state can be used as high impedance inputs. An external pull-up resistor will be required on P0 outputs to force a valid logic high level externally. Port 0 is also the multiplexed low-order address and data bus during accesses to external program or data memory. In this application it uses strong internal pull-ups when emitting 1s.

*I = Input, O = Output, S = Supply.

ADuC844

DETAILED BLOCK DIAGRAM WITH PIN NUMBERS

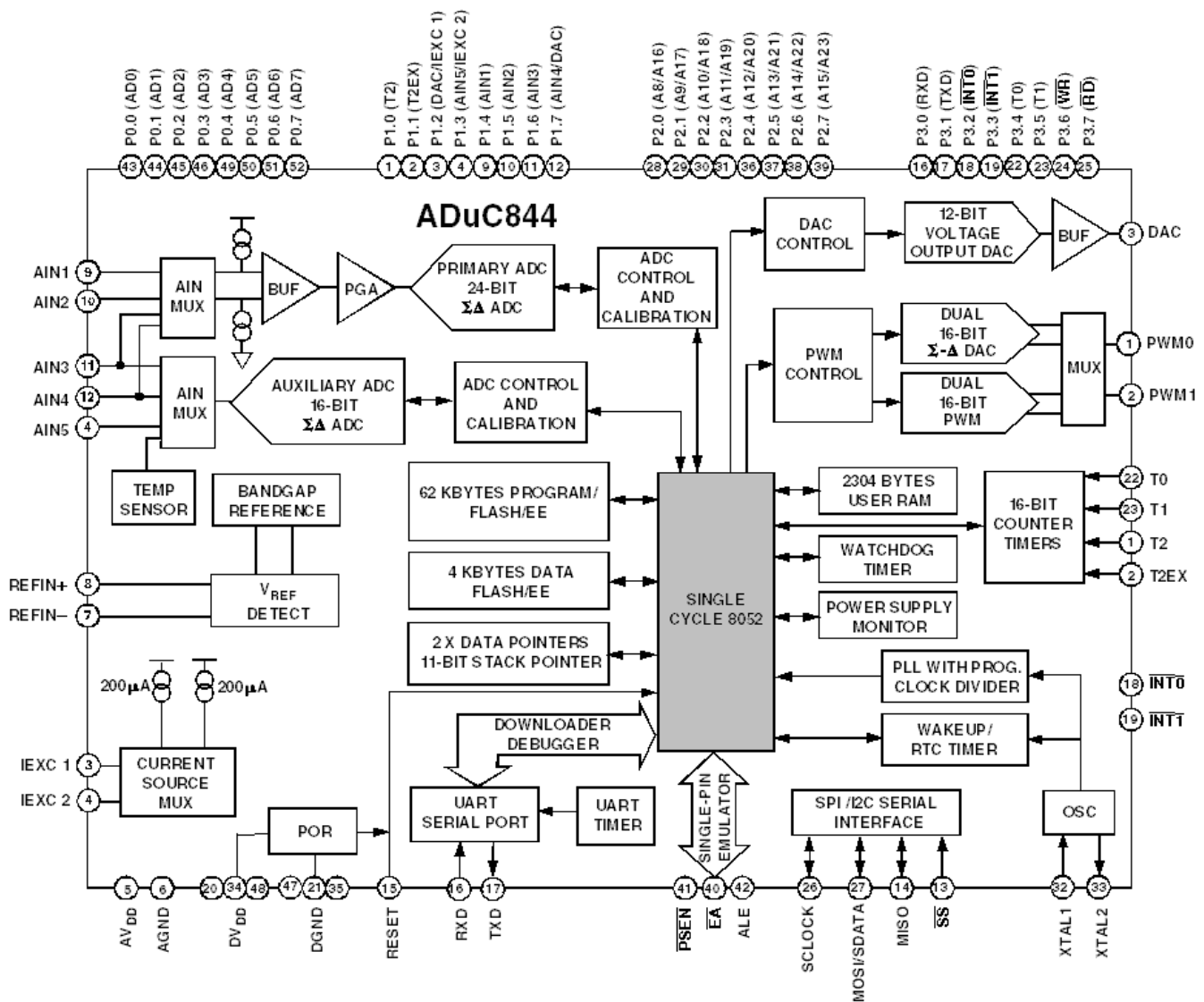

PIN NUMBERS REFER TO THE 52 PIN MQFP PACKAGE*
 SHADED AREAS REPRESENT THE NEW FEATURES OF THE ADuC844 OVER THE ADuC834

Figure 1: Detailed Block Diagram of the ADuC844

MEMORY ORGANISATION

The ADuC844 contains 4 different memory blocks namely:

- 62kBytes of On-Chip Flash/EE Program Memory
- 4kBytes of On-Chip Flash/EE Data Memory
- 256 Bytes of General Purpose RAM
- 2kBytes of Internal XRAM

(1) Flash/EE Program Memory

The ADuC844 provides 62kBytes of Flash/EE program memory to run user code. The user can choose to run code from this internal memory or run code from an external program memory. If the user applies power or resets the device while the \overline{EA} pin is pulled low externally, the part will execute code from the external program space, otherwise if \overline{EA} is pulled high externally the part defaults to code execution from its internal 62kBytes of Flash/EE program memory. The ADuC844 does not support the rollover from F7FFh in internal code space to F800h in external code space. Instead the 2048 bytes between F800h and FFFFh will appear as NOP instructions to user code.

Permanently embedded firmware allows code to be serially downloaded to the 62kBytes of internal code space via the UART serial port while the device is in-circuit. No external hardware is required.

56kBytes of the program memory can be reprogrammed during runtime hence the code space can be upgraded in the field using a user defined protocol or it can be used as a data memory. This will be discussed in more detail in the Flash/EE Memory section of the datasheet.

(2) Flash/EE Data Memory

4kBytes of Flash/EE Data Memory are available to the user and can be accessed indirectly via a group of registers mapped into the Special Function Register (SFR) area. Access to the Flash/EE Data memory is discussed in detail later as part of the Flash/EE memory section in this data sheet.

(3) General Purpose RAM

The general purpose RAM is divided into two separate memories, namely the upper and the lower 128 bytes of RAM. The lower 128 bytes of RAM can be accessed through direct or indirect addressing while the upper 128 bytes of RAM can only be accessed through indirect addressing as it shares the same address space as the SFR space which can only be accessed through direct addressing.

The lower 128 bytes of internal data memory are mapped as shown in Figure 2. The lowest 32 bytes are grouped into four banks of eight registers addressed as R0 through R7. The next 16 bytes (128 bits), locations 20Hex through 2FHex above the register banks, form a block of directly addressable bit locations at bit addresses 00H through 7FH. The stack can be located anywhere in the internal memory address space, and the stack depth can be expanded up to 2048 bytes.

Reset initializes the stack pointer to location 07 hex. Any call or push pre-increments the SP before loading the stack. Hence loading the stack starts from locations 08 hex which is also the first register (R0) of register bank 1. Thus, if one is going to use more than one register bank, the stack pointer should be initialized to an area of RAM not used for data storage.

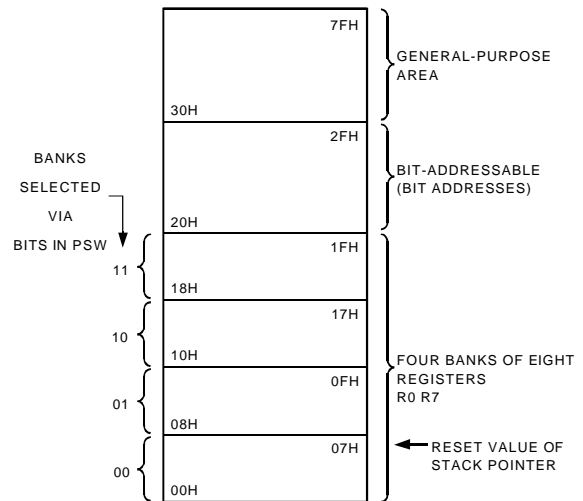

Figure 2. Lower 128 Bytes of Internal Data Memory

(4) Internal XRAM

The ADuC844 contains 2kBytes of on-chip extended data memory. This memory although on-chip is accessed via the MOVX instruction. The 2kBytes of internal XRAM are mapped into the bottom 2kBytes of the external address space if the CFG844.0 bit is set, otherwise access to the external data memory will occur just like a standard 8051.

Even with the CFG844.0 bit set access to the external XRAM will occur once the 24 bit DPTR is greater than 0007FFH.

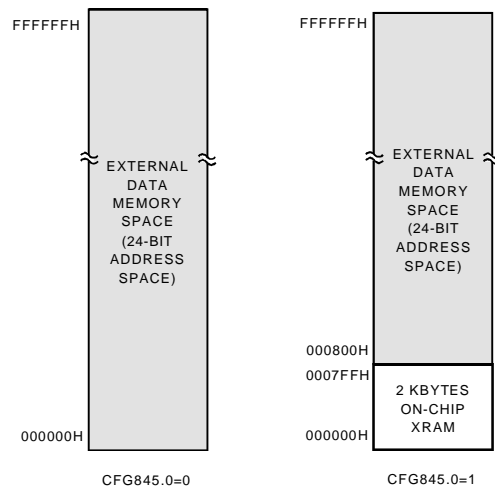

Figure 3: Internal and External XRAM

When accessing the internal XRAM the P0, P2 port pins as well as the RD and WR strobes will not be output as per a standard 8051 MOVX instruction. This allows the user to use these port pins as standard I/O.

The upper 1792 bytes of the internal XRAM can be configured to be used as an extended 11-bit stack pointer.

By default the stack will operate exactly like an 8052 in that it will rollover from FFh to 00h in the general purpose RAM. On the ADuC844 however it is possible (by setting CFG844.7) to enable the 11-bit extended stack pointer. In this case the stack will rollover from FFh in RAM to 0100h in XRAM.

ADuC844

The 11-bit stack pointer is visible in the SP and SPH SFRs. The SP SFR is located at 81h as with a standard 8052. The SPH SFR is located at B7h. The 3 LSBs of this SFR contain the 3 extra bits necessary to extend the 8-bit stack pointer into an 11-bit stack pointer.

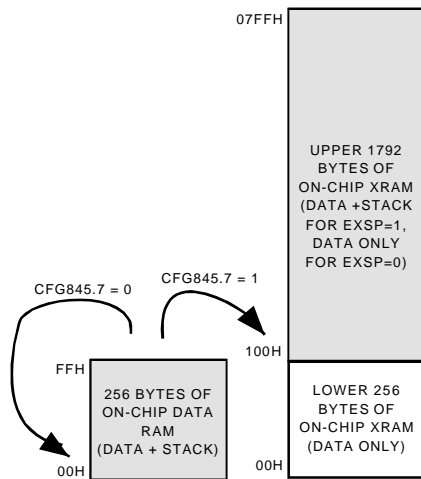

Figure 4. Extended Stack Pointer Operation

External Data Memory (External XRAM)

Just like a standard 8051 compatible core the ADuC844 can access external data memory using a MOVX instruction. The MOVX instruction automatically outputs the various control strobes required to access the data memory.

The ADuC844 however, can access up to 16MBytes of external data memory. This is an enhancement of the 64kBytes external data memory space available on a standard 8051 compatible core. The external data memory is discussed in more detail in the ADuC844 Hardware Design Considerations section.

SPECIAL FUNCTION REGISTERS (SFRs)

The SFR space is mapped into the upper 128 bytes of internal data memory space and accessed by direct addressing only. It provides an interface between the CPU and all on chip peripherals. A block diagram showing the programming model of the ADuC844 via the SFR area is shown in Figure 5.

All registers except the Program Counter (PC) and the four general-purpose register banks, reside in the SFR area. The SFR registers include control, configuration, and data registers that provide an interface between the CPU and all on-chip peripherals.

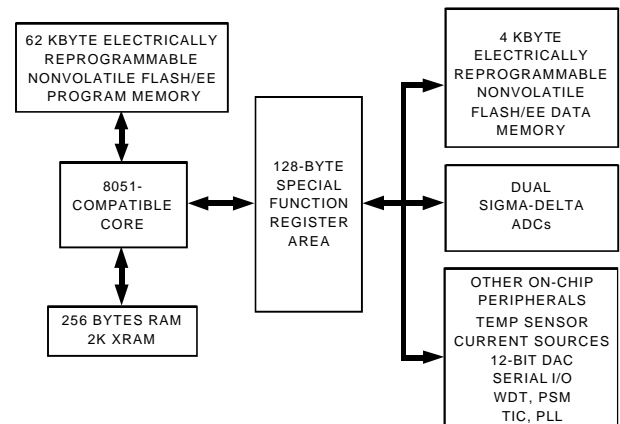

Figure 5. Programming Model

Accumulator SFR (ACC)

ACC is the Accumulator register and is used for math operations including addition, subtraction, integer multiplication and division, and Boolean bit manipulations. The mnemonics for accumulator-specific instructions refer to the Accumulator as A.

B SFR (B)

The B register is used with the ACC for multiplication and division operations. For other instructions it can be treated as a general-purpose scratchpad register.

Data Pointer (DPTR)

The Data Pointer is made up of three 8-bit registers, named DPP (page byte), DPH (high byte) and DPL (low byte). These are used to provide memory addresses for internal and external code access and external data access. It may be manipulated as a 16-bit register (DPTR = DPH, DPL), although INC DPTR instructions will automatically carry over to DPP, or as three independent 8-bit registers (DPP, DPH, DPL).

The ADuC844 supports dual data pointers. Refer to the Dual Data Pointer section later in this datasheet.

Stack Pointer (SP and SPH)

The SP SFR is the stack pointer and is used to hold an internal RAM address that is called the 'top of the stack.' The SP register is incremented before data is stored during PUSH and CALL executions. While the Stack may reside anywhere in on-chip RAM, the SP register is initialized to 07H after a reset. This causes the stack to begin at location 08H.

As mentioned earlier the ADuC844 offers an extended 11-bit stack pointer. The 3 extra bits to make up the 11-bit stack pointer are the 3 LSBs of the SPH byte located at B7h. To enable the SPH SFR the

EXSP (CFG844.7) bit must be set otherwise the SPH SFR cannot be read or written to.

Program Status Word (PSW)

The PSW SFR contains several bits reflecting the current status of the CPU as detailed in Table I.

SFR Address	D0H
Power ON Default Value	00H
Bit Addressable	Yes

Table I. PSW SFR Bit Designations

Bit	Name	Description
7	CY	Carry Flag
6	AC	Auxiliary Carry Flag
5	F0	General-Purpose Flag
4	RS1	Register Bank Select Bits
3	RS0	RS1 RS0 Selected Bank
		0 0 0
		0 1 1
		1 0 2
		1 1 3
2	OV	Overflow Flag
1	F1	General-Purpose Flag
0	P	Parity Bit

The PCON SFR contains bits for power-saving options and general-purpose status flags as shown in Table II.

SFR Address	87H
Power ON Default Value	00H
Bit Addressable	No

Table II. PCON SFR Bit Designations

Bit	Name	Description
7	SMOD	Double UART Baud Rate
6	SERIPD	SPI Power-Down Interrupt Enable
5	INT0PD	INT0 Power-Down Interrupt Enable
4	ALEOFF	Disable ALE Output
3	GF1	General-Purpose Flag Bit
2	GF0	General-Purpose Flag Bit
1	PD	Power-Down Mode Enable
0	IDL	Idle Mode Enable

The CFG844 SFR contains the necessary bits to configure the internal XRAM and the extended SP. By default it configures the user into 8051 mode. i.e. extended SP is disabled, internal XRAM is disabled.

SFR Address	AFhH
Power ON Default Value	00H
Bit Addressable	No

Table III. CFG844 SFR Bit Designations

Bit	Name	Description
7	EXSP	Extended SP Enable If this bit is set then the stack will rollover from SPH/SP = 00FFh to 0100h. If this bit is clear then the SPH SFR will be disabled and the stack will rollover from SP=FFh to SP =00h
6	----	----
5	----	----
4	----	----
3	----	----
2	----	----
1	----	----
0	XRAMEN	XRAM Enable Bit If this bit is set then the internal XRAM will be mapped into the lower 2kBytes of the external address space. If this bit is clear then the internal XRAM will not be accessible and the external data memory will be mapped into the lower 2kBytes of external data memory. (see figure 3)

PRELIMINARY TECHNICAL DATA

ADuC844

COMPLETE SFR MAP

Figure 5 below shows a full SFR memory map and the SFR contents after RESET. NOT USED indicates unoccupied SFR locations. Unoccupied locations in the SFR address space are not implemented; i.e., no register exists at this location. If an unoccupied location is read, an unspecified value is returned. SFR locations that are reserved for future use are shaded (RESERVED) and should not be accessed by user software.

ISPI FFH 0	WCOL FEH 0	SPE FDH 0	SPIM FCH 0	CPOL FBH 0	CPHA FAH 1	SPR1 F9H 0	SPR0 F8H 0	BITS	SPICON FBH 04H	RESERVED	RESERVED	DACL FBH 00H	DACH FCH 00H	DACCON FDH 00H	RESERVED	RESERVED
F7H 0	F6H 0	F5H 0	F4H 0	F3H 0	F2H 0	F1H 0	F0H 0	BITS	B F0H 00H	RESERVED	RESERVED	NOT USED	RESERVED	RESERVED	RESERVED	SPIDAT F7H 00H
MDO EFH 0	MDE EEH 0	MC0 EDH 0	MDI ECH 0	I2CM EBH 0	I2CRS EAH 0	I2CTX E9H 0	I2CI E8H 0	BITS	I2CCON E8H 00H	GN0L* E9H 55H	GN0M* EAH 55H	GN0H* EBH 53H	GN1L* ECH 9AH	GN1H* EDH 59H	RESERVED	RESERVED
E7H 0	E6H 0	E5H 0	E4H 0	E3H 0	E2H 0	E1H 0	E0H 0	BITS	ACC E0H 00H	OF0L E1H 00H	OF0M E2H 00H	OF0H E3H 80H	OF1L E4H 00H	OF1H E5H 80H	RESERVED	RESERVED
RDY0 DFH 0	RDY1 DEH 0	CAL DDH 0	NOXREF DCH 0	ERR0 DBH 0	ERR1 DAH 0	D9H 0	D8H 0	BITS	ADCSTAT DBH 00H	ADC0L D9H 00H	ADC0M DAH 00H	ADC0H DBH 00H	ADC1M DCH 00H	ADC1H DDH 00H	ADC1L DEH 00H	PSMCON DFH DEH
CY D7H 0	AC D6H 0	F0 D5H 0	RSI D4H 0	RS0 D3H 0	OV D2H 0	FI D1H 0	P D0H 0	BITS	PSW D0H 00H	ADCMODE D1H 00H	ADC0CON D2H 07H	ADC1CON D3H 00H	SF D4H 45H	ICON D5H 00H	RESERVED	PLLCON D7H 03H
TF2 CFH 0	EXF2 CEH 0	RCLK CDH 0	TCLK CCH 0	EXEN2 CBH 0	TR2 CAH 0	CNT2 C9H 0	CAP2 C8H 0	BITS	T2CON C8H 00H	RESERVED	RCAP2L CAH 00H	RCAP2H CBH 00H	TL2 CCH 00H	TH2 CDH 00H	RESERVED	RESERVED
PRE3 C7H 0	PRE2 C6H 0	PRE1 C5H 0	PRE0 C4H 0	WDIR C3H 0	WDS C2H 0	WDE C1H 0	WDWR C0H 0	BITS	WDCON C0H 10H	RESERVED	CHIPID C2H 22H	RESERVED	RESERVED	RESERVED	EADRL C6H 00H	EADRH C7H 00H
BFH 0	PADC BEH 0	PT2 BDH 0	PS BCH 0	PT1 BBH 0	PX1 BAH 0	PT0 B9H 0	PX0 B8H 0	BITS	IP B8H 00H	ECON B9H 00H	RESERVED	RESERVED	EDATA1 BCH 00H	EDATA2 BDH 00H	EDATA3 BEH 00H	EDATA4 BFH 00H
RD B7H 1	WR B6H 1	T1 B5H 1	T0 B4H 1	INTT B3H 1	INT0 B2H 1	TXD B1H 1	RXD B0H 1	BITS	P3 B0H FFH	PWM0L B1H 00H	PWM0H B2H 00H	PWM1L B3H 00H	PWM1H B4H 00H	RESERVED	RESERVED	SPH B7H 00H
EA AFH 0	EADC AEH 0	ET2 ADH 0	ES ACH 0	ET1 ABH 0	EX1 AAH 0	ET0 A9H 0	EX0 A8H 0	BITS	IE A8H 00H	IEIP2 A9H A0H	RESERVED	RESERVED	RESERVED	RESERVED	PWMCON AEH 00H	CFG844 AFH 00H
A7H 1	A6H 1	A5H 1	A4H 1	A3H 1	A2H 1	A1H 1	A0H 1	BITS	P2 A0H FFH	TIMECON A1H 00H	HTHSEC ⁽¹⁾ A2H 00H	SEC ⁽¹⁾ A3H 00H	MIN ⁽¹⁾ A4H 00H	HOUR ⁽¹⁾ A5H 00H	INTVAL A6H 00H	DPCON A7H 00H
SM0 9FH 0	SM1 9EH 0	SM2 9DH 0	REN 9CH 0	TB8 9BH 0	RB8 9AH 0	T1 99H 0	R1 98H 0	BITS	SCON 98H 00H	SBUF 99H 00H	I2CDAT 9AH 00H	I2CADD 9BH 55H	NOT USED	T3FD ⁽¹⁾ 9DH 00H	T3CON 9EH 00H	RESERVED
97H 1	96H 1	95H 1	94H 1	93H 1	92H 1	T2EX 91H 1	T2 90H 1	BITS	P1 90H FFH	RESERVED	RESERVED	RESERVED	RESERVED	RESERVED	RESERVED	RESERVED
TF1 8FH 0	TR1 8EH 0	TF0 8DH 0	TR0 8CH 0	IE1 8BH 0	IT1 8AH 0	IE0 89H 0	IT0 88H 0	BITS	TCON 88H 00H	TMOD 89H 00H	TL0 8AH 00H	TL1 8BH 00H	TH0 8CH 00H	TH1 8DH 00H	RESERVED	RESERVED
87H 1	86H 1	85H 1	84H 1	83H 1	82H 1	81H 1	80H 1	BITS	P0 80H FFH	SP 81H 07H	DPL 82H 00H	DPH 83H 00H	DPP 84H 00H	RESERVED	RESERVED	PCON 87H 00H

* CALIBRATION COEFFICIENTS ARE PRECONFIGURED AT POWER-UP TO FACTORY CALIBRATED VALUES.

⁽¹⁾ THESE SFRs MAINTAIN THEIR PRE-RESET VALUES AFTER A RESET IF TIMECON.0=1.

SFR MAP KEY:

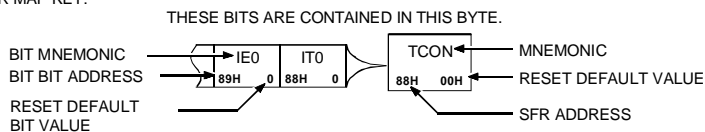

SFR NOTE:

SFRs WHOSE ADDRESSES END IN 0H OR 8H ARE BIT-ADDRESSABLE.

Figure 6: Complete SFR Map

INTRODUCTION

The ADuC844 is a pin compatible upgrade to the ADuC834 provide increased core performance. The ADuC844 has a single cycle 8052 core allow operation at up to 12.58MIPs. It has all the same features as the ADuC834 but the standard 12-cycle 8052 core has been replaced with a 12.6MIPs single cycle core.

Since the ADuC844 and ADuC834 share the same feature set only the differences between the two chips are documented here. For full documentation on the ADuC834 please consult the datasheet available at <http://www.analog.com/microconverter>

8052 Instruction Set

The following pages document the number of clock cycles required for each instruction. Most instructions are executed in one or two clock cycles resulting in 12.6MIPs peak performance when operating at PLLCON = 00H.

Timer Operation

Timers on a standard 8052 increment by one with each machine cycle. On the ADuC842 one machine cycle is equal to one clock cycle hence the timers will increment at the same rate as the core clock.

ALE

The output on the ALE pin on the ADuC834 was a clock at 1/6th of the core operating frequency. On the ADuC844 the ALE pin operates as follows.

For a single machine cycle instruction: ALE is high for the first half of the machine cycle and low for the second half. The ALE output is at the core operating frequency. For a two or more machine cycle instruction: ALE is high for the first half of the first machine cycle and then low for the rest of the machine cycles.

External Memory Access

There is no support for external program memory access on the ADuC844. When accessing external RAM the EWAIT register may need to be programmed in order to give extra machine cycles to MOVX commands. This is to account for differing external RAM access speeds.

INSTRUCTION TABLE**TABLE IV: Optimized Single Cycle 8051 Instruction Set**

Mnemonic Arithmetic	Description	Bytes	Cycles
ARITHMETIC			
ADD A,Rn	Add register to A	1	1
ADD A,@Ri	Add indirect memory to A	1	2
ADDC A,Rn	Add register to A with carry	1	1
ADDC A,@Ri	Add indirect memory to A with carry	1	2
ADD A,dir	Add direct byte to A	2	2
ADD A,#data	Add direct byte to A with carry	2	2
SUBB A,Rn	Subtract register from A with borrow	1	1
SUBB A,@Ri	Subtract indirect memory from A with borrow	1	2
SUBB A,dir	Subtract direct from A with borrow	2	2
SUBB A,#data	Subtract immediate from A with borrow	1	1
INC A	Increment A	1	1
INC Rn	Increment register	1	1
INC @Ri	Increment indirect memory	1	2
INC dir	Increment direct byte	2	2
INC DPTR	Increment data pointer	1	3
DEC A	Decrement A	1	1
DEC Rn	Decrement Register	1	1
DEC @Ri	Decrement indirect memory	1	2
DEC dir	Decrement direct byte	2	2
MUL AB	Multiply A by B	1	9
DIV AB	Divide A by B	1	9
DA A	Decimal Adjust A	1	2

PRELIMINARY TECHNICAL DATA

ADuC844

Mnemonic Arithmetic	Description	Bytes	Cycles
LOGIC			
ANL A,Rn	AND register to A	1	1
ANL A,@Ri	AND indirect memory to A	1	2
ANL A,dir	AND direct byte to A	2	2
ANL A,#data	AND immediate to A	2	2
ANL dir,A	AND A to direct byte	2	2
ANL dir,#data	AND immediate data to direct byte	3	3
ORL A,Rn	OR register to A	1	1
ORL A,@Ri	OR indirect memory to A	1	2
ORL A,dir	OR direct byte to A	2	2
ORL A,#data	OR immediate to A	2	2
ORL dir,A	OR A to direct byte	2	2
ORL dir,#data	OR immediate data to direct byte	3	3
XRL A,Rn	Exclusive-OR register to A	1	1
XRL A,@Ri	Exclusive-OR indirect memory to A	2	2
XRL A,#data	Exclusive-OR immediate to A	2	2
XRL dir,A	Exclusive-OR A to direct byte	2	2
XRL A,dir	Exclusive-OR indirect memory to A	2	2
XRL dir,#data	Exclusive-OR immediate data to direct	3	3
CLR A	Clear A	1	1
CPL A	Complement A	1	1
SWAP A	Swap Nibbles of A	1	1
RL A	Rotate A left	1	1
RLC A	Rotate A left through carry	1	1
RR A	Rotate A right	1	1
RRC A	Rotate A right through carry	1	1
BOOLEAN			
CLR C	Clear carry	1	1
CLR bit	Clear direct bit	2	2
SETB C	Set Carry	1	1
SETB bit	Set direct bit	2	2
CPL C	Complement carry	1	1
CPL bit	Complement direct bit	2	2
ANL C,bit	AND direct bit and carry	2	2
ANL C,/bit	AND direct bit inverse to carry	2	2
ORL C,bit	OR direct bit and carry	2	2
ORL C,/bit	OR direct bit inverse to carry	2	2
MOV C,bit	Move direct bit to carry	2	2
MOV bit,C	Move carry to direct bit	2	2

Mnemonic Arithmetic	Description	Bytes	Cycles
BRANCHING			
JMP @A+DPTR	Jump indirect relative to DPTR	1	3
RET	Return from subroutine	1	4
RETI	Return from interrupt	1	4
ACALL addr11	Absolute jump to subroutine	2	3
AJMP addr11	Absolute jump unconditional	2	3
SJMP rel	Short jump (relative address)	2	3
JC rel	Jump on carry = 1	2	3
JNC rel	Jump on carry = 0	2	3
JZ rel	Jump on accumulator = 0	2	3
JNZ rel	Jump on accumulator != 0	2	3
DJNZ Rn,rel	Decrement register, jnz relative	2	3
LJMP	Long jump unconditional	3	4
LCALL addr16	Long jump to subroutine	3	4
JB bit,rel	Jump on direct bit = 1	3	4
JNB bit,rel	Jump on direct bit = 0	3	4
JBC bit,rel	Jump on direct bit = 1 and clear	3	4
CJNE A,dir,rel	Compare A, direct JNE relative	3	4
CJNE A,#data,rel	Compare A, immediate JNE relative	3	4
CJNE Rn,#data,rel	Compare register, immediate JNE relative	3	4
CJNE @Ri,#data,rel	Compare indirect, immediate JNE relative	3	4
DJNZ dir,rel	Decrement direct byte, JNZ relative	3	4
MISCELLANEOUS			
NOP	No operation	1	1

Notes:

1. One cycle is one clock.
2. Cycles of MOVX instructions are 4 cycles when they have 0 wait state. Cycles of MOVX instructions are 4+N cycles when they have N wait states.
3. Cycles of LCALL instruction are 3 cycles when the LCALL instruction comes from interrupt.

PRELIMINARY TECHNICAL DATA

ADuC844

OUTLINE DIMENSIONS

52-Lead Plastic Quad Flatpack [MQFP] (S-52)

Dimensions shown in millimeters

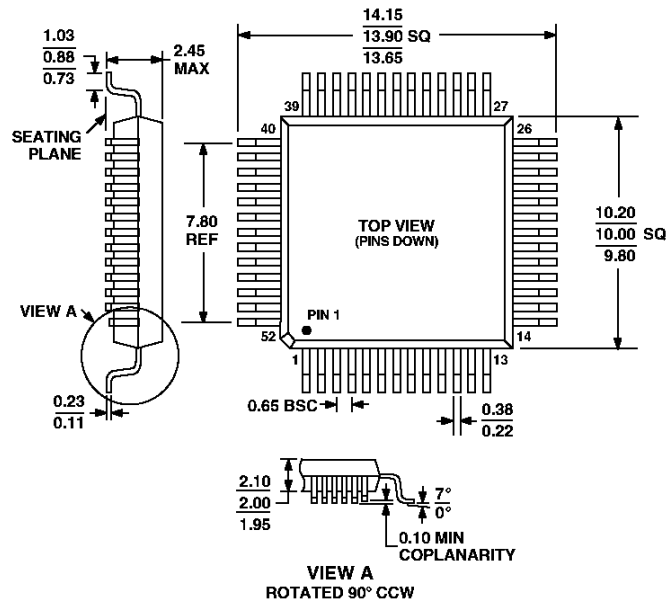

56-Lead Frame Chip Scale Package [LFCSP] 8x8 mm Body (CP-56)

Dimensions shown in millimeters

