

# TC Series

This product has been **DISCONTINUED**

## PECOS® Resistors Thick Film on Porcelainized Steel Substrate

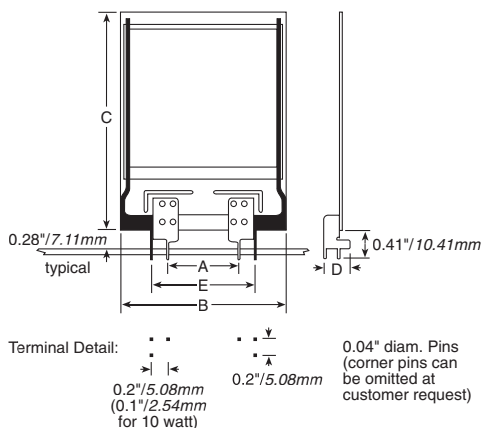

PECOS® stands for Porcelain Enamel Coating on Steel. It is a plate resistor system utilizing thick film ruthenium oxide on a porcelain coated steel substrate. Copper plated silver conductors are employed and the resistive element is protected by a glass passivation layer.

These resistors offer low inductance (50nh @ 1MHz) and very high power densities (15W/in<sup>2</sup>). Being PC-board mountable, they are economic to install and best suited for applications under 200V operating.

### FEATURES

- 15W/in<sup>2</sup> Power Density
- Low Inductance
- Easy to Install

### SPECIFICATIONS

#### Material

**Substrate:** PECOS® (Porcelain Enamel Coating on Steel)

**Resistor:** Ruthenium Oxide

**Coating:** Glass

**Terminals:** Solder Plated Phosphor Bronze, riveted in place and electrically connected with high temperature solder.

**Thermal Conductivity:** 60 Watts/Meter/°C, x-y direction

**Temperature Coefficient:** 150 ppm/°C ≥ 1Ω

#### Electrical

**Ohmic Range:** 1-2500Ω

**Tolerance:** ±1-5% to 20%

**Power Rating:** Based on 25°C free air

**Maximum Operating Voltage:** 200 VDC

**Overload:** Five times rated power, as long as the one second average dissipation does not exceed the wattage rating.

ΔR: ±2%, 2000 hours

### DERATING CURVE

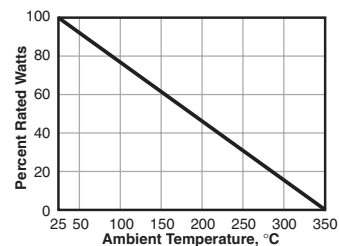

Series	Watts	Dimensions (in. / mm)				
		A	B	C	D	E
TC010PA	10	0.300 / 7.62	0.55 / 13.97	1.25 / 31.75	0.29 / 7.37	0.50 / 12.70
TC020PA	20	0.600 / 15.24	1.10 / 27.94	1.40 / 35.56	0.37 / 9.40	1.00 / 25.40
TC025PA	25	1.000 / 25.40	1.60 / 40.64	1.25 / 31.75	0.37 / 9.40	1.40 / 35.56
TC050PA	50	1.000 / 25.40	1.75 / 44.45	2.50 / 63.50	0.37 / 9.40	1.40 / 35.56
TC100PA	100	1.300 / 33.02	2.55 / 64.77	3.35 / 85.09	0.37 / 9.40	1.70 / 43.18

### ORDERING INFORMATION

E = RoHS compliant  
Available Jan. 2006

**TC025PA5R00FE**

Series: TC  
Power Rating: 025  
Package: PA = standard  
Resistance (Ω): 5R00 = 5.0, 50R0 = 50.0  
Tolerance: J = 5%, K = 10%, L\* = 20%

\*20% Values are not laser trimmed and offer enhanced surge handling.