

June 2007

HYB39SC256[80/16]0FE
HYI39SC256[80/16]0FF

256-MBit Synchronous DRAM
Green Product
SDRAM

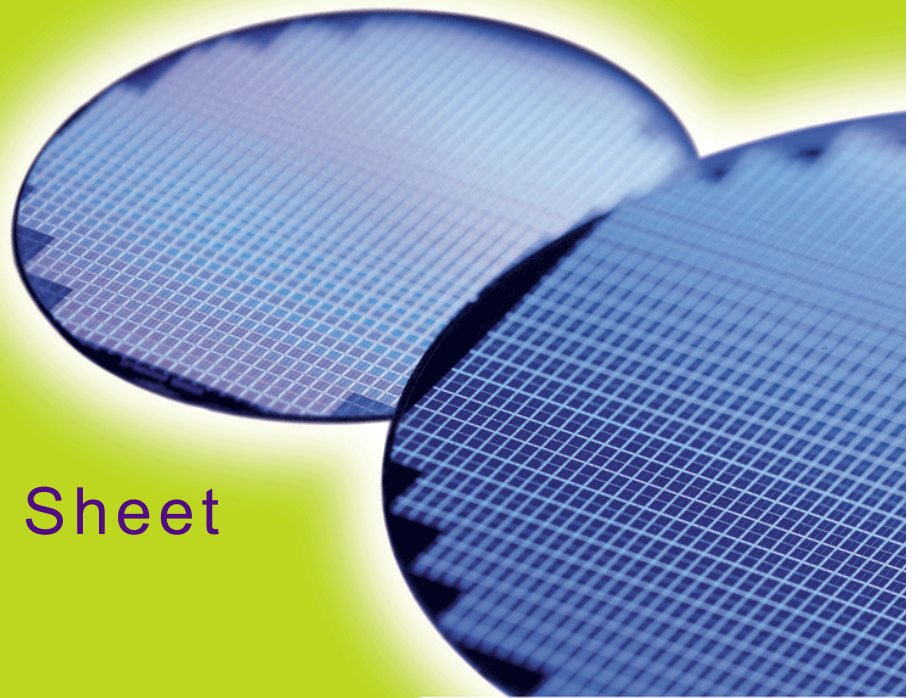

Internet Data Sheet

Rev. 1.25

www.qimonda.com

Qimonda



HYB39SC256[80/16]0FE, HYI39SC256[80/16]0FF	
Revision History: 2007-06, Rev. 1.25	
Page	Subjects (major changes since last revision)
All	Adapted internet edition
41	Corrected in figure 28 (auto refresh) tRC to tRFC
Previous Revision: 2007-06, Rev. 1.24	
8	Corrected figure 1
11,12	Corrected block diagram
Previous Revision: 2007-06, Rev. 1.23	
18	Added text for Auto Refresh Command (CBR)
Previous Revision: 2007-06, Rev. 1.22	
6	Corrected ball DQ0 to 2,8A for data signals x16 organization
6	Corrected data Data Signal Bus [7:0] for data signals x8 organization
Previous Revision: 2007-06, Rev. 1.21	
13	Corrected operation command "Power Down / Clock suspend ..." in truth table
Previous Revision: 2007-05, Rev. 1.2	
13	Corrected operation command "Power Down Exit" to X (WE#)
15	Corrected text to "After the mode register is set a NOP command is required" , chapter 3.2
19	Corrected text to "One clock delay is required for mode entry and exit", chapter 3.4
21	Corrected the line "Input Capacitances: CK" in table 10, chapter 4
21	Corrected to A0-A12 in table 10, chapter 4
22	Corrected tCK MIN in table 13
22	Corrected CLE setup time in table 13
Previous Revision: 2007-05, Rev. 1.11	
6	Corrected A6 position from H to 3H in table 3
Previous Revision: 2006-09, Rev. 1.1	

We Listen to Your Comments

Any information within this document that you feel is wrong, unclear or missing at all?

Your feedback will help us to continuously improve the quality of this document.

Please send your proposal (including a reference to this document) to:

techdoc@qimonda.com



1 Overview

This chapter lists all main features of the product family HY[B/I]39SC256[80/16]0F[E/F] and the ordering information.

1.1 Features

- Fully Synchronous to Positive Clock Edge
- 0 to 70 °C Operating Temperature for HYB...
- -40 to 85 °C Operating Temperature for HYL...
- Four Banks controlled by BA0 & BA1
- Programmable CAS Latency: 2 & 3
- Programmable Wrap Sequence: Sequential or Interleave
- Programmable Burst Length: 1, 2, 4, 8 and full page
- Multiple Burst Read with Single Write Operation
- Automatic and Controlled Precharge Command
- Data Mask for Read / Write control (x8, x16)
- Data Mask for Byte Control (x16)
- Auto Refresh (CBR) and Self Refresh
- Power Down and Clock Suspend Mode
- 8192 refresh cycles / 64 ms (7.8 μ s)
- Random Column Address every CLK (1-N Rule)
- Single 3.3 V \pm 0.3 V Power Supply
- LVTTTL Interface
- Plastic Packages
 - PG-TSOPII-54 (400mil width)
 - PG-TFBGA-54 (12 mm x 8 mm)
- RoHS compliant product

TABLE 1
Performance

Product Type Speed Code			-6	-7	Unit
Speed Grade			PC166-333	PC143-333 PC133-222 ¹⁾	—
Max. Clock Frequency	@CL3	f_{CK3}	166	143	MHz
		t_{CK3}	6	7	ns
		t_{AC3}	5.4	5.4	ns
	@CL2	t_{CK2}	7.5	7.5	ns
		t_{AC2}	5.4	5.4	ns

1) Max. Frequency CL/ t_{RCD} / t_{RP}

HY[B/I]39SC256[80/16]0F[E/F]
256-MBit Synchronous DRAM

1.2 Description

The HY[B/I]39SC256[80/16]0F[E/F] are four bank Synchronous DRAM's organized as 16 MBit $\times 8$ and 8 Mbit $\times 16$ respectively. These synchronous devices achieve high speed data transfer rates for CAS latencies by employing a chip architecture that prefetches multiple bits and then synchronizes the output data to a system clock. The chip is fabricated with Qimonda advanced 0.11 μm 256-MBit DRAM process technology.

The device is designed to comply with all industry standards set for synchronous DRAM products, both electrically and mechanically. All of the control, address, data input and

output circuits are synchronized with the positive edge of an externally supplied clock.

Operating the four memory banks in an interleave fashion allows random access operation to occur at a higher rate than is possible with standard DRAMs. A sequential and gapless data rate is possible depending on burst length, CAS latency and speed grade of the device.

Auto Refresh (CBR) and Self Refresh operation are supported. These devices operate with a single $3.3\text{ V} \pm 0.3\text{ V}$ power supply. All 256-Mbit components are available in PG-TSOPII-54 and PG-TFBGA-54 packages.

TABLE 2**Ordering Information for RoHS Compliant Products**

Product Type ¹⁾	Speed Grade	Description	Package	Note
Standard Operating Temperature (0 to 70 °C)				
HYB39SC256800FE-6	PC166-333	166MHz 16M $\times 8$ SDRAM	PG-TSOPII-54	2)
HYB39SC256160FE-6		166MHz 8M $\times 16$ SDRAM		
HYB39SC256800FE-7	PC133-222	143MHz 16M $\times 8$ SDRAM		
HYB39SC256800FEH-7		143MHz 8M $\times 16$ SDRAM		
HYB39SC256160FE-7				
HYB39SC256160FEH-7				
HYB39SC256160FF-6	PC166-333	166MHz 8M $\times 16$ SDRAM	PG-TFBGA-54	2)
HYB39SC256160FF-7	PC133-222	143MHz 8M $\times 16$ SDRAM		
HYB39SC256800FF-7		143MHz 8M $\times 8$ SDRAM		
Industrial Operating Temperature (-40 to 85 °C)				
HYI39SC256800FE-6	PC166-333	166MHz 16M $\times 8$ SDRAM	PG-TSOPII-54	2)
HYI39SC256160FE-6		166MHz 8M $\times 16$ SDRAM		
HYI39SC256800FE-7	PC133-222	143MHz 16M $\times 8$ SDRAM		
HYI39SC256160FE-7		143MHz 8M $\times 16$ SDRAM		

1) Please check with your Qimonda representative that leadtime and availability of your preferred device and version meet your project requirements.

2) RoHS Compliant Product: Restriction of the use of certain hazardous substances (RoHS) in electrical and electronic equipment as defined in the directive 2002/95/EC issued by the European Parliament and of the Council of 27 January 2003. These substances include mercury, lead, cadmium, hexavalent chromium, polybrominated biphenyls and polybrominated biphenyl ethers.

Note: For product nomenclature see **Chapter 6** of this data sheet



2 Configuration

This chapter contains the pin configuration table, the TSOP and FBGA package drawing, and the block diagrams for the ×8, ×16 organization of the SDRAM.

2.1 Pin Configuration

Listed below are the pin configurations sections for the various signals of the SDRAM

TABLE 3
Pin Configuration of the SDRAM

Pin No.	Name	Pin Type	Buffer Type	Function
Clock Signals x8/x16 Organization				
38,2F	CLK	I	LVTTTL	Clock Signal CK
37,3F	CKE	I	LVTTTL	Clock Enable
Control Signals x8/x16 Organization				
18, 8F	$\overline{\text{RAS}}$	I	LVTTTL	Row Address Strobe (RAS), Column Address Strobe (CAS), Write Enable (WE)
17, 7F	$\overline{\text{CAS}}$	I	LVTTTL	
16, 9F	$\overline{\text{WE}}$	I	LVTTTL	
19, 9G	$\overline{\text{CS}}$	I	LVTTTL	Chip Select
Address Signals x8/x16 Organization				
20, 7G	BA0	I	LVTTTL	Bank Address Signals 1:0
21, 8G	BA1	I	LVTTTL	
23, 7H	A0	I	LVTTTL	Address Signal, Address Signal 10/Auto precharge
24, 8H	A1	I	LVTTTL	
25, 8J	A2	I	LVTTTL	
26, 7J	A3	I	LVTTTL	
29, 3J	A4	I	LVTTTL	
30, 2J	A5	I	LVTTTL	
31, 3H	A6	I	LVTTTL	
32, 2H	A7	I	LVTTTL	
33, 1H	A8	I	LVTTTL	
34, 3G	A9	I	LVTTTL	
22, 9H	A10	I	LVTTTL	
35, 2G	A11	I	LVTTTL	
36, 1G	A12	I	LVTTTL	



Pin No.	Name	Pin Type	Buffer Type	Function
Data Signals x8 Organization				
2, 8A	DQ0	I/O	LVTTTL	Data Signal Bus [7:0]
5, 8B	DQ1	I/O	LVTTTL	
8, 8C	DQ2	I/O	LVTTTL	
11, 8D	DQ3	I/O	LVTTTL	
44, 2D	DQ4	I/O	LVTTTL	
47, 2C	DQ5	I/O	LVTTTL	
50, 2B	DQ6	I/O	LVTTTL	
53, 2A	DQ7	I/O	LVTTTL	
Data Signals x16 Organization				
2, 8A	DQ0	I/O	LVTTTL	Data Signal Bus [15:0]
4, 9B	DQ1	I/O	LVTTTL	
5, 8B	DQ2	I/O	LVTTTL	
7, 9C	DQ3	I/O	LVTTTL	
8, 8C	DQ4	I/O	LVTTTL	
10, 9D	DQ5	I/O	LVTTTL	
11, 8D	DQ6	I/O	LVTTTL	
13, 9E	DQ7	I/O	LVTTTL	
42, 1E	DQ8	I/O	LVTTTL	
44, 2D	DQ9	I/O	LVTTTL	
45, 1D	DQ10	I/O	LVTTTL	
47, 2C	DQ11	I/O	LVTTTL	
48, 1C	DQ12	I/O	LVTTTL	
50, 2B	DQ13	I/O	LVTTTL	
51, 1B	DQ14	I/O	LVTTTL	
53, 2A	DQ15	I/O	LVTTTL	
Data Mask x8 Organization				
39, 1F	DQM	I/O	LVTTTL	Data Mask
Data Mask x16 Organization				
39, 1F	UDQM	I/O	LVTTTL	Data Mask Upper Byte
15, 8E	LDQM	I/O	LVTTTL	Data Mask Lower Byte
Power Supplies x8/x16 Organization				
3B, 3D, 7A, 7C	VDDQ	PWR	—	Power Supply
7E, 9A, 9J	VDD	PWR	—	Power Supply
3A, 3C, 7B, 7D	VSSQ	PWR	—	Power Supply Ground for DQs
1J, 1A, 3E	VSS	PWR	—	Power Supply Ground



HY[B/I]39SC256[80/16]0F[E/F]
256-MBit Synchronous DRAM

Pin No.	Name	Pin Type	Buffer Type	Function
Not connected x8 Organization				
7, 10, 13, 15, 40, 42, 45, 48, 51, 1B, 1C, 1D, 1E, 2E, 8E, 9B, 9C, 9D, 9E	NC	NC	—	Not connected
Not connected x16 Organization				
40, 2E	NC	NC	—	Not connected

FIGURE 1
Pin Configuration PG-TSOPII-54

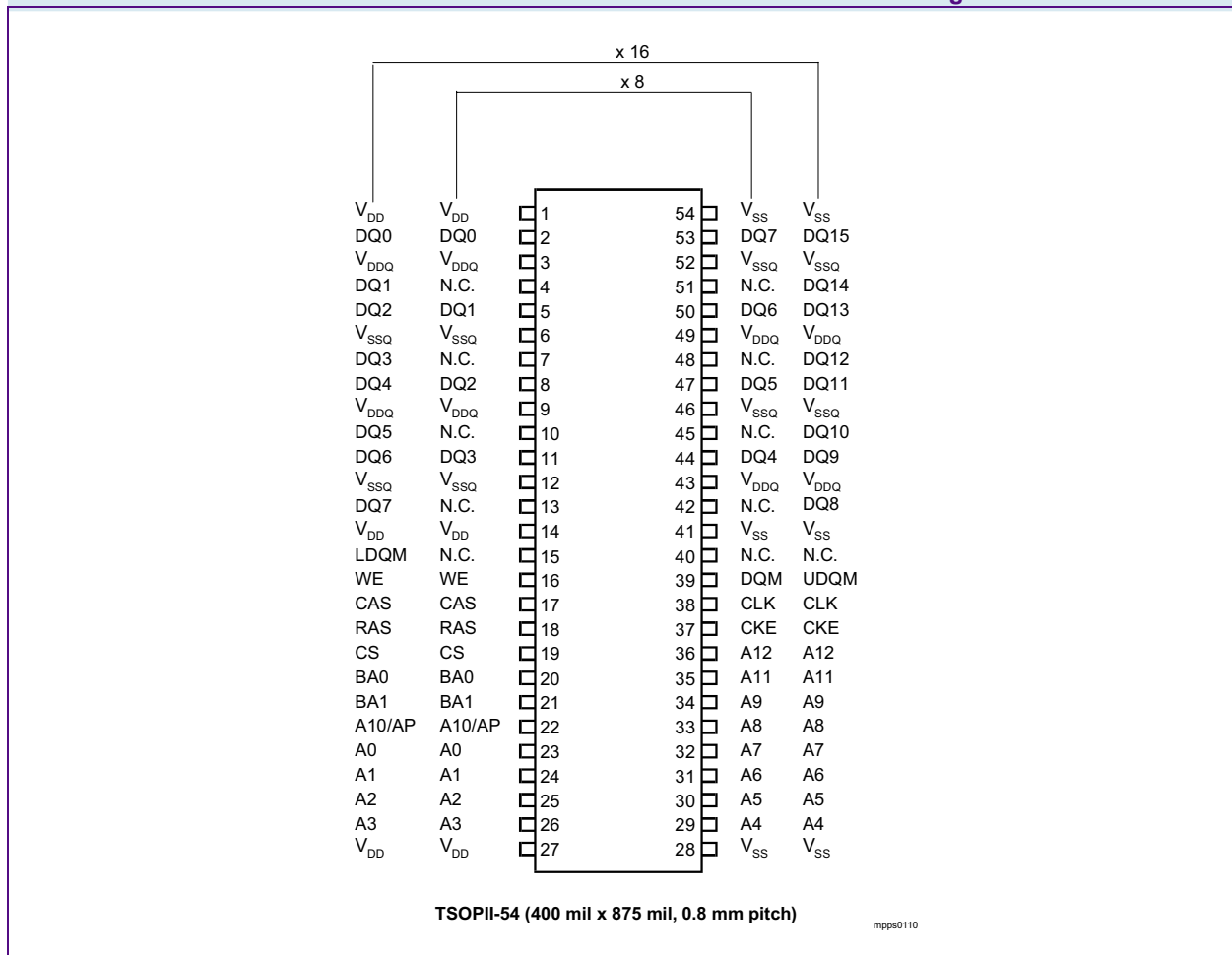



HY[B/I]39SC256[80/16]0F[E/F]
256-MBit Synchronous DRAM

FIGURE 2

Ballout for ×16 Components, PG-TFBGA-54 (top view)

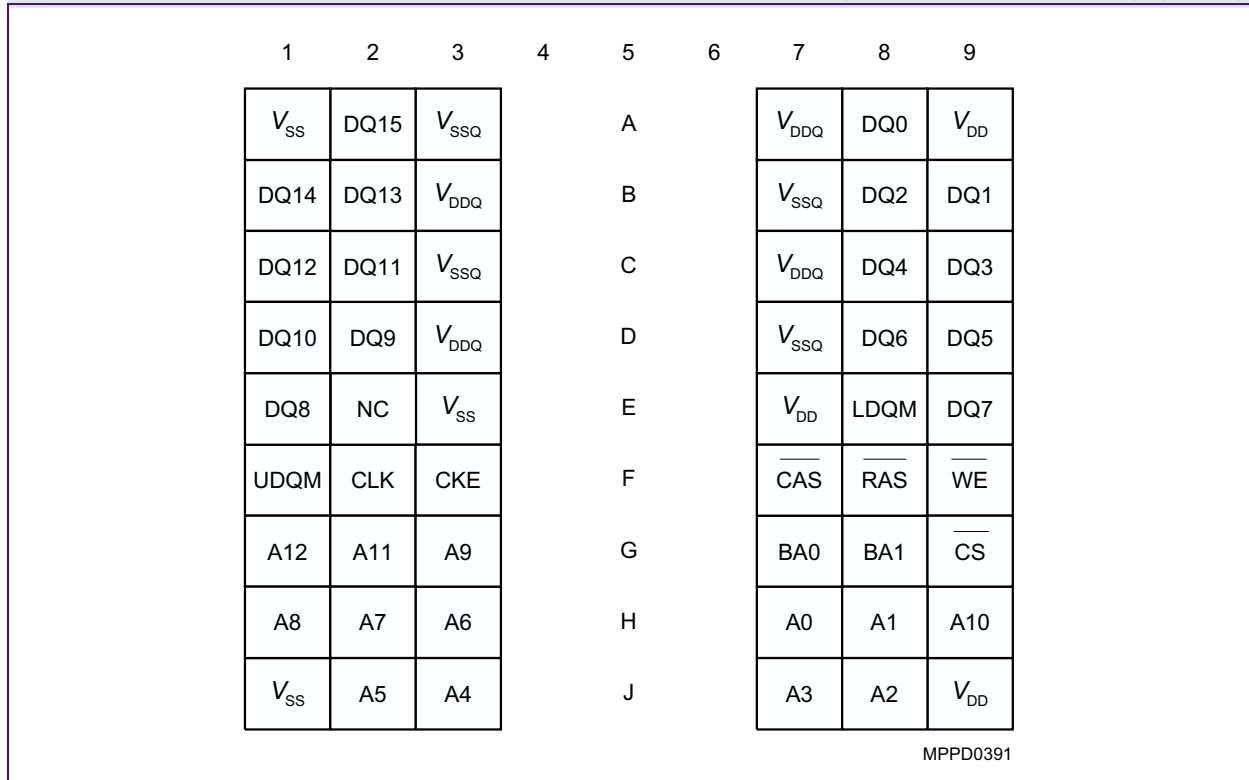



HY[B/I]39SC256[80/16]0F[E/F]
256-MBit Synchronous DRAM

FIGURE 3

Ballout for ×8 components, PG-TFBGA-54 (top view)

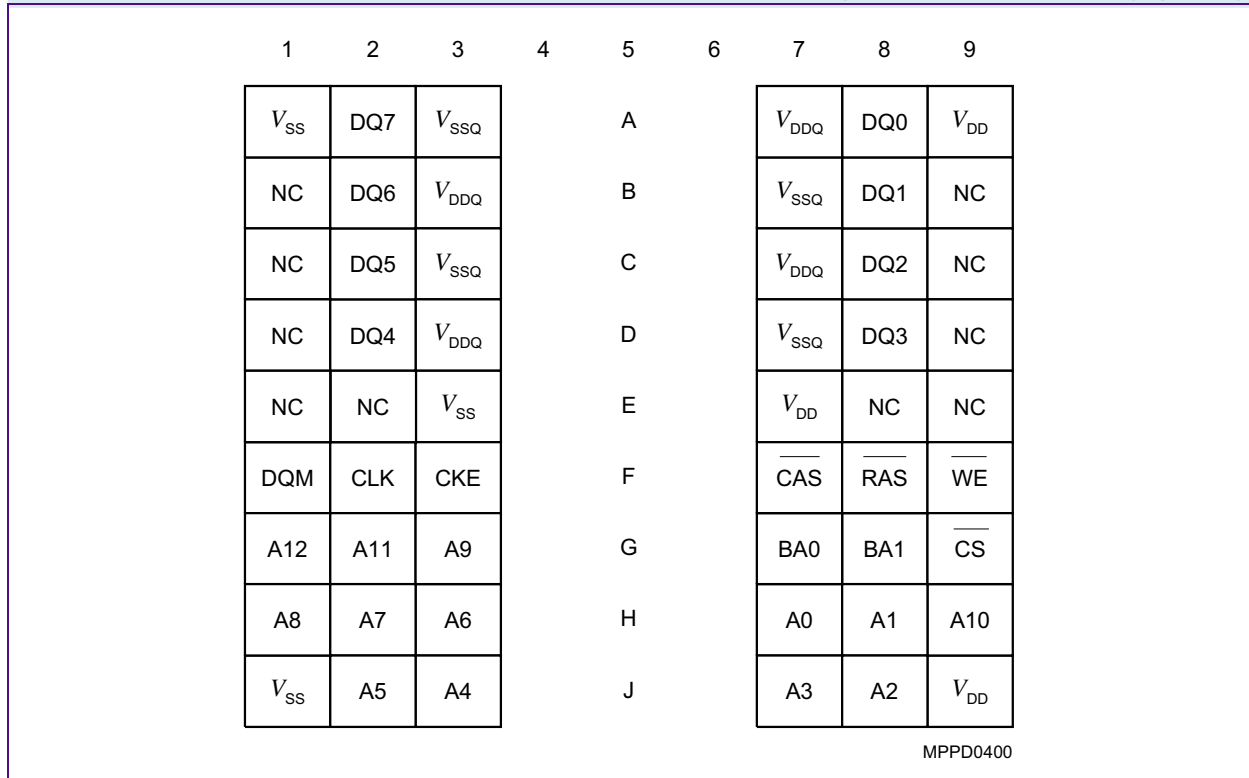



3 Functional Description

This chapter lists all defined commands and their usage for this Synchronous DRAM.

TABLE 4
Truth Table: Operation Command

Operation	Device State	CKE _{n-1} ¹⁾²⁾	CKE _n ¹⁾²⁾	DQM ₁₎₂₎	BA0 BA1 ¹⁾²⁾	AP= A10 ¹⁾²⁾	Addr. ₁₎₂₎	CS ¹ ₂₎	RAS ₁₎₂₎	CAS ¹ ₂₎	WE ₁₎₂₎
Bank Active	Idle ³⁾	H	X	X	V	V	V	L	L	H	H
Bank Precharge	Any	H	X	X	V	L	X	L	L	H	L
Precharge All	Any	H	X	X	X	H	X	L	L	H	L
Write	Active ³⁾	H	X	X	V	L	V	L	H	L	L
Write with Auto precharge	Active ³⁾	H	X	X	V	H	V	L	H	L	L
Read	Active ³⁾	H	X	X	V	L	V	L	H	L	H
Read with Auto precharge	Active ³⁾	H	X	X	V	H	V	L	H	L	H
Mode Register Set	Idle	H	X	X	V	V	V	L	L	L	L
No Operation	Any	H	X	X	X	X	X	L	H	H	H
Burst Stop	Active	H	X	X	X	X	X	L	H	H	L
Device Deselect	Any	H	X	X	X	X	X	H	X	X	X
Auto Refresh	Idle	H	H	X	X	X	X	L	L	L	H
Self Refresh Entry	Idle	H	L	X	X	X	X	L	L	L	H
Self Refresh Exit	Idle (Self Refr.)	L	H	X	X	X	X	H	X	X	X
								L	H	H	X
Power Down/ Clock Suspend Entry	Active or Idle or Burst	H	L	X	X	X	X	H	X	X	X
								L	H	H	H
Power Down/ Clock Suspend Exit	Active or Idle or Burst	L	H	X	X	X	X	H	X	X	X
								L	H	H	H
Data Write/ Output Enable	Active	H	X	L	X	X	X	X	X	X	X
Data Write/ Output Disable	Active	H	X	H	X	X	X	X	X	X	X

- 1) V = Valid, x = Don't Care, L = Low Level, H = High Level
- 2) CKEn signal is input level when commands are provided, CKEn-1 signal is input level one clock before the commands are provided.
- 3) This is the state of the banks designated by BA0, BA1 signals.



HY[B/I]39SC256[80/16]0F[E/F]
256-MBit Synchronous DRAM

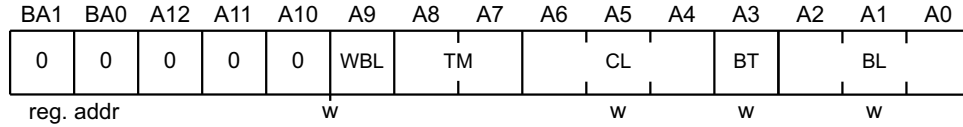

MPBS0001

TABLE 5
Mode Register Definition (BA[1:0] = 00_B)

Field	Bits	Type	Description
BL	[2:0]	w	Burst Length Number of sequential bits per DQ related to one read/write command, see Table 6 <i>Note: All other bit combinations are RESERVED</i> 000 _B 1 001 _B 2 010 _B 4 011 _B 8 111 _B Full Page (Sequential burst type only)
BT	3		Burst Type 0 _B Sequential 1 _B Interleaved
CL	[6:4]		CAS Latency Number of full clocks from read command to first data valid window. <i>Note: All other bit combinations are RESERVED.</i> 010 _B 2 011 _B 3
TM	[8:7]		Test Mode <i>Note: All other bit combinations are RESERVED.</i> 00 _B Mode register set
WBL	9		Write Burst Length 0 _B Burst write 1 _B Single bit write
	[12:10]		Reserved, set to zero



TABLE 6
Burst Length and Sequence

Burst Length	Starting Column Address			Order of Accesses Within a Burst	
	A2	A1	A0	Type=Sequential	Type=Interleaved
2			0	0-1	0-1
			1	1-0	1-0
4		0	0	0-1-2-3	0-1-2-3
		0	1	1-2-3-0	1-0-3-2
		1	0	2-3-0-1	2-3-0-1
		1	1	3-0-1-2	3-2-1-0
8	0	0	0	0-1-2-3-4-5-6-7	0-1-2-3-4-5-6-7
	0	0	1	1-2-3-4-5-6-7-0	1-0-3-2-5-4-7-6
	0	1	0	2-3-4-5-6-7-0-1	2-3-0-1-6-7-4-5
	0	1	1	3-4-5-6-7-0-1-2	3-2-1-0-7-6-5-4
	1	0	0	4-5-6-7-0-1-2-3	4-5-6-7-0-1-2-3
	1	0	1	5-6-7-0-1-2-3-4	5-4-7-6-1-0-3-2
	1	1	0	6-7-0-1-2-3-4-5	6-7-4-5-2-3-0-1
	1	1	1	7-0-1-2-3-4-5-6	7-6-5-4-3-2-1-0
FullPage	n			Cn, Cn+1, Cn+2	Not supported

Notes

1. For a burst length of two, A1-Ai selects the two-data-element block; A0 selects the first access within the block.
2. For a burst length of four, A2-Ai selects the four-data-element block; A0-A1 selects the first access within the block.
3. For a burst length of eight, A3-Ai selects the eight-data- element block; A0-A2 selects the first access with in the block.
4. Whenever a boundary of the block is reached within a given sequence above, the following access wraps within the block.



4 Electrical Characteristics

4.1 Operating Conditions

TABLE 7
Absolute Maximum Ratings

Parameter	Symbol	Limit Values		Unit	Note/ Test Condition
		Min.	Max.		
Input / Output voltage relative to V_{SS}	V_{IN}, V_{OUT}	-1.0	+4.6	V	
Voltage on V_{DD} supply relative to V_{SS}	V_{DD}	-1.0	+4.6	V	
Voltage on V_{DDQ} supply relative to V_{SS}	V_{DDQ}	-1.0	+4.6	V	
Operating Temperature for HYB...	T_A	0	+70	°C	
Operating Temperature for HYI...	T_A	-40	+85	°C	
Storage temperature range	T_{STG}	-55	+150	°C	
Power dissipation per SDRAM component	P_D	—	1	W	
Data out current (short circuit)	I_{OUT}	—	50	mA	

Attention: Stresses above the max. values listed here may cause permanent damage to the device. Exposure to absolute maximum rating conditions for extended periods may affect device reliability. Maximum ratings are absolute ratings; exceeding only one of these values may cause irreversible damage to the integrated circuit.



TABLE 8
DC Characteristics

Parameter	Symbol	Values		Unit	Note/ Test Condition
		Min.	Max.		
Supply Voltage	V_{DD}	3.0	3.6	V	1)
I/O Supply Voltage	V_{DDQ}	3.0	3.6	V	1)
Input high voltage	V_{IH}	2.0	$V_{DDQ} + 0.3$	V	1)2)
Input low voltage	V_{IL}	-0.3	+0.8	V	1)2)
Output high voltage ($I_{OUT} = -4.0$ mA)	V_{OH}	2.4	—	V	1)
Output low voltage ($I_{OUT} = 4.0$ mA)	V_{OL}	—	0.4	V	1)
Input leakage current, any input ($0\text{ V} < V_{IN} < V_{DD}$, all other inputs = 0 V)	I_{IL}	-5	+5	μA	
Output leakage current (DQs are disabled, $0\text{ V} < V_{OUT} < V_{DDQ}$)	I_{OL}	-5	+5	μA	

- 1) All voltages are referenced to V_{SS}
 2) V_{IH} may overshoot to $V_{DDQ} + 2.0$ V for pulse width of < 4 ns with 3.3 V. V_{IL} may undershoot to -2.0 V for pulse width < 4.0 ns with 3.3 V. Pulse width measured at 50% points with amplitude measured peak to DC reference.

TABLE 9
Input and Output Capacitances

Parameter	Symbol	Values		Unit	Note
		Min.	Max.		
Input Capacitances: CK	C_{I1}	2.5	3.5	pF	1)2)
Input Capacitance (A0-A12, BA0, BA1, $\overline{\text{RAS}}$, $\overline{\text{CAS}}$, $\overline{\text{WE}}$, $\overline{\text{CS}}$, CKE, DQM)	C_{I2}	2.5	3.8	pF	1)2)
Input/Output Capacitance (DQ)	C_{I0}	4.0	6.0	pF	1)2)

- 1) $V_{DD}, V_{DDQ} = 3.3\text{ V} \pm 0.3\text{ V}$, $f = 1\text{ MHz}$, T_A see **Table 7**
 2) Capacitance values are shown for TSOP-54 packages. Capacitance values for TFBGA packages are lower by 0.5 pF

TABLE 10
 I_{DD} Conditions

Parameter	Symbol
Operating Current	One bank active, Burst length = 1 I_{DD1}
Precharge Standby Current	Power down mode I_{DD2P}
	Non-power down mode I_{DD2N}
No Operating Current	Active state (max. 4 banks) I_{DD3N}
	I_{DD3P}
Burst Operating Current	Read command cycling I_{DD4}
Auto Refresh Current	Auto Refresh command cycling I_{DD5}
Self Refresh Current	Self Refresh Mode, CKE=0.2 V, $t_{CK}=\text{infinity}$ I_{DD6}



TABLE 11
 I_{DD} Specifications and Conditions

Symbol	Test Condition	-6	-7	Unit	Note ¹⁾
I_{DD1}	$t_{RC} = t_{RC(min)}$, $I_O = 0$ mA	100	80	mA	2)3)
I_{DD2P}	$\overline{CS} = V_{IH(min)}$, $CKE \leq V_{IL(max)}$	2	2	mA	1)
I_{DD2N}	$\overline{CS} = V_{IH(min)}$, $CKE \geq V_{IH(min)}$	26	22	mA	1)
I_{DD3N}	$CS = V_{IH(min)}$, $CKE \geq V_{IH(min)}$	40	35	mA	1)
I_{DD3P}	$CS = V_{IH(min)}$, $CKE \leq V_{IL(max)}$	5	5	mA	1)
I_{DD4}	—	65	57	mA	1)3)
I_{DD5}	$t_{RFC} = t_{RFC(min)}$	168	142	mA	4)
	$t_{RFC} = 15.6 \mu s$	25	25	mA	
I_{DD6}	—	3	3	mA	

- 1) $V_{SS} = 0$ V; V_{DD} , $V_{DDQ} = 3.3$ V \pm 0.3 V, T_A see **Table 7**
- 2) These parameters depend on the cycle rate. All values are measured at 133 MHz for -7 with the outputs open. Input signals are changed once during t_{CK} .
- 3) These parameters are measured with continuous data stream during read access and all DQ toggling. CL=3 and BL=4 is assumed and the V_{DDQ} current is excluded.
- 4) $t_{RFC} = t_{RFC(min)}$ "burst refresh", $t_{RFC} = 15.6 \mu s$ "distributed refresh".



4.2 AC Characteristics

TABLE 12
AC Timing - Absolute Specifications

Parameter	Symbol	-7		-6		Unit	Note ¹⁾²⁾³⁾
		PC143-333		PC166-333			
		Min.	Max.	Min.	Max.		
Clock and Clock Enable							
Clock Frequency	t_{CK}	7 7.5	—	6 7.5	—	ns ns	CL3 CL2
Access Time from Clock	t_{AC}	— —	5.4 5.4	— —	5.4 5.4	ns ns	CL3 CL2 3)4)5)
Clock High Pulse Width	t_{CH}	2.5	—	2	—	ns	
Clock Low Pulse Width	t_{CL}	2.5	—	2	—	ns	
Transition time	t_T	0.3	1.2	0.3	1.2	ns	
Setup and Hold Times							
Input Setup Time	t_{IS}	1.5	—	1.5	—	ns	6)
Input Hold Time	t_{IH}	0.8	—	0.8	—	ns	6)
CKE Setup Time	t_{CKS}	1.5	—	1.5	—	ns	6)
CKE Hold Time	t_{CKH}	0.8	—	0.8	—	ns	6)
Mode Register Set-up to Active delay	t_{RSC}	2	—	2	—	t_{CK}	
Power Down Mode Entry Time	t_{SB}	0	7	0	6	ns	
Common Parameters							
Row to Column Delay Time	t_{RCD}	15	—	15	—	ns	7)
Row Precharge Time	t_{RP}	15	—	15	—	ns	7)
Row Active Time	t_{RAS}	37	100k	36	100k	ns	7)
Row Cycle Time	t_{RC}	60	—	60	—	ns	7)
Row Cycle Time during Auto Refresh	t_{RFC}	63	—	60	—	ns	
Activate(a) to Activate(b) Command period	t_{RRD}	14	—	12	—	ns	7)
CAS(a) to CAS(b) Command period	t_{CCD}	1	—	1	—	t_{CK}	
Refresh Cycle							
Refresh Period (8192 cycles)	t_{REF}	—	64	—	64	ms	
Self Refresh Exit Time	t_{SREX}	1	—	1	—	t_{CK}	
Data Out Hold Time	t_{OH}	3	—	2.5	—	ns	3)5)
Read Cycle							
Data Out to Low Impedance Time	t_{LZ}	0	—	0	—	ns	
Data Out to High Impedance Time	t_{HZ}	3	7	3	6	ns	
DQM Data Out Disable Latency	t_{DQZ}	—	2	—	2	t_{CK}	



HY[B/I]39SC256[80/16]0F[E/F]
256-MBit Synchronous DRAM

Parameter	Symbol	-7		-6		Unit	Note ¹⁾²⁾³⁾
		PC143-333		PC166-333			
		Min.	Max.	Min.	Max.		
Write Cycle							
Last Data Input to Precharge (Write without Auto Precharge)	t_{WR}	14	—	12	—	ns	8)
Last Data Input to Activate (Write with Auto Precharge)	$t_{DAL(min.)}$	—	—	—	—	t_{CK}	9)
DQM Write Mask Latency	t_{DQW}	0	—	0	—	t_{CK}	

- 1) $T_A = 0$ to 70 °C; $V_{SS} = 0$ V; $V_{DD}, V_{DDQ} = 3.3$ V \pm 0.3 V, $t_T = 1$ ns
- 2) For proper power-up see the operation section of this data sheet.
- 3) AC timing tests for LV-TTL versions have $V_{IL} = 0.4$ V and $V_{IH} = 2.4$ V with the timing referenced to the 1.4 V crossover point. The transition time is measured between V_{IH} and V_{IL} . All AC measurements assume $t_T = 1$ ns with the AC output load circuit shown in figure below. Specified t_{AC} and t_{OH} parameters are measured with a 50 pF only, without any resistive termination and with an input signal of 1V / ns edge rate between 0.8 V and 2.0 V.
- 4) If clock rising time is longer than 1 ns, a time $(t_r/2 - 0.5)$ ns has to be added to this parameter.
- 5) Access time from clock t_{ac} is 4.6 ns for PC133 components with no termination and 0 pF load, Data out hold time t_{oh} is 1.8 ns for PC133 components with no termination and 0 pF load.
- 6) If t_T is longer than 1 ns, a time $(t_T - 1)$ ns has to be added to this parameter.
- 7) These parameter account for the number of clock cycles and depend on the operating frequency of the clock, as follows:
the number of clock cycles = specified value of timing period (counted in fractions as a whole number)
- 8) It is recommended to use two clock cycles between the last data-in and the precharge command in case of a write command without Auto-Precharge. One clock cycle between the last data-in and the precharge command is also supported, but restricted to cycle times t_{CK} greater or equal the specified t_{WR} value, where t_{ck} is equal to the actual system clock time.
- 9) When a Write command with Auto Precharge has been issued, a time of $t_{DAL(min)}$ has to be fulfilled before the next Activate Command can be applied. For each of the terms, if not already an integer, round up to the next highest integer. t_{CK} is equal to the actual system clock time.

FIGURE 4
Measurement conditions for t_{AC} and t_{OH}

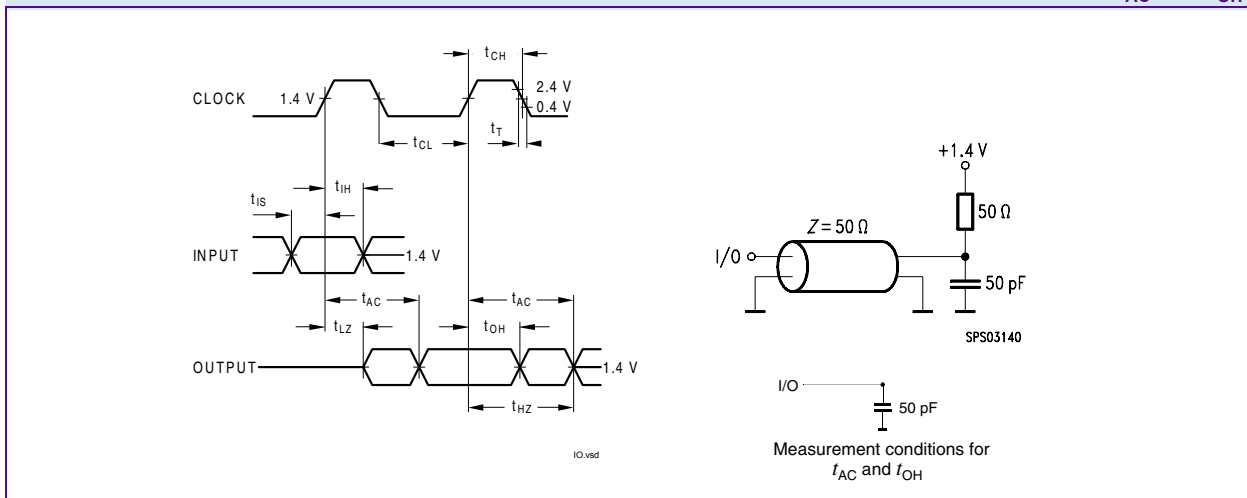

HY[B/I]39SC256[80/16]0F[E/F]
256-MBit Synchronous DRAM

5 Package Outlines

FIGURE 5
Package Outline PG-TSOPII-54 (top view)

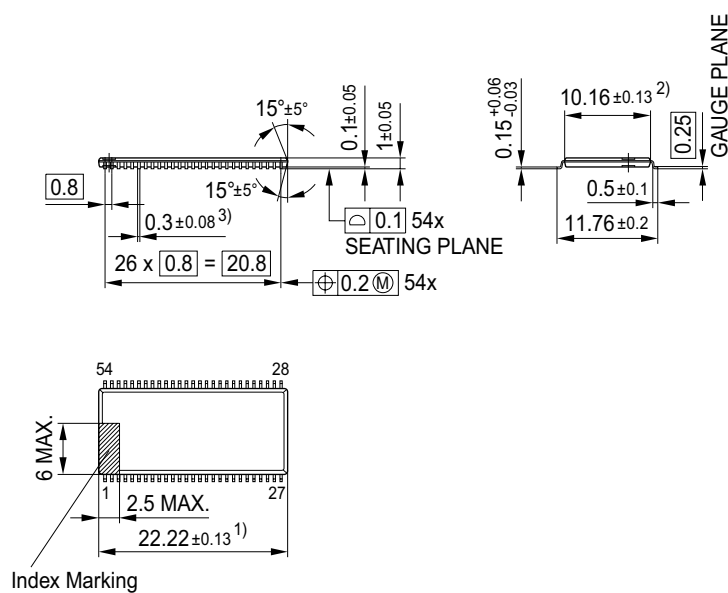

- Index Marking
- 1) Does not include plastic or metal protrusion of 0.15 max. per side
 - 2) Does not include plastic protrusion of 0.25 max. per side
 - 3) Does not include dambar protrusion of 0.13 max. per side

GPX01088



HY[B/I]39SC256[80/16]0F[E/F]
256-MBit Synchronous DRAM

FIGURE 6
Package Outline PG-TFBGA-54-15

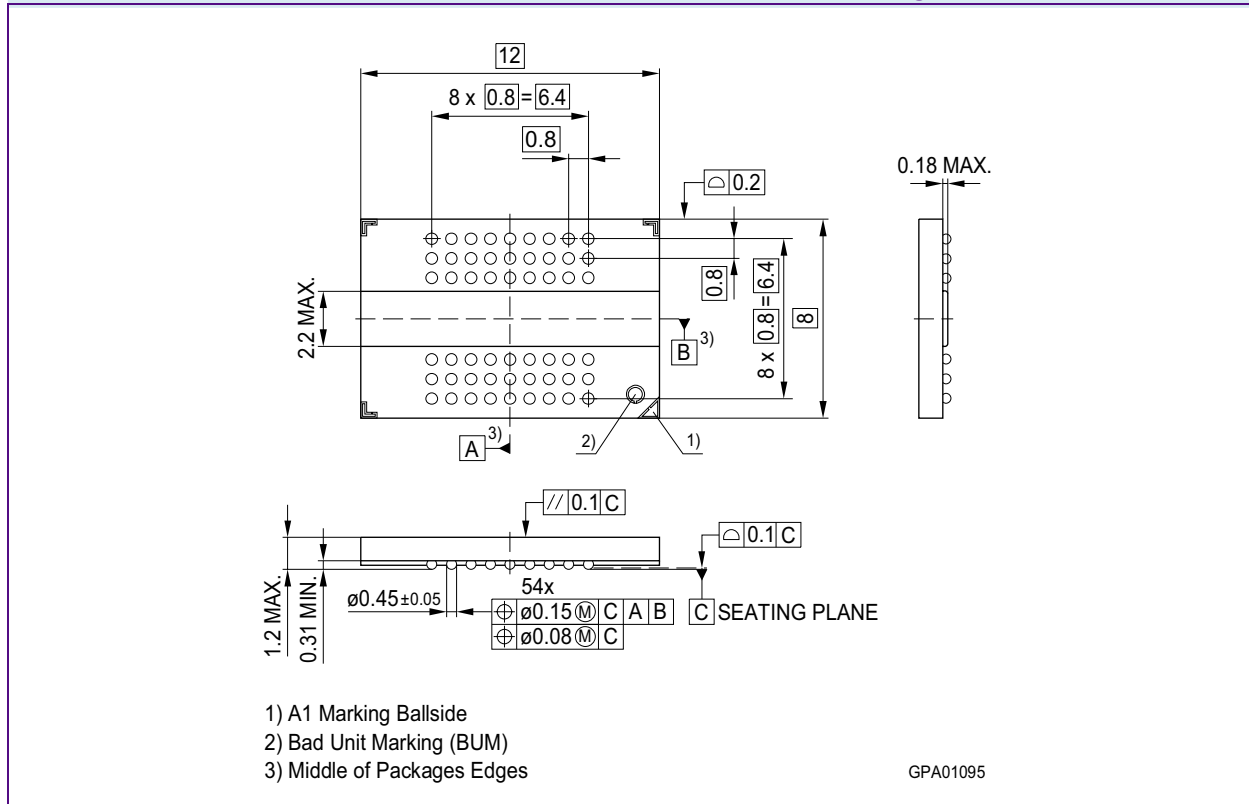

Notes

1. Drawing according to ISO 8015
2. Dimensions in mm
3. General tolerances +/- 0.15



6 Product Nomenclature

For reference the Qimonda SDRAM component nomenclature is enclosed in this chapter.

TABLE 13
Examples for Nomenclature Fields

Example for	Field Number										
	1	2	3	4	5	6	7	8	9	10	11
SDRAM	HYB	39	SC	256	80		0	F	F	—	-6
SDRAM	HYI	39	SC	256	16		0	F	E	—	-7

TABLE 14
Memory Components

Field	Description	Values	Coding
1	Qimonda Component Prefix	HYB	Memory components
		HYI	Memory components, industrial temperature range (-40 °C – +85 °C)
2	Interface Voltage [V]	39	3.3 V
3	DRAM Technology	SC	Single Data Rate SDRAM Consumer Product
4	Component Density [Mbit]	128	128 Mbit
		256	256 Mbit
		512	512 Mbit
5+6	Number of I/Os	40	×4
		80	×8
		16	×16
7	Product Variations	0 .. 9	look up table
8	Die Revision	C	Third
		D	Fourth
		F	Fifth
9	Package, Lead-Free Status	E	TSOP, lead- and halogen-free
		F	FBGA, lead- and halogen-free
10	Power	—	Standard power product
11	Speed Grade	-6	PC166-333
		-7	PC143-333, PC133-222



List of Figures

Figure 1	Pin Configuration PG-TSOPII-54	7
Figure 2	Ballout for $\times 16$ Components, PG-TFBGA-54 (top view)	8
Figure 3	Ballout for $\times 8$ components, PG-TFBGA-54 (top view)	9
Figure 4	Measurement conditions for t_{AC} and t_{OH}	17
Figure 5	Package Outline PG-TSOPII-54 (top view)	18
Figure 6	Package Outline PG-TFBGA-54-15	19



List of Tables

Table 1	Performance	3
Table 2	Ordering Information for RoHS Compliant Products	4
Table 3	Pin Configuration of the SDRAM	5
Table 4	Truth Table: Operation Command	10
Table 5	Mode Register Definition (BA[1:0] = 00 _B)	11
Table 6	Burst Length and Sequence	12
Table 7	Absolute Maximum Ratings	13
Table 8	DC Characteristics	14
Table 9	Input and Output Capacitances	14
Table 10	I_{DD} Conditions	14
Table 11	I_{DD} Specifications and Conditions	15
Table 12	AC Timing - Absolute Specifications	16
Table 13	Examples for Nomenclature Fields	20
Table 14	Memory Components	20



Table of Contents

1	Overview	3
1.1	Features	3
1.2	Description	4
2	Configuration	5
2.1	Pin Configuration	5
3	Functional Description	10
4	Electrical Characteristics	13
4.1	Operating Conditions	13
4.2	AC Characteristics	16
5	Package Outlines	18
6	Product Nomenclature	20
	List of Figures	21
	List of Tables	22
	Table of Contents	23

Edition 2007-06

**Published by Qimonda AG
Gustav-Heinemann-Ring 212
D-81739 München, Germany
© Qimonda AG 2007.
All Rights Reserved.**

Legal Disclaimer

The information given in this Internet Data Sheet shall in no event be regarded as a guarantee of conditions or characteristics ("Beschaffenheitsgarantie"). With respect to any examples or hints given herein, any typical values stated herein and/or any information regarding the application of the device, Qimonda hereby disclaims any and all warranties and liabilities of any kind, including without limitation warranties of non-infringement of intellectual property rights of any third party.

Information

For further information on technology, delivery terms and conditions and prices please contact your nearest Qimonda Office.

Warnings

Due to technical requirements components may contain dangerous substances. For information on the types in question please contact your nearest Qimonda Office.

Under no circumstances may the Qimonda product as referred to in this Internet Data Sheet be used in

1. Any applications that are intended for military usage (including but not limited to weaponry), or
2. Any applications, devices or systems which are safety critical or serve the purpose of supporting, maintaining, sustaining or protecting human life (such applications, devices and systems collectively referred to as "Critical Systems"), if
 - a) A failure of the Qimonda product can reasonable be expected to - directly or indirectly -
 - (i) Have a detrimental effect on such Critical Systems in terms of reliability, effectiveness or safety; or
 - (ii) Cause the failure of such Critical Systems; or
 - b) A failure or malfunction of such Critical Systems can reasonably be expected to - directly or indirectly -
 - (i) Endanger the health or the life of the user of such Critical Systems or any other person; or
 - (ii) Otherwise cause material damages (including but not limited to death, bodily injury or significant damages to property, whether tangible or intangible).

www.qimonda.com