

2 Mbit (128Kb x16) Low Voltage UV EPROM and OTP EPROM

- 2.7V to 3.6V SUPPLY VOLTAGE in READ OPERATION
- ACCESS TIME:
 - 80ns at $V_{CC} = 3.0V$ to 3.6V
 - 100ns at $V_{CC} = 2.7V$ to 3.6V
- LOW POWER CONSUMPTION:
 - Active Current 20mA at 5MHz
 - Standby Current 15 μ A
- PIN COMPATIBLE with M27C202
- PROGRAMMING TIME: 100 μ s/word
- HIGH RELIABILITY CMOS TECHNOLOGY
 - 2,000V ESD Protection
 - 200mA Latchup Protection Immunity
- ELECTRONIC SIGNATURE
 - Manufacturer Code: 0020h
 - Device Code: 001Ch

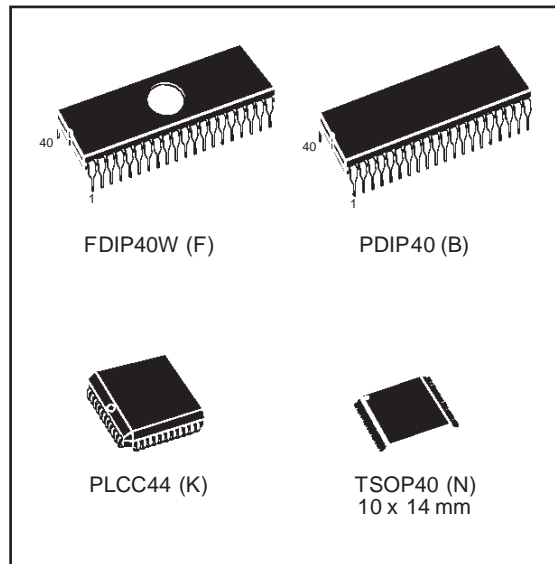
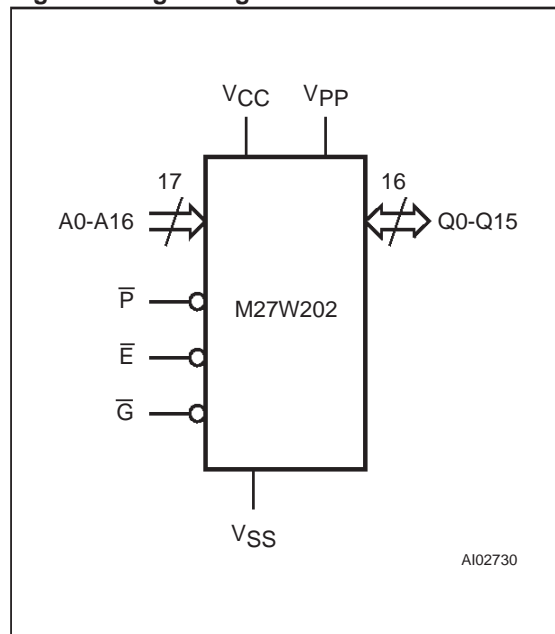

Figure 1. Logic Diagram



DESCRIPTION

The M27W202 is a low voltage 2 Mbit EPROM offered in the two range UV (ultra violet erase) and OTP (one time programmable). It is ideally suited for microprocessor systems requiring large data or program storage and is organised as 131,072 by 16 bits.

The M27W202 operates in the read mode with a supply voltage as low as 2.7V at -40 to $85^{\circ}C$ temperature range. The decrease in operating power allows either a reduction of the size of the battery or an increase in the time between battery recharges.

The FDIP40W (window ceramic frit-seal package) has a transparent lid which allows the user to expose the chip to ultraviolet light to erase the bit pattern. A new pattern can then be written to the device by following the programming procedure.

For application where the content is programmed only one time and erasure is not required, the M27W201 is offered in PDIP40, PLCC44 and TSOP40 (10 x 14 mm) packages.

Table 2. Absolute Maximum Ratings (1)

Symbol	Parameter	Value	Unit
T _A	Ambient Operating Temperature (3)	-40 to 125	°C
T _{BIAS}	Temperature Under Bias	-50 to 125	°C
T _{STG}	Storage Temperature	-65 to 150	°C
V _{IO} (2)	Input or Output Voltage (except A9)	-2 to 7	V
V _{CC}	Supply Voltage	-2 to 7	V
V _{A9} (2)	A9 Voltage	-2 to 13.5	V
V _{PP}	Program Supply Voltage	-2 to 14	V

Note: 1. Except for the rating "Operating Temperature Range", stresses above those listed in the Table "Absolute Maximum Ratings" may cause permanent damage to the device. These are stress ratings only and operation of the device at these or any other conditions above those indicated in the Operating sections of this specification is not implied. Exposure to Absolute Maximum Rating conditions for extended periods may affect device reliability. Refer also to the STMicroelectronics SURE Program and other relevant quality documents.

2. Minimum DC voltage on Input or Output is -0.5V with possible undershoot to -2.0V for a period less than 20ns. Maximum DC voltage on Output is V_{CC} +0.5V with possible overshoot to V_{CC} +2V for a period less than 20ns.

3. Depends on range.

Table 3. Operating Modes

Mode	\bar{E}	\bar{G}	\bar{P}	A9	V _{PP}	Q15-Q0
Read	V _{IL}	V _{IL}	V _{IH}	X	V _{CC} or V _{SS}	Data Output
Output Disable	V _{IL}	V _{IH}	X	X	V _{CC} or V _{SS}	Hi-Z
Program	V _{IL}	X	V _{IL} Pulse	X	V _{PP}	Data Input
Verify	V _{IL}	V _{IL}	V _{IH}	X	V _{PP}	Data Output
Program Inhibit	V _{IH}	X	X	X	V _{PP}	Hi-Z
Standby	V _{IH}	X	X	X	V _{CC} or V _{SS}	Hi-Z
Electronic Signature	V _{IL}	V _{IL}	V _{IH}	V _{ID}	V _{CC}	Codes

Note: X = V_{IH} or V_{IL}, V_{ID} = 12V ± 0.5V.

Table 4. Electronic Signature

Identifier	A0	Q7	Q6	Q5	Q4	Q3	Q2	Q1	Q0	Hex Data
Manufacturer's Code	V _{IL}	0	0	1	0	0	0	0	0	20h
Device Code	V _{IH}	0	0	0	1	1	1	0	0	1Ch

Note: Outputs Q15-Q8 are set to '0'.

Table 5. AC Measurement Conditions

	High Speed	Standard
Input Rise and Fall Times	≤ 10ns	≤ 20ns
Input Pulse Voltages	0 to 3V	0.4V to 2.4V
Input and Output Timing Ref. Voltages	1.5V	0.8V and 2V

Figure 3. AC Testing Input Output Waveform

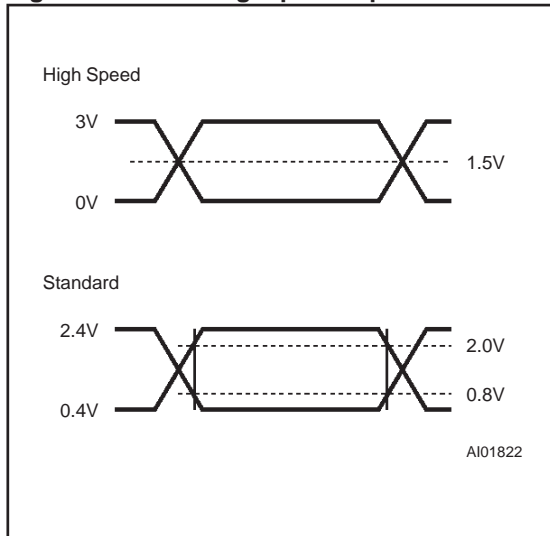

Figure 4. AC Testing Load Circuit

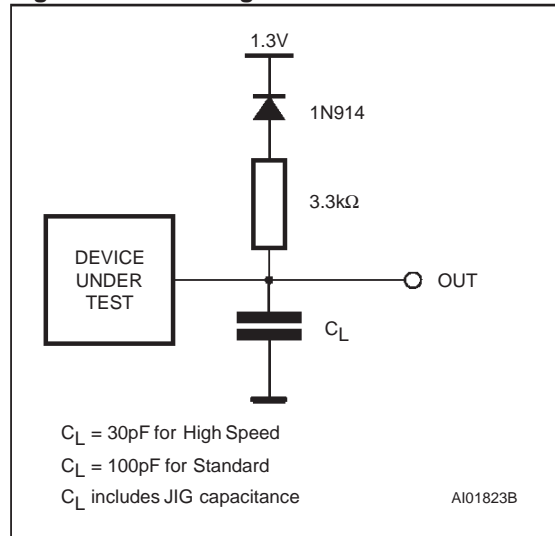

Table 6. Capacitance ⁽¹⁾ (T_A = 25 °C, f = 1 MHz)

Symbol	Parameter	Test Condition	Min	Max	Unit
C _{IN}	Input Capacitance	V _{IN} = 0V		6	pF
C _{OUT}	Output Capacitance	V _{OUT} = 0V		12	pF

Note: 1. Sampled only, not 100% tested.

DEVICE OPERATION

The operating modes of the M27W202 are listed in the Operating Modes table. A single power supply is required in the read mode. All inputs are TTL levels except for V_{PP} and 12V on A9 for Electronic Signature.

Read Mode

The M27W202 has two control functions, both of which must be logically active in order to obtain data at the outputs. Chip Enable (\bar{E}) is the power control and should be used for device selection. Output Enable (\bar{G}) is the output control and should be used to gate data to the output pins, independent of device selection. Assuming that the addresses are stable, the address access time

(t_{AVQV}) is equal to the delay from \bar{E} to output (t_{ELQV}). Data is available at the output after a delay of t_{OE} from the falling edge of \bar{G} , assuming that \bar{E} has been low and the addresses have been stable for at least t_{AVQV}-t_{GLQV}.

Standby Mode

The M27W202 has a standby mode which reduces the supply current from 15mA to 15μA with low voltage operation V_{CC} ≈ 3.6V, see Read Mode DC Characteristics table for details.

The M27W202 is placed in the standby mode by applying a TTL high signal to the \bar{E} input. When in the standby mode, the outputs are in a high impedance state, independent of the \bar{G} input.

Table 7. Read Mode DC Characteristics (1)
 ($T_A = -40$ to 85 °C; $V_{CC} = 2.7V$ to $3.6V$; $V_{PP} = V_{CC}$)

Symbol	Parameter	Test Condition	Min	Max	Unit
I_{LI}	Input Leakage Current	$0V \leq V_{IN} \leq V_{CC}$		± 10	μA
I_{LO}	Output Leakage Current	$0V \leq V_{OUT} \leq V_{CC}$		± 10	μA
I_{CC}	Supply Current	$\bar{E} = V_{IL}, \bar{G} = V_{IL},$ $I_{OUT} = 0mA, f = 5MHz$ $V_{CC} \leq 3.6V$		20	mA
I_{CC1}	Supply Current (Standby) TTL	$\bar{E} = V_{IH}$		1	mA
I_{CC2}	Supply Current (Standby) CMOS	$\bar{E} > V_{CC} - 0.2V$ $V_{CC} \leq 3.6V$		15	μA
I_{PP}	Program Current	$V_{PP} = V_{CC}$		10	μA
V_{IL}	Input Low Voltage		-0.6	$0.2 V_{CC}$	V
$V_{IH}^{(2)}$	Input High Voltage		$0.7 V_{CC}$	$V_{CC} + 0.5$	V
V_{OL}	Output Low Voltage	$I_{OL} = 2.1mA$		0.4	V
V_{OH}	Output High Voltage TTL	$I_{OH} = -400\mu A$	2.4		V

Note: 1. V_{CC} must be applied simultaneously with or before V_{PP} and removed simultaneously or after V_{PP} .
 2. Maximum DC voltage on Output is $V_{CC} + 0.5V$.

Two Line Output Control

Because OTP EPROMs are usually used in larger memory arrays, this product features a 2 line control function which accommodates the use of multiple memory connection. The two line control function allows:

- the lowest possible memory power dissipation,
- complete assurance that output bus contention will not occur.

For the most efficient use of these two control lines, \bar{E} should be decoded and used as the primary device selecting function, while \bar{G} should be made a common connection to all devices in the array and connected to the \overline{READ} line from the system control bus. This ensures that all deselected memory devices are in their low power standby mode and that the output pins are only active when data is required from a particular memory device.

System Considerations

The power switching characteristics of Advanced CMOS EPROMs require careful decoupling of the devices. The supply current, I_{CC} , has three segments that are of interest to the system designer: the standby current level, the active current level, and transient current peaks that are produced by the falling and rising edges of \bar{E} . The magnitude of transient current peaks is dependent on the capacitive and inductive loading of the device at the output. The associated transient voltage peaks can be suppressed by complying with the two line output control and by properly selected decoupling capacitors. It is recommended that a $0.1\mu F$ ceramic capacitor be used on every device between V_{CC} and V_{SS} . This should be a high frequency capacitor of low inherent inductance and should be placed as close to the device as possible. In addition, a $4.7\mu F$ bulk electrolytic capacitor should be used between V_{CC} and V_{SS} for every eight devices. The bulk capacitor should be located near the power supply connection point. The purpose of the bulk capacitor is to overcome the voltage drop caused by the inductive effects of PCB traces.

Table 8. Read Mode AC Characteristics (1)
 (TA = -40 to 85 °C; VCC = 2.7V to 3.6V; VPP = VCC)

Symbol	Alt	Parameter	Test Condition	M27W202						Unit
				-100 (3)				-120 (-150/-200)		
				VCC = 3.0V to 3.6V		VCC = 2.7V to 3.6V		VCC = 2.7V to 3.6V		
				Min	Max	Min	Max	Min	Max	
tAVQV	tACC	Address Valid to Output Valid	$\overline{E} = V_{IL}$, $\overline{G} = V_{IL}$		80		100		120	ns
tELQV	tCE	Chip Enable Low to Output Valid	$\overline{G} = V_{IL}$		80		100		120	ns
tGLQV	tOE	Output Enable Low to Output Valid	$\overline{E} = V_{IL}$		50		60		70	ns
tEHQZ (2)	tDF	Chip Enable High to Output Hi-Z	$\overline{G} = V_{IL}$	0	50	0	60	0	70	ns
tGHQZ (2)	tDF	Output Enable High to Output Hi-Z	$\overline{E} = V_{IL}$	0	50	0	60	0	70	ns
tAXQX	tOH	Address Transition to Output Transition	$\overline{E} = V_{IL}$, $\overline{G} = V_{IL}$	0		0		0		ns

Note: 1. VCC must be applied simultaneously with or before VPP and removed simultaneously or after VPP.
 2. Sampled only, not 100% tested.
 3. Speed obtained with High Speed AC measurement conditions.

Figure 5. Read Mode AC Waveforms

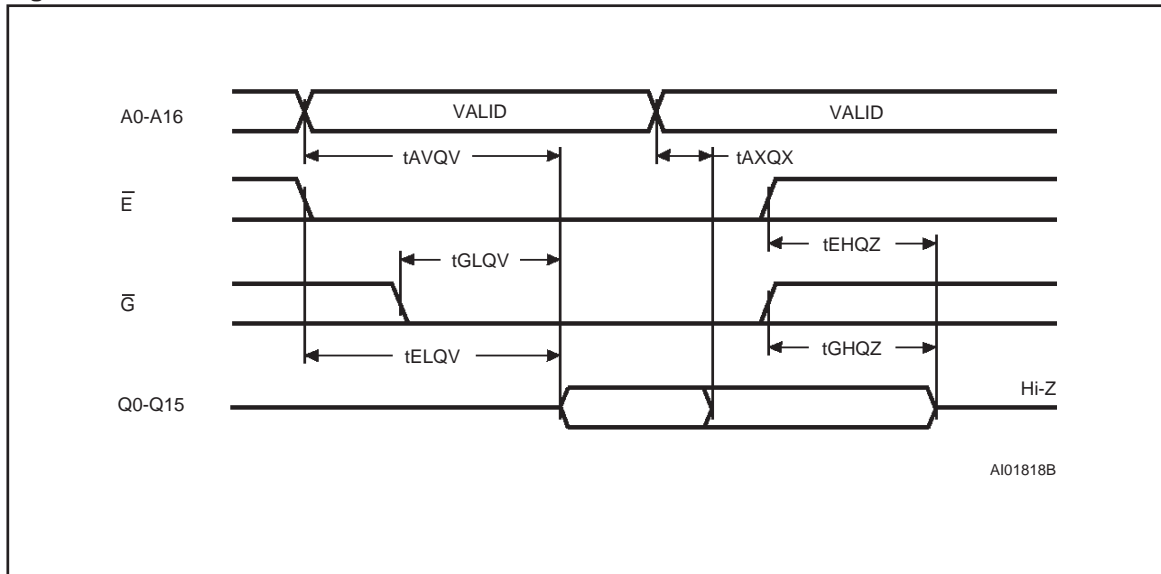

Table 9. Programming Mode DC Characteristics (1)
 (T_A = 25 °C; V_{CC} = 6.25V ± 0.25V; V_{PP} = 12.75V ± 0.25V)

Symbol	Parameter	Test Condition	Min	Max	Unit
I _{LI}	Input Leakage Current	0 ≤ V _{IN} ≤ V _{IH}		±10	μA
I _{CC}	Supply Current			50	mA
I _{PP}	Program Current	$\bar{E} = V_{IL}$		50	mA
V _{IL}	Input Low Voltage		-0.3	0.8	V
V _{IH}	Input High Voltage		2	V _{CC} + 0.5	V
V _{OL}	Output Low Voltage	I _{OL} = 2.1mA		0.4	V
V _{OH}	Output High Voltage TTL	I _{OH} = -400μA	2.4		V
V _{ID}	A9 Voltage		11.5	12.5	V

Note: 1. V_{CC} must be applied simultaneously with or before V_{PP} and removed simultaneously or after V_{PP}.

Table 10. Programming Mode AC Characteristics (1)
 (T_A = 25 °C; V_{CC} = 6.25V ± 0.25V; V_{PP} = 12.75V ± 0.25V)

Symbol	Alt	Parameter	Min	Max	Unit
t _{AVPL}	t _{AS}	Address Valid to Program Low	2		μs
t _{QVPL}	t _{DS}	Input Valid to Program Low	2		μs
t _{VPHPL}	t _{VPS}	V _{PP} High to Program Low	2		μs
t _{VCHPL}	t _{VCS}	V _{CC} High to Program Low	2		μs
t _{ELPL}	t _{CES}	Chip Enable Low to Program Low	2		μs
t _{PLPH}	t _{PW}	Program Pulse Width	95	105	μs
t _{PHQX}	t _{DH}	Program High to Input Transition	2		μs
t _{QXGL}	t _{OES}	Input Transition to Output Enable Low	2		μs
t _{GLQV}	t _{OE}	Output Enable Low to Output Valid		100	ns
t _{GHQZ} (2)	t _{DFP}	Output Enable High to Output Hi-Z	0	130	ns
t _{GHAX}	t _{AH}	Output Enable High to Address Transition	0		ns

Note: 1. V_{CC} must be applied simultaneously with or before V_{PP} and removed simultaneously or after V_{PP}.
 2. Sampled only, not 100% tested.

Programming

When delivered, all bits of the M27W202 are in the '1' state. Data is introduced by selectively programming '0's into the desired bit locations. Although only '0's will be programmed, both '1's and '0's can be present in the data word. The

M27W202 is in the programming mode when V_{PP} input is at 12.75V, \bar{E} is at V_{IL} and \bar{P} is pulsed to V_{IL}. The data to be programmed is applied to 16 bits in parallel, to the data output pins. The levels required for the address and data inputs are TTL. V_{CC} is specified to be 6.25V ± 0.25V.

Figure 6. Programming and Verify Modes AC Waveforms

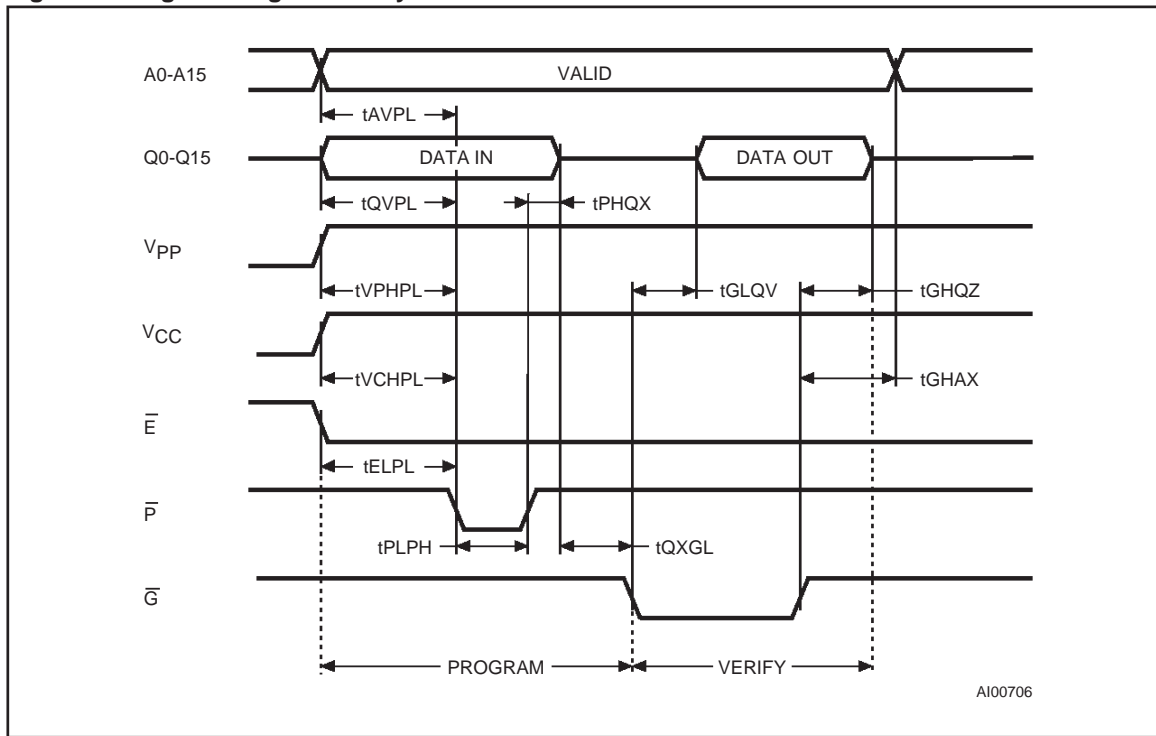
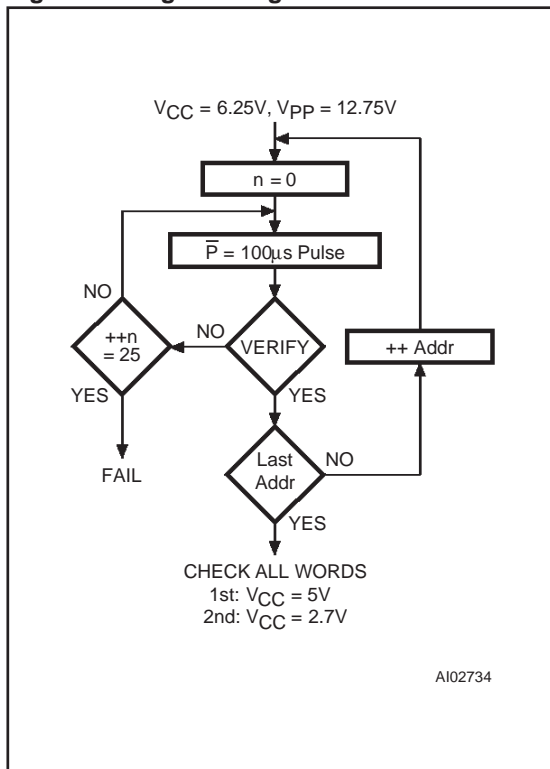

Figure 7. Programming Flowchart



PRESTO II Programming Algorithm

PRESTO II Programming Algorithm allows programming of the whole array with a guaranteed margin, in a typical time of 13 seconds. Programming with PRESTO II consists of applying a sequence of 100 µs program pulses to each word until a correct verify occurs (see Figure 7). During programming and verify operation, a MARGIN MODE circuit is automatically activated in order to guarantee that each cell is programmed with enough margin. No overprogram pulse is applied since the verify in MARGIN MODE at V_{CC} much higher than 3.6V, provides necessary margin to each programmed cell.

Program Inhibit

Programming of multiple M27W202s in parallel with different data is also easily accomplished. Except for \bar{E} , all like inputs including \bar{G} of the parallel M27W202 may be common. A TTL low level pulse applied to a M27W202's \bar{P} input, with \bar{E} low and V_{PP} at 12.75V, will program that M27W202. A high level \bar{E} input inhibits the other M27W202s from being programmed.

Program Verify

A verify (read) should be performed on the programmed bits to determine that they were correctly programmed. The verify is accomplished with \bar{E} and \bar{G} at V_{IL}, \bar{P} at V_{IH}, V_{PP} at 12.75V and V_{CC} at 6.25V.



On-Board Programming

The M27W202 can be directly programmed in the application circuit. See the relevant Application Note AN620.

Electronic Signature

The Electronic Signature (ES) mode allows the reading out of a binary code from an EPROM that will identify its manufacturer and type. This mode is intended for use by programming equipment to automatically match the device to be programmed with its corresponding programming algorithm. The ES mode is functional in the $25^{\circ}\text{C} \pm 5^{\circ}\text{C}$ ambient temperature range that is required when programming the M27W202. To activate the ES mode, the programming equipment must force 11.5V to 12.5V on address line A9 of the M27W202 with $V_{PP} = V_{CC} = 5\text{V}$. Two identifier bytes may then be sequenced from the device outputs by toggling address line A0 from V_{IL} to V_{IH} . All other address lines must be held at V_{IL} during Electronic Signature mode. Byte 0 ($A0 = V_{IL}$) represents the manufacturer code and byte 1 ($A0 = V_{IH}$) the device identifier code. For the STMicroelectronics M27W202, these two identifier bytes are given in Table 4 and can be read-out on outputs Q7 to Q0.

ERASURE OPERATION (applies to UV EPROM)

The erasure characteristics of the M27W201 are such that erasure begins when the cells are exposed to light with wavelengths shorter than approximately 4000 Å. It should be noted that sunlight and some type of fluorescent lamps have wavelengths in the 3000-4000 Å range. Data shows that constant exposure to room level fluorescent lighting could erase a typical M27W201 in about 3 years, while it would take approximately 1 week to cause erasure when exposed to direct sunlight. If the M27W201 is to be exposed to these types of lighting conditions for extended periods of time, it is suggested that opaque labels be put over the M27W201 window to prevent unintentional erasure. The recommended erasure procedure for the M27W201 is exposure to short wave ultraviolet light which has wavelength of 2537 Å. The integrated dose (i.e. UV intensity x exposure time) for erasure should be a minimum of 15 W-sec/cm². The erasure time with this dosage is approximately 15 to 20 minutes using an ultraviolet lamp with 12000 μW/cm² power rating. The M27W201 should be placed within 2.5 cm (1 inch) of the lamp tubes during the erasure. Some lamps have a filter on their tubes which should be removed before erasure.

M27W202

Table 11. Ordering Information Scheme

Example:	M27W202	-100	K	6	TR
Device Type M27					
Supply Voltage W = 2.7V to 3.6V					
Device Function 202 = 2 Mbit (128Kb x16)					
Speed -100 ^(1,2) = 100ns -120 = 120ns					
Not For New Design ⁽³⁾ -150 = 150 ns -200 = 200 ns					
Package F = FDIP40W ⁽⁴⁾ B = PDIP40 K = PLCC44 N = TSOP40: 10 x 14 mm ⁽⁴⁾					
Temperature Range 6 = -40 to 85 °C					
Options TR = Tape & Reel Packing					

- Note: 1. High Speed, see AC Characteristics section for further information.
 2. This speed also guarantees 80ns access time at V_{CC} = 3.0V to 3.6V.
 3. These speeds are replaced by the 120ns.
 4. Packages option available on request. Please contact STMicroelectronics local Sales Office.

For a list of available options (Speed, Package, etc...) or for further information on any aspect of this device, please contact the STMicroelectronics Sales Office nearest to you.

Table 12. Revision History

Date	Revision Details
November 1998	First Issue
04/19/00	From Product Preview to Data Sheet FDIP40W Package added Icc2 Standby current changed

Table 13. FDIP40W - 40 lead Ceramic Frit-seal DIP with window, Package Mechanical Data

Symbol	mm			inches		
	Typ	Min	Max	Typ	Min	Max
A			5.72			0.225
A1		0.51	1.40		0.020	0.055
A2		3.91	4.57		0.154	0.180
A3		3.89	4.50		0.153	0.177
B		0.41	0.56		0.016	0.022
B1	1.45	–	–	0.057	–	–
C		0.23	0.30		0.009	0.012
D		51.79	52.60		2.039	2.071
D2	48.26	–	–	1.900	–	–
E	15.24	–	–	0.600	–	–
E1		13.06	13.36		0.514	0.526
e	2.54	–	–	0.100	–	–
eA	14.99	–	–	0.590	–	–
eB		16.18	18.03		0.637	0.710
L		3.18	4.10		0.125	0.161
S		1.52	2.49		0.060	0.098
∅	8.13	–	–	0.320	–	–
α		4°	11°		4°	11°
N		40			40	

Figure 8. FDIP40W - 40 lead Ceramic Frit-seal DIP with window, Package Outline

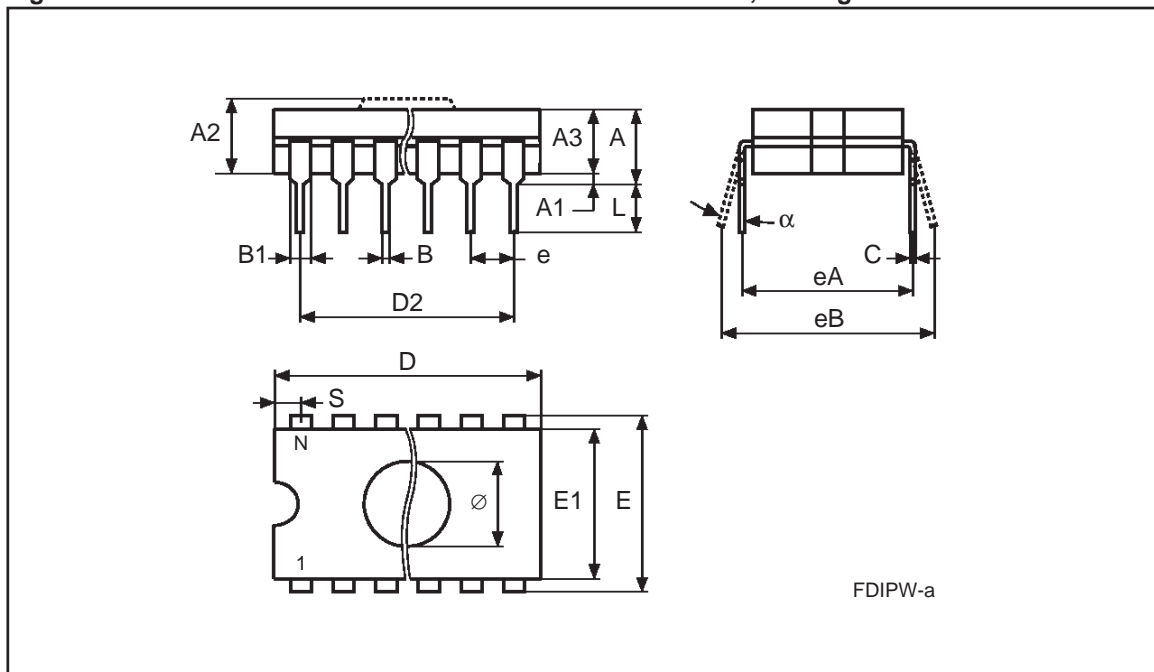

Drawing is not to scale.

M27W202

Table 14. PDIP40 - 40 pin Plastic DIP, 600 mils width, Package Mechanical Data

Symbol	mm			inches		
	Typ	Min	Max	Typ	Min	Max
A	4.45	–	–	0.175	–	–
A1	0.64	0.38	–	0.025	0.015	–
A2		3.56	3.91		0.140	0.154
B		0.38	0.53		0.015	0.021
B1		1.14	1.78		0.045	0.070
C		0.20	0.31		0.008	0.012
D		51.78	52.58		2.039	2.070
D2	48.26	–	–	1.900	–	–
E		14.80	16.26		0.583	0.640
E1		13.46	13.99		0.530	0.551
e1	2.54	–	–	0.100	–	–
eA	15.24	–	–	0.600	–	–
eB		15.24	17.78		0.600	0.700
L		3.05	3.81		0.120	0.150
S		1.52	2.29		0.060	0.090
α		0°	15°		0°	15°
N		40			40	

Figure 9. PDIP40 - 40 lead Plastic DIP, 600 mils width, Package Outline

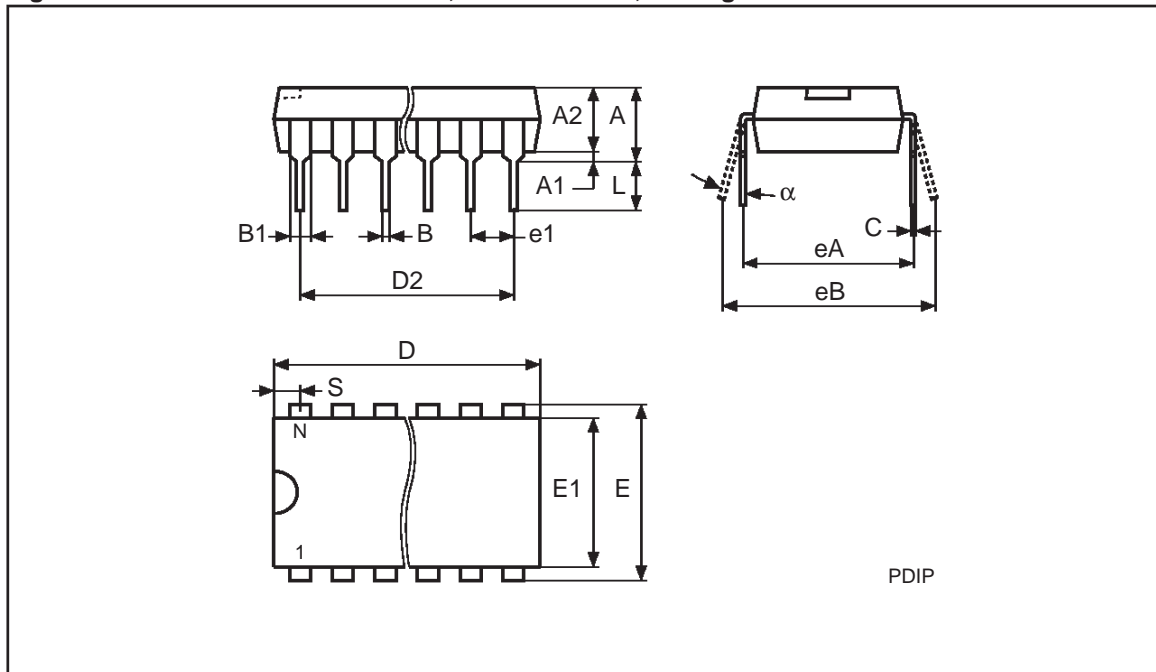

Drawing is not to scale.

Table 15. PLCC44 - 44 lead Plastic Leaded Chip Carrier, Package Mechanical Data

Symbol	mm			inches		
	Typ	Min	Max	Typ	Min	Max
A		4.20	4.70		0.165	0.185
A1		2.29	3.04		0.090	0.120
A2		–	0.51		–	0.020
B		0.33	0.53		0.013	0.021
B1		0.66	0.81		0.026	0.032
D		17.40	17.65		0.685	0.695
D1		16.51	16.66		0.650	0.656
D2		14.99	16.00		0.590	0.630
E		17.40	17.65		0.685	0.695
E1		16.51	16.66		0.650	0.656
E2		14.99	16.00		0.590	0.630
e	1.27	–	–	0.050	–	–
F		0.00	0.25		0.000	0.010
R	0.89	–	–	0.035	–	–
N		44			44	
CP			0.10			0.004

Figure 10. PLCC44 - 44 lead Plastic Leaded Chip Carrier, Package Outline

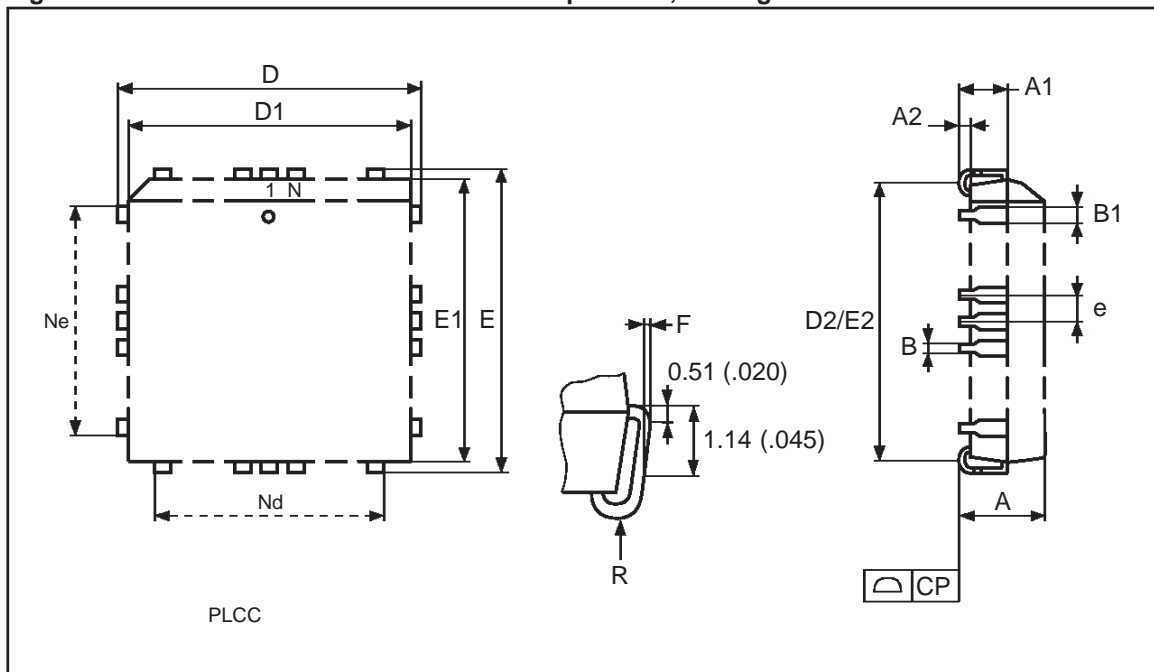

Drawing is not to scale.

Table 16. TSOP40 - 40 lead Plastic Thin Small Outline, 10 x 14 mm, Package Mechanical Data

Symbol	mm			inches		
	Typ	Min	Max	Typ	Min	Max
A			1.20			0.0472
A1		0.05	0.15		0.0020	0.0059
A2		0.95	1.05		0.0374	0.0413
B		0.17	0.27		0.0067	0.0106
C		0.10	0.21		0.0039	0.0083
D		13.80	14.20		0.5433	0.5591
D1		12.30	12.50		0.4843	0.4921
E		9.90	10.10		0.3898	0.3976
e	0.50	-	-	0.0197	-	-
L		0.50	0.70		0.0197	0.0276
α		0°	5°		0°	5°
N		40			40	
CP			0.10			0.0039

Figure 11. TSOP40 - 40 lead Plastic Thin Small Outline, 10 x 14 mm, Package Outline

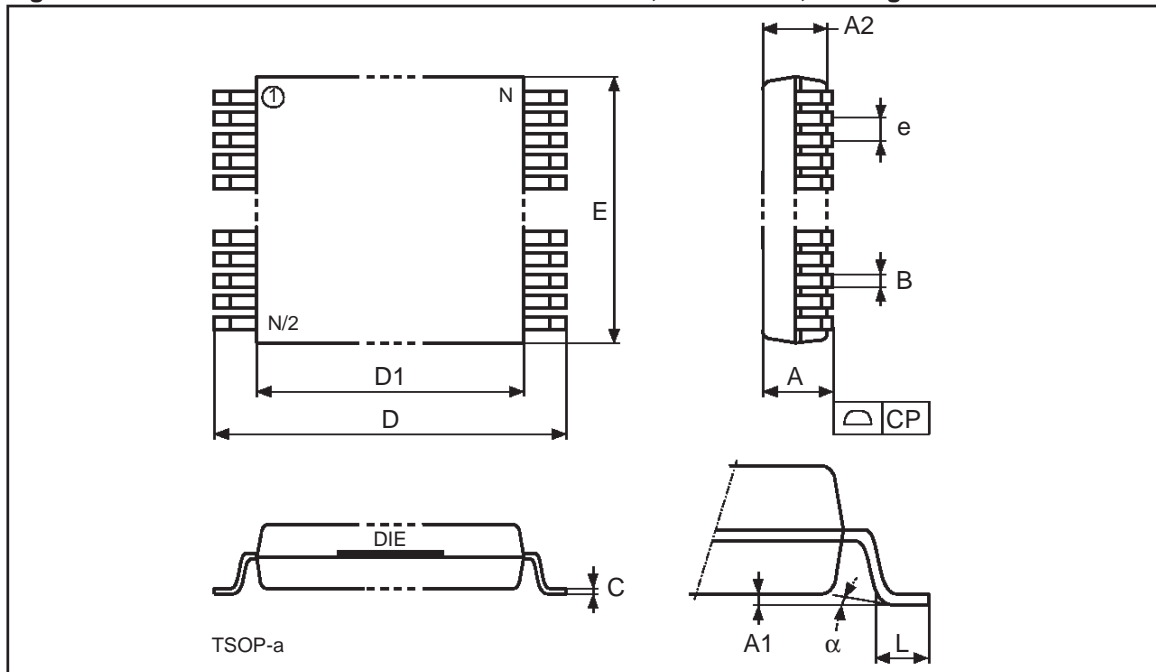

Drawing is not to scale.

Information furnished is believed to be accurate and reliable. However, STMicroelectronics assumes no responsibility for the consequences of use of such information nor for any infringement of patents or other rights of third parties which may result from its use. No license is granted by implication or otherwise under any patent or patent rights of STMicroelectronics. Specifications mentioned in this publication are subject to change without notice. This publication supersedes and replaces all information previously supplied. STMicroelectronics products are not authorized for use as critical components in life support devices or systems without express written approval of STMicroelectronics.

The ST logo is registered trademark of STMicroelectronics
® 2000 STMicroelectronics - All Rights Reserved

All other names are the property of their respective owners.

STMicroelectronics GROUP OF COMPANIES
Australia - Brazil - China - Finland - France - Germany - Hong Kong - India - Italy - Japan - Malaysia - Malta - Morocco -
Singapore - Spain - Sweden - Switzerland - United Kingdom - U.S.A.

<http://www.st.com>

