



AMC7580

7A LOW DROPOUT REGULATOR

DESCRIPTION	FEATURES
<p>The AMC7580 is a high performance low dropout regulator rated for 7A output current with fixed 2.5V/3.3V/5.0V and adjustable output. It is designed for use in applications requiring low dropout characteristics over the rated current range.</p> <p>When the second low-current input voltage is applied, the drop out voltage can be as low as 100mV at light loads and up to 500mV at maximum output current. On chip trimming adjusts the reference voltage to 1%. These features are ideal for low voltage microprocessor applications requiring a regulated 2.5V to 3.6V power supply.</p> <p>In addition, the AMC7580 provides the device protections including over current and thermal shutdown. The AMC7580 series are ideal to the next generation microprocessor on motherboards where both 5V and 3.3V are available.</p>	<ul style="list-style-type: none"> ■ Input-Output differential of typical 500mV at 7A and low quiescent current ■ Output current is excess of 7A □ Remote sense pin available □ Reverse battery protection □ Short circuit protection □ Internal thermal overload protection □ Available in 5L plastic TO-220 and surface mount 5L TO-263 packages □ Pin assignment identical to EZ1585 series.

APPLICATIONS	PACKAGE PIN OUT
--------------	-----------------

- Pentium® Processor Supplies
- PowerPC™ Supplies
- Computer Add-On Cards
- Other Applications Requiring Low Dropout Voltage Over Rated Current.

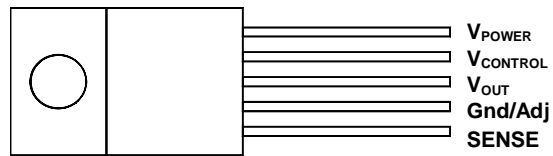

5-Pin Plastic TO-220
(Top View)

- AMC7580-2.5 – 2.5V Fixed
- AMC7580-3.3 – 3.3V Fixed
- AMC7580-5.0 – 5.0V Fixed
- AMC7580-ADJ – Adjustable

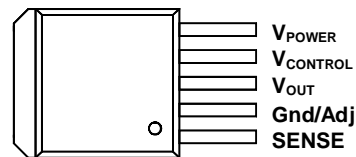

5-Pin Plastic TO-263
Surface Mount
(Top View)

ORDER INFORMATION				
T _A (°C)	P	Plastic TO-220	DD	Plastic TO-263
		5-pin		5-pin
0 to 70		AMC7580-X.XP		AMC7580-X.XDD
0 to 70		AMC7580-X.XPF (Lead Free)		AMC7580-X.XDDF (Lead Free)
0 to 70		AMC7580-ADJP		AMC7580-ADJDD
0 to 70		AMC7580-ADJPF (Lead Free)		AMC7580-ADJDDF (Lead Free)

Note: 1. All surface-mount packages are available in Tape & Reel. Append the letter "T" to part number (i.e., AMC7580-X.XDDT).
2. The letter "F" is marked for Lead Free process.

TYPICAL APPLICATION

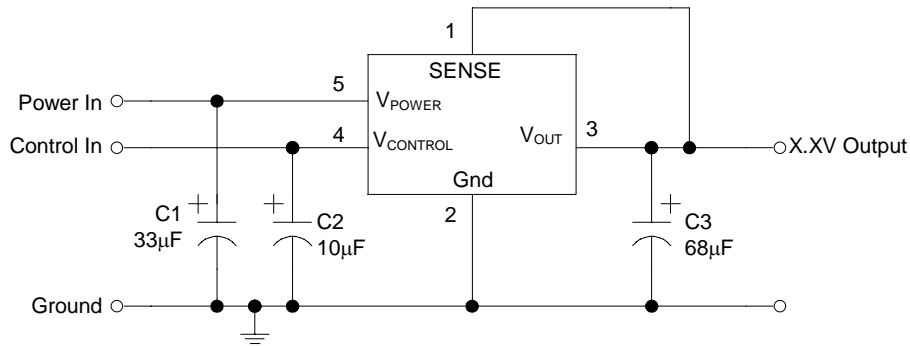

AMC7580-X.X application schematic

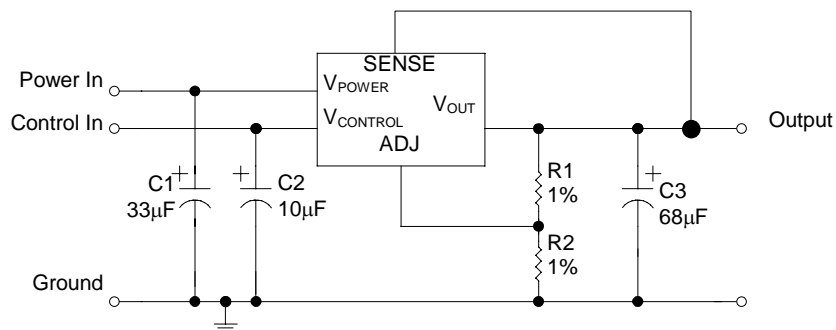

$$V_{OUT} = V_{REF} (1 + (R2/R1)) + I_{ADJ}R2$$

AMC7580-ADJ application schematic

ABSOLUTE MAXIMUM RATINGS (Note 1)	
Input Voltage (V _{power})	7V
Input Voltage (V _{control})	13V
Operating Junction temperature	150°C
Storage Temperature Range	-65°C to 150°C
Lead temperature (Soldering, 10 seconds)	300°C

Note 1: Exceeding these ratings could cause damage to the device. All voltages are with respect to Ground. Currents are positive into, negative out of the specified terminal.

POWER DISSIPATION TABLE					
Package	θ_{JA} (°C/W)	Derating factor (mW/°C) $T_A \geq 25^\circ\text{C}$	$T_A \leq 25^\circ\text{C}$	$T_A = 70^\circ\text{C}$	$T_A = 85^\circ\text{C}$
			Power rating(mW)	Power rating(mW)	Power rating (mW)
P	45	22.2	2775	1776	1443
PF	45	22.2	2775	1776	1443
DD	45	22.2	2775	1776	1443
DDF	45	22.2	2775	1776	1443

Note :

- θ_{JA} : Thermal Resistance-Junction to Ambient, D_F : Derating factor, P_o : Power consumption.
Junction Temperature Calculation: $T_J = T_A + (P_D \times \theta_{JA})$, $P_o = D_F \times (T_J - T_A)$
The θ_{JA} numbers are guidelines for the thermal performance of the device/PC-board system.
All of the above assume no ambient airflow.
- θ_{JT} : Thermal Resistance-Junction to Tab, T_C : case(Tab) temperature, $T_J = T_C + (P_D \times \theta_{JT})$
For P and DD packages, $\theta_{JT} = 3.0^\circ\text{C} / \text{W}$.
- If power consumption is over above rating, adequate heat sink is required to dissipate heat.

RECOMMENDED OPERATING CONDITIONS					
Parameter	Symbol	Recommended Operating Conditions			Units
		Min.	Typ.	Max.	
Input Voltage (V _{IN})	V _{POWER}	2		7	V
	V _{CONTROL}	2.75		12	
Load Current (with adequate heatsinking)	I _O	0.010		7	A
Input Capacitor (V _{IN} to GND)		10			μF
Output Capacitor with ESR of 10Ω max., (V _{OUT} to GND)		33			μF

BLOCK DIAGRAM

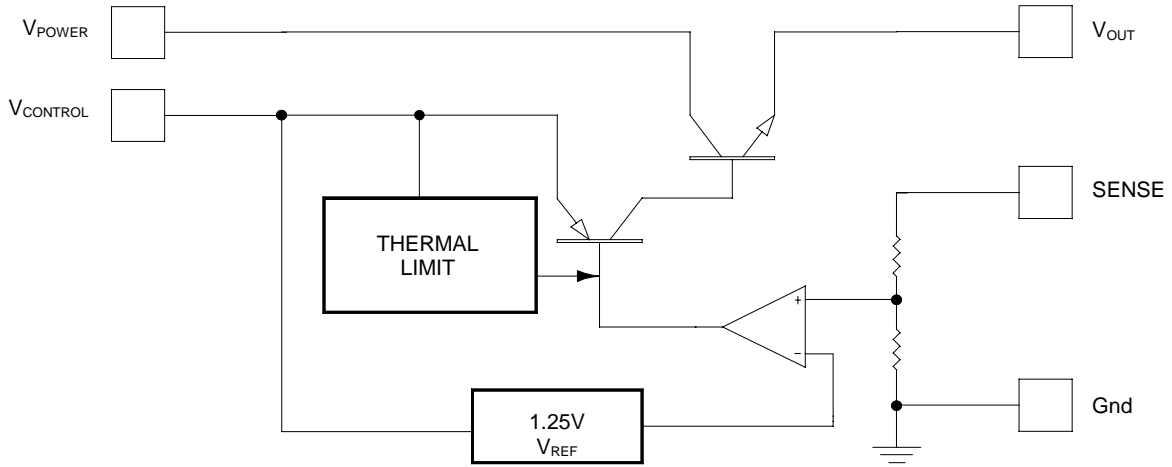

AMC7580-X.X circuit schematic

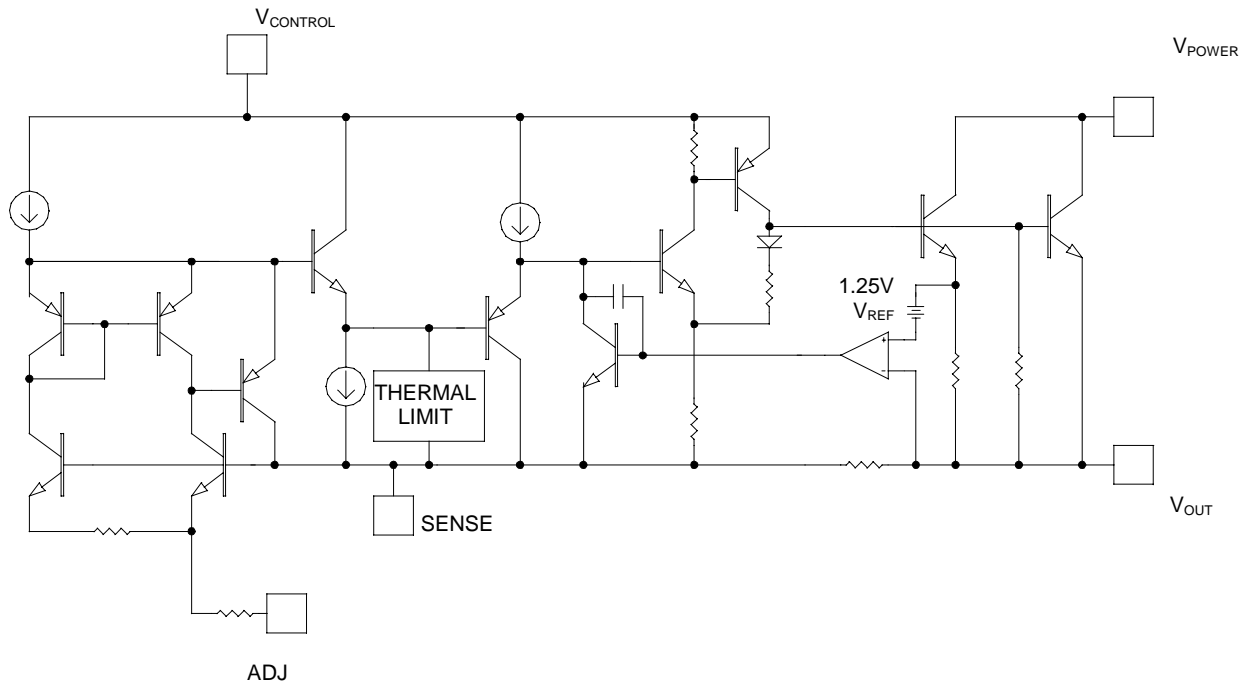

AMC7580-ADJ circuit schematic

ELECTRICAL CHARACTERISTICS											
Unless otherwise specified, these specifications apply $T_J = 25^\circ\text{C}$ for AMC7580; $I_O = 10\text{mA}$, $V_{OUT} = V_{SENSE}$, and are for DC characteristics only. (Low duty cycle pulse testing techniques are used which maintains junction and case temperatures equal to the ambient temperature.)											
Parameter	Symbol	Test Conditions	AMC7580			Units					
			Min.	Typ.	Max.						
Output Voltage	AMC7580-2.5	V_{OUT}	$V_{CONTROL} = 5.0\text{V}$, $V_{POWER} = 3.3\text{V}$		2.474	2.500	2.525	V			
	AMC7580-3.3		$V_{CONTROL} = 5.8\text{V}$, $V_{POWER} = 3.8\text{V}$		3.267	3.300	3.333				
	AMC7580-5.0		$V_{CONTROL} = 7.5\text{V}$, $V_{POWER} = 5.5\text{V}$		4.950	5.000	5.050				
Output Voltage	AMC7580-2.5	V_{OUT}	$V_{CONTROL} = 5.0\text{V}$, $V_{POWER} = 3.3\text{V}$		2.460	2.500	2.540	V			
	AMC7580-3.3		$V_{CONTROL} = 5.0\text{V}$, $V_{POWER} = 4.1\text{V}$						3.247	3.300	3.353
	AMC7580-5.0		$V_{CONTROL} = 6.5\text{V}$, $V_{POWER} = 5.8\text{V}$						4.920	5.000	5.080
Reference Voltage	AMC7580-ADJ	V_{REF}	$V_{CONTROL} = 5.0\text{V}$, $V_{POWER} = 3.3\text{V}$, (Note 1)		1.238	1.250	1.262	V			
			$V_{CONTROL} = (V_{OUT} + 1.5\text{V})$ to 12V , $V_{POWER} = (V_{OUT} + 0.8\text{V})$ to 7V , $I_O = 10\text{mA}$ to 7A		1.230	1.250	1.270				
Line Regulation (Note 2)	ΔV_{OI}	$(1.5\text{V} + V_{OUT}) \leq V_{CONTROL} \leq 12\text{V}$, $0.8\text{V} \leq (V_{POWER} - V_{OUT}) \leq 5.5\text{V}$			0.04	0.2	%				
Load regulation (Note 2)	ΔV_{OL}	$V_{CONTROL} = V_{OUT} + 2.5\text{V}$, $V_{POWER} = V_{OUT} + 0.8\text{V}$, $I_O = 10\text{mA}$ to 7A			0.08	0.3	%				
Dropout Voltage $V_{CONTROL} - V_{OUT}$ (Note 3)	ΔV	$V_{POWER} = V_{OUT} + 0.8\text{V}$	$I_O = 10\text{mA}$		1.00	1.15	V				
			$I_O = 7\text{A}$		1.15	1.30					
Dropout Voltage $V_{POWER} - V_{OUT}$ (Note 3)	ΔV	$V_{CONTROL} = V_{OUT} + 2.5\text{V}$	$I_O = 10\text{mA}$		0.10	0.17	V				
			$I_O = 7\text{A}$		0.45	0.50					
Adjust Pin Current	I_{ADJ}	$V_{CONTROL} = 2.75\text{V}$, $V_{POWER} = 2.05\text{V}$, $I_O = 10\text{mA}$			50	120	μA				
Control Pin Current	I_{CTNL}	$V_{CONTROL} = V_{OUT} + 2.5\text{V}$, $V_{POWER} = V_{OUT} + 0.8\text{V}$, $I_O = 10\text{mA}$ to 7A			80	135	mA				
Current Limit	I_{CL}	$(V_{IN} - V_{OUT}) = 1.5\text{V}$		7	8		A				
Minimum Load Current (Note 4)	I_{min}	$V_{CONTROL} = 5.0\text{V}$, $V_{POWER} = 3.3\text{V}$			5	10	mA				
Ripple Rejection (Note 5)	R_R	$V_{CONTROL} = V_{POWER} = V_{OUT} + 2.5\text{V}$, $V_{RIPPLE} = 1V_{PP}$, $I_O = 2.5\text{A}$		60	80		dB				
Thermal Regulation		$T_A = 25^\circ\text{C}$			0.003		% / W				

Note 1 Output voltage is set to be 2.5V.

Note 2: Line and load regulations are guaranteed up to maximum power dissipation determined by input/output differential and the output current. However, the maximum power will not be available over the full input/output voltage range.

Note 3: The dropout voltage is measured by either minimum control voltage or power voltage. The specifications represent the minimum input/output voltage required to maintain 1% regulation.

Note 4: The minimum load current is the minimum current required to maintain regulation. Normally the current in the resistor divider used to set the output voltage is selected to meet the minimum load current requirement.

Note 5: These parameters, although guaranteed, are not tested in production prior to shipment

APPLICATION INFORMATION

• General

The AMC7580 series is designed to power the new generation of microprocessors. It is designed to make use of multiple power supplies, present in most systems, to reduce the dropout voltage. One of the advantages of the two-supply approach is maximizing the efficiency.

The second supply is at least 1V greater than output voltage and is providing the power for the control circuitry and supplies the drive current to the NPN output transistor. This allows the NPN output transistor to be driven into saturation. For the control voltage the current requirement is small, about 1% of the output current or approximately 50 mA for a 7A load. This drive current becomes part of the output current. The maximum voltage on the Control pin is 13 V. The maximum voltage at the Power pin is 7 V. By trying the control and power inputs together the AMC7580 can also be operated as a single supply device. In single supply operation, the dropout voltage will be determined by the minimum the Control voltage.

The new generation of microprocessors cycle load current from several hundred milliamperes to several amperes in tens of nanoseconds. Output voltage tolerances are tighter and include transient response as part of the specification. Designed to meet the fast current load step requirements of these microprocessors, the AMC7580-X.X also saves total cost by needing less output capacitance to maintain regulation.

The sense pin permits very accurate regulation of output voltage. As a result, over an output current range of 100mA to 7A, the typical load regulation is less than 1mV.

In addition to the enhancements mentioned, the reference accuracy has been improved a factor of two with a guaranteed initial tolerance of $\pm 1\%$ at 25°C and 1.6% accuracy over the full temperature and load current range.

Typical applications for the AMC7580 include 3.3V to 2.5 V conversion with a 5V control supply, 5V to 4.2V conversion with a 12V control supply or 5V to 3.6V conversion with a 12V control supply. It is easy to obtain dropout voltages of less than 0.5V at 2.5A along with excellent static and dynamic specifications. The device is fully protected against over current and over temperature conditions.

• Grounding and Output Sensing

The AMC7580-ADJ allows true Kelvin sensing for both the high and low side of the load. As a result the voltage regulation at the load can be easily optimized. Voltage drops due to parasitic resistances between the regulator and the load can be placed inside the regulation loop. The advantages of remote sensing are illustrated in figures 1 through 3.

Figure 1 shows the device connected as a conventional 3 terminal regulator with the Sense lead connected directly to the output of the device. R_p is the parasitic resistance of the connections between the device and the load. Trace A of figure 3 illustrates the effect of R_p .

Figure 2 shows the device connected to take advantage of the remote sense feature. The Sense pin and the top of the resistor divider are connected to the top of the load; the bottom of the resistor divider is connected to the bottom of the load. The effect on output regulation can be seen in trace B of figure 3.

It is important to note that the voltage drops due to R_p are not eliminated; they will add to the dropout voltage of the regulator regardless. The AMC7580-ADJ can control the voltage at the load as long as the input-output voltage is greater than the total of the dropout voltage of the device plus the voltage drop across R_p .

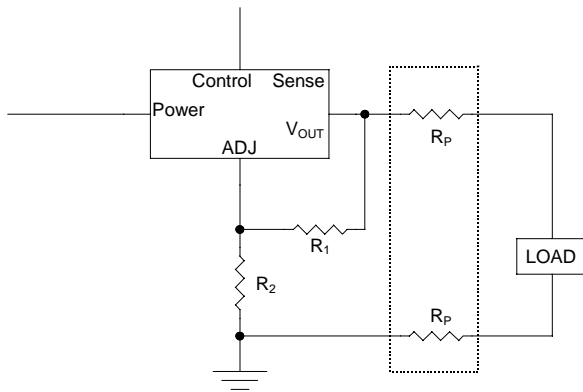

Figure 1. Conventional Load Sensing

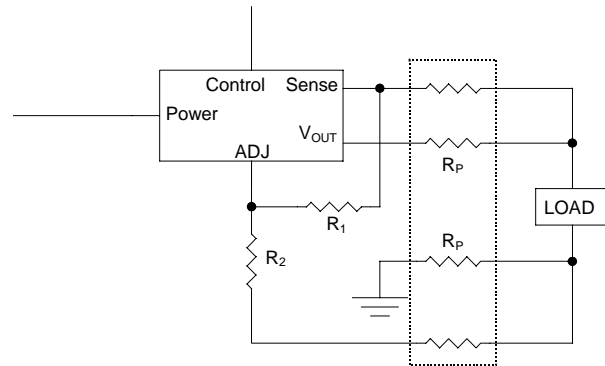

Figure 2. Remote Load Sensing

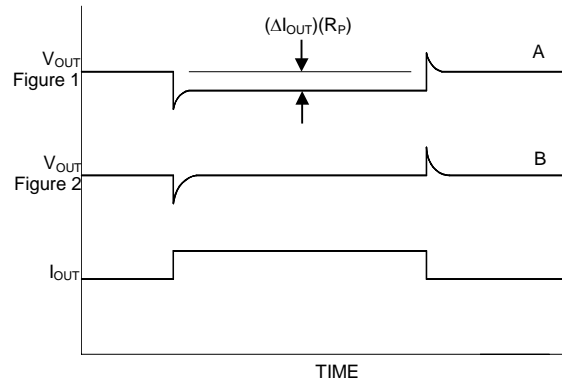

Figure 3. Remote Sensing Improves Load Regulation

• **Stability**

The Circuit design used in the AMC7580 series requires the use of an output capacitor as part of the device frequency compensation. The addition of 150μF Aluminum electrolytic or a 22μF solid tantalum on the output will ensure stability for all operating conditions. In order to meet the transient performance of the processor larger value capacitors are needed. To limit the high frequency noise generated by the processor, high quality bypass capacitors must be used. In order to limit parasitic inductance (ESL) and resistance (ESR) in capacitors to acceptable limits, multiple small ceramic capacitor in addition to high quality solid tantalum capacitors are required.

When the adjustment terminal is bypassed to improve the ripple rejection, the requirement for an output capacitor increases. To further improve stability and transient response of these devices larger values of output capacitor can be used. The modern processors generate large high frequency current transients.

The load current step contains higher order frequency components than the output coupling network must handle until the regulator throttles to the load current level. Because they contain parasitic resistance and inductance, capacitors are not ideal elements. These parasitic elements dominate the change in output voltage at the beginning of a transient load step change. The ESR of the output capacitors produces an instantaneous step in output voltage at the beginning of a transient load step change. The ESR of the output capacitors produces an instantaneous step in out voltage $\Delta V = \Delta I(ESR)$. The ESL of the output capacitors produces a droop proportional to the rate of change of the output current $\Delta V = L(\Delta I/\Delta t)$. The output capacitance produces a change in output voltage proportional to the time until the regulator can respond $\Delta V = \Delta t(\Delta I/C)$. Figure 4 illustrates these transient effects.

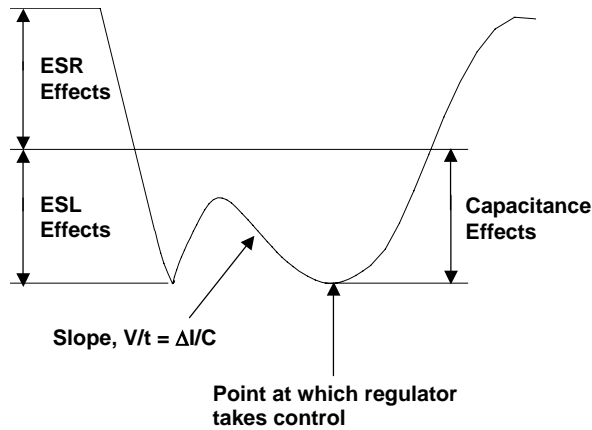

Figure 4.

• **Output Voltage**

The AMC7580-ADJ develops a 1.25V reference voltage between the Sense pin and the Adjust pin (Figure 5). Placing a resistor between these two terminals causes a constant current to flow through R1 and down through R2 to set the output voltage. In general R1 is chosen so that this current is the specified minimum load current of 10 mA. The current out of the Adjust pin is small, typically 50μA and it adds to the current for R1. For best regulation the top of the resistor divider should be connected directly to the Sense pin.

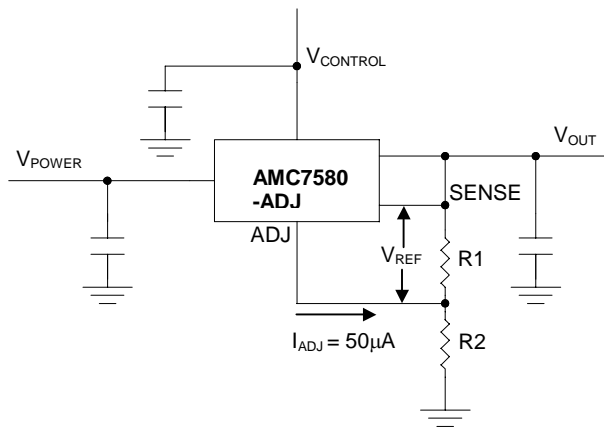

Figure 5 Setting Output Voltage

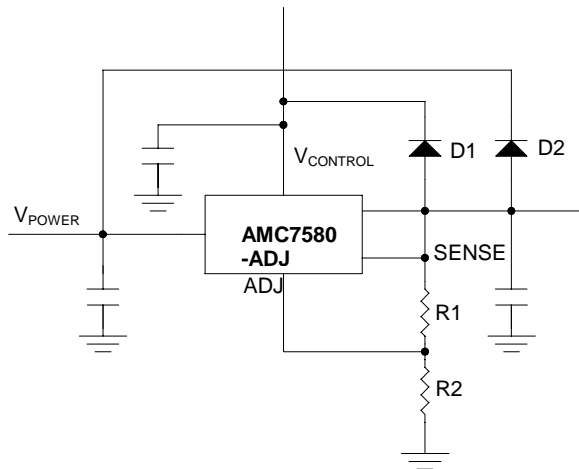

Figure 6. Optional Clamp Diodes Protect Against Input Crowbar Circuit

• Protection Diodes

In normal operation, AMC7580 family does not need any protection diodes between the adjustment pin and the output and from the output to the input to prevent die overstress. Internal resistors are limiting the internal current paths on the ADJ pin. Therefore even with bypass capacitors on the adjust pin no protection diode is needed to ensure device safety under short-circuit conditions. The Adjust pin can be driven on a transient basis $\pm 7V$ with respect to the output without any device degradation.

A protection diode between the Output pin and V_{POWER} pin is not usually needed. Microsecond surge currents of 50A to 100A can be handled by the internal diode between the Output pin and V_{POWER} pin of the device. In normal operations it is difficult to get those values of surge currents even with the use of large output capacitances. Only with high value output capacitors, such as 1000 μF to 5000 μF and the V_{POWER} pin is instantaneously shorted to ground, damage can occur. A diode from output to input is recommended (Figure 6). If AMC7581 is connected as single supply device with the control and power input pins shorted together the internal diode between the output and power input pin will protect the control input pin.

• Thermal Consideration

The AMC7580-ADJ series has internal power and thermal limiting circuitry designed to protect the device under overload conditions. However maximum junction temperature ratings should not be exceeded under continuous normal load conditions. Careful consideration must be given to all sources of thermal resistance from junction to ambient, including junction-to-case, case-to-heat sink interface and heat sink resistance itself.

Junction temperature of the Control section can run up to 125 $^{\circ}C$. Junction temperature of the Power section can run up to 150 $^{\circ}C$. Due to the thermal gradients between the power transistor and the control circuitry there is a significant difference in thermal resistance between the Control and Power sections.

Virtually all the power dissipated by the device is dissipated in the power transistor. The temperature rise in the power transistor will be greater than the temperature rise in the Control section making the thermal resistance lower in the Control section. At power levels below 12W, the temperature gradient will be less than 25 $^{\circ}C$ and the maximum ambient temperature will be determined by the junction temperature of the Control section. This is due to the lower maximum junction temperature in the Control section. At power levels above 12W, the temperature gradient will be greater than 25 $^{\circ}C$ and the maximum ambient temperature will be determined by the Power section. In both cases the junction temperature is determined by the total power dissipated in the device. For most low dropout applications the power dissipation will be less than 12W.

The power in the device is made up of two components: the power in the output transistor and the power in the control circuit.

The power in the control circuit is negligible, which is equal to: $P_{CONTROL} = (V_{CONTROL} - V_{OUT}) / I_{CONTROL}$,

where $I_{CONTROL}$ is equal $I_{OUT} / 100$ (typ)

The power in the output transistor is equal to: $P_{OUTPUT} = (V_{POWER} - V_{OUT}) / I_{OUT}$

The total power is equal to: $P_{CONTROL} + P_{OUTPUT}$

Junction-to-case thermal resistance is specified from the IC junction to the bottom of the case directly below the die. This is the lowest resistance path for the heat flow. In order to ensure the best possible thermal flow this area of the package to the heat sink proper mounting is required. Thermal compound at the case-to-heat sink interface is recommended. A thermally conductive spacer can be used, if the case of the device must be electrically isolated, but its added contribution to thermal resistance has to be considered.

Maximum Power Calculation:

$$P_{D(MAX)} = \frac{T_{J(MAX)} - T_{A(MAX)}}{\theta_{JA}}$$

$T_J(^{\circ}C)$: Maximum recommended junction temperature

$T_A(^{\circ}C)$: Ambient temperature of the application

$\theta_{JA}(^{\circ}C/W)$: Junction-to-junction temperature thermal resistance of the package, and other heat dissipating materials.

The maximum power dissipation of a single-output regulator :

$$P_{D(MAX)} = [(V_{IN(MAX)} - V_{OUT(NOM)}) \times I_{OUT(NOM)} + V_{IN(MAX)} \times I_Q]$$

Where: $V_{OUT(NOM)}$ = the nominal output voltage

$I_{OUT(NOM)}$ = the nominal output current, and

I_Q = the quiescent current the regulator consumes at $I_{OUT(MAX)}$

$V_{IN(MAX)}$ = the maximum input voltage

Then $\theta_{JA} = (150^{\circ}C - T_A) / P_D$

Thermal consideration:

When power consumption is over about 1.2W(at 70°C ambient temperature), additional heat sink is required to control the junction temperature below 125°C.

The junction temperature is: $T_j = P_D (\theta_{JT} + \theta_{CS} + \theta_{SA}) + T_A$

P_D :Dissipated power.

θ_{JT} :Thermal resistance from the junction to the mounting tab of the package.

θ_{CS} : Thermal resistance through the interface between the IC and the surface on which it is mounted. (typically, $\theta_{CS} < 1.0^{\circ}C / W$)

θ_{SA} :Thermal resistance from the mounting surface to ambient (thermal resistance of the heat sink).

If PC Board copper is going to be used as a heat sink, below table can be used to determine the appropriate size of copper foil required. For multi-layered PCB, these layers can also be used as a heat sink. They can be connected with several through hole vias.

PCB $\theta_{SA} (^{\circ}C / W)$	59	45	38	33	27	24	21
PCB heat sink size (mm ²)	500	1000	1500	2000	3000	4000	5000

Recommended figure of PCB area used as a heat sink.

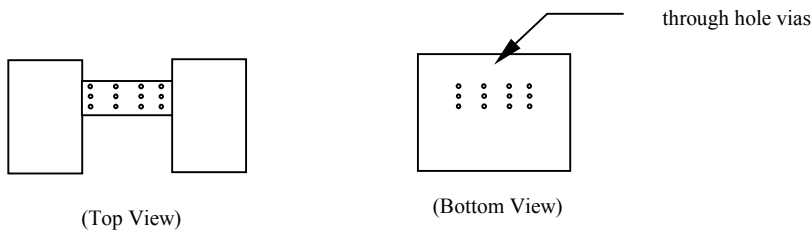

5-Pin Plastic TO-220

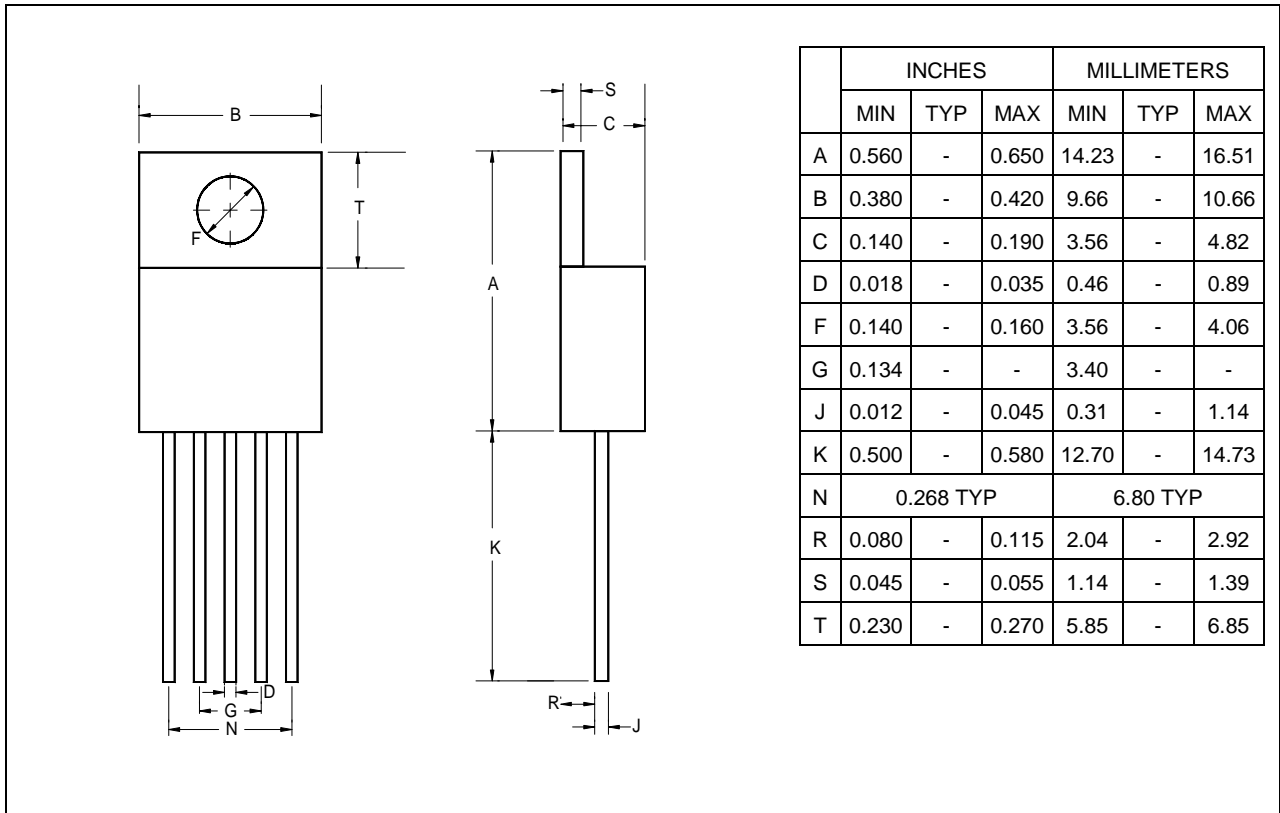

5-Pin Plastic TO-263

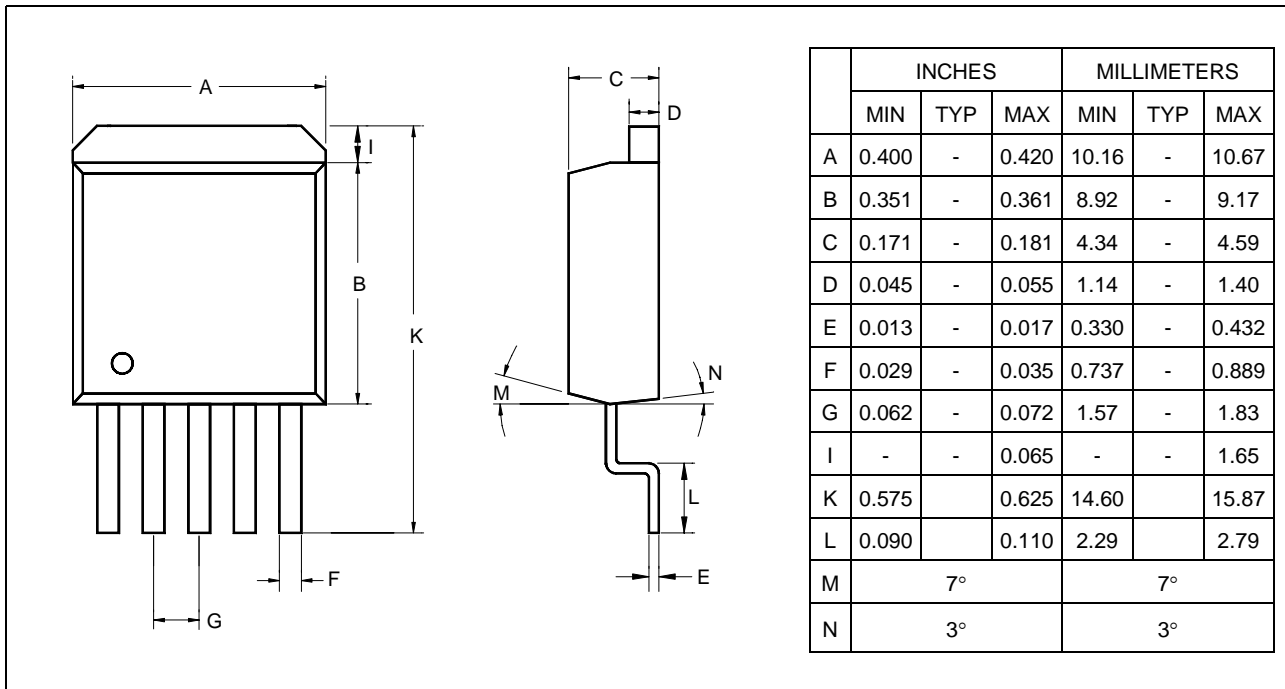

IMPORTANT NOTICE

ADD Microtech (ADDM) reserves the right to make changes to its products or to discontinue any integrated circuit product or service without notice, and advises its customers to obtain the latest version of relevant information to verify, before placing orders, that the information being relied on is current.

A few applications using integrated circuit products may involve potential risks of death, personal injury, or severe property or environmental damage. ADDM integrated circuit products are not designed, intended, authorized, or warranted to be suitable for use in life-support applications, devices or systems or other critical applications. Use of ADDM products in such applications is understood to be fully at the risk of the customer. In order to minimize risks associated with the customer's applications, the customer should provide adequate design and operating safeguards.

ADDM assumes no liability to customer product design or application support. ADDM warrants the performance of its products to the specifications applicable at the time of sale.

U.S.**ADD Microtech Inc.**

492 Altamont Drive
Milpitas, CA 95035

TEL: (408) 9410420

FAX: (408) 9410864

Asia Pacific region**ADD Microtech Corp**

13F, NO. 287, Sec. 3, Nan Jing E. Rd.,
Taipei, Taiwan 105

TEL: 2-27132800

FAX: 2-27132805