

- Limit sensing of almost any fluid or powder
- Two-tier level sensor - Hi / Low limits with one probe
- Only one external part required - a 5¢ capacitor
- Uses internal probes or external electrodes
- Active high or active low outputs
- Slosh filter averages response of moving fluids
- LED drive capable on both outputs
- 2.5 to 5V 20µA single supply operation
- HeartBeat™ health indicator on both outputs
- RoHS compliant package

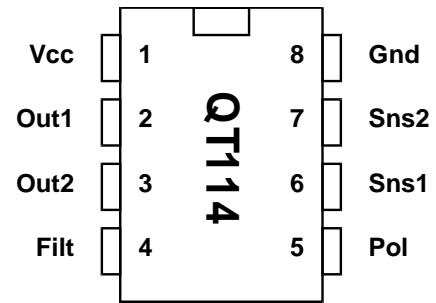

APPLICATIONS -

- ◆ Process controls**
- ◆ Consumer appliances**
- ◆ Medical fluid sensing**
- ◆ Vending machines**
- ◆ Automotive fluids**
- ◆ Soil moisture sensing**

DESCRIPTION -

The QT114 QLevel™ charge-transfer (“QT”) sensor IC is specifically designed to detect point level in fluids and powders. It will project a sense field through almost any dielectric, like glass, plastic, or ceramic, to sense level on the inside of a vessel, from its exterior. It has the unique capability of independently sensing two trip points when used with structured electrodes having two tiers.

The QT114 does not have sensing timeouts, drift compensation, or other functions which would interfere with level sensing. Its threshold levels are fixed, and the amount of signal required to exceed a threshold is dependent on circuit gain and electrode size and loading, all of which are under the control of the designer.

The QT114 requires only a single inexpensive capacitor in order to function. One or two LEDs can also be added to provide a visual sensing indication.

Power consumption is under 20mA in most applications, allowing operation from Lithium cells for many years. In most cases the power supply needs only minimal regulation.

The QT114 employs numerous signal acquisition and processing techniques pioneered by Quantum. No external switches, opamps, or other analog components aside from CS are required.

A unique feature is the 'slosh filter', a detection integrator which averages detections over a rolling 15 second interval before activating or deactivating the OUT pins. This filter allows use of the QT114 with violently moving fluids, for example in a moving vehicle, that would otherwise cause the outputs to flicker between two states.

The device also includes selectable output polarity, allowing both output lines to be made either active-high or active-low. It also includes the Quantum-pioneered HeartBeat™ signal, allowing a host controller to monitor the health of the QT114 continuously if desired. By using the charge transfer principle, the IC delivers a level of performance clearly superior to older technologies. It is specifically designed to replace electromechanical devices like float switches, thermistors, and conductance probes.

AVAILABLE OPTIONS

T _A	SOIC	8-PIN DIP
0°C to +70°C	-	QT114-DG
-40°C to +85°C	QT114-ISG	-

The QT114 is a digital burst mode charge-transfer (QT) sensor designed specifically for point level sensing; it includes all hardware and signal processing functions necessary to provide stable level sensing under a wide variety of changing conditions. Only a single external capacitor is required for operation.

Figure 1-1 shows a basic QT114 circuit using the device, with conventional OUT drives and power supply connections. The sensing electrode can be connected to a single-tier or 2-tier electrode as required.

Calibration is done by design, through adjustment of the electrode sizes and the C_s capacitor. Only under rare situations do QT114 circuits require calibration on an individual basis, and the circuit can make provision for that.

1 SIGNAL ACQUISITION

The QT114 employs a short, low duty cycle burst of charge-transfer cycles to acquire its signal. Burst mode permits power consumption in the low microamp range, dramatically reduces RF emissions, lowers susceptibility to EMI, and yet permits excellent response time. Internally the signals are digitally processed to generate the required output signals.

The QT switches and charge measurement hardware functions are all internal to the QT114 (Figure 1-2). A 14-bit single-slope switched capacitor ADC includes both the required QT charge and transfer switches in a configuration that provides direct ADC conversion. The burst length is inversely proportional to the rate of charge buildup on C_s , which in turn depends on the values of C_s , C_x , and V_{cc} . V_{cc} is used as the charge reference voltage. Larger values of C_x cause the charge transferred into C_s to accumulate more rapidly. The trip points of the sensor can be changed by altering C_s and C_x , the load capacitance. As a result, the values of C_s , C_x , and V_{cc} should be fairly stable over the expected operating temperature range.

Two fixed thresholds are used, one for low fluid level and the other for high level; adjusting C_s and C_x to allow these to trip at appropriate points is required by design, and if required may be trimmed by an adjustment. Figure 1-1 shows the optional potentiometer which can be used to fine-tune the placement of these threshold points relative to the signal.

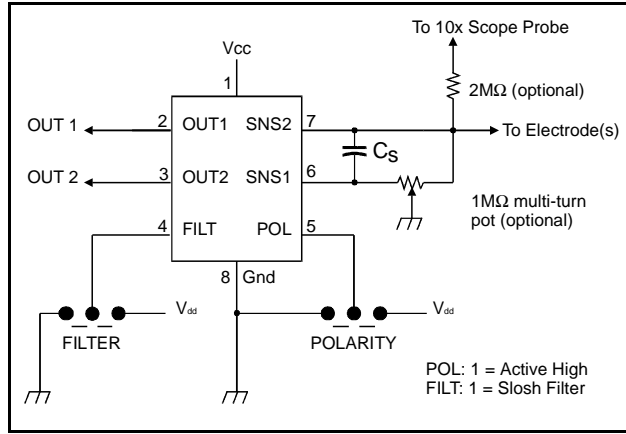

Figure 1-1 Standard mode options

It is not necessary to use both detection threshold points; if only single point sensing is desired, only the lower threshold and OUT1 can be used, while ignoring OUT2.

Two option pins allow the selection of output polarity and the insertion of a 'slosh filter' before the OUT pins, as shown in Figure 1-1.

1.1 ELECTRODE DRIVE

The internal ADC treats C_s as a floating transfer capacitor; as a direct result, the sense electrode can be connected to either SNS1 or SNS2 with no performance difference. The polarity of the charge buildup across C_s during a burst is the same in either case. C_s must be of within a certain range for proper operation.

It is possible to connect separate C_x and C_x' loads to SNS1 and SNS2 simultaneously, although the result is no different than if the loads were connected together at SNS2 (or SNS1). It is important to limit the amount of stray capacitance on both terminals, especially if the load C_x is already large, for example by minimizing trace lengths and widths so as not to exceed the C_x load specification and to allow for a larger sensing electrode size if so desired.

The PCB traces, wiring, and any components associated with or in contact with SNS1 and SNS2 will become proximity sensitive and should be treated with caution.

1.2 THRESHOLD POINTS

The QT114 employs twin threshold points set at both 250 (for T1) and 150 counts (for T2) of acquisition signal. The signal travels in an inverse direction: increasing amounts of C_x reduce the signal level; the baseline ('dry') signal should lie at 300 counts or more under most conditions. Calibration details are discussed fully in Section 3.2.

2 ELECTRODE DESIGN

The QT114 is designed to operate with a 'plateau' sensor, having a substantial surface area at each desired trip point, to create a capacitive 'step'.

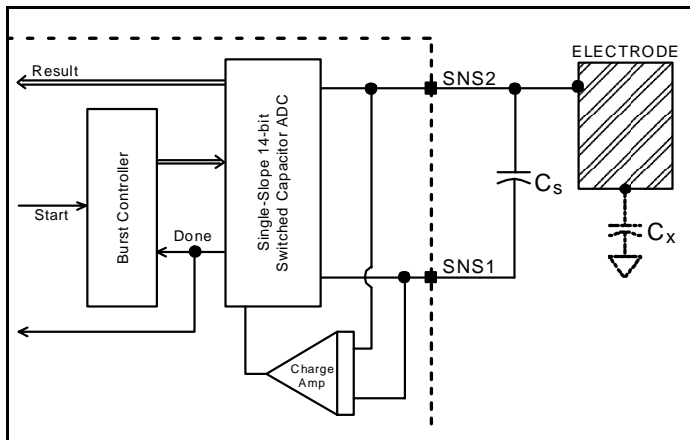

Figure 1-2 Internal Switching and Timing

As Figure 2-1 shows, a vertical strip sensor on the outside of a container (or a vertical, insulated rod in the fluid) will generate a long sloping signal. The desired trip point 'T' is subject to a great deal of variation in location if the sensing signal drifts much, for example due to changes in Cs or Cx over the operating temperature range.

Figure 2-2 shows the response from a horizontal strip of the same surface area; the signal exhibits a very rapid rise in signal between points I1 and I2. Variations in circuit gain or signal drift have much less of an effect on the trip point with this orientation.

In some cases (thin walled vessels for example) it may be sufficient to have a small round or square electrode patch on the exterior.

Figure 2-3 shows the response from a twin-level external electrode set. The use of two horizontal electrode planes or tiers creates well-defined trip points that can be used to sense both 'low' and 'high' levels. A crossing of threshold T1 will be reflected in the OUT1 signal, while T2 will be reflected on OUT2.

2.1 EXTERNAL ELECTRODES

External electrodes should be electrically conductive; metal foils and conductive carbon are both possible. Care should be taken that other objects or people near the vessel will not touch the electrode; in some cases shielding around the electrode with grounded metal will be required to prevent disturbances. If used, the shield element should be spaced apart from the electrode by an air gap or a low-density foam to reduce Cx loading.

The required surface area of the external electrode will depend on the amount of signal needed to bracket the detection threshold, which in turn will depend in part on Cs and stray Cx. External electrodes sensing through thick walls and/or sensing low permittivity fluids will require larger surface areas than those sensing water through thin plastic, for example. External electrodes are more likely to require potentiometer trimming to achieve reliable operation (Figure 1-1, also Section 3.2).

Note that external electrodes used with conductive solutions (i.e. aqueous liquids) do not measure the permittivity of the fluid: they actually measure the permittivity of the vessel wall, between 2 plates: the electrode (plate 1) and the fluid (plate 2, effectively a variable-area ground plate): if the fluid were to be replaced with mercury the signal would be unchanged. A 20% thickness variation in the vessel wall will therefore introduce about a 20% variation in the resulting capacitance; if the vessel wall cannot be controlled accurately enough in production, serious sensing errors may occur.

When external electrodes are used to sense non-aqueous substances (like oils or gasoline), the vessel wall dielectric becomes a lessor contributor to the overall signal, which is then heavily dominated by the permittivity of the fluid. The lower the permittivity of the fluid the greater its dominance.

2.2 INTERNAL PROBES

When used with aqueous fluids or other electrically conducting liquids, internal probes should be insulated with a plastic layer. See also Section 2.1 for a discussion of electrodes when used with conductive fluids. Aqueous probes should be 100% insulated, even on the cut end of a wire probe. The slightest pinhole of exposed metal anywhere on an immersed part of the probe will immediately convert the probe into a bare-metal probe (see Section 2.2.5).

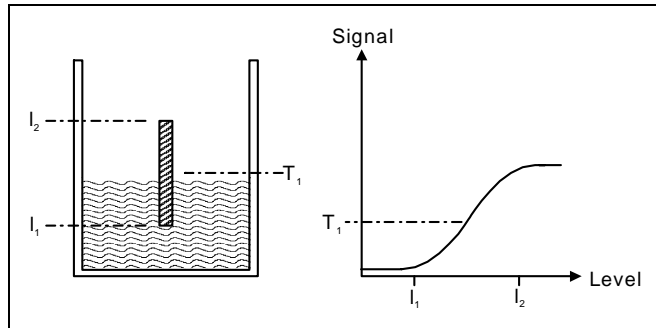

Figure 2-1 Signal vs. Level for an External Vertical Strip

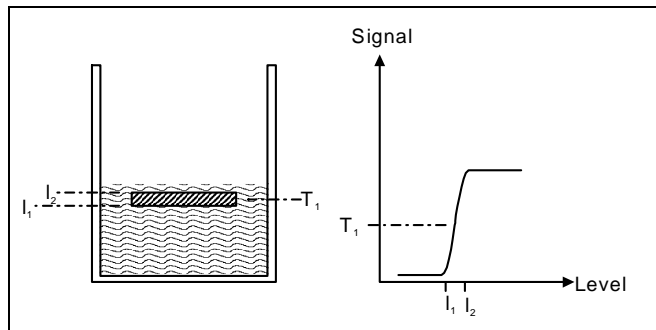

Figure 2-2 Signal vs. Level for an External Horizontal Strip

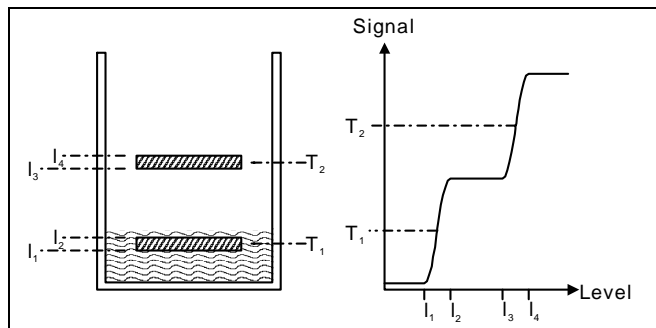

Figure 2-3 Signal vs. Level for Twin Horizontal Strips

Numerous types of internal point-level probes are possible.

2.2.1 DISC PROBES

The simplest internal geometry is probably a disc probe (Figure 2-4), having at least one planar surface ('tier') parallel to the fluid surface. The sensing error can be minimized by making the tier thin, so that the signal transitions abruptly higher (see Figure 2-2) as the fluid covers the tier.

A notable difficulty with disc probes is the task of insulating them with a uniform, repeatable thickness of insulation.

2.2.2 SPIRAL WIRE PROBES

A spiral solid-wire probe is simple to construct (Figure 2-5), and has the advantage of being pre-insulated in a wide choice of plastics from inexpensive PVC to PTFE. These probe types provide a large step-function of capacitance localized at the desired trip point, and are easy to form.

Spiral wire probes are most effective in water-based fluids; they are not as effective in oils and other nonconductive substances.

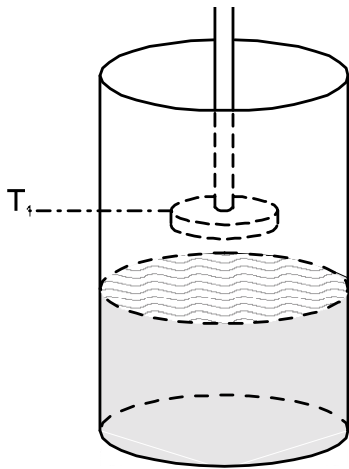

Figure 2-4 Single Level Internal Planar Probe

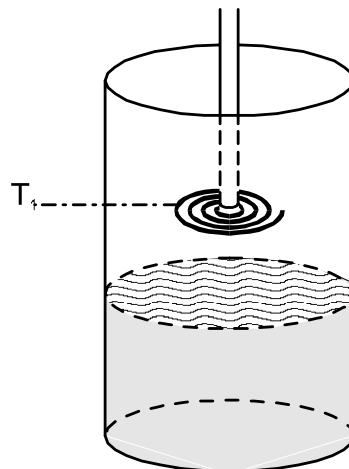

Figure 2-5 Single Level Internal Spiral Wire Probe

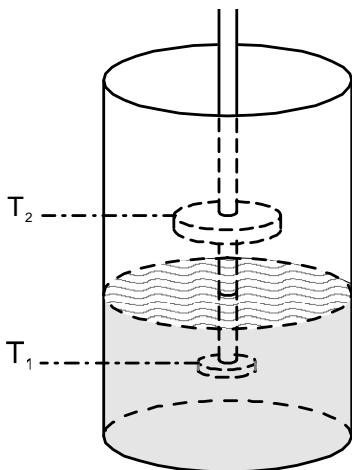

Figure 2-6 Twin-Level Internal Planar Probe

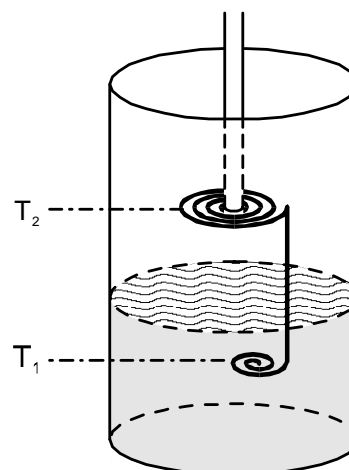

Figure 2-7 Twin-Level Internal Spiral Wire Probe

Spiral wire probes have the disadvantage of not being as rugged as a solid disc probe.

2.2.3 SIDE-ENTRY PROBES

Another type is a side-entry probe (Figure 2-8), which requires an entry point into the vessel wall, but may have the advantage of accessibility in certain cases. These can be made of simple metal rod, insulated in almost any plastic if required.

2.2.4 COAXIAL PROBES

Another type of internal probe is the coaxial probe (Figure 2-10); these are most useful with oils or similar fluids having a low dielectric constant; the inner rod is connected to the signal connection, and together with the outer grounded cylinder forms a capacitor whose dielectric is either air or oil. Keeping the gap between rod and cylinder to a minimum increases the 'gain' of the electrode.

Coaxial probes are more expensive to make, and can have problems with vibration if they are not constructed robustly. The outer cylinder should be perforated at key spots to allow fluid to fill and drain the cavity without trapping air bubbles inside. The outer cylinder can also be made of a wire mesh.

The outer cylinder does not have to be coated in plastic, even when used with water-based fluids. When used with oils, the inner rod does not require insulation either.

2.2.5 BARE METAL PROBES

Bare metal internal probes can be used, for example with nonconductive fluids like oils, without difficulty. This applies to all probe types described above.

Bare probes can also be used with aqueous fluids, but in these cases a 1,000pF (1nF) ceramic NPO capacitor should be inserted between the probe and the QT114 to block DC current flows.

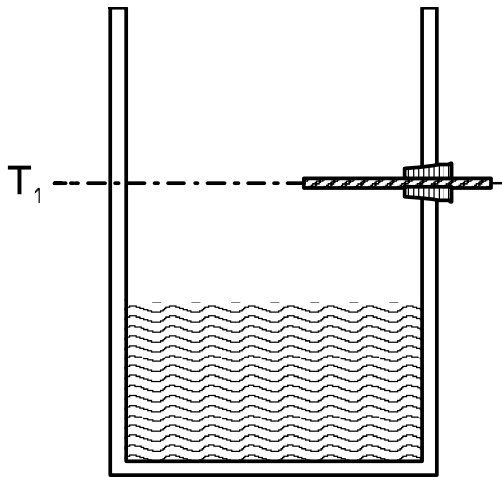

Figure 2-8 Single Internal Horizontal Probe

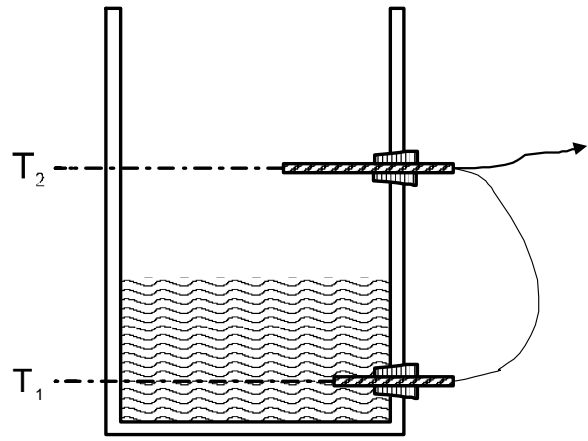

Figure 2-9 Twin-Level Internal Horizontal Probes

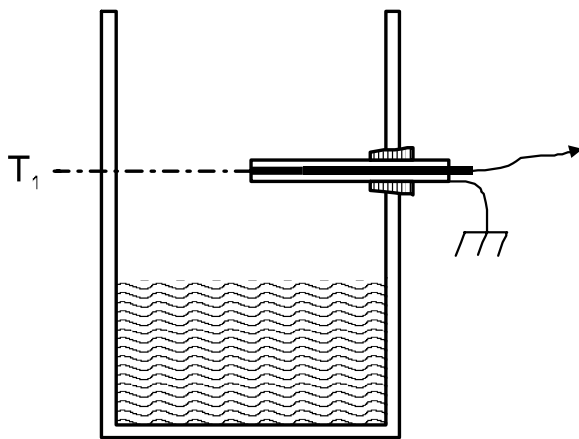

Figure 2-10 Coaxial Probe For Non-Aqueous Fluids

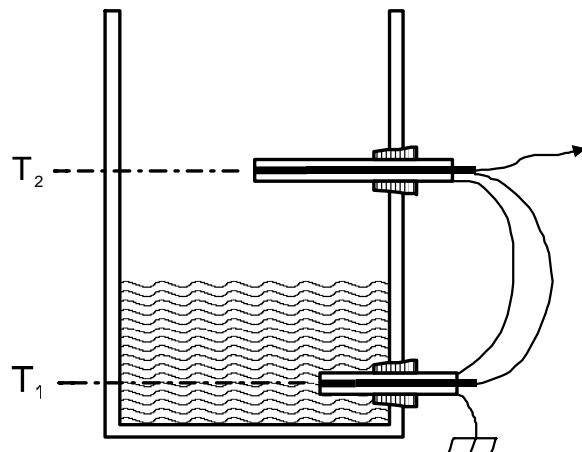

Figure 2-11 Twin-Level Coaxial Probes For Non-Aqueous Fluids

A bare internal probe used with conductive fluids and an in-line blocking capacitor will generate a huge, robust capacitive response that will not readily permit the use of a two-level probe due to signal saturation. Even the slightest amount of bare metal exposed to the fluid will usually generate an immediate, large response with aqueous fluids.

2.2.6 SCALE BUILDUP

Scale buildup on internal probes, bare or insulated, is not generally a problem since the sensor is still measuring capacitance, not conductance, and a reduction in conductivity around the probe will have minimal or no effect. Probe designs should be tested for this to be certain in all specific cases.

A legitimate concern with bare metal probes is the buildup of scale or other deposits at the entry point of the probe into the vessel. Such deposits may create a conductive surface path (especially if the vessel is made of metal) that may lead to false-positive trips. If the shank of the probe at the entry point is insulated enough so that conductive bridging cannot occur, this problem should be alleviated.

2.2.7 VISCOUS, CONDUCTIVE FILMS

Highly viscous fluids, or those having a high surface tension, and having substantial conductivity can fool some electrode designs into thinking that there is fluid present when there is not. This is a particular problem with external electrodes, where the residual films of certain types of fluids inside the container, electrically coupled to the fluid mass below, will create a substantial capacitive response. Internal probes are much more resistant to this effect since the fluid surface is guaranteed to become mechanically disconnected from the probe when the level drops. Coating the inner vessel surface with a smooth plastic of polyethylene or PTFE often has a very beneficial effect on this phenomenon.

2.3 SINGLE LEVEL SENSING

When sensing for a single trip point, the single electrode can be a simple horizontal strip on the outside of a nonmetallic vessel (Figure 2-2), or an internal probe having a substantial horizontal 'plateau' at the trip point (Figures 2-4, 2-5, 2-8, 2-10). When the strip or plateau is 'covered' with fluid the IC will detect on at least the OUT1 line; OUT2 can be ignored.

The trip point ideally occurs at the centerline of the internal probe or external electrode; this can be trimmed with a potentiometer if necessary (see Section 3.2). Making the electrode narrow and long (horizontally) will help keep the trip point localized within a narrow band.

2.4 DUAL LEVEL SENSING

When two trip levels are desired, for example for high-low limit sensing, the electrode or probe set should have two distinct tiers. A typical twin external electrode is shown in Figure 2-3 (they are connected together to the sense line); typical internal twin electrodes are shown in Figures 2-6, 2-7, 2-9, and 2-11. The response of a properly constructed 2-tier probe is shown in Figure 2-3.

Dual level electrodes should have an approximately 3:1 surface area ratio or more from T2 to T1; that is, the surface area at T2 should be at least 3x the surface area of the electrode at T1. There is no penalty for making T2 excessively large. The high ratio is required to overcome the QT114's decreasing gain with increasing Cx load (Figures 4-1, 4-2).

With internal dual-level probes where T1 and T2 are substantially separated, the intervening connection between the two levels should be more thickly insulated, for example with a thick plastic spacer, and any remaining internal gap inside the spacer should be filled with silicone sealant or epoxy. This will help to prevent the signal from rising much between the two levels, thus preserving a crisp bi-level response like that shown in Figure 2-3.

2.5 GROUNDING CONSIDERATIONS

In all cases ground reference coupling to the fluid must be made. In aqueous fluids, this can simply mean connecting the metal vessel to circuit ground, or inserting a bare metal element into the bottom of a plastic or glass vessel. The degree of galvanic contact is not critical, so scale and corrosion on the ground electrode are not of great concern especially if the 'connection' to the fluid is substantial enough.

If direct electrical contact to the fluid is not possible, a large piece of external metal can be bonded to the outside of the vessel and grounded. Once this is done, the signal should be monitored while the vessel is touched by hand; if the grounding is sufficient, the signal will not move or will move only slightly.

Very large vessels, even if not grounded, often do not require additional provision for grounding since the bottom surface area and free-space capacitance of the tank may be sufficient for ground return coupling.

In some cases (windshield washer tanks on cars for example) there will exist a water path to a chassis-grounded fitting somewhere downstream of the tank, or the water path may be labyrinthine enough to provide enough capacitive coupling to the grounded chassis even if it does not make galvanic contact. In these cases no further provision for fluid grounding is required. Simple experimentation will easily determine whether the existing amount of parasitic coupling to ground is enough to do the job.

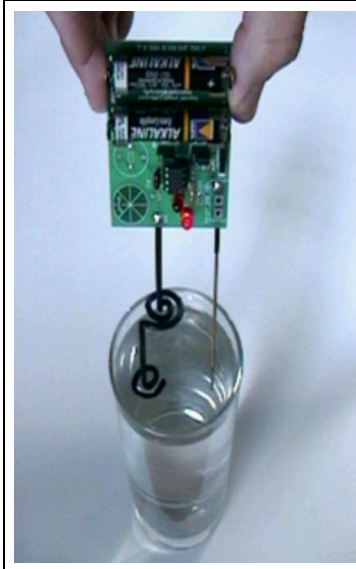

Figure 2-12 A two-tier spiral wire probe with ground rod

In the case of coaxial probes, the ground connection is inherent in the outer cylinder and no further ground connection is required.

3 PROCESSING AND CIRCUITRY

3.1 SLOSH FILTER

It is desirable to suppress rapid, multiple detections of fluid level generated by the surface movement of the fluid, for example in a moving vehicle. To accomplish this, the QT114 incorporates a detection integration counter that increments with each detection until a limit is reached, after which point one of the OUT lines is activated. If during a detection 'event' the fluid level falls below the electrode level (signal rises above a 'T' point in signal counts), the counter decrements back towards zero. Over a long interval the up and down counts will tend towards either zero or the limit, with the result being a statistical function of the number of detections vs. nondetections. If on average

there are more detections than nondetections, the counter will eventually make its way to the limit value and an OUT line will activate.

Once a detection has been established, the counter must find its way back to zero before the affected OUT line goes inactive, via the same process. Although the counter has a nominal reaction time of 15 seconds, in some cases it may take several minutes before the outcome is resolved depending on the violence of the fluid surface. If the fluid surface is stable however, it will only require 15 seconds to change the state of an OUT line.

Both OUT1 and OUT2 have their own independent slosh filters. Both are enabled or disabled in unison by strap option, pin 4, 'FILT' as follows:

FILT = Gnd	Slosh filter off
FILT = Vcc	Slosh filter on

FILT strapping can be changed 'on the fly'.

3.2 CALIBRATION

Both the T1 and T2 trip point values are hardwired internally as functions of counts of burst length. Sensitivity can be altered relative to these trip points by altering electrode size, geometry, degree of coupling to the fluid, and the value of Cs. Selecting an appropriate value of Cs for a given electrode geometry is essential for solid detection stability.

The QT114 employs dual threshold points set at 250 and 150 counts of acquisition signal. The signal travels in a reverse direction: increasing Cx reduces the signal counts; as a result, 250 counts of signal corresponds to the most sensitive or 'lower' setting (T1), and 150 the least sensitive 'upper' setting (T2).

The baseline signal count when the electrodes are 'dry' should begin at over 300 counts or more if possible. With a small, weakly coupled electrode the baseline signal can be trimmed to be closer to the 250 mark with a potentiometer to provide a higher apparent gain by closing the gap between the baseline and T1 (see below). The spread between T2 and T1 is fixed and cannot be separately trimmed.

Increasing Cs will increase the baseline counts, while increasing Cx will decrease it. When optimally tuned, each threshold point will be symmetrically bracketed by signal swing, with an intermediate count at about 200 between the two. Thus, the lower electrode level should cause a signal swing that (when 'dry') starts at 300 or more and when covered ends at about 200. The upper electrode when covered should generate a signal level of 100 or less.

There is a hysteresis of 3 counts around both T1 and T2.

The signal can be viewed for setup purposes with an oscilloscope via a 10x or FET probe connected to a 2M ohm resistor as shown in Figure 1-1; the resistor is required to reduce the loading effect of the scope probe capacitance. When viewed this way the signal will appear as a declining slope (Figure 3-1). The duration of the slope corresponds to the burst length: each count of burst takes approximately 7 microseconds on average. The 'low level' threshold at 250 counts is at 1750 microseconds from the start of the waveform, while the 150 count 'upper' threshold is at about 1050 microseconds from the start, at 3 volts Vcc. These trip points can be easily observed by monitoring the OUT lines while watching the signal on a scope, by increasing Cx loading until each OUT line activates in turn. FILT should be off to speed up response during testing.

The QT114's internal clock is dependent on Vcc; as a result, the threshold points in terms of delay time from the start of the burst are also substantially dependent on Vcc, but they are always fixed in terms of signal counts. A regulated power supply is strongly advised to maintain the proper calibration points.

Potentiometer adjustment: The external potentiometer shown in Figure 1-1 is optional and in most cases not required. In situations where the electrode pickup signal is weak, trimming may be necessary on a production basis to make the device sensitive enough. Trimming affects the baseline reference of the signal, and thus effects the amount of change in the signal required to cause a threshold crossing.

Potentiometer trimming is not a substitute for a good choice of Cs. In low signal situations Cs should still be determined by design to allow the baseline signal to be just beyond T1 as viewed on a scope. The trimmer should then be added and the baseline adjusted to the necessary final resting point.

The trimmer should never be adjusted so that the resistance from ground to SNS1 or SNS2 is less than 200K ohms. If the resistance is less than this amount, the gain of the circuit will be appreciably reduced and it may stop functioning altogether. A 200K resistor from the wiper to ground can be added to limit trim current at the extremes of wiper travel.

3.3 INTERFACING

3.3.1 OUT LINES AND POLARITY SELECTION

The QT114 has two OUT pins, OUT1 and OUT2, which correspond to the crossings of signal at T1 and T2 respectively. Each output will become active after the threshold is crossed, and after the slosh filter (if enabled) has settled to its final state. The polarity of the OUT lines is determined by pin 5, 'POL', as follows:

POL = Gnd	Outputs active low
POL = Vcc	Outputs active high

There is no timeout on these outputs; the OUT lines will remain active for as long as the thresholds are crossed.

The OUT lines can sink up to 5mA of non-inductive current. If an inductive load is used, like a small relay, the load should be diode clamped to prevent device damage.

POL strapping can be changed 'on the fly'.

Cycling and Stiction: Care should be taken when the QT114 and the loads are powered from the same supply, and the supply is minimally regulated. The QT114 derives its internal references from the power supply, and sensitivity shifts can occur with changes in Vcc, as happens when loads are switched on. This can induce detection 'cycling', whereby a trip point is crossed, the load is turned on, the supply sags, the trip is no longer sensed, the load is turned off, the supply rises and the trip point is reacquired, ad infinitum. To prevent this occurrence, the outputs should only be lightly loaded if the device is operated from a poorly regulated supply. Detection 'stiction', the opposite effect, can occur if a load is shed when an Out line becomes active.

3.3.2 HEARTBEAT™ OUTPUT

Both OUT lines have a full-time HeartBeat™ 'health' indicator superimposed on them. These operate by taking both OUT pins into a 3-state mode for 350µs once before every QT measurement burst. This state can be used to determine that the sensor is operating properly, or, it can be ignored using one of several simple methods.

If active-low polarity is selected, the HeartBeat indicator can be sampled by using a pulldown resistor on one or both OUT lines, and feeding the resulting negative-going pulse(s) into a counter, flip flop, one-shot, or other circuit (Figure 3-2). In this configuration, the pulldown resistor will create negative-going HeartBeat pulses when the sensor is not detecting fluid; when detecting fluid, the OUT line will remain low for the duration of the detection, and no pulse will be evident.

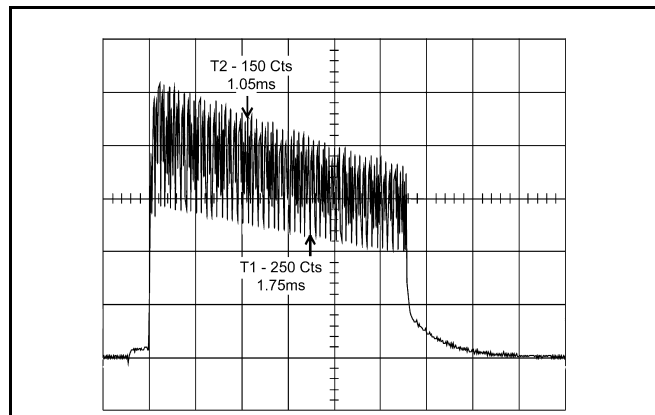
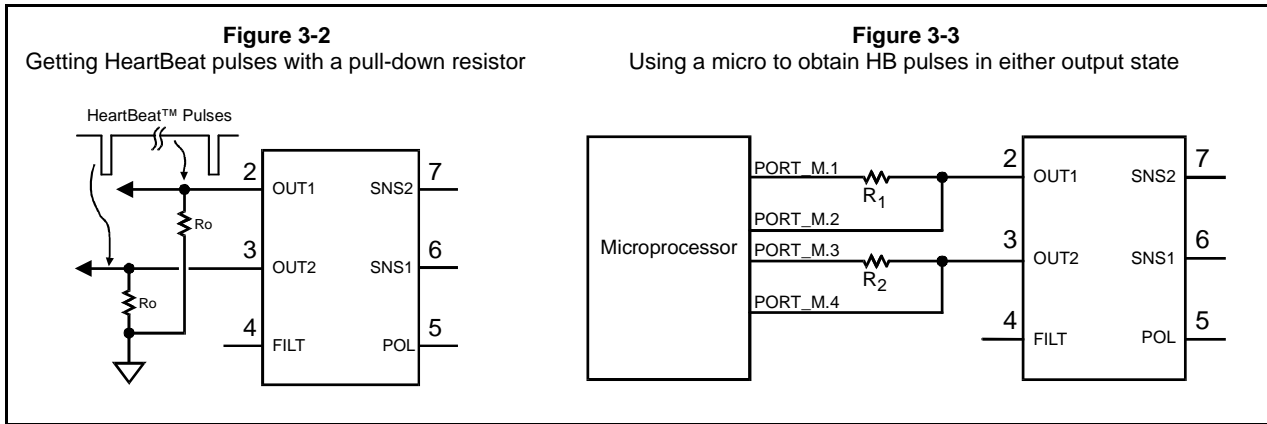

Figure 3-1 Burst Waveform at 2M Pickoff Resistor



Conversely, a pull-up resistor will show HeartBeat pulses when the line is low (detecting).

If active-high OUT polarity is selected, the pulses will only appear if there is a pull-up resistor in place and the fluid is not present (no detection, low output), or, if there is a pull-down resistor and the output is active (high output).

If the sensor is wired to a microprocessor as shown in Figure 3-3, the microprocessor can reconfigure the load resistor to either ground or Vcc depending on the output state of the QT114, so that the pulses are evident in either state with either POL setting.

The QT114 does have diode protection on its terminals which can absorb and protect the device from most induced discharges, up to 20mA; the usefulness of the internal clamping will depend on the probe insulation's dielectric properties, thickness, and the rise time of the transients. ESD dissipation can be aided further with an added diode protection network as shown in Figure 3-5. Because the charge and transfer times of the QT114 are relatively long, the circuit can tolerate very large values of Re1, as much as 50K ohms in most cases without affecting gain. The added diodes shown (1N4150, BAV99 or equivalent low-C diodes) will shunt the ESD transients away from the part, and Re1 will current-limit the rest into the QT114's own internal clamp diodes. C1 should be around 10µF if it is to absorb positive transients from a human body model standpoint without rising in value by more than 1 volt. If desired C1 can be replaced with an appropriate zener diode. Directly placing semiconductor transient protection devices or MOV's on the sense lead is not advised; these devices have extremely large amounts of parasitic C which will swamp the sensor.

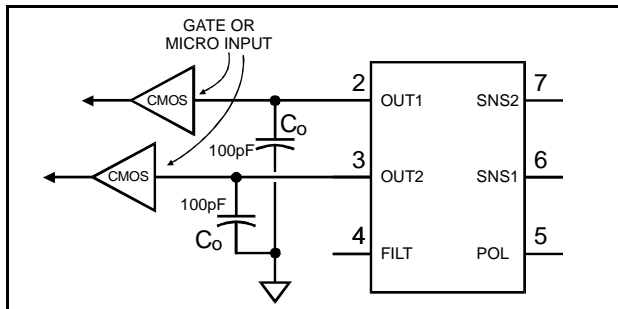

Figure 3-4 Eliminating HB Pulses

Electromechanical devices will ignore this short pulse. The pulse also has too low a duty cycle to visibly affect LED's. It can be filtered completely if desired, by adding an RC time constant to filter the output, or if interfacing directly and only to a high-impedance CMOS input, by doing nothing or at most adding a small noncritical capacitor from each used OUT line to ground (Figure 3-4).

3.4 ESD PROTECTION

In some installations the QT114 will be protected from direct static discharge by the insulation of the electrode and the fact that the probe may not be accessible to human contact.

However, even with probe insulation, transients can still flow into the electrode via induction, or in extreme cases, via dielectric breakdown. Some moving fluids (like oils) and powders can build up a substantial triboelectric charge directly on the probe surface.

Re2 functions to isolate the transient from the QT114's Vcc pin; values of around 1K ohms are reasonable.

As with all ESD protection networks, it is important that the transients be led away from the circuit. PCB ground layout is crucial; the ground connections to the diodes and C1 should all go back to the power supply ground or preferably, if available, a chassis ground connected to earth. The currents should not be allowed to traverse the area directly under the QT114.

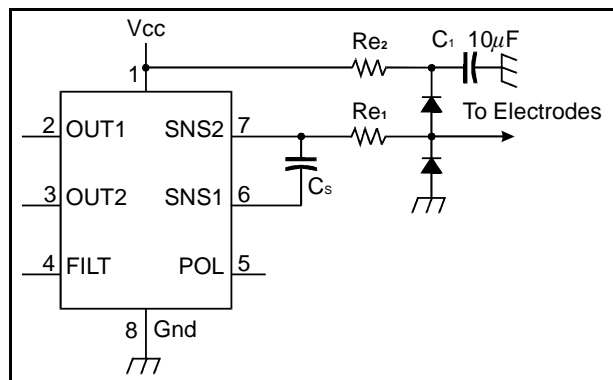

Figure 3-5 ESD Protection Network

If the QT114 is connected to an external circuit via a long cable, it is possible for ground-bounce to cause damage to the OUT pins; even though the transients are led away from the QT114 itself, the connected signal or power ground line will act as an inductor, causing a high differential voltage to build up on the OUT wires with respect to ground. If this is a possibility, the OUT pins should have a resistance in series with them on the sensor PCB to limit current; this resistor should be as large as can be tolerated by the load.

3.5 SAMPLE CAPACITOR

Charge sampler Cs should be a stable grade of capacitor, like PPS film, NPO ceramic, or polycarbonate. The acceptable Cs range is anywhere from 10nF to 100nF (0.1uF) and its required value will depend on load Cx. In some cases, to achieve the 'right' value, two or more capacitors may need to be wired in parallel.

The value of Cs controls the calibration point (Section 3.2) and its selection should not be taken lightly.

3.6 POWER SUPPLY

The power supply can range from 2.5 to 5.0 volts. At 3 volts current drain averages less than 20uA in most cases. Operation can be from batteries, especially stable Lithium cells, but be cautious about loads causing supply droop (Section 3.3.1).

If the power supply is shared with another electronic system, care should be taken to assure that the supply is free of digital spikes, sags, and surges which can adversely affect the QT114.

If desired, the supply can be regulated using a conventional low current regulator, for example CMOS regulators that have nanoamp quiescent currents. The voltage regulator should not have a minimum load specification, which almost certainly will be violated by the QT114's low current requirement.

Since the QT114 operates in a burst mode, almost all the power is consumed during the course of each burst. During the time between bursts the sensor is quiescent.

3.6.1 MEASURING SUPPLY CURRENT

Measuring average power consumption is a fairly difficult task, due to the burst nature of the QT110's operation. Even a good quality RMS DMM will have difficulty tracking the low burst rate.

The simplest method for measuring average current is to replace the power supply with a large value low-leakage electrolytic capacitor, for example 2,700uF. 'Soak' the capacitor by connecting it to a bench supply at the desired operating voltage for 24 hours to form the electrolyte and reduce leakage to a minimum. Connect the capacitor to the QT114 circuit at T=0, making sure there will be no detections during the measurement interval and no loads on the OUT pins; at T=30 seconds measure the capacitor's voltage with a DMM. Repeat the test without a load to measure the capacitor's internal leakage, and subtract the internal leakage result from the voltage droop measured during the QT114 load test. Be sure the DMM is connected only at the end of each test, to prevent the DMM's own impedance from contributing to the capacitor's discharge.

Supply drain can be calculated from the adjusted voltage droop using the basic charge equation:

$$i = \frac{\Delta VC}{t}$$

where C is the supply capacitor's value, t is the elapsed measurement time in seconds, and DV is the adjusted voltage droop on C.

3.7 PC BOARD LAYOUT

There are only a few important issues for the PCB layout. For RF susceptibility reasons it should be compact, and if possible use SMT components and a ground plane (Section 3.8). Lines for SNS1 and SNS2 should be short and not run directly over the ground plane to reduce Cx loading, which adversely affects sensitivity (Section 3.2). ESD issues should be taken into account (Section 3.4). The board should not be located in a place where there are wild temperature swings which can cause excessive drift in Cs. The voltage regulator should be located nearby and should only be shared with other circuits that do not induce supply sags or spikes (Section 3.6).

3.8 RFI / EMI ISSUES

3.8.1 SUSCEPTIBILITY

The QT114 is remarkably resistant to RF fields. With enough field strength at frequencies above 100MHz, internal protection diode conduction at the SNS1 and SNS2 pins can occur and destroy the charge-transfer process, causing false detections or desensitization, or alternating cycles of both.

Susceptibility can be dramatically reduced by adding a resistor in series with the Sense line, between 2K to 60K ohms depending on load Cx. This has the effect of creating a natural low-pass filter in conjunction with the Cs capacitor to filter out external RF components. If an ESD network is used (Figure 3-5), the added resistor should be placed between the clamp diodes and the sense probe, and Re1 should be made very small, 1K ohms or less, or even eliminated. With a 50pF load the added resistance should be no greater than about 5.6K ohms, while at 10pF it can be as high as 27K; the value should be chosen to allow at least 7 RC time constants of settling with a 2us charge time for efficient, stable operation. 5% tolerance resistors can be used.

A great number of susceptibility problems can be traced to RF fields coupling directly to components on the PCB. Therefore a shielded, grounded housing is recommended to reduce susceptibility. The use of SMT circuitry is also highly recommended; physically reducing lead lengths of the wiring traces and pins, along with a poured-copper ground plane, will dramatically reduce the coupling of external RF fields.

3.8.2 RF EMISSIONS

RF emissions are extremely weak, as the charge-transfer pulse frequency is only about 170kHz and the bursts are sparsely spaced, so that the average spectral power density is extremely low. The addition of a series resistor for EMI reasons (above) will dramatically reduce edge rise and fall times, resulting in an even greater reduction in emitted RF energy.

4.1 ABSOLUTE MAXIMUM SPECIFICATIONS

Operating temp. as designated by suffix
 Storage temp. -55°C to +125°C
 Vcc. -0.5 to +6.5V
 Max continuous pin current, any control or drive pin ±20mA
 Short circuit duration to ground, any pin. infinite
 Short circuit duration to Vcc, any pin. infinite
 Voltage forced onto any pin. -0.6V to (Vcc + 0.6) Volts

4.2 RECOMMENDED OPERATING CONDITIONS

Vcc. +2.5 to 5.25V
 Supply ripple+noise. 20mV p-p max
 Load capacitance. 0 to 50pF
 Cs value. 10nF to 100nF

4.3 AC SPECIFICATIONS Vcc = 3.0, Ta = recommended operating range

Parameter	Description	Min	Typ	Max	Units	Notes
T _{PC}	Charge duration		2		µs	
T _{PT}	Transfer duration		4		µs	
T _{BS}	Burst spacing interval		75		ms	
T _{BL}	Burst length, time	0		3.5	ms	
N _{LC}	Maximum burst length counts		500		counts	
T _R	Response time		80		ms	Slosh filter disabled
T _Q	QT pulse spacing	6		14	µs	
T _R	Pulse edge risetime		6		ns	Cx = 5pF
T _F	Pulse edge falltime		4		ns	Cx = 5pF
T _{HB}	Heartbeat pulse width	300	350	400	µs	

4.4 SIGNAL PROCESSING

Description	Min	Typ	Max	Units	Notes
Threshold, T1		250		counts	Note 1
Threshold, T2		150		counts	Note 1
Hysteresis		3		counts	Note 1
Slosh filter length, time		15		seconds	Note 2
Slosh filter length, counts		190		counts	Note 1

Note 1: Counts of burst

Note 2: Uninterrupted detection / non-detection: Strap option.

4.5 DC SPECIFICATIONS

V_{CC} = 3.0V, C_s = 10nF, C_x = 10pF, T_A = recommended range, unless otherwise noted

Parameter	Description	Min	Typ	Max	Units	Notes
V _{CC}	Supply voltage	2.45		5.25	V	
I _{DD}	Supply current		20		μA	
V _{DDS}	Supply turn-on slope	100			V/s	Required for proper startup
V _{IL}	Low input logic level			0.8	V	FILT, POL
V _{HL}	High input logic level	2.2			V	FILT, POL
V _{OL}	Low output voltage			0.6	V	OUT1, OUT2, 5mA sink
V _{OH}	High output voltage	V _{DD} -0.8			V	OUT1, OUT2, 1mA source
I _{IL}	Input leakage current			±1	μA	FILT, POL
C _x	Load capacitance range	0		50	pF	
S[1]	Sensitivity [T1]		0.125		pF/count	C _s = 20nF, C _x = 10pF
S[2]	Sensitivity [T2]		0.33		pF/count	C _s = 20nF, C _x = 30pF

FIGURE 4-1

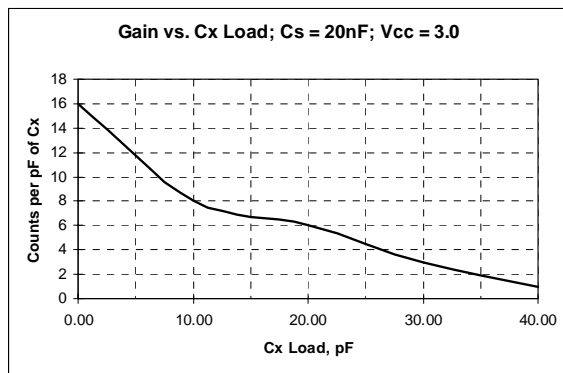
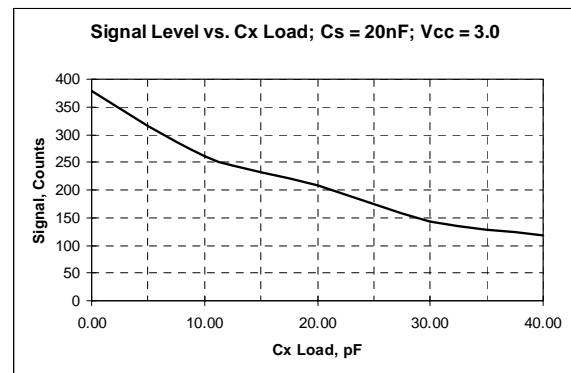
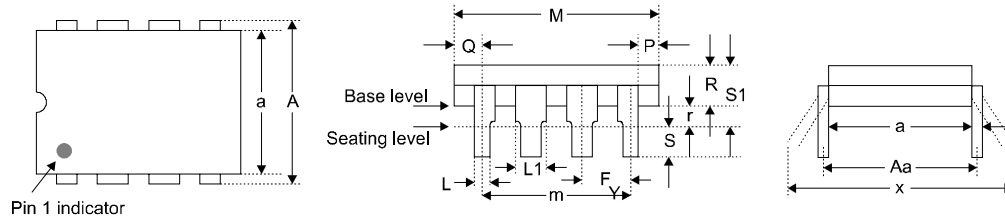

FIGURE 4-2



4.6 MECHANICAL



Package type: 8-pin Dual-In-Line						
SYMBOL	Millimeters			Inches		
	Min	Max	Notes	Min	Max	Notes
a	6.096	7.112		0.24	0.28	
A	7.62	8.255		0.3	0.325	
M	9.017	10.922	Typical	0.355	0.43	Typical
m	7.62	7.62	BSC	0.3	0.3	BSC
Q	0.889	-		0.035	-	
P	0.254	-		0.01	-	
L	0.355	0.559		0.014	0.022	
L1	1.397	1.651		0.055	0.065	
F	2.489	2.591	Typical	0.098	0.102	Typical
R	3.048	3.81		0.12	0.15	
r	0.381	-		0.015	-	
S	3.048	3.556		0.12	0.14	
S1	-	4.064		-	0.16	
Aa	7.62	7.062	BSC	0.3	0.3	BSC
x	8.128	9.906		0.32	0.39	
Y	0.203	0.381		0.008	0.015	

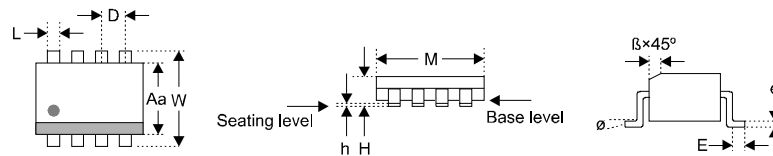

Package type: 8-pin SOIC						
SYMBOL	Millimeters			Inches		
	Min	Max	Notes	Min	Max	Notes
M	4.800	4.979		0.189	0.196	
W	5.816	6.198		0.229	0.244	
Aa	3.81	3.988		0.15	0.157	
H	1.371	1.728		0.054	0.068	
h	0.101	0.762		0.004	0.01	
D	1.27	1.27	BSC	0.050	0.05	BSC
L	0.355	0.483		0.014	0.019	
E	0.508	1.016		0.02	0.04	
e	0.19	0.249		0.007	0.01	
β	0.381	0.762		0.229	0.03	
∅	0°	8°		0°	8°	

5 ORDERING INFORMATION

PART	TEMP RANGE	PACKAGE	MARKING
QT114-DG	0 - 70C	PDIP Lead-Free	QT114 or QT114-DG
QT114-ISG	-40 - 85C	SOIC-8 Lead-Free	QT114 or QT1G

6 MOISTURE SENSITIVITY LEVEL (MSL)

MSL Rating	Peak Body Temperature	Specifications
MSL1	260°C	IPC/JEDEC J-STD-020C



Copyright © 1999-2006 QRG Ltd. All rights reserved
Patented and patents pending

Corporate Headquarters

1 Mitchell Point
Ensign Way, Hamble SO31 4RF
Great Britain
Tel: +44 (0)23 8056 5600 Fax: +44 (0)23 8045 3939

www.qprox.com

North America

651 Holiday Drive Bldg. 5 / 300
Pittsburgh, PA 15220 USA
Tel: 412-391-7367 Fax: 412-291-1015

The specifications set out in this document are subject to change without notice. All products sold and services supplied by QRG are subject to QRG's Terms and Conditions of sale and services. QRG patents, trademarks and Terms and Conditions can be found online at <http://www.qprox.com/about/legal.php>. Numerous further patents are pending, one or more which may apply to this device or the applications thereof.

QRG products are not suitable for medical (including lifesaving equipment), safety or mission critical applications or other similar purposes. Except as expressly set out in QRG's Terms and Conditions, no licenses to patents or other intellectual property of QRG (express or implied) are granted by QRG in connection with the sale of QRG products or provision of services. QRG will not be liable for customer product design and customers are entirely responsible for their products and applications which incorporate QRG's products.