

Features and Benefits

- Small Plastic Package (SOT-23, 4-SIP-VA, TO-92)
- Quad Switched Hall Plate / Chopper Stabilized Amplifier
- Ratiometric Output for A/D Interface
- Low Quiescent Voltage Thermal Drift

Applications

- Linear Position Sensing
- Rotary Position Sensing
- Current Sensing

Ordering Information

Part No.	Sensitivity	Voq	TC	Temp. Range	Package	Nb pins
MLX90242LUA-CC03	40 mV/mT ($\pm 500G$)	2.50 V	700 ppm/ $^{\circ}C$	-40C to 150C	UA	3
MLX90242LVA-CC03	40 mV/mT ($\pm 500G$)	2.50 V	700 ppm/ $^{\circ}C$	-40C to 150C	VA	4
MLX90242ESO-BC03	15 mV/mT ($\pm 1300G$)	2.50 V	-	-40C to 85C	SO	3
MLX90242ESO-CC03	40 mV/mT ($\pm 500G$)	2.50 V	-	-40C to 85C	SO	3

1. Functional Diagram

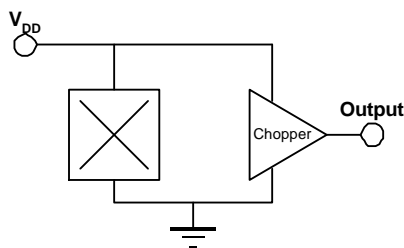

Package	Pin1	Pin2	Pin 3	Pin4	Slope
SOT23	V _{DD}	Out	V _{SS}		Positive
UA	V _{DD}	V _{SS}	Out		Negative
VA	V _{DD}	n/c	V _{SS}	Out	Positive

2. Description

The MLX90242 is a CMOS Linear Hall Effect sensor IC. It possesses active error correction circuitry which virtually eliminates the offset errors normally associated with analog Hall Effect devices.

The ratiometric output voltage is proportional to the supply voltage. When using the supply voltage as a reference for an A/D converter, fluctuations of $\pm 10\%$ in supply voltage will not affect accuracy. For a positive slope, the voltage at the output will increase as a South magnetic field is applied to the branded face of the MLX90242. Conversely, the voltage output will decrease in the presence of a North magnetic field. For a negative slope, the voltage at the output will increase as a North magnetic field is applied to the branded face of the MLX90242. Conversely, the voltage output will decrease in the presence of a South magnetic field.

TABLE OF CONTENTS

FEATURES AND BENEFITS	1
APPLICATIONS	1
ORDERING INFORMATION	1
1. FUNCTIONAL DIAGRAM	1-1
2. DESCRIPTION	2-1
3. GLOSSARY OF TERMS	3
4. ABSOLUTE MAXIMUM RATINGS	3
5. MLX90242 ELECTRICAL SPECIFICATIONS	4
6. MLX90242 MAGNETIC SPECIFICATIONS	4
7. APPLICATIONS INFORMATION.....	5
8. INSTALLATION COMMENTS	5
9. RELIABILITY INFORMATION.....	5
10. ESD PRECAUTIONS	6
11. PACKAGE INFORMATION.....	6

3. Glossary of Terms

- Gauss, Tesla: Two units to quantify a magnetic flux density. Conversion: 1 mT = 10 Gauss
- Voq: Quiescent output voltage. Output voltage for B = 0.

4. Absolute Maximum Ratings

Supply Voltage (Over Voltage), V _{DD}	7.0 V
Output Current Short to V _{DD}	5 mA
Output Current Short to V _{SS}	0.5 mA
Output Pin Short to V _{SS} Pin	Infinite
Output Over Voltage	8 V
Operating Temperature Range, T _A	-40°C to 150°C
Storage Temperature Range, T _S	-55°C to 150°C
Maximum Junction Temp, T _J	170°C
Magnetic Flux Density	Infinite

Exceeding the absolute maximum ratings may cause permanent damage. Exposure to absolute-maximum-rated conditions for extended periods may affect device reliability.

5. MLX90242 Electrical Specifications

DC Operating Parameters. L: $T_A = -40$ to 150°C , E: $T_A = -40$ to 85°C
 $V_{DD} = 5.0\text{V}$ (Unless otherwise specified)

Parameter	Symbol	Test Conditions	Min	Typ	Max	Units
Supply Voltage	V_{DD}	Operating	4.5	5.0	5.5	V
Supply Current	I_{DD}	$B = 0, V_{DD} = 5\text{V}, I_{OUT} = 0$	1.8	2.5	4.5	mA
Output Current	I_{OUT}	$V_{DD} = 5\text{V}$ Pull-up = 5 k Ω , Pull-down = 50 k Ω	-1.0	-	0.1	mA
Quiescent Output Voltage	V_{OQ}	$B = 0, T_A = 25^\circ\text{C}$	2.4	2.5	2.6	V
Output Voltage	V_{OH}	$V_{DD} = 5\text{V}, I_{OUT} = -1.0\text{ mA}$	4.75			V
Output Voltage	V_{OL}	$V_{DD} = 5\text{V}, I_{OUT} = 0.1\text{ mA}$			0.25	V
Response Time	t_r	$V_{DD} = 5\text{V}, V_{out}$ from V_{OQ} to V_{OH}/V_{OL} without load		400	800	μs
Noise (RMS)				5	10	mV
Output Resistance	R_{OUT}			20		Ω
Linearity Error	Le				0.5	%V $_{DD}$

6. MLX90242 Magnetic Specifications

L: $T_A = -40$ to 150°C , E: $T_A = -40$ to 85°C
 $V_{DD} = 5.0\text{V}$ (Unless otherwise specified)

Parameter	Symbol	MLX90242LUA-CC03			MLX90242LVA-CC03			MLX90242ESO-BC03			MLX90242ESO-CC03		
		Min	Typ	Max	Min	Typ	Max	Min	Typ	Max	Min	Typ	Max
Thermal V_{OQ} Drift ⁽¹⁾ (mV)	$D^T V_{OQ}$	-25		25	-25		25	+/- 25 ⁽²⁾			+/- 25 ⁽²⁾		
Sensitivity, $T_A = 25^\circ\text{C}$ (mV/mT)	S	33.2	39.0	44.9	35.3	41.5	47.7	11.5	15	17.3	33.2	39.0	44.9
TC of Sensitivity (ppm/ $^\circ\text{C}$)	TC_S	430	680	930	430	680	930	680 ⁽²⁾			680 ⁽²⁾		

(1) $B = 0, T_A = -40$ to 150°C

(2) For ESO package, TC of Sensitivity and Thermal V_{OQ} Drift are not fully tested and therefore cannot be specified. Characterization and statistic data can be provided by Melexis upon request.

7. Applications Information

C1 and C2 values can be trimmed to satisfied EMC requirements according to the environment (PCB, connectors,...).
The output rise time is affected for large capacitor C2, depending of the couple R1;C2.

8. Installation Comments

1.) Avoid mechanical stress on leads or package.

Stress may cause V_{OQ} shift.

- A.) Avoid bending leads at the package interface.
- B.) Support the leads by clamping, when bending.
- C.) Avoid gluing device to another material.

This may cause temperature-related stress.

- 2.) CMOS products are static sensitive devices, please observe ESD precautions.
- 3.) Observe temperature limits during soldering

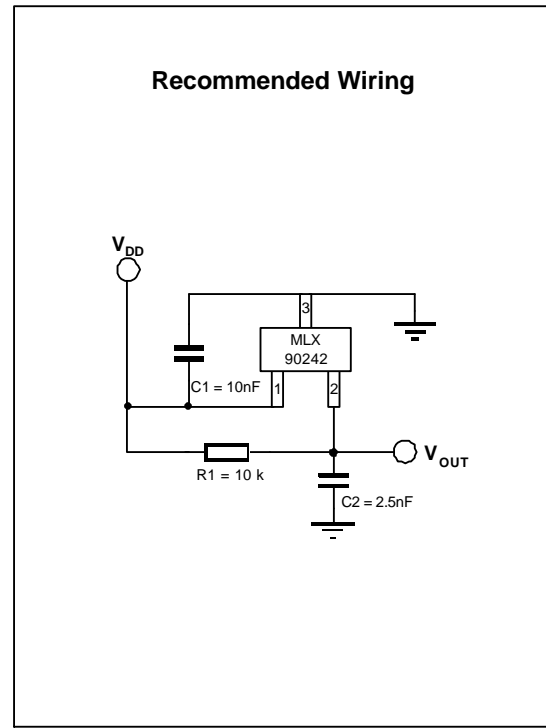

9. Reliability Information

Melexis devices are classified and qualified regarding suitability for infrared, vapor phase and wave soldering with usual (63/37 SnPb-) solder (melting point at 183degC).
The following test methods are applied:

IPC/JEDEC J-STD-020A (issue April 1999)

Moisture/Reflow Sensitivity Classification For Nonhermetic Solid State Surface Mount Devices

CECC00802 (issue 1994)

Standard Method For The Specification of Surface Mounting Components (SMDs) of Assessed Quality

MIL 883 Method 2003 / JEDEC-STD-22 Test Method B102

Solderability

For all soldering technologies deviating from above mentioned standard conditions (regarding peak temperature, temperature gradient, temperature profile etc) additional classification and qualification tests have to be agreed upon with Melexis. For process using through hole components, a temperature profile of 235 Deg.C during 30 seconds maximum is tolerated.

The application of Wave Soldering for SMD's is allowed only after consulting Melexis regarding assurance of adhesive strength between device and board. Please contact MLX for Ua part used as SMD device.

For more information on manufacturability/solderability see quality page at our website:

<http://www.melexis.com/>

10. ESD Precautions

Electronic semiconductor products are sensitive to Electro Static Discharge (ESD). Always observe Electro Static Discharge control procedures whenever handling semiconductor products.

11. Package Information

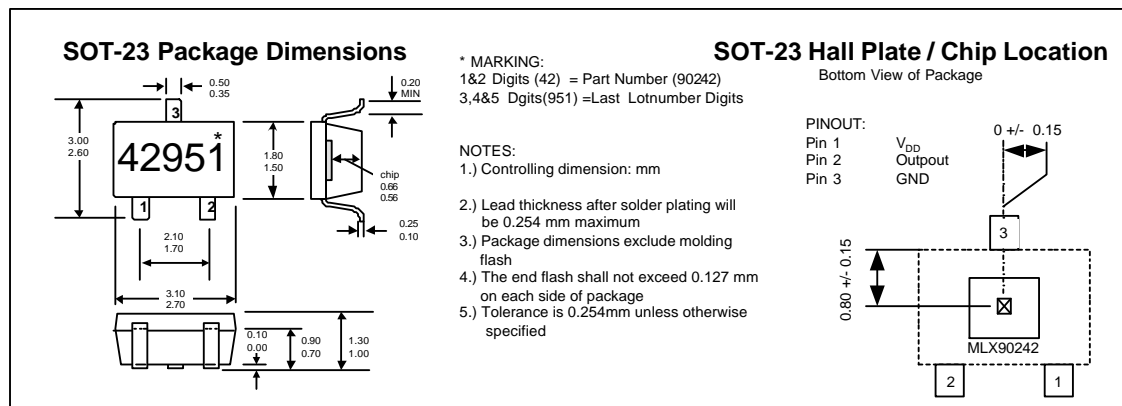
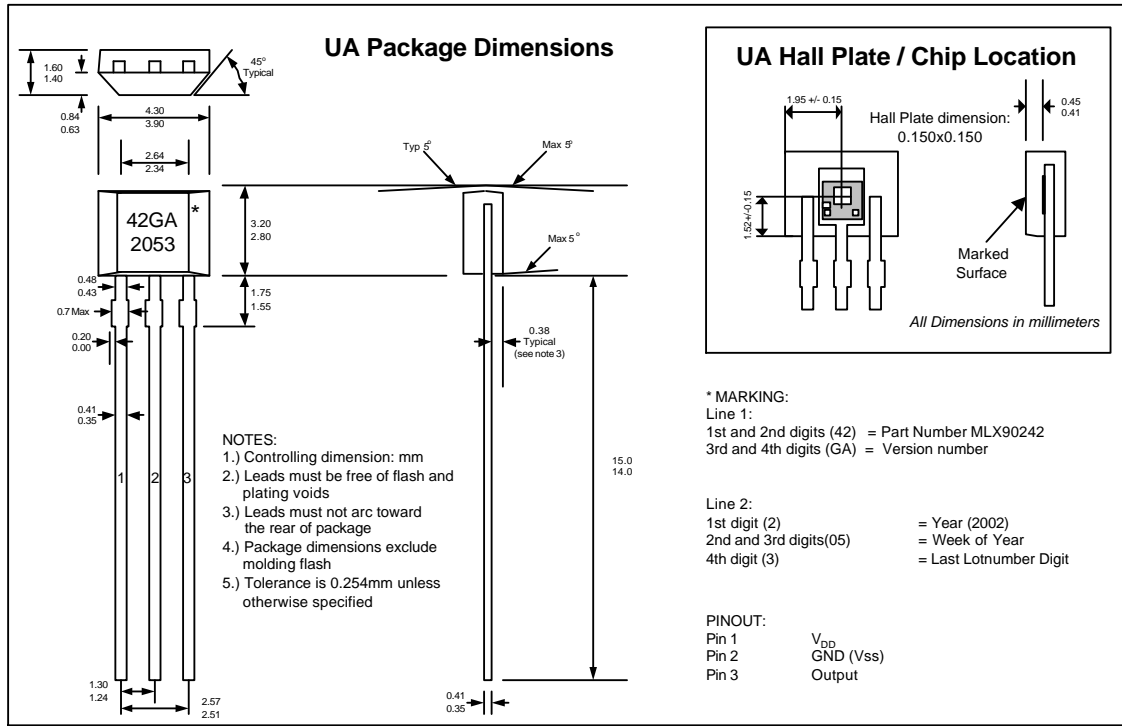

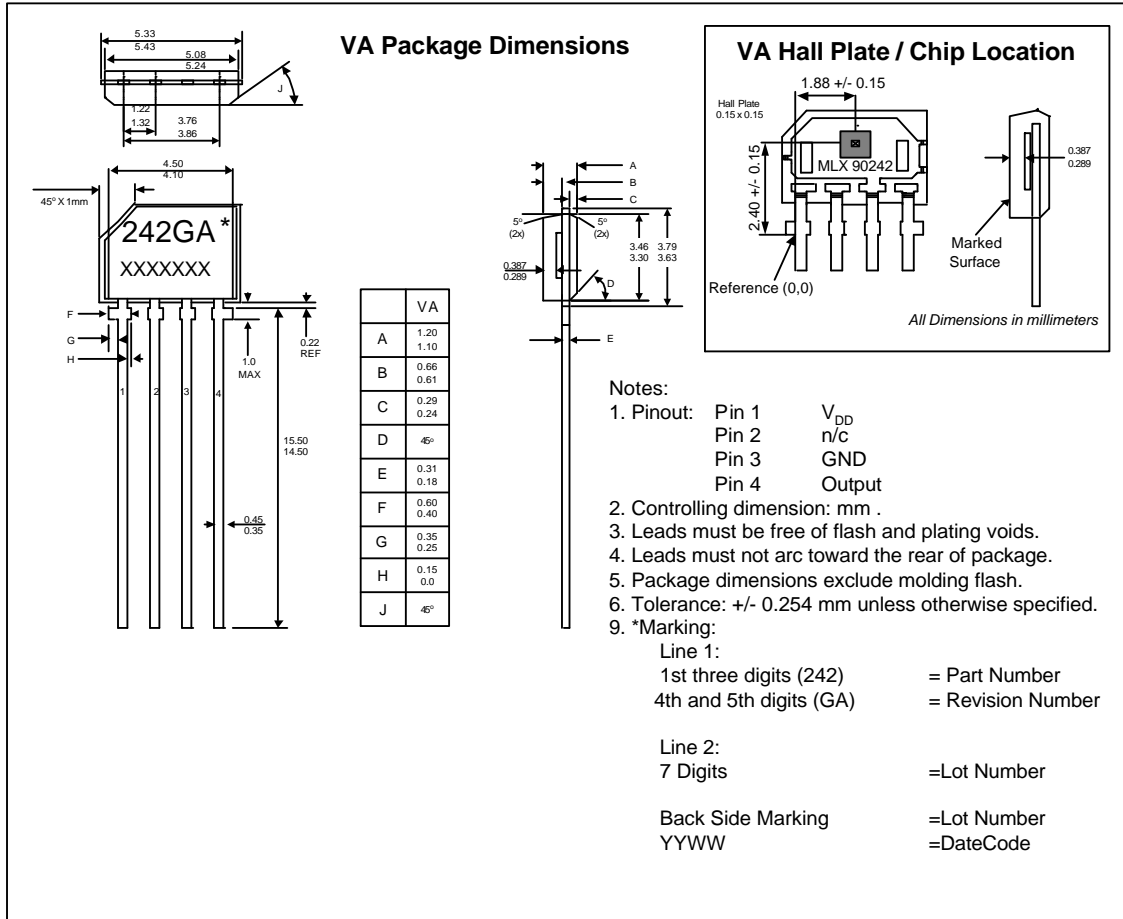

Go to our website at
www.melexis.com

Or for additional information contact Melexis Direct:

Europe and Japan:
Phone: +32 13 67 0495
E-mail: sales_europe@melexis.com

All other locations:
Phone: +1 603 223 2362
E-mail: sales_usa@melexis.com

QS9000, VDA6.1 and ISO14001 Certified