

## Features

- Fast Read Access Time - 45 ns
- Low Power CMOS Operation
  - 100  $\mu$ A max. Standby
  - 30 mA max. Active at 5 MHz
- JEDEC Standard Packages
  - 44-Lead PLCC
  - 40-Lead TSOP (10mm x 14mm)
- 5V  $\pm$  10% Power Supply
- High Reliability CMOS Technology
  - 2000V ESD Protection
  - 200 mA Latchup Immunity
- Rapid™ Programming Algorithm - 50  $\mu$ s/word (typical)
- CMOS and TTL Compatible Inputs and Outputs
- Integrated Product Identification Code
- Commercial and Industrial Temperature Ranges

## Description

The AT27C516 is a low-power, high performance 524,288 bit one-time programmable read only memory (OTP EPROM) organized 32K by 16 bits. It requires only one 5V power supply in normal read mode operation. Any word can be accessed in less than 45 ns, eliminating the need for speed reducing WAIT states. The by-16 organization make this part ideal for high-performance 16 and 32 bit microprocessor systems.

(continued)

**512K (32K x 16)  
OTP CMOS  
EPROM**

## Pin Configurations

Pin Name	Function
A0 - A14	Addresses
O0 - O15	Outputs
$\overline{CE}$	Chip Enable
$\overline{OE}$	Output Enable
$\overline{PGM}$	Program Strobe
NC	No Connect

Note: Both GND pins must be connected.

PLCC Top View

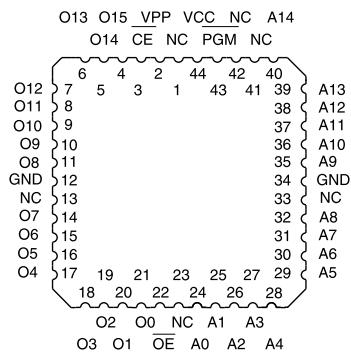

Note: PLCC Package Pins 1 and 23 are DON'T CONNECT.

TSOP Top View  
Type 1

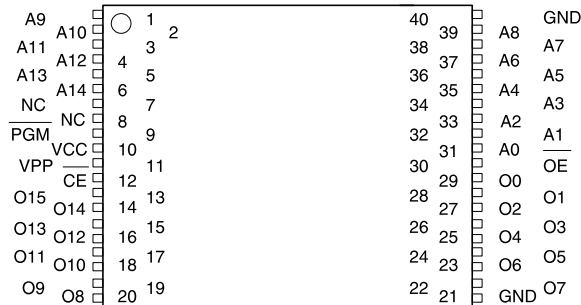

## Description (Continued)

In read mode, the AT27C516 typically consumes 15 mA. Standby mode supply current is typically less than 10  $\mu$ A.

The AT27C516 is available in industry standard JEDEC-approved one-time programmable (OTP) plastic PLCC and TSOP packages. The device features two-line control ( $\overline{CE}$ ,  $\overline{OE}$ ) to eliminate bus contention in high-speed systems.

With 32K word storage capability, the AT27C516 allows firmware to be stored reliably and to be accessed by the system without the delays of mass storage media.

Atmel's 27C516 have additional features to ensure high quality and efficient production use. The Rapid™ Programming Algorithm reduces the time required to program the part and guarantees reliable programming. Programming time is typically only 50  $\mu$ s/word. The Integrated Product Identification Code electronically identifies the device and manufacturer. This feature is used by industry standard programming equipment to select the proper programming algorithms and voltages.

## System Considerations

Switching between active and standby conditions via the Chip Enable pin may produce transient voltage excursions. Unless accommodated by the system design, these transients may exceed data sheet limits, resulting in device non-conformance. At a minimum, a 0.1  $\mu$ F high frequency, low inherent inductance, ceramic capacitor should be utilized for each device. This capacitor should be connected between the V<sub>CC</sub> and Ground terminals of the device, as close to the device as possible. Additionally, to stabilize the supply voltage level on printed circuit boards with large EPROM arrays, a 4.7  $\mu$ F bulk electrolytic capacitor should be utilized, again connected between the V<sub>CC</sub> and Ground terminals. This capacitor should be positioned as close as possible to the point where the power supply is connected to the array.

## Block Diagram

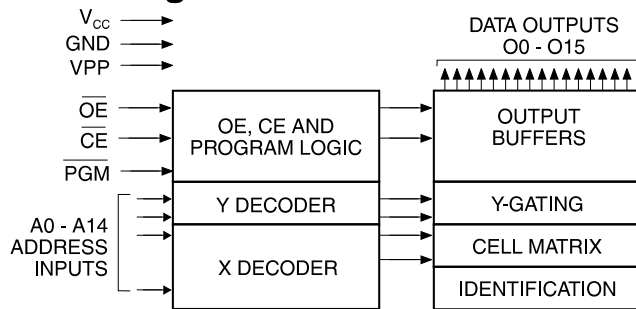

## Absolute Maximum Ratings\*

Temperature Under Bias .....	-55°C to +125°C
Storage Temperature.....	-65°C to +150°C
Voltage on Any Pin with Respect to Ground.....	-2.0V to +7.0V <sup>(1)</sup>
Voltage on A9 with Respect to Ground .....	-2.0V to +14.0V <sup>(1)</sup>
V <sub>PP</sub> Supply Voltage with Respect to Ground.....	-2.0V to +14.0V <sup>(1)</sup>

\*NOTICE: Stresses beyond those listed under “Absolute Maximum Ratings” may cause permanent damage to the device. This is a stress rating only and functional operation of the device at these or any other conditions beyond those indicated in the operational sections of this specification is not implied. Exposure to absolute maximum rating conditions for extended periods may affect device reliability.

Note: 1. Minimum voltage is -0.6V dc which may undershoot to -2.0V for pulses of less than 20 ns. Maximum output pin voltage is V<sub>CC</sub> + 0.75V dc which may overshoot to +7.0V for pulses of less than 20 ns.

## Operating Modes

Mode \ Pin	$\overline{CE}$	$\overline{OE}$	$\overline{PGM}$	A <sub>i</sub>	V <sub>PP</sub>	Outputs
Read	V <sub>IL</sub>	V <sub>IL</sub>	X <sup>(1)</sup>	A <sub>i</sub>	X	D <sub>OUT</sub>
Output Disable	X	V <sub>IH</sub>	X	X	X	High Z
Standby	V <sub>IH</sub>	X	X	X	X <sup>(5)</sup>	High Z
Rapid Program <sup>(2)</sup>	V <sub>IL</sub>	V <sub>IH</sub>	V <sub>IL</sub>	A <sub>i</sub>	V <sub>PP</sub>	D <sub>IN</sub>
PGM Verify	V <sub>IL</sub>	V <sub>IL</sub>	V <sub>IH</sub>	A <sub>i</sub>	V <sub>PP</sub>	D <sub>OUT</sub>
PGM Inhibit	V <sub>IH</sub>	X	X	X	V <sub>PP</sub>	High Z
Product Identification <sup>(4)</sup>	V <sub>IL</sub>	V <sub>IL</sub>	X	A <sub>9</sub> = V <sub>H</sub> <sup>(3)</sup> A <sub>0</sub> = V <sub>IH</sub> or V <sub>IL</sub> A <sub>1</sub> - A <sub>14</sub> = V <sub>IL</sub>	V <sub>CC</sub>	Identification Code

Notes: 1. X can be V<sub>IL</sub> or V<sub>IH</sub>.

2. Refer to Programming characteristics.

3. V<sub>H</sub> = 12.0 ± 0.5V.

4. Two identifier words may be selected. All A<sub>i</sub> inputs are held low (V<sub>IL</sub>), except A<sub>9</sub> which is set to V<sub>H</sub> and A<sub>0</sub> which is toggled low (V<sub>IL</sub>) to select the Manufacturer's Identification word and high (V<sub>IH</sub>) to select the Device Code word.

5. Standby V<sub>CC</sub> current (I<sub>SB</sub>) is specified with V<sub>PP</sub> = V<sub>CC</sub>. V<sub>CC</sub> > V<sub>PP</sub> will cause a slight increase in I<sub>SB</sub>.

## DC and AC Operating Conditions for Read Operation

		AT27C516				
		-45	-55	-70	-85	-10
Operating Temperature (Case)	Com.	0°C - 70°C	0°C - 70°C	0°C - 70°C	0°C - 70°C	0°C - 70°C
	Ind.	-40°C - 85°C	-40°C - 85°C	-40°C - 85°C	-40°C - 85°C	-40°C - 85°C
V <sub>CC</sub> Power Supply		5V ± 10%	5V ± 10%	5V ± 10%	5V ± 10%	5V ± 10%

## DC and Operating Characteristics for Read Operation

Symbol	Parameter	Condition	Min	Max	Units
I <sub>LI</sub>	Input Load Current	V <sub>IN</sub> = 0V to V <sub>CC</sub>		± 1	μA
I <sub>LO</sub>	Output Leakage Current	V <sub>OUT</sub> = 0V to V <sub>CC</sub>		± 5	μA
I <sub>PP1</sub> <sup>(2)</sup>	V <sub>PP</sub> <sup>(1)</sup> Read/Standby Current	V <sub>PP</sub> = V <sub>CC</sub>		10	μA
I <sub>SB</sub>	V <sub>CC</sub> <sup>(1)</sup> Standby Current	I <sub>SB1</sub> (CMOS), $\overline{CE} = V_{CC} \pm 0.3V$		100	μA
		I <sub>SB2</sub> (TTL), $\overline{CE} = 2.0$ to V <sub>CC</sub> + 0.5V		1	mA
I <sub>CC</sub>	V <sub>CC</sub> Active Current	f = 5 MHz, I <sub>OUT</sub> = 0 mA, $\overline{CE} = V_{IL}$		30	mA
V <sub>IL</sub>	Input Low Voltage		-0.6	0.8	V
V <sub>IH</sub>	Input High Voltage		2.0	V <sub>CC</sub> + 0.5	V
V <sub>OL</sub>	Output Low Voltage	I <sub>OL</sub> = 2.1 mA		0.4	V
V <sub>OH</sub>	Output High Voltage	I <sub>OH</sub> = -400 μA	2.4		V

Notes: 1. V<sub>CC</sub> must be applied simultaneously or before V<sub>PP</sub>, and removed simultaneously or after V<sub>PP</sub>.  
 2. V<sub>PP</sub> may be connected directly to V<sub>CC</sub>, except during programming. The supply current would then be the sum of I<sub>CC</sub> and I<sub>PP</sub>.

## AC Characteristics for Read Operation

			AT27C516						Units				
			-45		-55		-70			-85		-10	
Symbol	Parameter	Condition	Min	Max	Min	Max	Min	Max		Min	Max	Min	Max
t <sub>ACC</sub> <sup>(3)</sup>	Address to Output Delay	$\overline{CE} = \overline{OE} = V_{IL}$		45		55		70		85		100	ns
t <sub>CE</sub> <sup>(2)</sup>	$\overline{CE}$ to Output Delay	$\overline{OE} = V_{IL}$		45		55		70		85		100	ns
t <sub>OE</sub> <sup>(2, 3)</sup>	$\overline{OE}$ to Output Delay	$\overline{CE} = V_{IL}$		20		25		25		30		30	ns
t <sub>DF</sub> <sup>(4, 5)</sup>	$\overline{OE}$ or $\overline{CE}$ High to Output Float, whichever occurred first			20		25		25		30		30	ns
t <sub>OH</sub>	Output Hold from Address, $\overline{CE}$ or $\overline{OE}$ , whichever occurred first		7		7		7		0		0		ns

Notes: 2, 3, 4, 5. - see AC Waveforms for Read Operation.

## AC Waveforms for Read Operation <sup>(1)</sup>

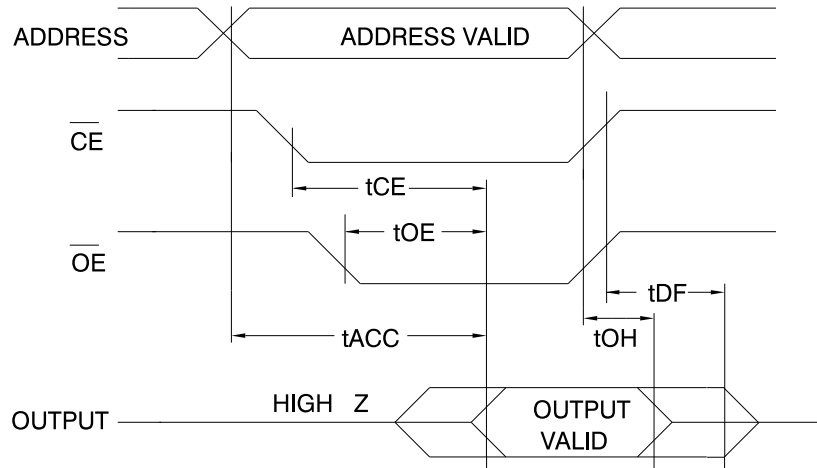

- Notes:
1. Timing measurement reference level is 1.5V for -45 and -55 devices. Input AC drive levels are  $V_{IL} = 0.0V$  and  $V_{IH} = 3.0V$ . Timing measurement reference levels for all other speed grades are  $V_{OL} = 0.8V$  and  $V_{OH} = 2.0V$ . Input AC drive levels are  $V_{IL} = 0.45V$  and  $V_{IH} = 2.4V$ .
  2.  $\overline{OE}$  may be delayed up to  $t_{CE} - t_{OE}$  after the falling edge of  $\overline{CE}$  without impact on  $t_{CE}$ .
  3.  $\overline{OE}$  may be delayed up to  $t_{ACC} - t_{OE}$  after the address is valid without impact on  $t_{ACC}$ .
  4. This parameter is only sampled and is not 100% tested.
  5. Output float is defined as the point when data is no longer driven.

## Input Test Waveforms and Measurement Levels

For -45, -55, and -70 Devices Only:

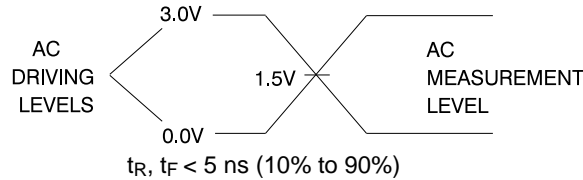

For -85 and -10 Devices Only:

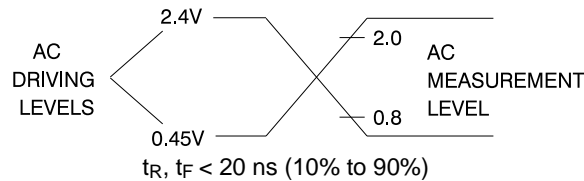

## Output Test Load

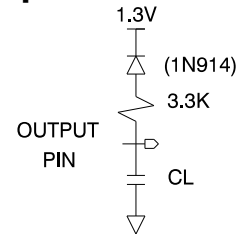

Note:  $CL = 100 \text{ pF}$  including jig capacitance except -45, -55 and -70 devices, where  $CL = 30 \text{ pF}$ .

## Pin Capacitance $(f = 1 \text{ MHz } T = 25^\circ\text{C})$ <sup>(1)</sup>

	Typ	Max	Units	Conditions
$C_{IN}$	4	10	pF	$V_{IN} = 0V$
$C_{OUT}$	8	12	pF	$V_{OUT} = 0V$

Note: 1. Typical values for nominal supply voltage. This parameter is only sampled and is not 100% tested.

## Programming Waveforms <sup>(1)</sup>

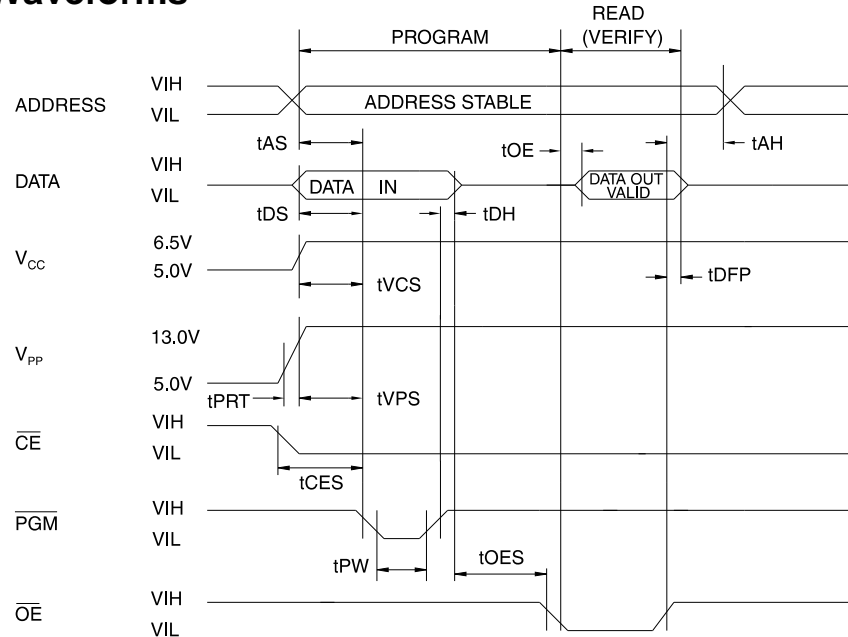

- Notes:
1. The Input Timing Reference is 0.8V for V<sub>IL</sub> and 2.0V for V<sub>IH</sub>.
  2. t<sub>OE</sub> and t<sub>DFP</sub> are characteristics of the device but must be accommodated by the programmer.
  3. When programming the AT27C516 a 0.1 μF capacitor is required across V<sub>PP</sub> and ground to suppress spurious voltage transients.

## DC Programming Characteristics

T<sub>A</sub> = 25 ± 5°C, V<sub>CC</sub> = 6.5 ± 0.25V, V<sub>PP</sub> = 13.0 ± 0.25V

Symbol	Parameter	Test Conditions	Limits		Units
			Min	Max	
I <sub>LI</sub>	Input Load Current	V <sub>IN</sub> = V <sub>IL</sub> , V <sub>IH</sub>		±10	μA
V <sub>IL</sub>	Input Low Level		-0.6	0.8	V
V <sub>IH</sub>	Input High Level		2.0	V <sub>CC</sub> + 0.1	V
V <sub>OL</sub>	Output Low Voltage	I <sub>OL</sub> = 2.1 mA		0.4	V
V <sub>OH</sub>	Output High Voltage	I <sub>OH</sub> = -400 μA	2.4		V
I <sub>CC2</sub>	V <sub>CC</sub> Supply Current (Program and Verify)			50	mA
I <sub>PP2</sub>	V <sub>PP</sub> Supply Current	$\overline{CE} = \overline{PGM} = V_{IL}$		30	mA
V <sub>ID</sub>	A9 Product Identification Voltage		11.5	12.5	V

## AC Programming Characteristics

$T_A = 25 \pm 5^\circ\text{C}$ ,  $V_{CC} = 6.5 \pm 0.25\text{V}$ ,  $V_{PP} = 13.0 \pm 0.25\text{V}$

Sym- bol	Parameter	Test Conditions* (1)	Limit		Units
			Min	Max	
t <sub>AS</sub>	Address Setup Time		2		μs
t <sub>CES</sub>	$\overline{\text{CE}}$ Setup Time		2		μs
t <sub>OES</sub>	$\overline{\text{OE}}$ Setup Time		2		μs
t <sub>DS</sub>	Data Setup Time		2		μs
t <sub>AH</sub>	Address Hold Time		0		μs
t <sub>DH</sub>	Data Hold Time		2		μs
t <sub>DFP</sub>	$\overline{\text{OE}}$ High to Output Float Delay (2)		0	130	ns
t <sub>VPS</sub>	V <sub>PP</sub> Setup Time		2		μs
t <sub>VCS</sub>	V <sub>CC</sub> Setup Time		2		μs
t <sub>PW</sub>	PGM Program Pulse Width (3)		47.5	52.5	μs
t <sub>OE</sub>	Data Valid from $\overline{\text{OE}}$			150	ns
t <sub>PRT</sub>	V <sub>PP</sub> Pulse Rise Time During Programming		50		ns

**\*AC Conditions of Test:**

Input Rise and Fall Times (10% to 90%).....20 ns  
 Input Pulse Levels.....0.45V to 2.4V  
 Input Timing Reference Level.....0.8V to 2.0V  
 Output Timing Reference Level.....0.8V to 2.0V

- Notes: 1. V<sub>CC</sub> must be applied simultaneously or before V<sub>PP</sub> and removed simultaneously or after V<sub>PP</sub>.  
 2. This parameter is only sampled and is not 100% tested. Output Float is defined as the point where data is no longer driven — see timing diagram.  
 3. Program Pulse width tolerance is 50 μsec ± 5%.

## Atmel's 27C516 Integrated Product Identification Code

Codes	Pins										Hex Data
	A0	015-08	O7	O6	O5	O4	O3	O2	O1	O0	
Manufacturer	0	0	0	0	0	1	1	1	1	0	001E
Device Type	1	0	1	1	1	1	0	0	1	0	00F2

## Rapid Programming Algorithm

A 50 μs  $\overline{\text{PGM}}$  pulse width is used to program. The address is set to the first location. V<sub>CC</sub> is raised to 6.5V and V<sub>PP</sub> is raised to 13.0V. Each address is first programmed with one 50 μs  $\overline{\text{PGM}}$  pulse without verification. Then a verification / reprogramming loop is executed for each address. In the event a word fails to pass verification, up to 10 successive 50 μs pulses are applied with a verification after each pulse. If the word fails to verify after 10 pulses have been applied, the part is considered failed. After the word verifies properly, the next address is selected until all have been checked. V<sub>PP</sub> is then lowered to 5.0V and V<sub>CC</sub> to 5.0V. All words are read again and compared with the original data to determine if the device passes or fails.

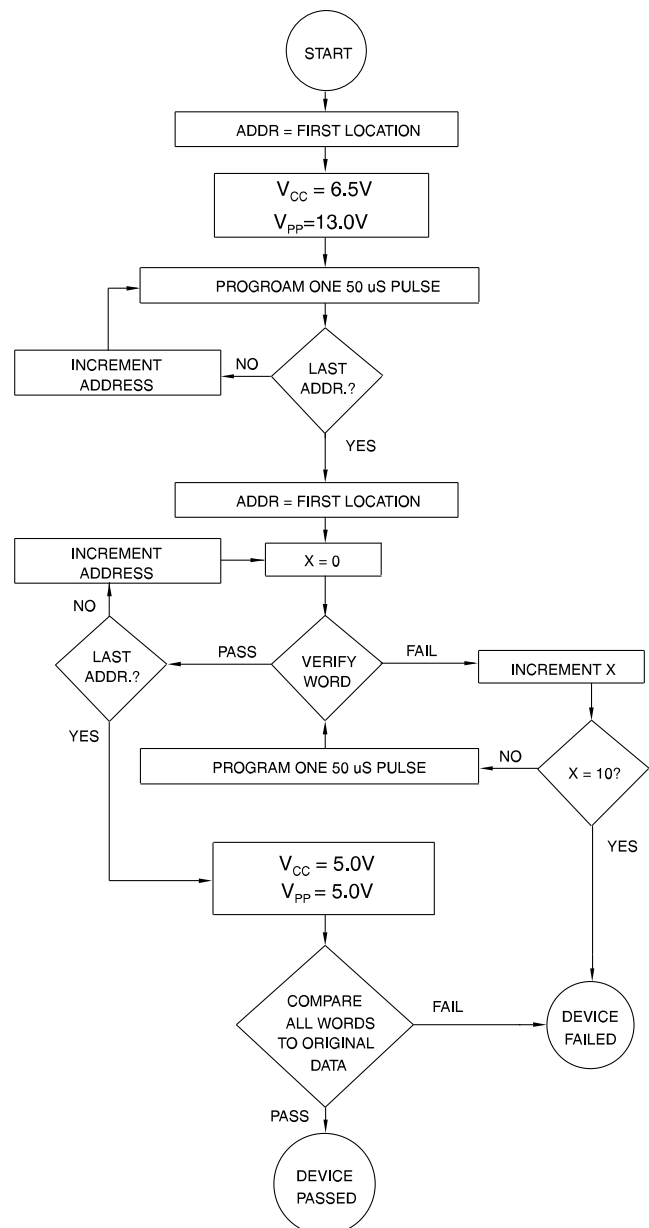

## Ordering Information

t <sub>ACC</sub> (ns)	I <sub>CC</sub> (mA)		Ordering Code	Package	Operation Range
	Active	Standby			
45	30	0.1	AT27C516-45JC AT27C516-45VC	44J 40V	Commercial (0°C to 70°C)
	30	0.1	AT27C516-45JI AT27C516-45VI	44J 40V	Industrial (-40°C to 85°C)
55	30	0.1	AT27C516-55JC AT27C516-55VC	44J 40V	Commercial (0°C to 70°C)
	30	0.1	AT27C516-55JI AT27C516-55VI	44J 40V	Industrial (-40°C to 85°C)
70	30	0.1	AT27C516-70JC AT27C516-70VC	44J 40V	Commercial (0°C to 70°C)
	30	0.1	AT27C516-70JI AT27C516-70VI	44J 40V	Industrial (-40°C to 85°C)
85	30	0.1	AT27C516-85JC AT27C516-85VC	44J 40V	Commercial (0°C to 70°C)
	30	0.1	AT27C516-85JI AT27C516-85VI	44J 40V	Industrial (-40°C to 85°C)
100	30	0.1	AT27C516-10JC AT27C516-10VC	44J 40V	Commercial (0°C to 70°C)
	30	0.1	AT27C516-10JI AT27C516-10VI	44J 40V	Industrial (-40°C to 85°C)

Package Type	
<b>44J</b>	44 Lead, Plastic J-Leaded Chip Carrier (PLCC)
<b>40V</b>	40 Lead, Plastic Thin Small Outline Package (TSOP) (10mm x 14mm)