

# DATA SHEET

**CBT3253**

Dual 1-of-4 FET multiplexer/demultiplexer

Product data

2002 Nov 04

## Dual 1-of-4 FET multiplexer/demultiplexer

CBT3253

## FEATURES

- 5  $\Omega$  switch connection between two ports
- TTL-compatible input levels
- Minimal propagation delay through the switch
- ESD protection exceeds 2000 V HBM per JESD22-A114, 200 V MM per JESD22-A115 and 1000 V CDM per JESD22-C101
- Latch-up testing is done to JESDEC Standard JESD78 which exceeds 100 mA

## DESCRIPTION

The CBT3253 is a dual 1-of-4 high-speed TTL-compatible FET multiplexer/demultiplexer. The low on resistance of the switch allows inputs to be connected to outputs without adding propagation delay or generating additional ground bounce noise.

$1\overline{OE}$ ,  $2\overline{OE}$ , S0, and S1 select the appropriate B output for the A-input data.

The CBT3251 is characterized for operation from  $-40$  to  $+85^{\circ}\text{C}$ .

## PIN CONFIGURATION

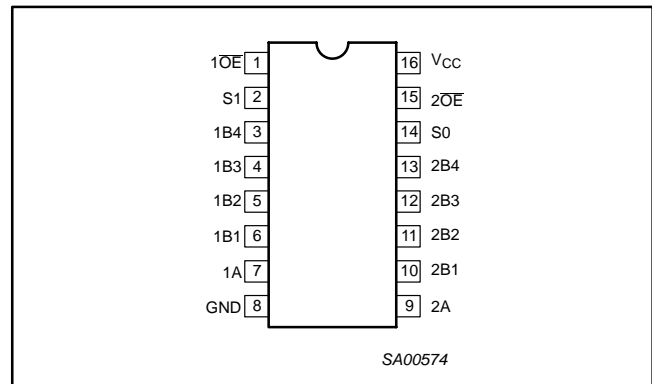

## PIN DESCRIPTION

PIN NUMBER	SYMBOL	NAME AND FUNCTION
1	$1\overline{OE}$	Output enable
2	S1	Select-control input
3, 4, 5, 6	1B[1–4]	B outputs
7	1A	A input
8	GND	Ground (0 V)
9	2A	A input
10, 11, 12, 13	2B[1–4]	Select-control input
14	S0	Select-control input
15	$2\overline{OE}$	Output enable
16	$V_{CC}$	Positive supply voltage

## ORDERING INFORMATION

PACKAGES	TEMPERATURE RANGE	ORDER CODE	TOPSIDE MARK	DWG NUMBER
16-pin plastic SO	$-40$ to $85^{\circ}\text{C}$	CBT3253D	CBT3253D	SOT109-1
16-pin plastic SSOP	$-40$ to $85^{\circ}\text{C}$	CBT3253DB	CT3253	SOT338-1
16-pin plastic SSOP (QSOP)	$-40$ to $85^{\circ}\text{C}$	CBT3253DS	CBT3253	SOT519-1
16-pin plastic TSSOP	$-40$ to $85^{\circ}\text{C}$	CBT3253PW	CBT3253	SOT403-1

Standard packing quantities and other packaging data is available at [www.philipslogic.com/packaging](http://www.philipslogic.com/packaging).

# Dual 1-of-4 FET multiplexer/demultiplexer

CBT3253

## LOGIC DIAGRAM (positive logic)

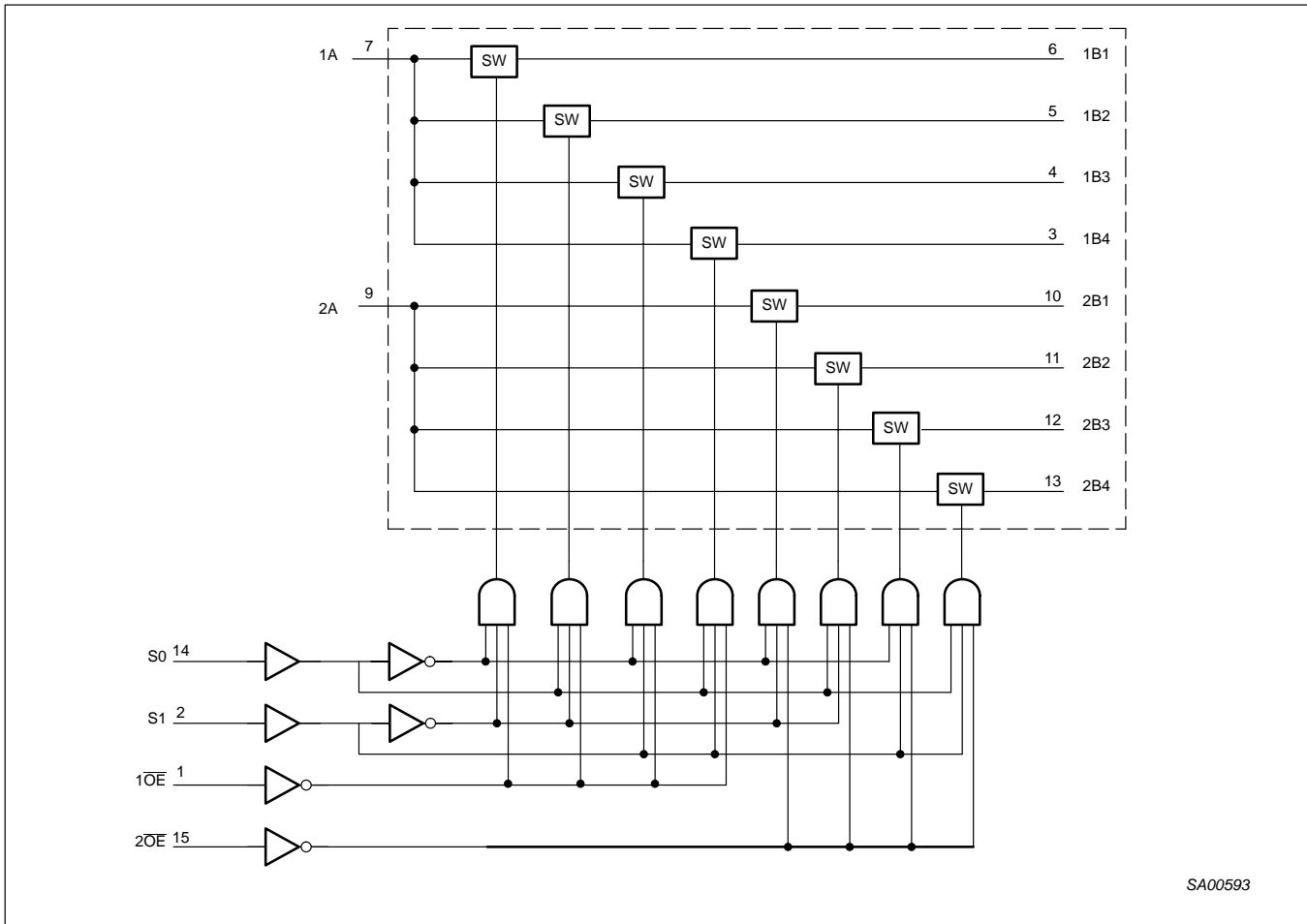

## FUNCTION TABLE

INPUTS				FUNCTION
OE1	OE2	S1	S0	
H	X	X	X	Disconnect 1A
X	H	X	X	Disconnect 2A
L	L	L	L	1A to 1B1 and 2A to 2B1
L	L	L	H	1A to 1B2 and 2A to 2B2
L	L	H	L	1A to 1B3 and 2A to 2B3
L	L	H	H	1A to 1B4 and 2A to 2B4

## Dual 1-of-4 FET multiplexer/demultiplexer

CBT3253

ABSOLUTE MAXIMUM RATINGS<sup>1</sup>

SYMBOL	PARAMETER	CONDITIONS	RATING	UNIT
$V_{CC}$	DC supply voltage		-0.5 to +7.0	V
$V_I$	DC input voltage <sup>2</sup>		-0.5 to +7.0	V
	Continuous channel current		128	mA
$I_K$	Input clamp current	$V_{I/O} < 0$	-50	mA
$T_{stg}$	Storage temperature range		-65 to +150	°C

## NOTES:

- Stresses beyond those listed may cause permanent damage to the device. These are stress ratings only and functional operation of the device at these or any other conditions beyond those indicated under "recommended operating conditions" is not implied. Exposure to absolute-maximum-rated conditions for extended periods may affect device reliability.
- The input and output negative-voltage ratings may be exceeded if the input and output clamp-current ratings are observed.

## RECOMMENDED OPERATING CONDITIONS

SYMBOL	PARAMETER	LIMITS		UNIT
		MIN	MAX	
$V_{CC}$	DC supply voltage	4.5	5.5	V
$V_{IH}$	High-level input voltage	2	—	V
$V_{IL}$	Low-level Input voltage	—	0.8	V
$T_{amb}$	Operating free-air temperature range	-40	+85	°C

## NOTE:

- All unused control inputs of the device must be held at  $V_{CC}$  or GND to ensure proper device operation.

## DC ELECTRICAL CHARACTERISTICS

SYMBOL	PARAMETER	TEST CONDITIONS	LIMITS			UNIT	
			$T_{amb} = -40 \text{ to } +85 \text{ } ^\circ\text{C}$				
			MIN	TYP <sup>1</sup>	MAX		
$V_{IK}$	Input clamp voltage	$V_{CC} = 4.5 \text{ V}; I_I = -18 \text{ mA}$	—	—	-1.2	V	
$V_P$	Pass voltage	$V_I = V_{CC} = 5.5 \text{ V}; I/O = -100 \text{ } \mu\text{A}$	3.4	3.6	3.9	V	
$I_I$	Input leakage current	$V_{CC} = 5 \text{ V}; V_I = 5.5 \text{ or GND}$	—	—	$\pm 1$	$\mu\text{A}$	
$I_{CC}$	Quiescent supply current	$V_{CC} = 5.5 \text{ V}; I_O = 0, V_I = V_{CC} \text{ or GND}$	—	—	3	$\mu\text{A}$	
$\Delta I_{CC}$	Control inputs <sup>2</sup>	$V_{CC} = 5.5 \text{ V}$ , one input at 3.4 V, other inputs at $V_{CC}$ or GND	—	—	2.5	mA	
$C_I$	Control pins	$V_I = 3 \text{ V or } 0$	—	4.5	—	pF	
$C_{IO(OFF)}$	Power-off leakage current	A port	—	23.5	—	pF	
		B port	—	6.5	—		
$r_{on}^3$	On-resistance	$V_{CC} = 4.5 \text{ V}$	$V_I = 0 \text{ V}; I_I = 64 \text{ mA}$	—	5	7	$\Omega$
			$V_I = 0 \text{ V}; I_I = 30 \text{ mA}$	—	5	7	
			$V_I = 2.4 \text{ V}; I_I = -15 \text{ mA}$	—	10	15	

## NOTES:

- All typical values are at  $V_{CC} = 5 \text{ V}$ ,  $T_{amb} = 25 \text{ } ^\circ\text{C}$ .
- This is the increase in supply current for each input that is at the specified TTL voltage level rather than  $V_{CC}$  or GND
- Measured by the voltage drop between the A and the B terminals at the indicated current through the switch. On-state resistance is determined by the lowest voltage of the two (A or B) terminals.

## Dual 1-of-4 FET multiplexer/demultiplexer

CBT3253

**AC CHARACTERISTICS** $T_{amb} = -40$  to  $+85$  °C;  $C_L = 50$  pF

SYMBOL	PARAMETER	FROM (INPUT)	TO (OUTPUT)	LIMITS		UNIT
				$V_{CC} = +5.0 V \pm 0.5 V$		
				MIN	MAX	
$t_{pd}$	Propagation delay <sup>1</sup>	A or B	B or A	—	0.25	ns
		S	A or B	1.2	6.2	
$t_{en}$	Output enable time to High and Low level	S	A or B	1.3	6.3	ns
		$\overline{OE}$		1.4	6.4	
$t_{dis}$	Output disable time from High and Low level	S	A or B	1.1	7.2	ns
		$\overline{OE}$		1.0	7	

**NOTE:**

1. The propagation delay is the calculated RC time constant of the typical on-state resistance of the switch and the specified load capacitance, when driven by an ideal voltage source (zero output impedance).

# Dual 1-of-4 FET multiplexer/demultiplexer

CBT3253

## AC WAVEFORMS

$V_M = 1.5\text{ V}$ ,  $V_{IN} = \text{GND to } 3.0\text{ V}$

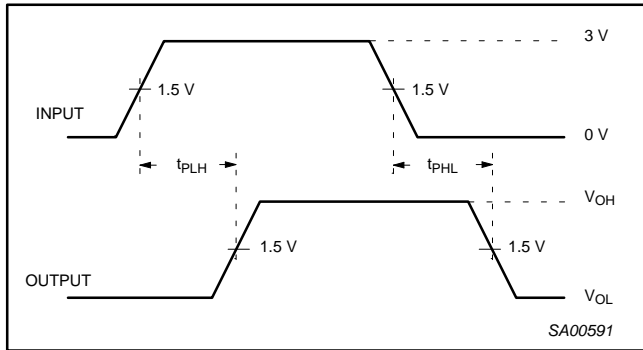

Waveform 1. Pulse duration

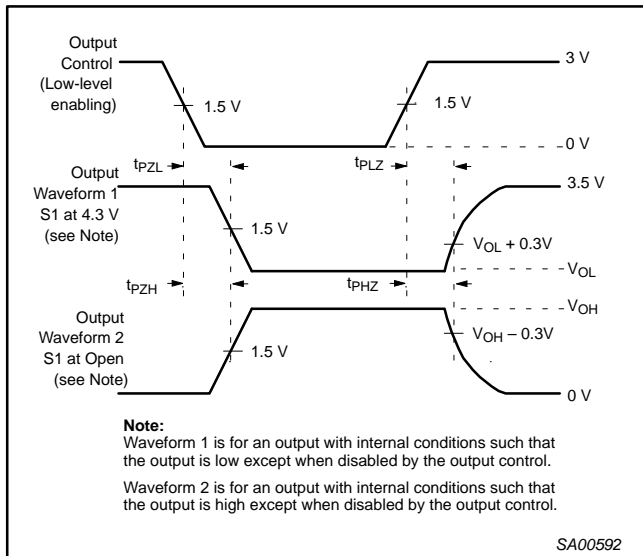

Waveform 2. 3-State Output Enable and Disable Times

### NOTES:

1.  $t_{PLZ}$  and  $t_{PHZ}$  are the same as  $t_{dis}$ .
2.  $t_{PZL}$  and  $t_{PZH}$  are the same as  $t_{en}$ .
3.  $t_{PLH}$  and  $t_{PHL}$  are the same as  $t_{pd}$ .

## TEST CIRCUIT AND WAVEFORMS

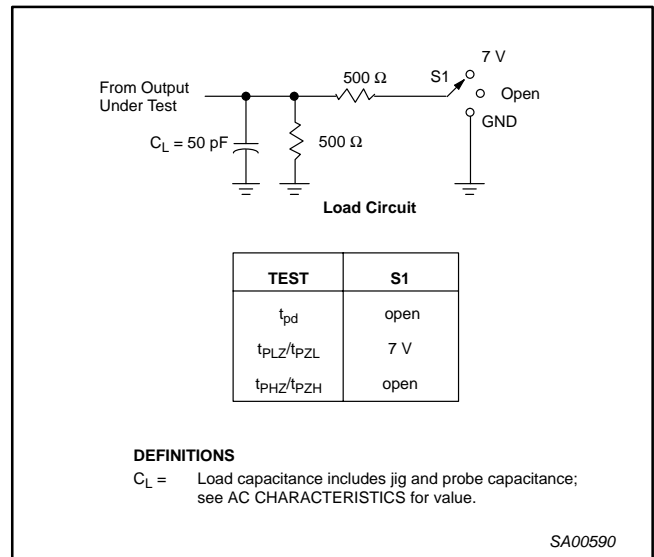

### NOTES:

1. All input pulses are supplied by generators having the following characteristics:  $PRR \leq 10\text{ MHz}$ ,  $Z_O = 50\ \Omega$ ,  $t_r \leq 2.5\text{ ns}$ ,  $t_f \leq 2.5\text{ ns}$ .
2. The outputs are measured one at a time with one transition per measurement.

# Dual 1-of-4 FET multiplexer/demultiplexer

CBT3253

SO16: plastic small outline package; 16 leads; body width 3.9 mm

SOT109-1

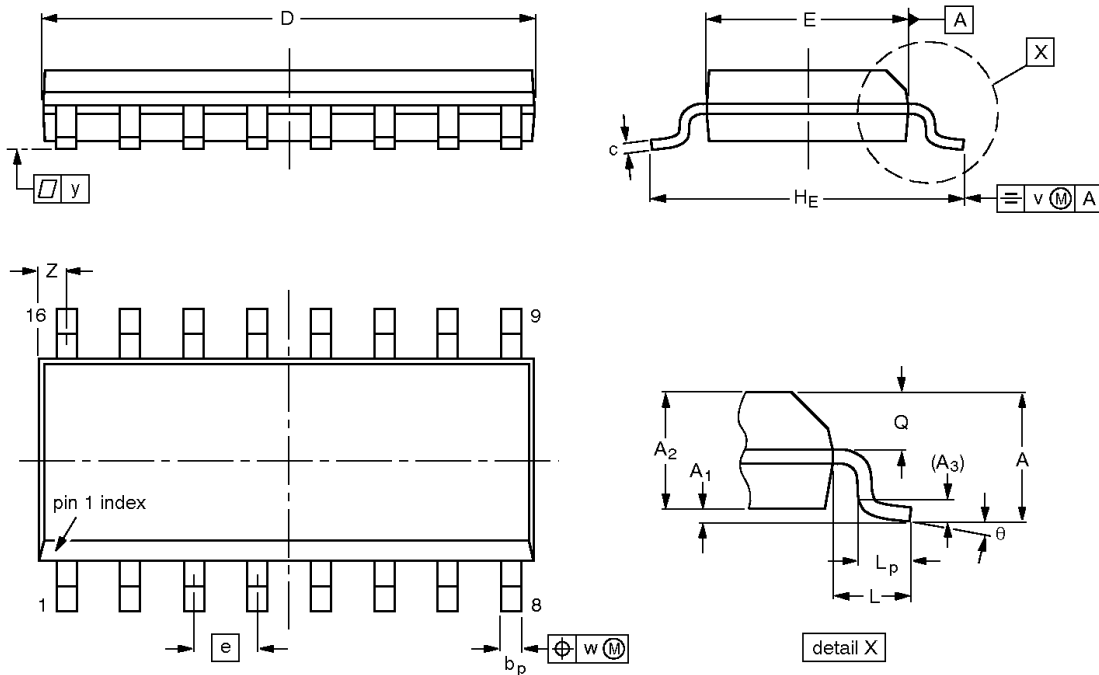

**DIMENSIONS (inch dimensions are derived from the original mm dimensions)**

UNIT	A max.	A <sub>1</sub>	A <sub>2</sub>	A <sub>3</sub>	b <sub>p</sub>	c	D <sup>(1)</sup>	E <sup>(1)</sup>	e	H <sub>E</sub>	L	L <sub>p</sub>	Q	v	w	y	Z <sup>(1)</sup>	θ
mm	1.75	0.25 0.10	1.45 1.25	0.25	0.49 0.36	0.25 0.19	10.0 9.8	4.0 3.8	1.27	6.2 5.8	1.05	1.0 0.4	0.7 0.6	0.25	0.25	0.1	0.7 0.3	8° 0°
inches	0.069	0.010 0.004	0.057 0.049	0.01	0.019 0.014	0.0100 0.0075	0.39 0.38	0.16 0.15	0.050	0.244 0.228	0.041	0.039 0.016	0.028 0.020	0.01	0.01	0.004	0.028 0.012	

**Note**

1. Plastic or metal protrusions of 0.15 mm maximum per side are not included.

OUTLINE VERSION	REFERENCES				EUROPEAN PROJECTION	ISSUE DATE
	IEC	JEDEC	EIAJ			
SOT109-1	076E07	MS-012				97-05-22 99-12-27

# Dual 1-of-4 FET multiplexer/demultiplexer

CBT3253

**SSOP16:** plastic shrink small outline package; 16 leads; body width 5.3 mm

**SOT338-1**

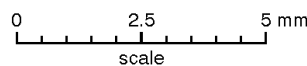
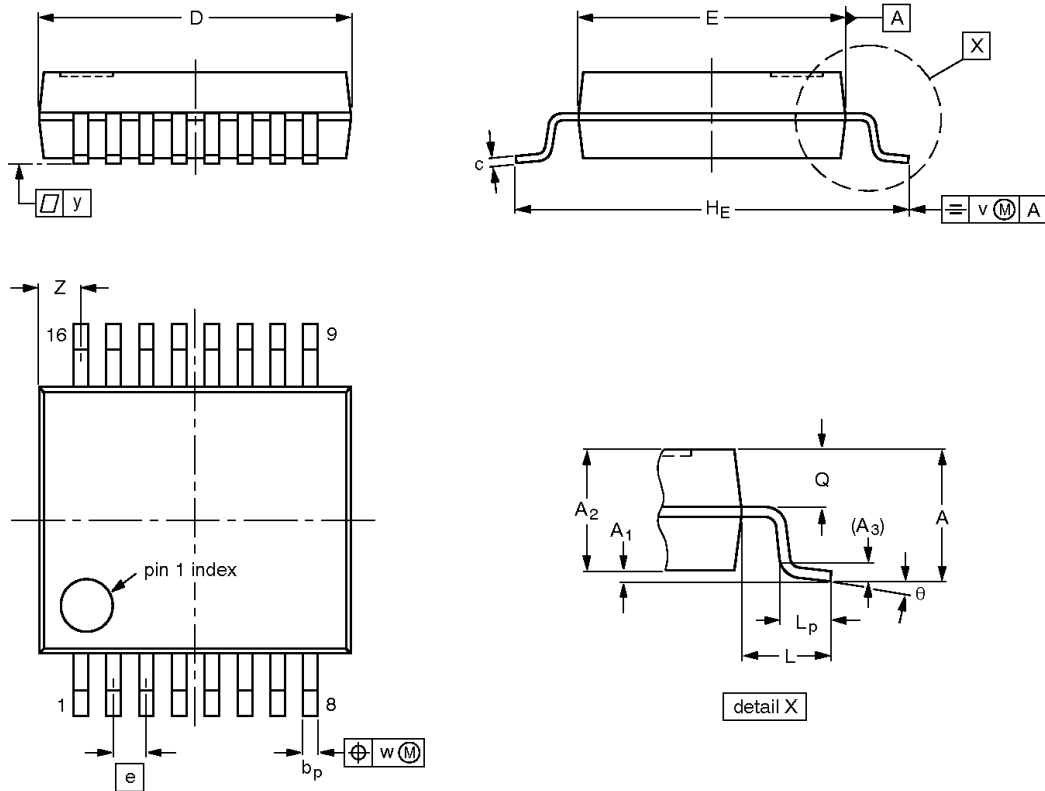

**DIMENSIONS (mm are the original dimensions)**

UNIT	A max.	A <sub>1</sub>	A <sub>2</sub>	A <sub>3</sub>	b <sub>p</sub>	c	D <sup>(1)</sup>	E <sup>(1)</sup>	e	H <sub>E</sub>	L	L <sub>p</sub>	Q	v	w	y	Z <sup>(1)</sup>	θ
mm	2.0	0.21 0.05	1.80 1.65	0.25	0.38 0.25	0.20 0.09	6.4 6.0	5.4 5.2	0.65	7.9 7.6	1.25	1.03 0.63	0.9 0.7	0.2	0.13	0.1	1.00 0.55	8° 0°

**Note**

1. Plastic or metal protrusions of 0.25 mm maximum per side are not included.

OUTLINE VERSION	REFERENCES				EUROPEAN PROJECTION	ISSUE DATE
	IEC	JEDEC	EIAJ			
SOT338-1		MO-150				95-02-04 99-12-27



# Dual 1-of-4 FET multiplexer/demultiplexer

CBT3253

**SSOP16:** plastic shrink small outline package; 16 leads;  
body width 3.9 mm; lead pitch 0.635 mm

SOT519-1

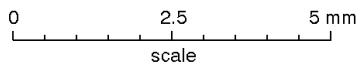
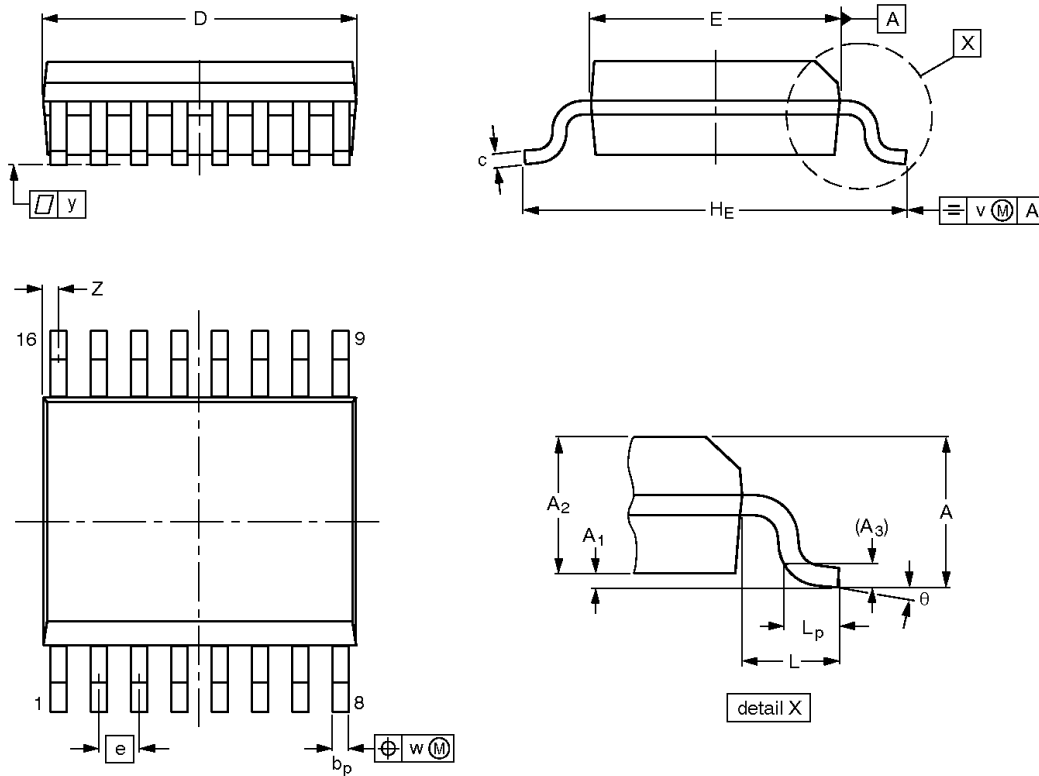

**DIMENSIONS (mm are the original dimensions)**

UNIT	A max.	A <sub>1</sub>	A <sub>2</sub>	A <sub>3</sub>	b <sub>p</sub>	c	D <sup>(1)</sup>	E <sup>(1)</sup>	e	H <sub>E</sub>	L	L <sub>p</sub>	v	w	y	Z <sup>(1)</sup>	θ
mm	1.73	0.25 0.10	1.55 1.40	0.25	0.31 0.20	0.25 0.18	5.0 4.8	4.0 3.8	0.635	6.2 5.8	1.0	0.89 0.41	0.2	0.18	0.09	0.18 0.05	8° 0°

**Note**

1. Plastic or metal protrusions of 0.20 mm maximum per side are not included.

OUTLINE VERSION	REFERENCES				EUROPEAN PROJECTION	ISSUE DATE
	IEC	JEDEC	EIAJ			
SOT519-1						99-05-04

# Dual 1-of-4 FET multiplexer/demultiplexer

CBT3253

TSSOP16: plastic thin shrink small outline package; 16 leads; body width 4.4 mm

SOT403-1

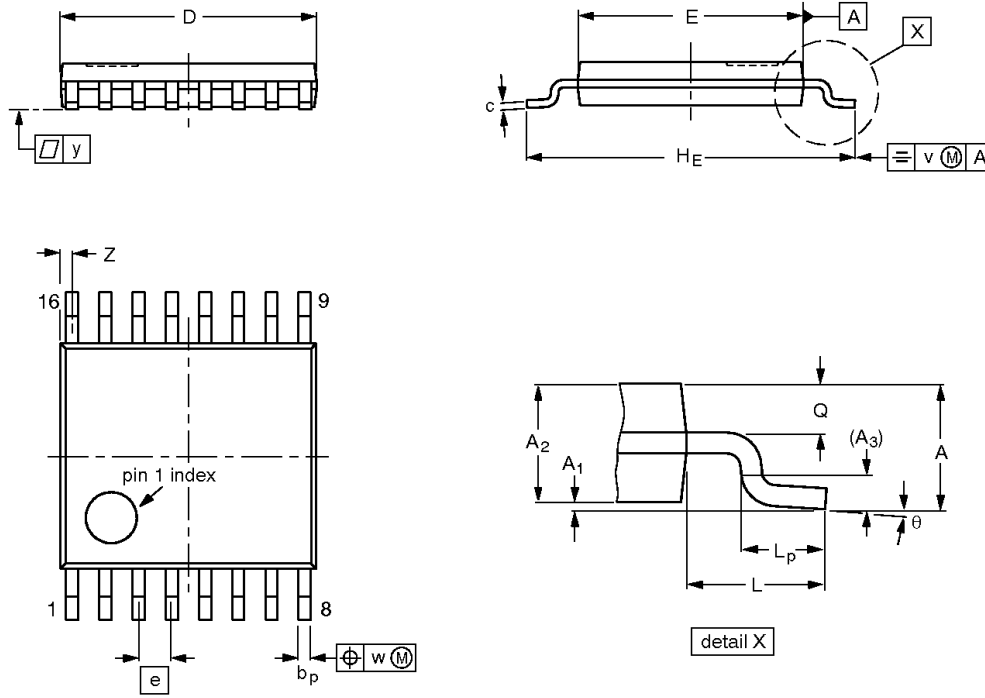

**DIMENSIONS (mm are the original dimensions)**

UNIT	A max.	A <sub>1</sub>	A <sub>2</sub>	A <sub>3</sub>	b <sub>p</sub>	c	D <sup>(1)</sup>	E <sup>(2)</sup>	e	H <sub>E</sub>	L	L <sub>p</sub>	Q	v	w	y	Z <sup>(1)</sup>	θ
mm	1.10	0.15 0.05	0.95 0.80	0.25	0.30 0.19	0.2 0.1	5.1 4.9	4.5 4.3	0.65	6.6 6.2	1.0	0.75 0.50	0.4 0.3	0.2	0.13	0.1	0.40 0.06	8° 0°

**Notes**

1. Plastic or metal protrusions of 0.15 mm maximum per side are not included.
2. Plastic interlead protrusions of 0.25 mm maximum per side are not included.

OUTLINE VERSION	REFERENCES				EUROPEAN PROJECTION	ISSUE DATE
	IEC	JEDEC	EIAJ			
SOT403-1		MO-153				-95-04-04 99-12-27

## Dual 1-of-4 FET multiplexer/demultiplexer

CBT3253

**REVISION HISTORY**

Rev	Date	Description
_1	2002 Nov 04	Product data (9397 750 10664); initial version Engineering Change Notice: 853-2389 29065 (2002 Oct 15)

## Dual 1-of-4 FET multiplexer/demultiplexer

CBT3253

## Data sheet status

Level	Data sheet status <sup>[1]</sup>	Product status <sup>[2] [3]</sup>	Definitions
I	Objective data	Development	This data sheet contains data from the objective specification for product development. Philips Semiconductors reserves the right to change the specification in any manner without notice.
II	Preliminary data	Qualification	This data sheet contains data from the preliminary specification. Supplementary data will be published at a later date. Philips Semiconductors reserves the right to change the specification without notice, in order to improve the design and supply the best possible product.
III	Product data	Production	This data sheet contains data from the product specification. Philips Semiconductors reserves the right to make changes at any time in order to improve the design, manufacturing and supply. Relevant changes will be communicated via a Customer Product/Process Change Notification (CPCN).

[1] Please consult the most recently issued data sheet before initiating or completing a design.

[2] The product status of the device(s) described in this data sheet may have changed since this data sheet was published. The latest information is available on the Internet at URL <http://www.semiconductors.philips.com>.

[3] For data sheets describing multiple type numbers, the highest-level product status determines the data sheet status.

## Definitions

**Short-form specification** — The data in a short-form specification is extracted from a full data sheet with the same type number and title. For detailed information see the relevant data sheet or data handbook.

**Limiting values definition** — Limiting values given are in accordance with the Absolute Maximum Rating System (IEC 60134). Stress above one or more of the limiting values may cause permanent damage to the device. These are stress ratings only and operation of the device at these or at any other conditions above those given in the Characteristics sections of the specification is not implied. Exposure to limiting values for extended periods may affect device reliability.

**Application information** — Applications that are described herein for any of these products are for illustrative purposes only. Philips Semiconductors make no representation or warranty that such applications will be suitable for the specified use without further testing or modification.

## Disclaimers

**Life support** — These products are not designed for use in life support appliances, devices, or systems where malfunction of these products can reasonably be expected to result in personal injury. Philips Semiconductors customers using or selling these products for use in such applications do so at their own risk and agree to fully indemnify Philips Semiconductors for any damages resulting from such application.

**Right to make changes** — Philips Semiconductors reserves the right to make changes in the products—including circuits, standard cells, and/or software—described or contained herein in order to improve design and/or performance. When the product is in full production (status 'Production'), relevant changes will be communicated via a Customer Product/Process Change Notification (CPCN). Philips Semiconductors assumes no responsibility or liability for the use of any of these products, conveys no license or title under any patent, copyright, or mask work right to these products, and makes no representations or warranties that these products are free from patent, copyright, or mask work right infringement, unless otherwise specified.

## Contact information

For additional information please visit  
<http://www.semiconductors.philips.com>. Fax: +31 40 27 24825

© Koninklijke Philips Electronics N.V. 2002  
 All rights reserved. Printed in U.S.A.

Date of release: 11-02

For sales offices addresses send e-mail to:  
[sales.addresses@www.semiconductors.philips.com](mailto:sales.addresses@www.semiconductors.philips.com)

Document order number: 9397 750 10664

*Let's make things better.*