

# HD153129

## Color Palette with Triple 6-bit DA Converter

The HD153129P is a high-speed, high-density, low-power color palette with triple 6-bit DA converter.

Manufactured using a Hi-BiCMOS process, it realizes advanced DA conversion, high-speed SRAM and high-speed logic all on a single LSI chip with its color palette, advanced functions, small size and low cost, the HD153129P is an essential component for advanced graphics systems.

### Features

- Displays 256 colors simultaneously from a total of 262,144 possible colors.
- Three 6-bit DA converters for RGB video output on a single chip
- Pixel mask function for display control
- Compatible with personal system/2
- Dot rate maximum of 50/65 MHz
- TTL compatible I/O levels
- 28-pin plastic DIP

### Ordering Information

Type No.	Max. Operating Freq.	Package
HD153129P	50 MHz	600 mil 28 pin
HD153129P-65	65 MHz	plastic DIP (DP-28)

Note: Personal system/2 is a registered trademark of IBM.

### Pin Arrangement

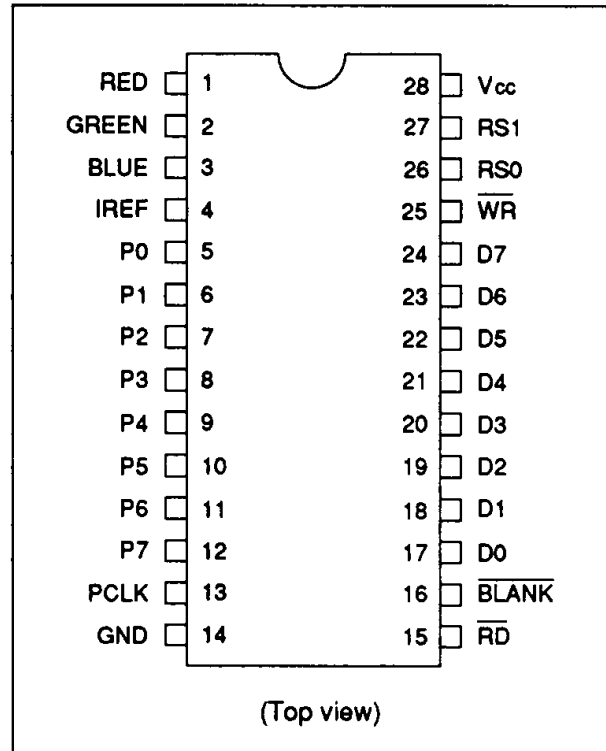
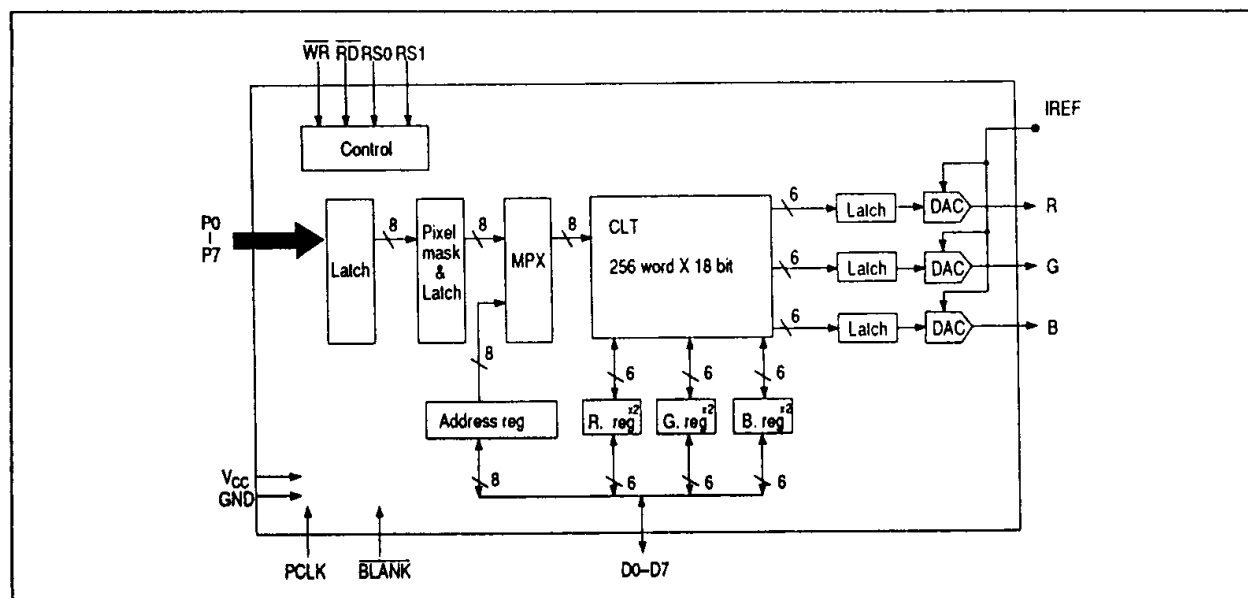

Figure 1 Pin Arrangement

**Block Diagram**



**Figure 2 Block Diagram**

**Table 1 Pin Description**

Pin name	Pin number	Description
P0 – P7	5, 6, 7, 8, 9, 10, 11, 12	CLT address inputs. P7 is MSB, P0 is LSB.
D0 – D7	17, 18, 19, 20, 21, 22, 23, 24	Data port for reading/writing CLT or address, pixel mask, R, G and B registers. D7 is MSB, D0 is LSB.
RD	15	Read clock input. Strokes data from CLT or address, pixel mask, R, G or B registers during read operation.
WR	25	Write clock input. Strokes data to CLT or address, pixel mask, R, G or B registers during write operation.
RS0, RS1	26, 27	Select inputs for CLT, address register or pixel mask register.
IREF	4	Terminal for connecting reference resistor to set DAC analog output level
RED, GREEN BLUE	1, 2, 3	DAC analog output signals
BLANK	16	Video blank input for activating blank signal levels at DAC analog outputs.
PCLK	13	Reference clock input for digital and analog sections. On the rise of this signal, CLT and BLANK operations are processed and analog signal outputs become active.
VCC	28	Power supply
GND	14	Ground



**Functions**

**Accessing the CLT and Registers**

The CLT and registers are selected with inputs RS0 and RS1 (see table 2).

**Table 2 Register Selection**

RS1	RS0	Selection
0	0	Address register (write mode)
1	1	Address register (read mode)
0	1	CLT
1	0	Pixel mask register

**Address register:** To perform read/write operations on the CLT, the CLT address must be set in the address register through D7 to D0 (D7 is the MSB and D0 is the LSB).

For a CLT write operation, write the CLT address via D7 to D0 with RS0 = "0" and RS1 = "0" (in order to select the address register, write mode).

To set up the address register for a CLT read operation, write the CLT address via D7 to D0 with RS0 = "1" and RS1 = "1" (in order to select the address register, read mode).

Also, the address register contents can be read as shown in figure 10 and figure 11.

**Pixel mask register:** The pixel mask register allows displayed colors to be modified by altering the value input from video memory and the contents of the CLT. The pixel mask register is set by writing a pixel mask value to D7 (MSB) to D0 (LSB) with RS0 "0" and RS1 = "1" (in order to select the pixel mask register for a data write) as shown in figure 13. During color palette operations, the value input from video memory at P7 (MSB) to P0 (LSB) is ANDed with the pixel mask register value, and the resulting value is applied as an address to the CLT. Consequently, pixel mask "0" bits will cancel corresponding video memory value "1" bits. The following table shows the CLT address that results for a particular pixel mask register value and video memory value.

**Table 3 Pixel Mask Example**

<b>Pixel mask register</b>	<b>1</b>	<b>0</b>	<b>1</b>	<b>0</b>	<b>1</b>	<b>1</b>	<b>0</b>	<b>1</b>
<b>Address input (P7 – P0)</b>	Pd <sub>7</sub>	Pd <sub>6</sub>	Pd <sub>5</sub>	Pd <sub>4</sub>	Pd <sub>3</sub>	Pd <sub>2</sub>	Pd <sub>1</sub>	Pd <sub>0</sub>
<b>CTL address value</b>	Pd <sub>7</sub>	0	Pd <sub>5</sub>	0	Pd <sub>3</sub>	Pd <sub>2</sub>	0	Pd <sub>0</sub>

**RGB registers:** There are two RGB register types: one for writing color information to the CLT and one for reading color information from the CLT. Each register type is organized as an 18-bit word.

To read or write data to the CLT, set RS0 = '0' to

select the appropriate RGB register write performing the read or write via data port D5 (MSB) to D0 (LSB). Bits D6 and D7 may be either '0' or '1' at this time. Write or read the data in the order of R, G, B as shown in figure 7 and figure 8.

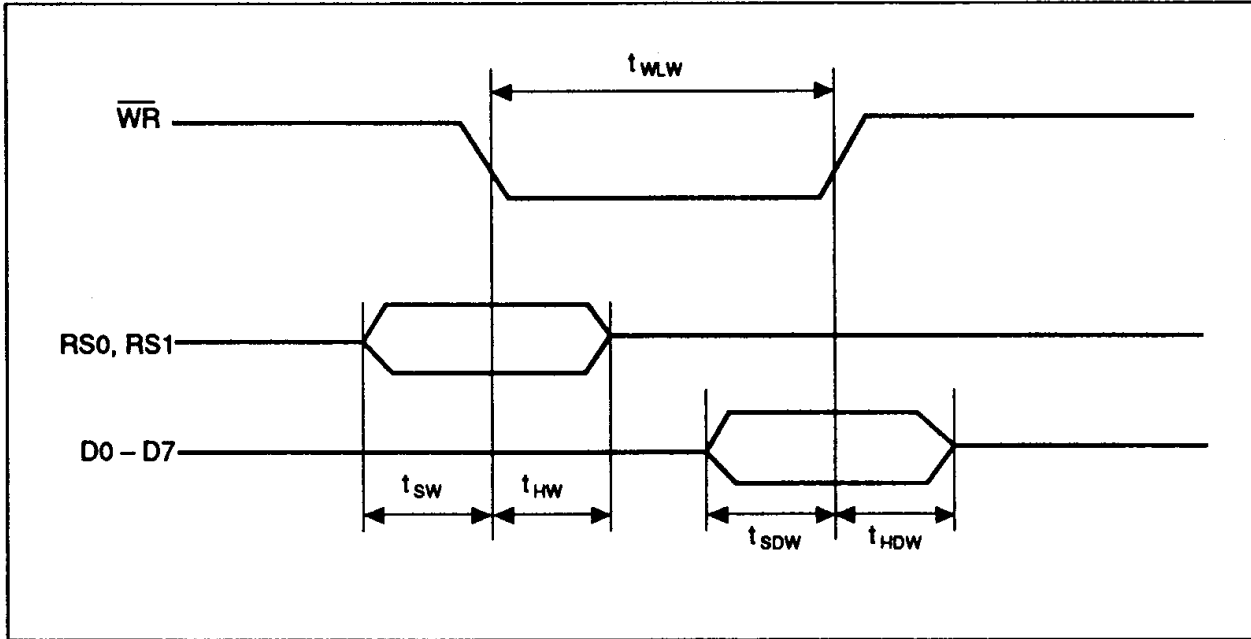

Figure 3 Write Timing

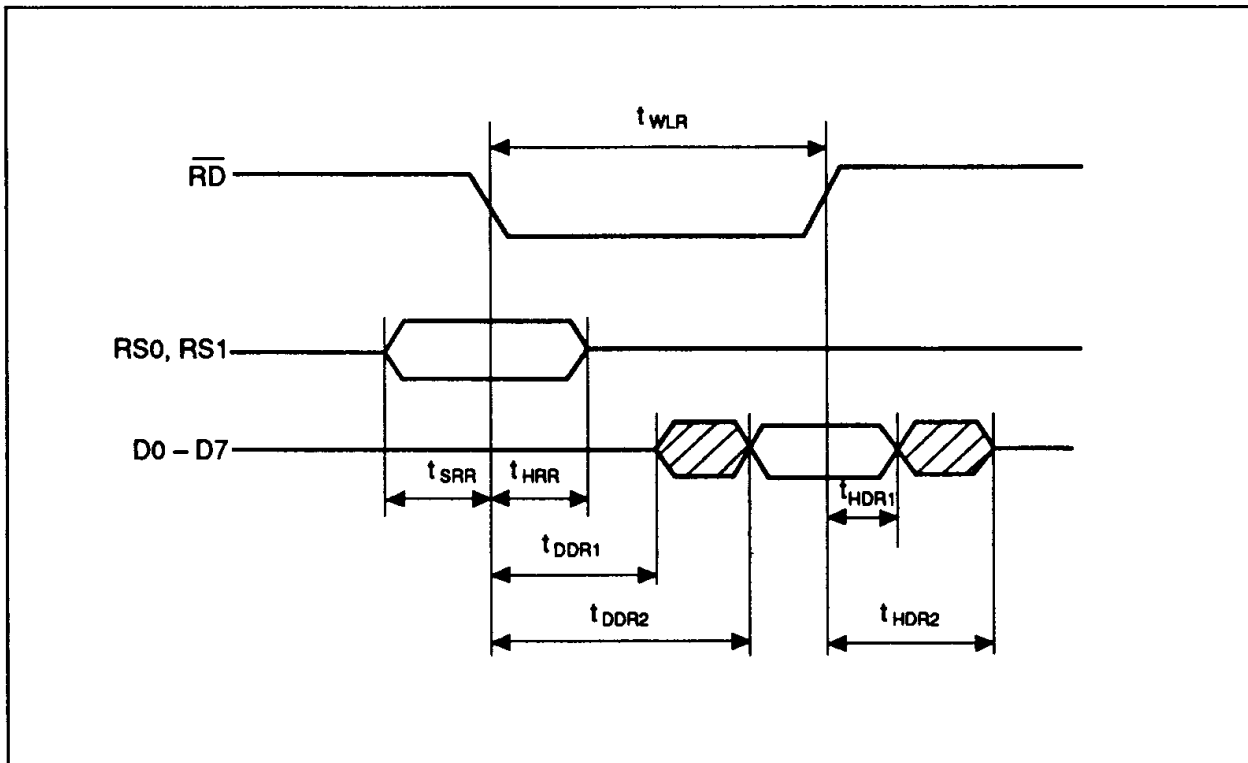

Figure 4 Read Timing

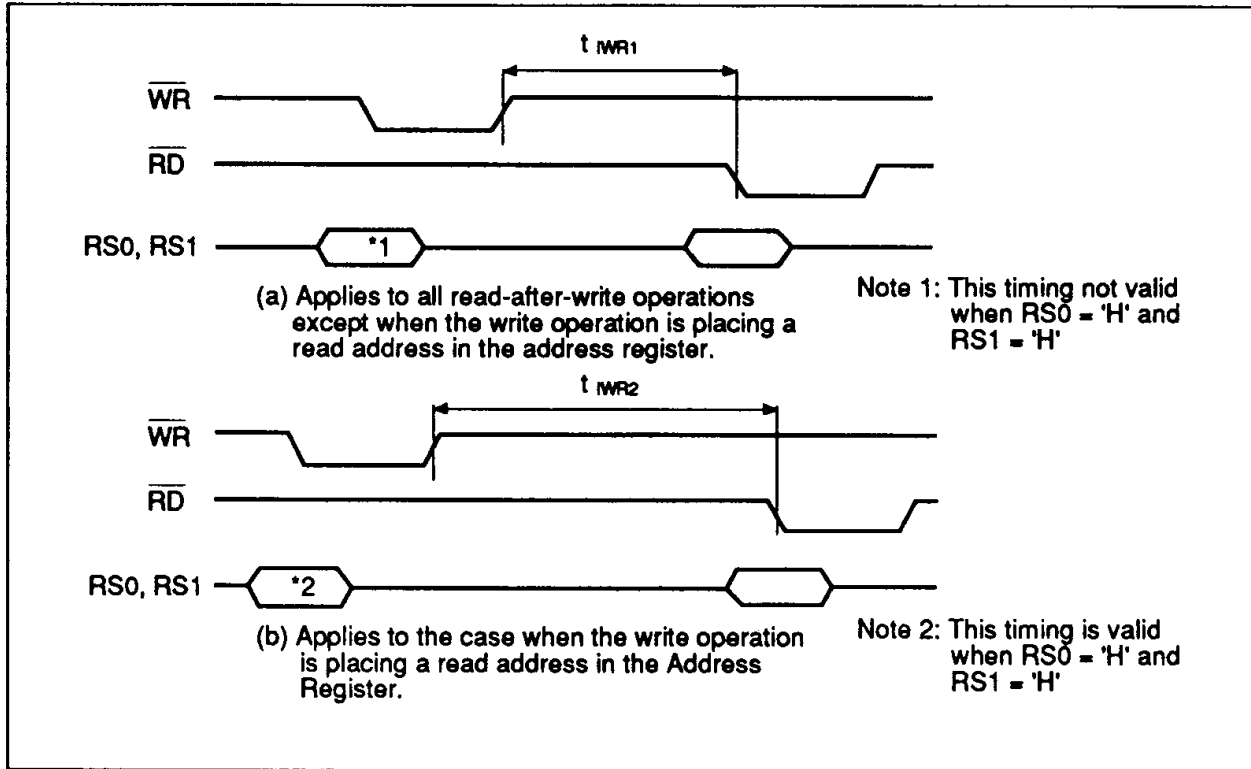

Figure 5 Read after Write

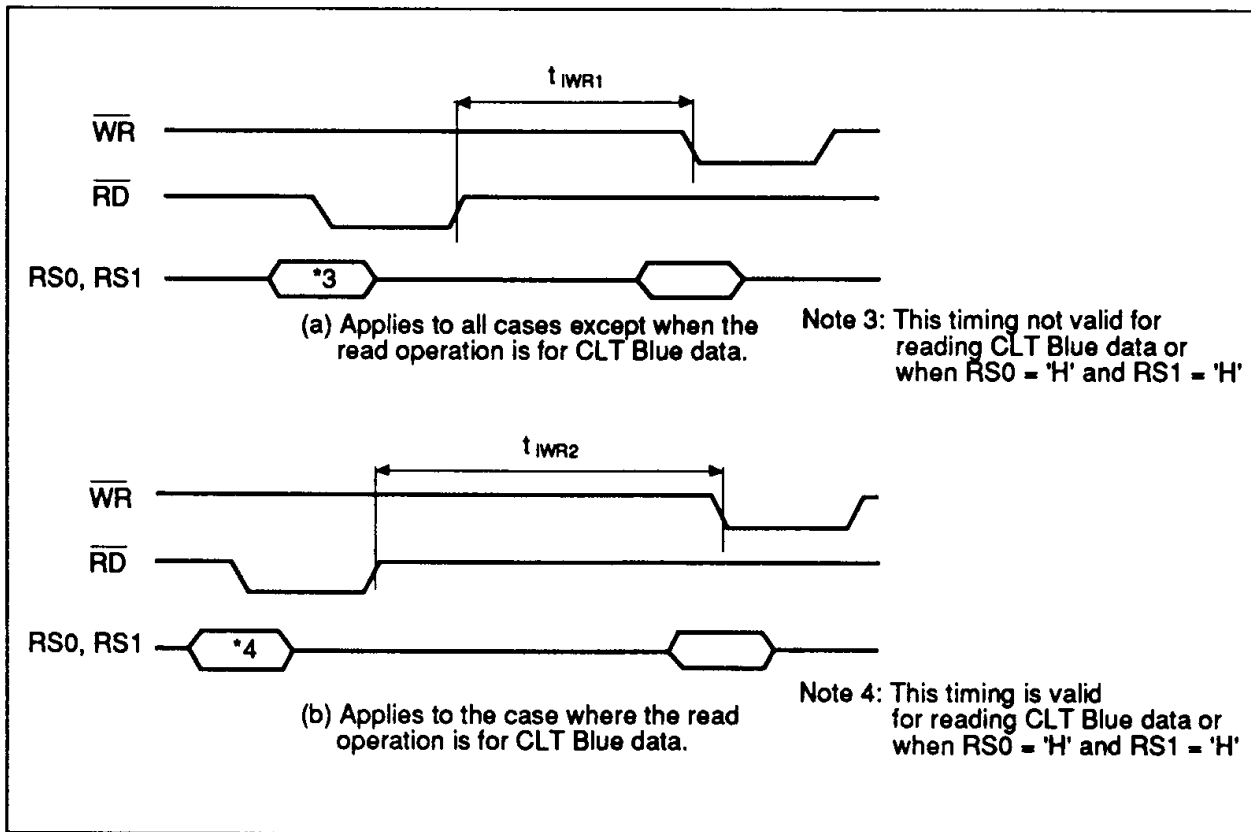

Figure 6 Write after Read



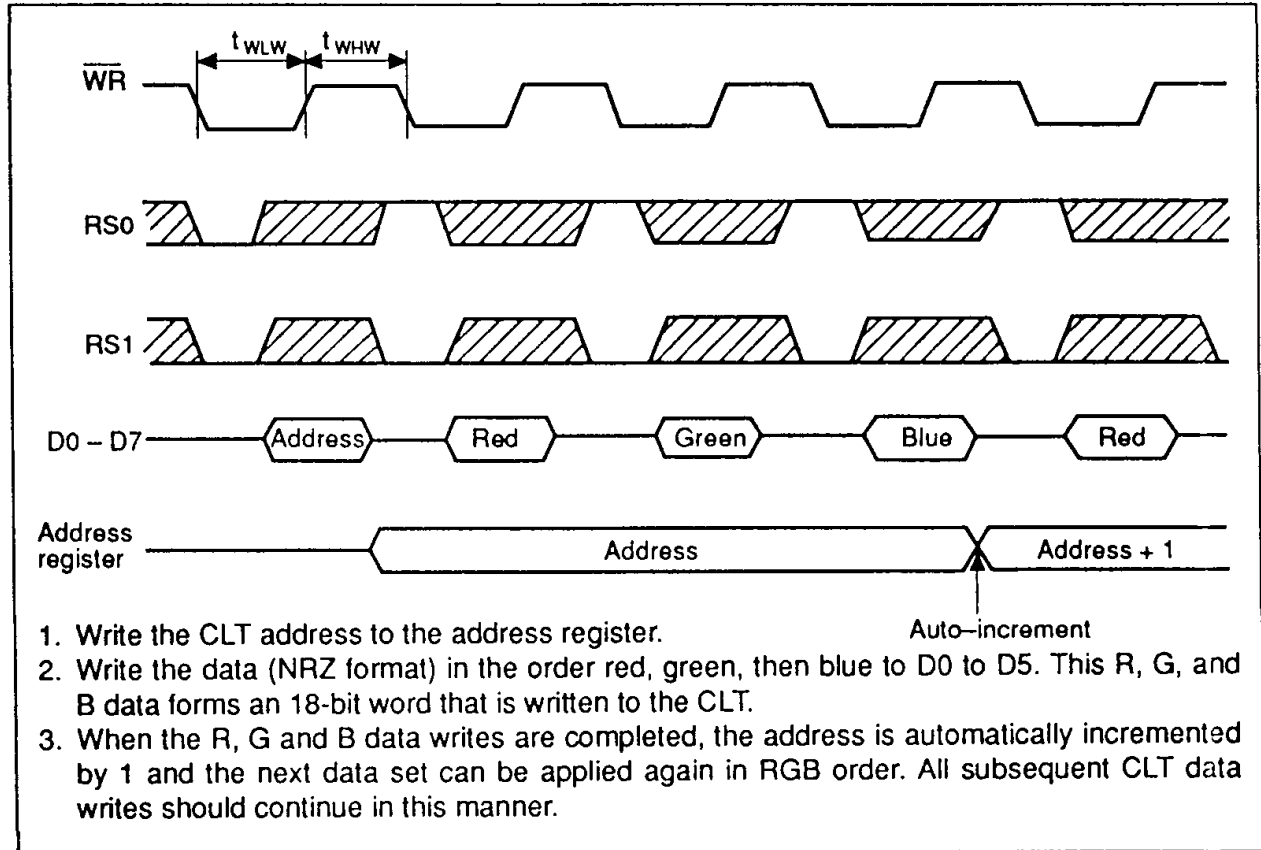

Figure 7 CLT Write

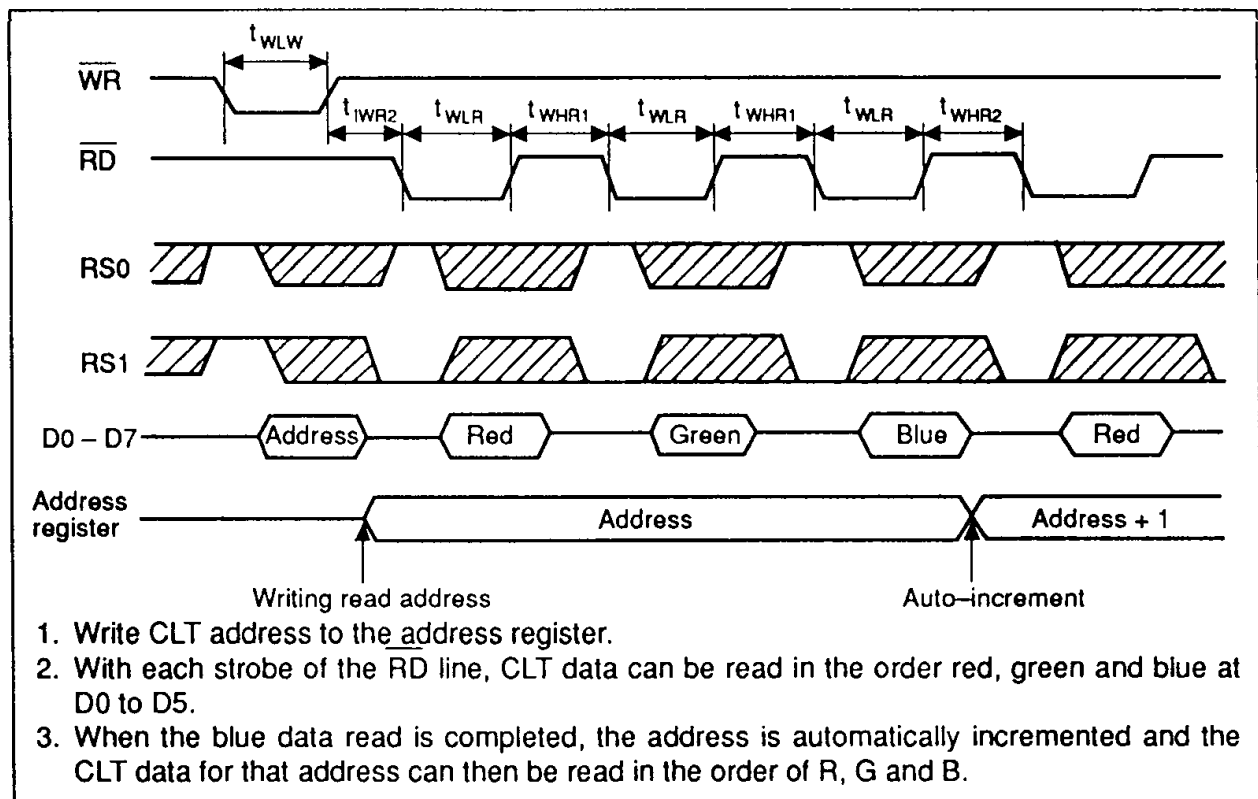

Figure 8 CLT Read

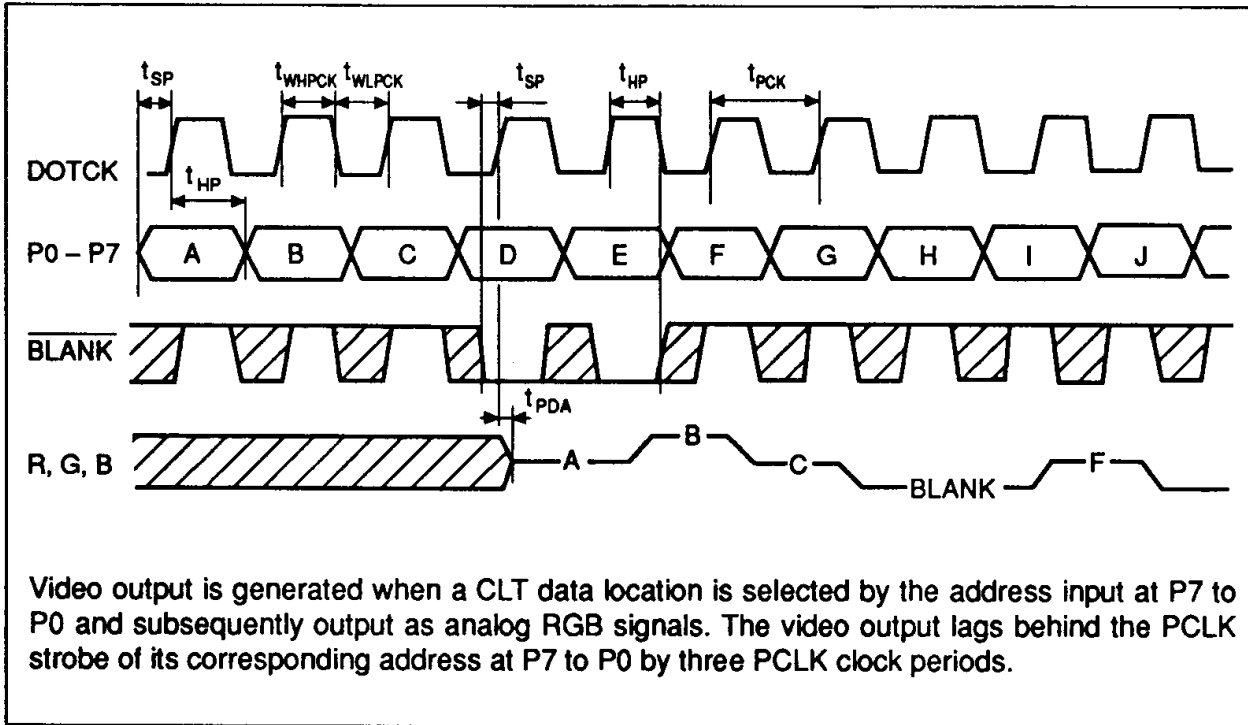

Figure 9 Video Output

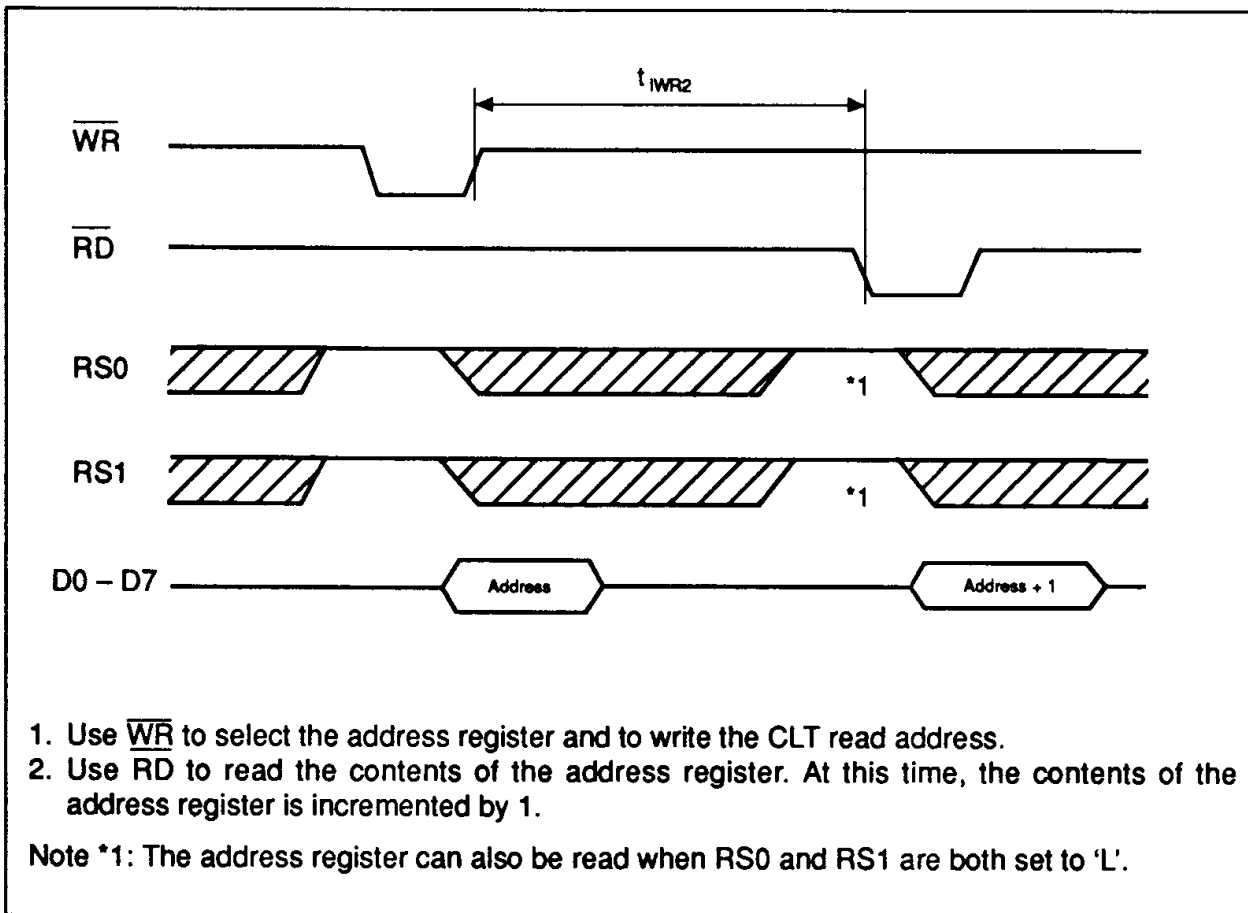

Figure 10 Address Register Read (1)



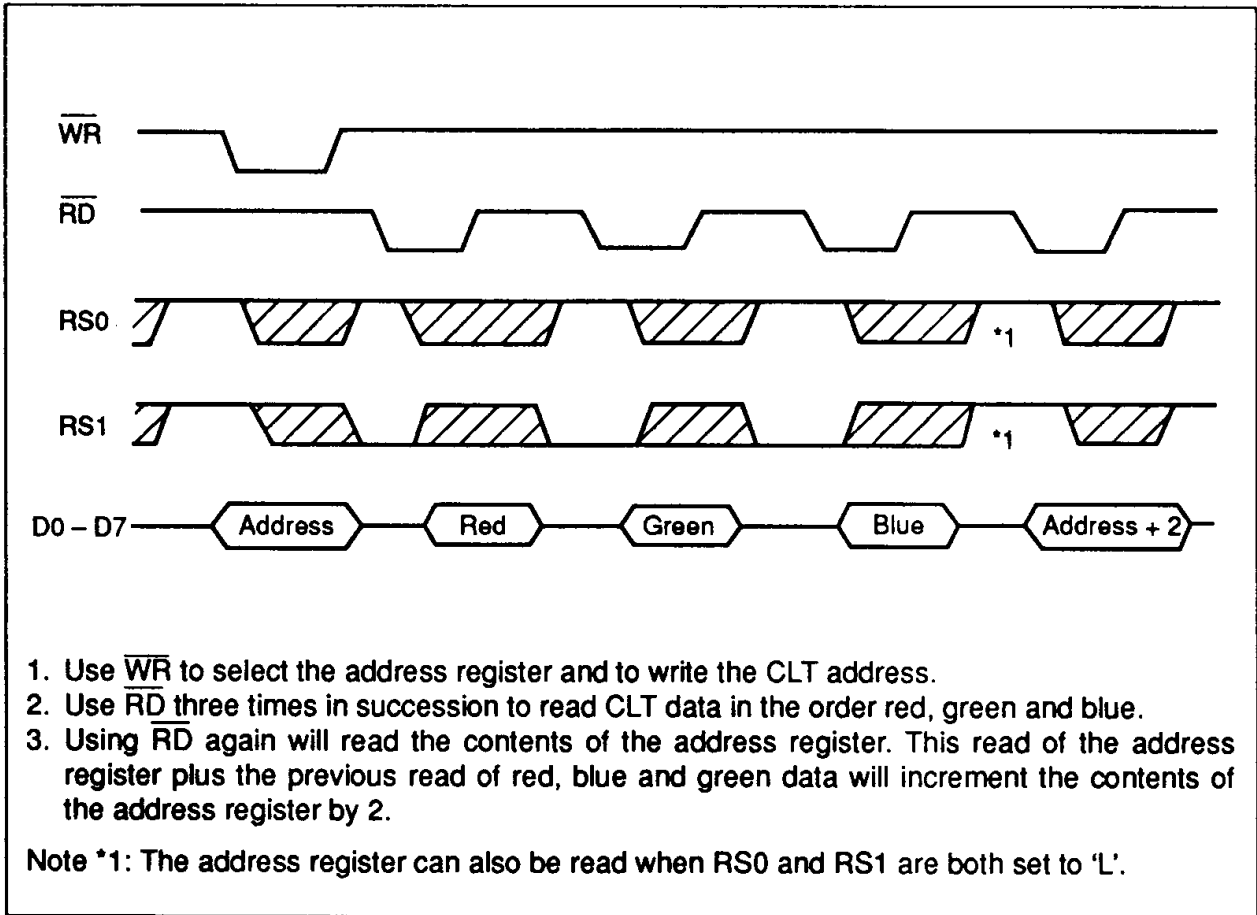

Figure 11 Address Register Read (2)

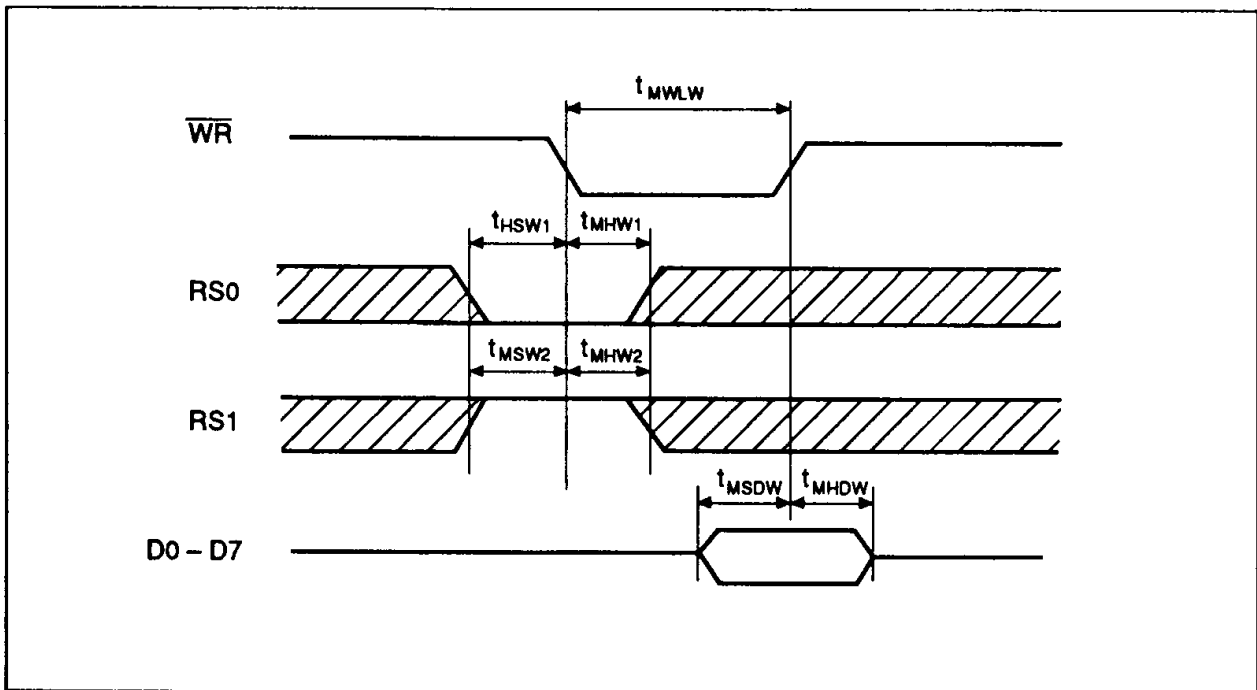

Figure 12 Pixel Mask Register Write



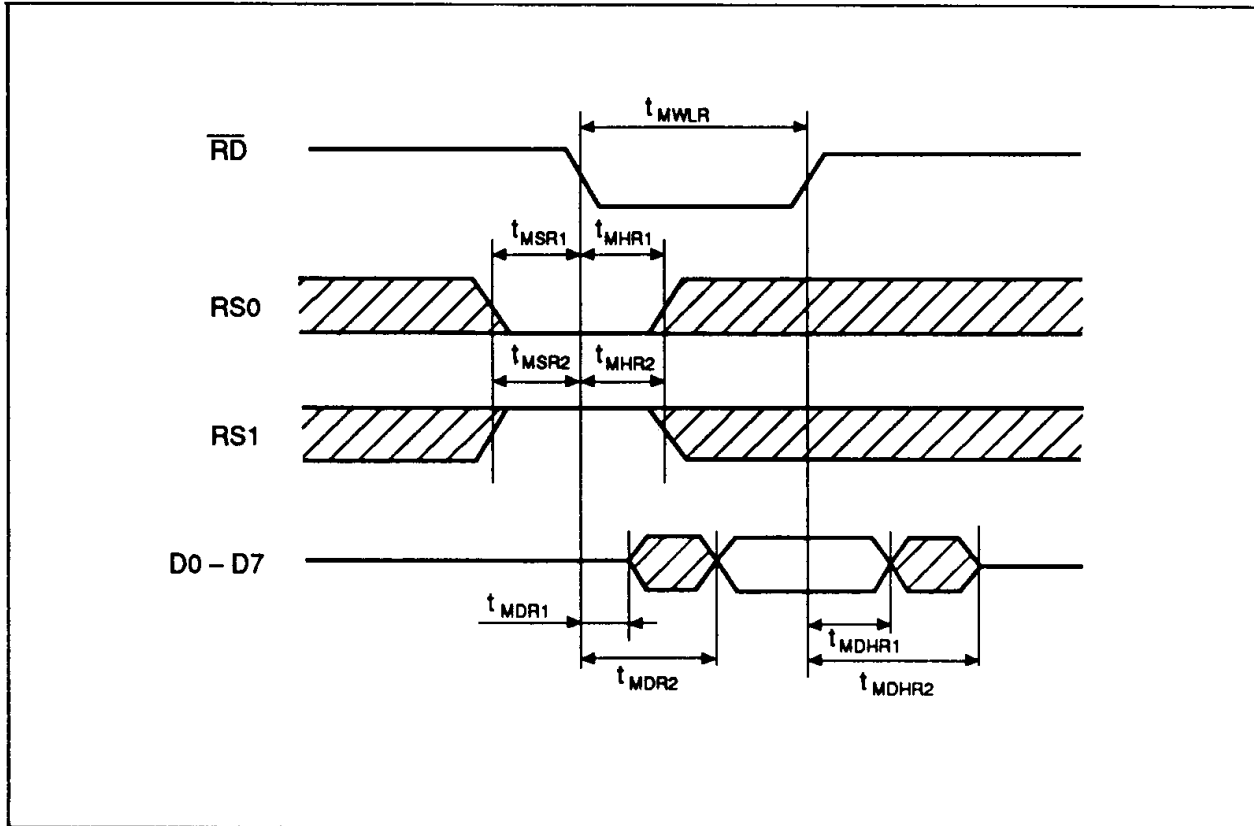

Figure 13 Pixel Mask Register Read

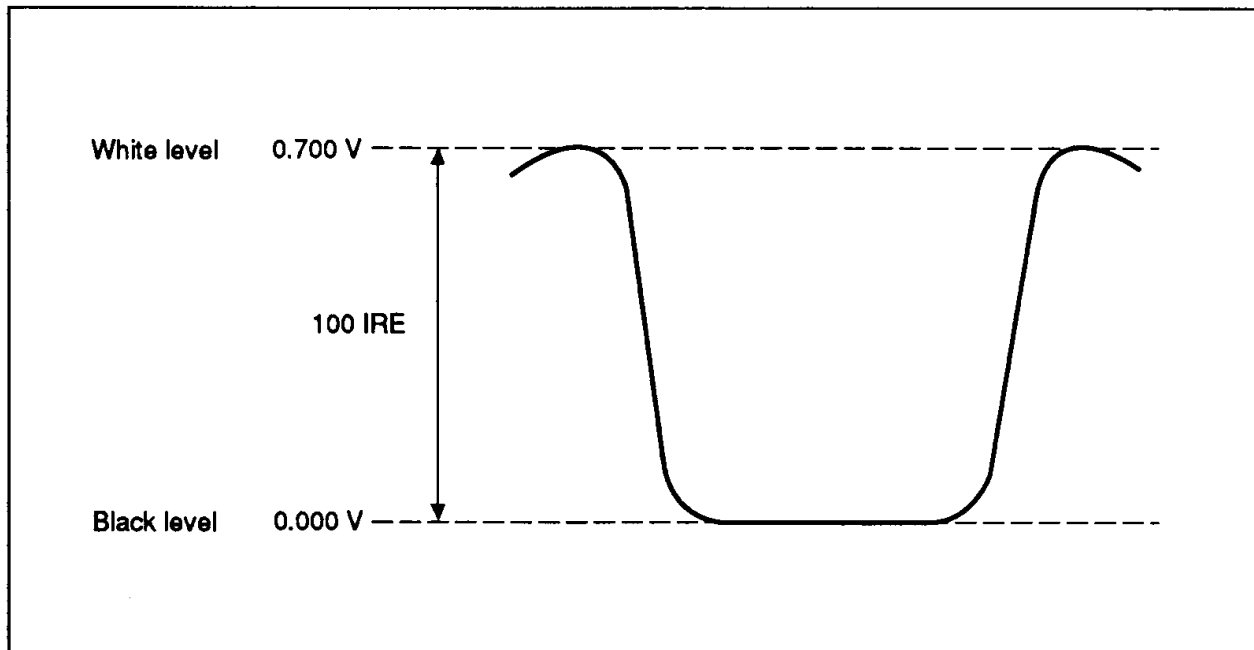
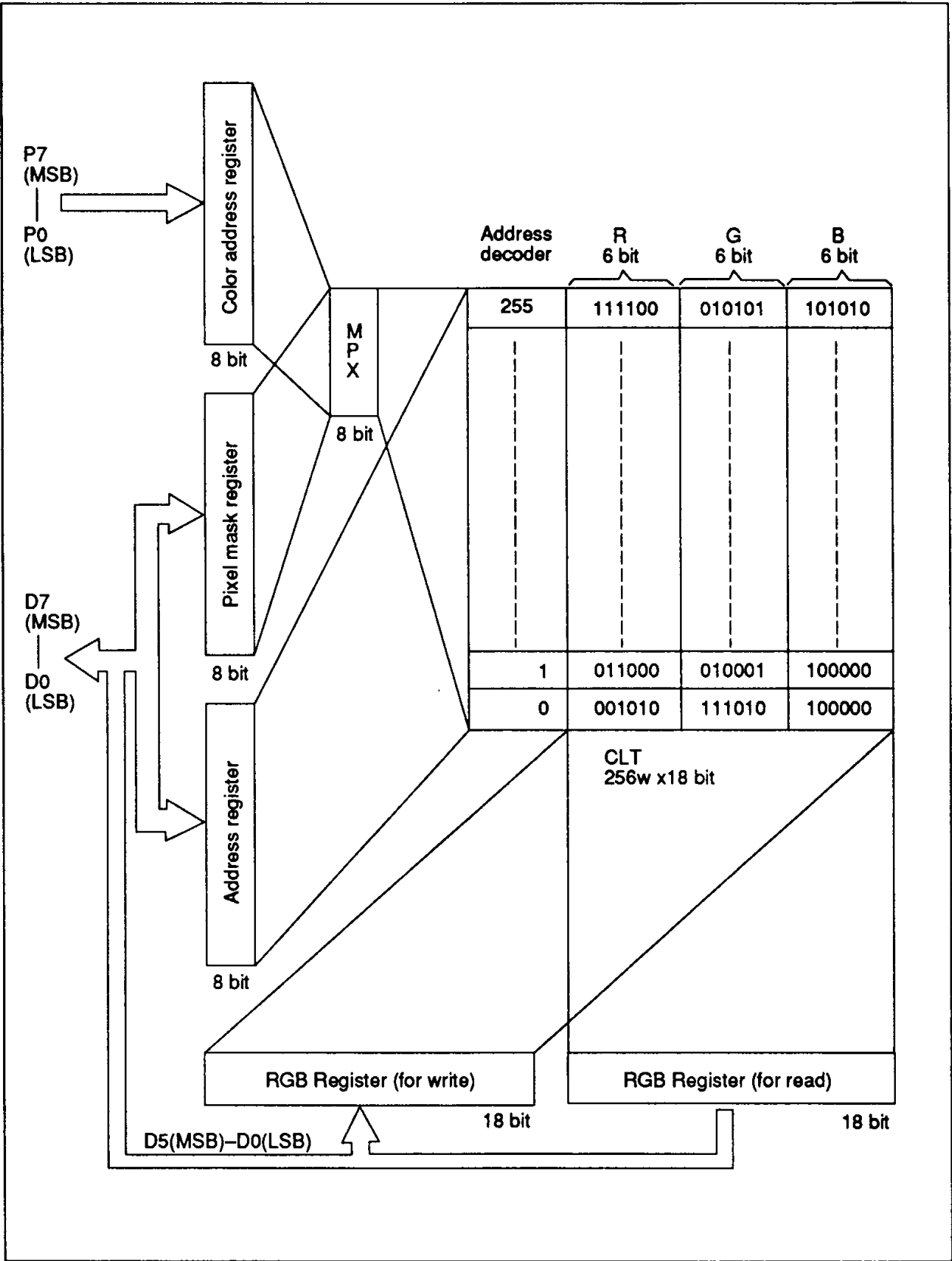

Figure 14 Video Output Waveform

Registers Correspondence with the CLT



2

Figure 15 Registers Correspondence with the CLT



System Configuration Example

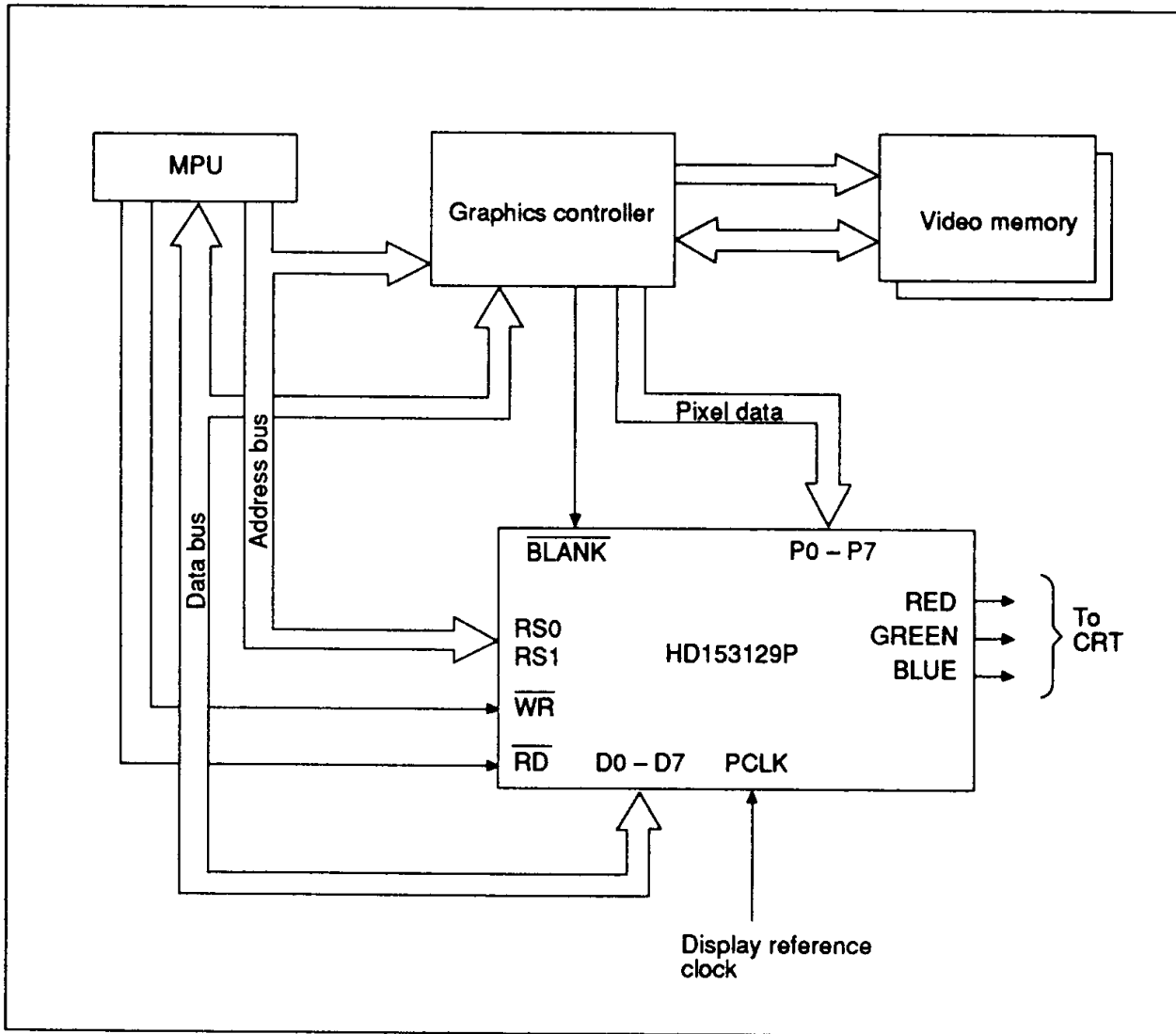

Figure 16 System Configuration Example

Table 4 Absolute Maximum Ratings

Item	Symbol	Rating	Unit
Power supply voltage	$V_{CC}$	7.0	V
Input voltage	$V_{IN}$	0 to $V_{CC}$	V
Operating temperature	$T_{opr}$	0 to +70	°C
Storage temperature	$T_{stg}$	-55 to +150	°C

## Electrical Characteristics

**Table 5 DAC Section Electrical Characteristics ( $V_{CC} = 5\text{ V}$ ,  $T_a = 25\text{ }^\circ\text{C}$ )**

Item	Symbol	Min	Typ	Max	Unit	Test conditions
Resolution		6	6	6	bits	
Maximum operating frequency	$f_{CLK}$	—	—	50/65	MHz	
Analog output voltage	$V_A$ (Full)	-5	—	5	% of FSR	
$I_{REF} = -4.44\text{ mA}$	$V_A$ (Zero)	-2	—	2	% of FSR	
Differential linearity	DLE	-1	—	+1	LSB	
Integral linearity	ILE	-1	—	+1	LSB	
Output rise time (20 – 80 %)	$t_r$	—	—	10	ns	$C_L = 15\text{ pF}$
Output fall time (80 – 20 %)	$t_f$	—	—	10	ns	$C_L = 15\text{ pF}$
Settling time	$t_s$	—	—	30	ns	$C_L = 15\text{ pF}$
Glitch energy	$E_G$	—	90	—	PVS	

**Table 6 Digital Section DC Characteristics**  
(unless otherwise specified  $V_{CC} = 5\text{ V} \pm 5\%$ ,  $T_a = 0\text{ to }+70\text{ }^\circ\text{C}$ )

Item	Symbol	Min	Typ	Max	Unit	Test conditions
Input "High" level voltage	$V_{IH}$	2.2	—	$V_{CC}$	V	
Input "Low" level voltage	$V_{IL}$	-0.3	—	0.8	V	
Input clamp voltage	$V_I$	—	—	-1.5	V	$V_{CC} = 4.75\text{ V}$ , $I_{IN} = -18\text{ mA}$
Output "High" level voltage	$V_{OH}$	2.7	—	—	V	$V_{CC} = 4.75\text{ V}$ , $I_{OH} = -400\text{ }\mu\text{A}$
Output "Low" level voltage	$V_{OL}$	—	—	0.5	V	$V_{CC} = 4.75\text{ V}$ , $I_{OL} = 8\text{ mA}$
Input current	$I_I$	—	—	1	mA	$V_{CC} = 5.25\text{ V}$ , $V_I = 5.5\text{ V}$
"High" level input current	$I_{IH}$	—	—	20	$\mu\text{A}$	$V_{CC} = 5.25\text{ V}$ , $V_I = 2.7\text{ V}$
"Low" level input current	$I_{IL}$	—	—	-400	$\mu\text{A}$	$V_{CC} = 5.25\text{ V}$ , $V_I = 0.4\text{ V}$
Supply current	$I_{CC}$	—	110	170	mA	$V_{CC} = 5.25\text{ V}$ , $I_{REF} = -4.44\text{ mA}$

# HD153129

**Table 7 Digital Section AC Characteristics ( $V_{CC} = 5\text{ V}$ ,  $T_a = 25\text{ }^\circ\text{C}$ )**

Item	Symbol	50 MHz		65 MHz		Unit	Test conditions	Reference figure
		Min	Max	Min	Max			
PCLK cycle time	$t_{PCK}$	20	—	15.3	—	ns		9
PCLK low level time	$t_{WLPCK}$	8	—	6	—	ns		9
PCLK high level time	$t_{WHPCK}$	8	—	6	—	ns		9
Data setup time	$t_{SP}$	6	—	5	—	ns		9
Data hold time	$t_{HP}$	6	—	5	—	ns		9
Data output delay time	$t_{PDA}$	—	30	—	30	ns	$C_L = 15\text{ pF}$	9
$\overline{WR}$ low level time	$t_{WLW}$	50	—	50	—	ns		3, 7, 8
$\overline{WR}$ high level time	$t_{WHW}$	$3 \times t_{DCK}$	—	$3 \times t_{DCK}$	—	ns		7
$\overline{RD}$ low level time	$t_{WLR}$	50	—	50	—	ns		4, 8
$\overline{RD}$ high level time	$t_{WHR1}$	$3 \times t_{DCK}$	—	$3 \times t_{DCK}$	—	ns		8
	$t_{WHR2}$	$6 \times t_{DCK}$	—	$6 \times t_{DCK}$	—	ns		8
$\overline{WR}/\overline{RD}$ interval time	$t_{IWR1}$	$3 \times t_{DCK}$	—	$3 \times t_{DCK}$	—	ns		5, 6
	$t_{IWR2}$	$6 \times t_{DCK}$	—	$6 \times t_{DCK}$	—	ns		5, 6, 8, 9
$\overline{WR}/RS0, RS1$ setup time	$t_{SW}$	10	—	10	—	ns		3
$\overline{WR}/RS0, RS1$ hold time	$t_{HW}$	10	—	10	—	ns		3
$\overline{RD}/RS0, RS1$ setup time	$t_{SRR}$	10	—	10	—	ns		4
$\overline{RD}/RS0, RS1$ hold time	$t_{HRR}$	10	—	10	—	ns		4
$\overline{WR}$ data setup time	$t_{SDW}$	10	—	10	—	ns		3
$\overline{WR}$ data hold time	$t_{HDW}$	10	—	10	—	ns		3
$\overline{RD}$ data output delay time	$t_{DDR1}$	5	—	5	—	ns	$C_L = 15\text{ pF}$	4
	$t_{DDR2}$	—	40	—	40	ns	$C_L = 15\text{ pF}$	4
$\overline{RD}$ data output hold time	$t_{HDR1}$	5	—	5	—	ns	$C_L = 15\text{ pF}$	4
	$t_{HDR2}$	—	20	—	20	ns	$C_L = 15\text{ pF}$	4
$\overline{WR}$ low level time	$t_{MWLW}$	50	—	50	—	ns		12
$\overline{RD}$ low level time	$t_{MWLR}$	50	—	50	—	ns		13
$\overline{WR}/RS0, RS1$ setup time	$t_{MSW1}$	10	—	10	—	ns		12
	$t_{MSW2}$	10	—	10	—	ns		12

Unit mm (inch)



Digital Section AC Characteristics ( $V_{CC} = 5\text{ V}$ ,  $T_a = 25\text{ }^\circ\text{C}$ ) (cont)

Item	Symbol	50 MHz		65 MHz		Unit	Test conditions	Reference figure
		Min	Max	Min	Max			
$\overline{WR}/RS_0$ , RS1 hold time	$t_{MHW1}$	10	—	10	—	ns		12
	$t_{MHW2}$	10	—	10	—	ns		12
$\overline{RD}/RS_0$ , RS1 setup time	$t_{MSR1}$	10	—	10	—	ns		13
	$t_{MSR2}$	10	—	10	—	ns		13
$\overline{RD}/RS_0$ , RS1 hold time	$t_{MHR1}$	10	—	10	—	ns		13
	$t_{MHR2}$	10	—	10	—	ns		13
$\overline{WR}$ data setup time	$t_{MSDW}$	10	—	10	—	ns		12
$\overline{WR}$ data hold time	$t_{MHDW}$	10	—	10	—	ns		12
$\overline{RD}$ data output delay time	$t_{MDR1}$	5	—	5	—	ns	$C_L = 15\text{ pF}$	13
	$t_{MDR2}$	—	40	—	40	ns	$C_L = 15\text{ pF}$	13
$\overline{RD}$ data output hold time	$t_{MDHR1}$	5	—	5	—	ns	$C_L = 15\text{ pF}$	13
	$t_{MDHR2}$	—	20	—	20	ns	$C_L = 15\text{ pF}$	13

2

Connection Example

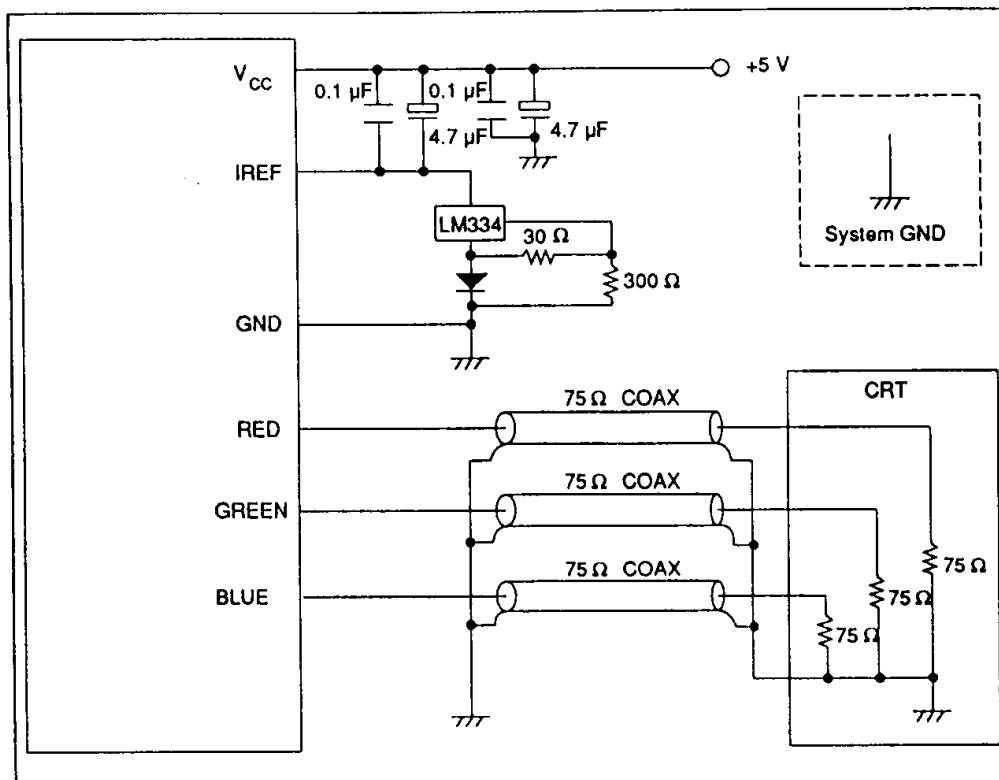

Figure 17 Connection Example

