

HD151BF854

2.5 V PLL Clock Buffer for DDR Application

REJ03D0809-0500
 (Previous: ADE-205-696D)
 Rev.5.00
 Apr 07, 2006

Description

The HD151BF854 is a high-performance, low-skew, low-jitter, PLL clock buffer. It is specifically designed for use with DDR (Double Data Rate) PC motherboard application.

Features

- Designed for DDR200/266/333/400 PC mother board clock buffering
- Supports 60 MHz to 210 MHz operation range
- Distributes one to six differential clock outputs pairs
- Spread spectrum clock compatible
- External feedback pin (FBIN) is used to synchronize the outputs to the clock input
- Supports 2.5 V analog supply voltage (AVDD), and 2.5 V VDD
- Ordering Information

Part Name	Package Type	Package Code (Previous Code)	Package Abbreviation	Taping Abbreviation (Quantity)
HD151BF854SSEL	SSOP-28 pin	PRSP0028JA-A (FP-28DSAV)	SS	EL (1,000 pcs / Reel)

Key Specifications

- Supply voltages: VDD = AVDD = 2.5 V \pm 0.2 V
- Output clock cycle to cycle jitter = \pm 75 ps
- Output clock pin to pin skew = 150 ps

Function Table

Inputs		Outputs			PLL
AVDD	CLK	Yn	$\bar{Y}n$	FBOUT	
GND	L	L	H	L	Bypass / Off
GND	H	H	L	H	Bypass / Off
2.5 V (typ.)	L	L	H	L	Running
2.5 V (typ.)	H	H	L	H	Running

H: High level

L: Low level

Pin Arrangement

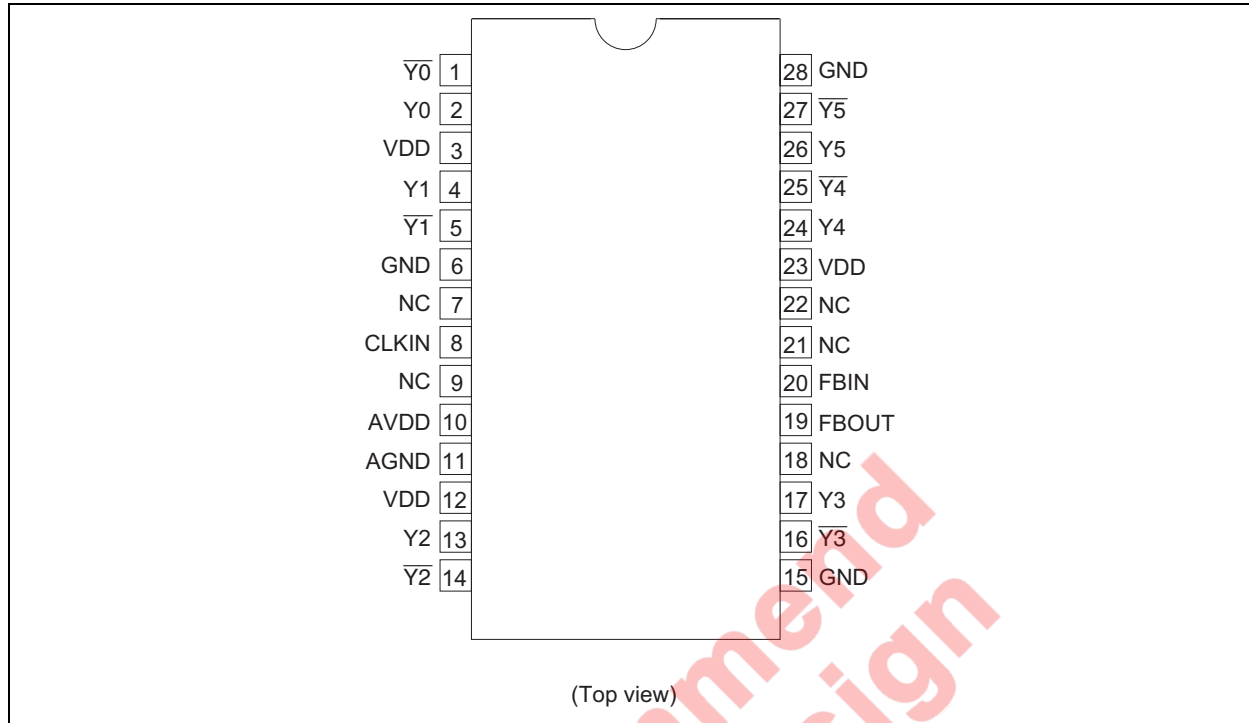

Pin Functions

Pin name	No.	Type	Description
AGND	11	Ground	Analog ground. AGND provides the ground reference for the analog circuitry.
AVDD	10	Power	Analog power supply. AVDD provides the power reference for the analog circuitry. In addition, AVDD can be used to bypass the PLL for test purposes. When AVDD is strapped to ground, PLL is bypassed and CLK is buffered directly to the device outputs.
CLKIN	8	Input	Clock input. CLKIN provides the clock signal to be distributed by the HD151BF854 clock buffer. CLK is used to provide the reference signal to the integrated PLL that generates the clock output signals. CLK must have a fixed frequency and fixed phase for the PLL to obtain phase lock. Once the circuit is powered up and a valid CLK signal is applied, a stabilization time is required for the PLL to phase lock the feedback signal to its reference signal.
FBIN	20	Input	Feedback input. FBIN provides the feedback signal to the internal PLL. FBIN must be hard-wired to FBOUT to complete the PLL. The integrated PLL synchronizes CLKIN and FBIN so that there is nominally zero phase error between CLKIN and FBIN.
FBOUT	19	Output	Feedback output. FBOUT is dedicated for external feedback. It switches at the same frequency as CLK. When externally wired to FBIN, FBOUT completes the feedback loop of the PLL.
GND	6, 15, 28	Ground	Ground
VDD	3, 12, 23	Power	Power supply
Y	2, 4, 13, 17, 24, 26	Output	Clock outputs. (+Clock) These outputs provide low-skew copies of CLK.
\bar{Y}	1, 5, 14, 16, 25, 27	Output	Bar clock outputs. (-Clock) These outputs provide low-skew copies of CLK.
NC	7, 9, 18, 21, 22	NC	Don't connect any VDD or GND.

Logic Diagram

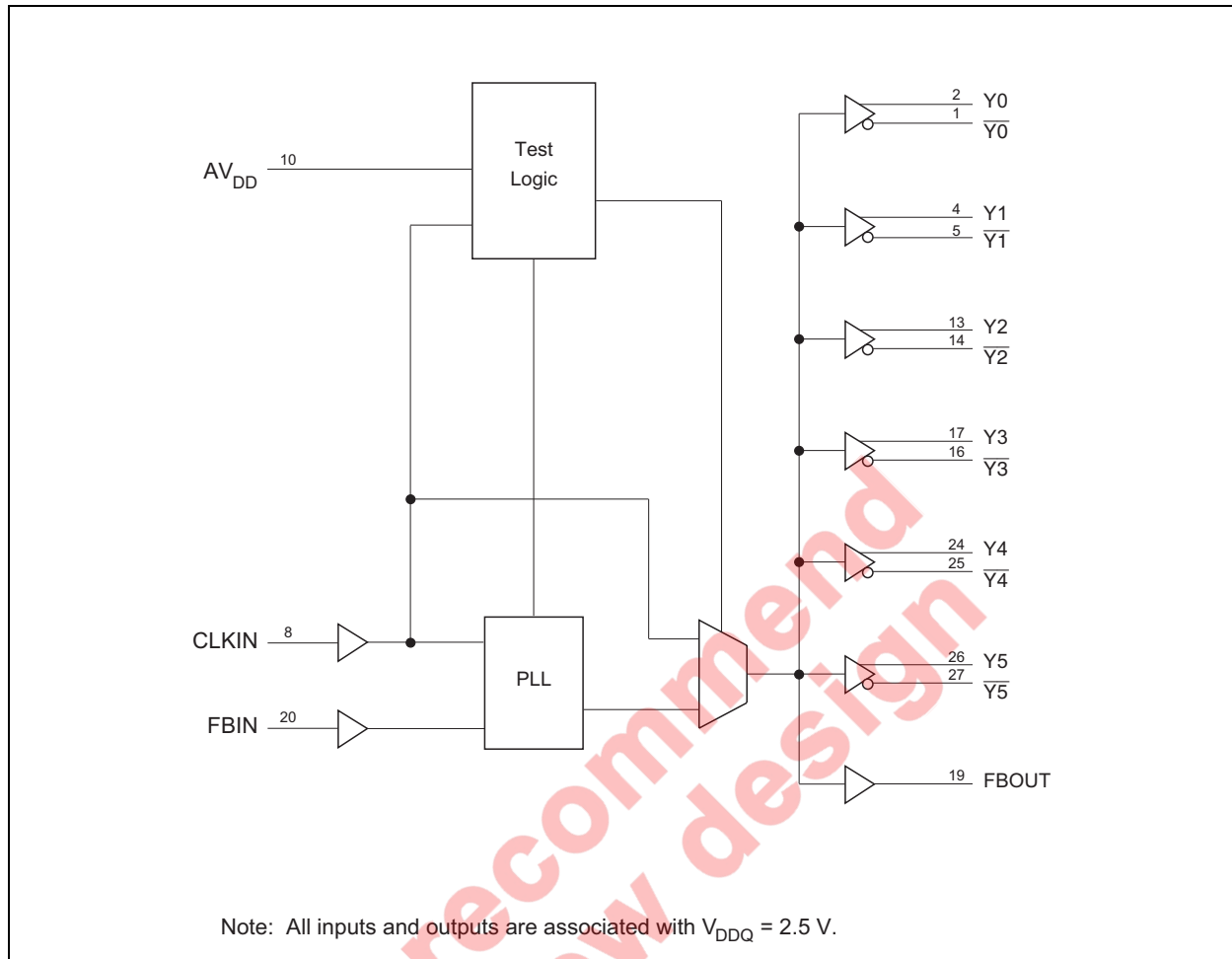

Absolute Maximum Ratings

Item	Symbol	Ratings	Unit	Conditions
Supply voltage	VDD	-0.5 to 3.6	V	
Input voltage	V _{IC}	-0.5 to 3.6	V	CLKIN
	V _I	-0.5 to VDD+0.5	V	
Output voltage *1	V _O	-0.5 to VDD+0.5	V	
Input clamp current	I _{IK}	-50	mA	V _I < 0
Output clamp current	I _{OK}	-50	mA	V _O < 0
Continuous output current	I _O	±50	mA	V _O = 0 to VDD
Maximum power dissipation at Ta = 55°C (in still air)		0.7	W	
Storage temperature	T _{stg}	-65 to +150	°C	

Notes: Stresses beyond those listed under “absolute maximum ratings” may cause permanent damage to the device. These are stress ratings only, and functional operation of the device at these or any other conditions beyond those indicated under “recommended operating conditions” is not implied. Exposure to absolute maximum rated conditions for extended periods may affect device reliability.

1. The input and output negative voltage ratings may be exceeded if the input and output clamp current ratings are observed.

Recommended Operating Conditions

Item	Symbol	Min	Typ	Max	Unit	Conditions
Supply voltage	AVDD	2.3	2.5	2.7	V	
Output supply voltage	VDD	2.3	2.5	2.7	V	
DC input signal voltage		-0.3	—	VDD+0.3	V	All pins
High level input voltage	V _{IH}	1.7	—	3.6	V	CLKIN
High level input voltage	V _{IH}	1.7	—	VDD+0.3	V	FBIN
Low level input voltage	V _{IL}	-0.3	—	0.7	V	CLKIN, FBIN
Output differential cross point voltage	V _{OX}	0.5×VDD -0.2	—	0.5×VDD +0.2	V	
Output current	I _{OH}	—	—	-12	mA	
	I _{OL}	—	—	12		
Input clock slew rate	SR	1	—	—	V/ns	
Operating temperature	T _a	0	—	70	°C	

Note: Unused inputs must be held high or low to prevent them from floating.

Electrical Characteristics

Item	Symbol	Min	Typ ^{*1}	Max	Unit	Test Conditions
Input clamp voltage (All inputs)	V _{IK}	—	—	-1.2	V	I _I = -18 mA, VDD = 2.3 V
Output voltage	V _{OH}	VDD-0.2	—	—	V	I _{OH} = -100 μA, VDD = 2.3 to 2.7 V
		1.7	—	VDD		I _{OH} = -12 mA, VDD = 2.3 V
	V _{OL}	—	—	0.2		I _{OL} = 100 μA, VDD = 2.3 to 2.7 V
		—	—	0.6		I _{OL} = 12 mA, VDD = 2.3 V
Input current	I _I	-10	—	10	μA	V _I = 0 V or 2.7 V, VDD = 2.7 V, CLKIN, FBIN
Analog supply current	A _{Icc}	—	—	12	mA	VDD = AVDD = 2.7 V, 170 MHz
Dynamic supply current	D _{Icc}	—	250	300	mA	VDD = AVDD = 2.7 V, 170 MHz, All Y _n , \bar{Y}_n , = open
Input capacitance ^{*2}	C _I	2.5	—	3.5	pF	CLKIN and FBIN
Delta input capacitance ^{*2}	C _{DI}	-0.25	—	0.25	pF	

Notes: 1. For conditions shown as Min or Max, use the appropriate value specified under recommended operating conditions.

2. Target of design, not 100% tested in production.

Switching Characteristics

Ta = 25°C, VDD = AVDD = 2.5V

Item	Symbol	Min	Typ	Max	Unit	Test Conditions & Notes
Period jitter	t _{PER}	—	75	—	ps	*7, 8
Half period jitter	t _{HPER}	—	120	—	ps	*8
Cycle to cycle jitter	t _{CC}	—	75	—	ps	
Static phase offset	t _{sPE}	—	150	—	ps	*4, 5
Output clock skew	t _{sk}	—	150	—	ps	
Operating clock frequency	f _{CLK(O)}	60	—	210	MHz	*1, 2
Application clock frequency	f _{CLK(A)}	80	166	210	MHz	*1, 3
Slew rate		1.0	—	2.0	V/ns	20% to 80%
Stabilization time		—	—	0.1	ms	*6

Notes: Target of design, not 100% tested in production.

1. The PLL must be able to handle spread spectrum induced skew. (the specification for this frequency modulation can be found in the latest Intel PC100 Registered DIMM specification)
2. Operating clock frequency indicates a range over which the PLL must be able to lock, but in which it is not required to meet the other timing parameters. (Used for low speed system debug.)
3. Application clock frequency indicates a range over which the PLL must meet all timing parameters.
4. Assumes equal wire length and loading on the clock output and feedback path.
5. Static phase offset does not include jitter.
6. Stabilization time is the time required for the integrated PLL circuit to obtain phase lock of it's feedback signal to it's reference signal after power on.
7. Period jitter defines the largest variation in clock period, around a nominal clock period.
8. Period jitter and half period jitter are separate specifications that must be met independently of each other.

Not recommended for new design

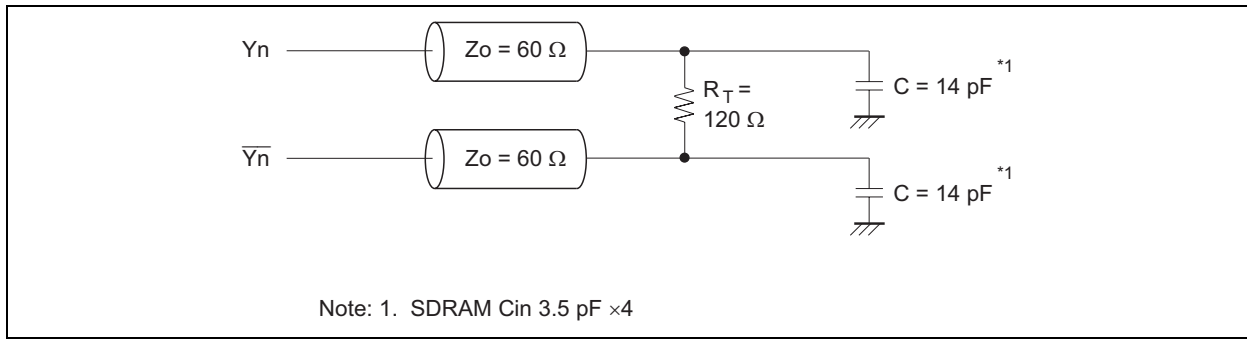

Figure 1 Clock outputs test circuit

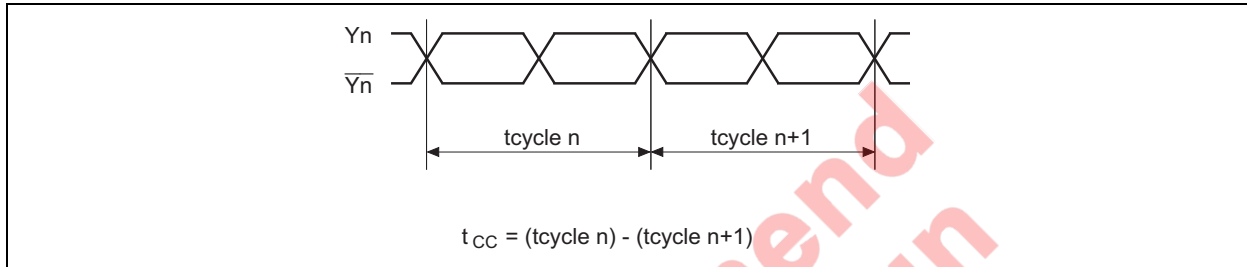

Figure 2 Cycle to cycle jitter

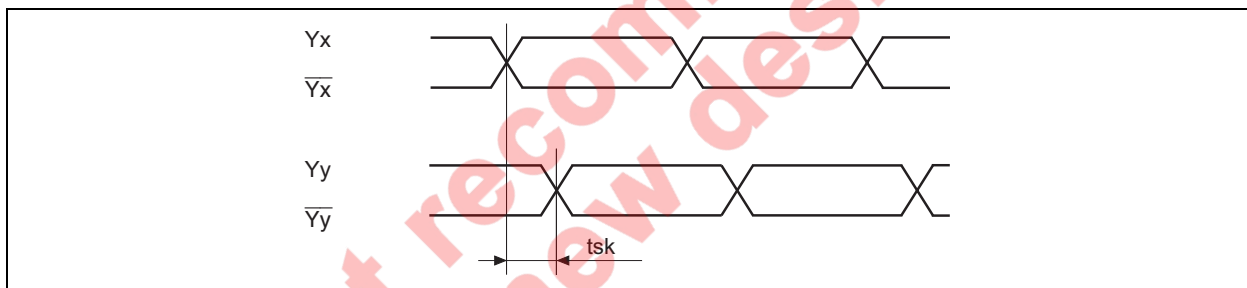
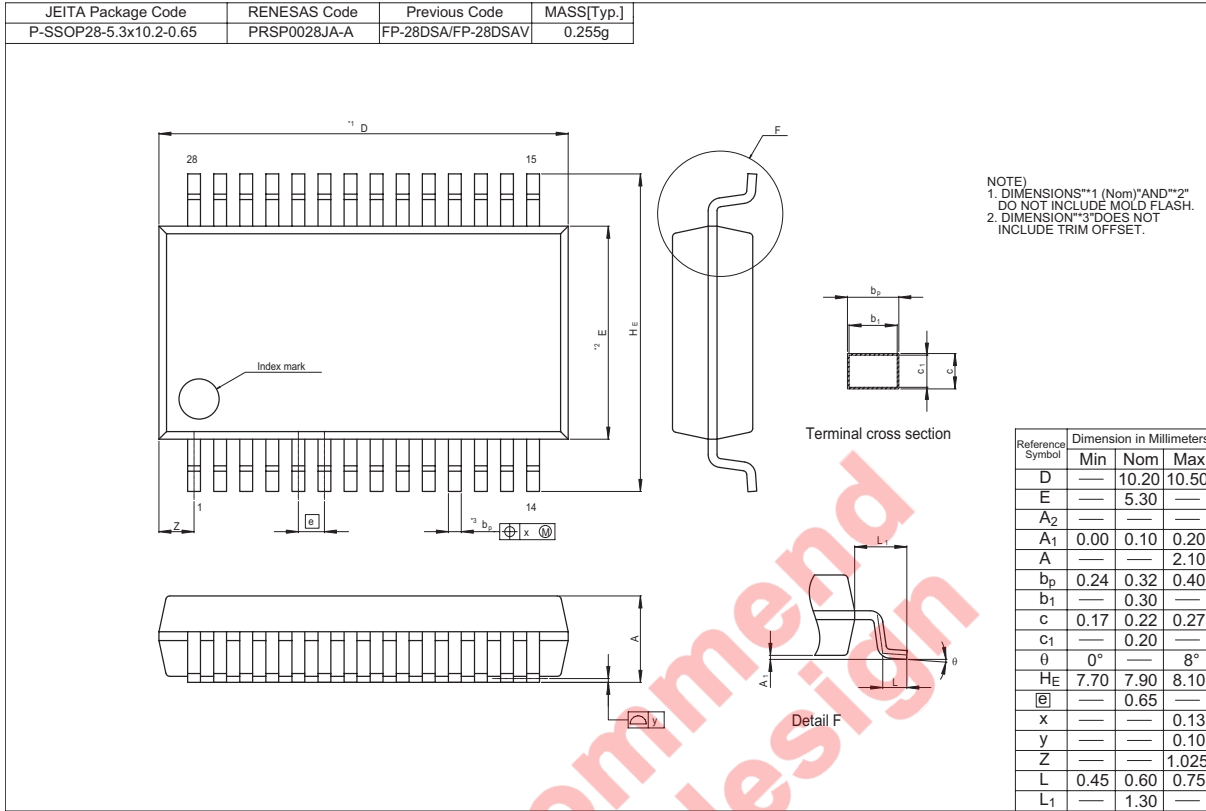

Figure 3 Output clock skew (Differential clock output)

Package Dimensions



Not recommended
 for new design

Renesas Technology Corp. Sales Strategic Planning Div. Nippon Bldg., 2-6-2, Ohte-machi, Chiyoda-ku, Tokyo 100-0004, Japan

Keep safety first in your circuit designs!

1. Renesas Technology Corp. puts the maximum effort into making semiconductor products better and more reliable, but there is always the possibility that trouble may occur with them. Trouble with semiconductors may lead to personal injury, fire or property damage.
Remember to give due consideration to safety when making your circuit designs, with appropriate measures such as (i) placement of substitutive, auxiliary circuits, (ii) use of nonflammable material or (iii) prevention against any malfunction or mishap.

Notes regarding these materials

1. These materials are intended as a reference to assist our customers in the selection of the Renesas Technology Corp. product best suited to the customer's application; they do not convey any license under any intellectual property rights, or any other rights, belonging to Renesas Technology Corp. or a third party.
2. Renesas Technology Corp. assumes no responsibility for any damage, or infringement of any third-party's rights, originating in the use of any product data, diagrams, charts, programs, algorithms, or circuit application examples contained in these materials.
3. All information contained in these materials, including product data, diagrams, charts, programs and algorithms represents information on products at the time of publication of these materials, and are subject to change by Renesas Technology Corp. without notice due to product improvements or other reasons. It is therefore recommended that customers contact Renesas Technology Corp. or an authorized Renesas Technology Corp. product distributor for the latest product information before purchasing a product listed herein.
The information described here may contain technical inaccuracies or typographical errors.
Renesas Technology Corp. assumes no responsibility for any damage, liability, or other loss rising from these inaccuracies or errors.
Please also pay attention to information published by Renesas Technology Corp. by various means, including the Renesas Technology Corp. Semiconductor home page (<http://www.renesas.com>).
4. When using any or all of the information contained in these materials, including product data, diagrams, charts, programs, and algorithms, please be sure to evaluate all information as a total system before making a final decision on the applicability of the information and products. Renesas Technology Corp. assumes no responsibility for any damage, liability or other loss resulting from the information contained herein.
5. Renesas Technology Corp. semiconductors are not designed or manufactured for use in a device or system that is used under circumstances in which human life is potentially at stake. Please contact Renesas Technology Corp. or an authorized Renesas Technology Corp. product distributor when considering the use of a product contained herein for any specific purposes, such as apparatus or systems for transportation, vehicular, medical, aerospace, nuclear, or undersea repeater use.
6. The prior written approval of Renesas Technology Corp. is necessary to reprint or reproduce in whole or in part these materials.
7. If these products or technologies are subject to the Japanese export control restrictions, they must be exported under a license from the Japanese government and cannot be imported into a country other than the approved destination.
Any diversion or reexport contrary to the export control laws and regulations of Japan and/or the country of destination is prohibited.
8. Please contact Renesas Technology Corp. for further details on these materials or the products contained therein.



RENESAS SALES OFFICES

<http://www.renesas.com>

Refer to "<http://www.renesas.com/en/network>" for the latest and detailed information.

Renesas Technology America, Inc.

450 Holger Way, San Jose, CA 95134-1368, U.S.A
Tel: <1> (408) 382-7500, Fax: <1> (408) 382-7501

Renesas Technology Europe Limited

Dukes Meadow, Millboard Road, Bourne End, Buckinghamshire, SL8 5FH, U.K.
Tel: <44> (1628) 585-100, Fax: <44> (1628) 585-900

Renesas Technology (Shanghai) Co., Ltd.

Unit 204, 205, AZIA Center, No.1233 Lujiazui Ring Rd, Pudong District, Shanghai, China 200120
Tel: <86> (21) 5877-1818, Fax: <86> (21) 6887-7898

Renesas Technology Hong Kong Ltd.

7th Floor, North Tower, World Finance Centre, Harbour City, 1 Canton Road, Tsimshatsui, Kowloon, Hong Kong
Tel: <852> 2265-6688, Fax: <852> 2730-6071

Renesas Technology Taiwan Co., Ltd.

10th Floor, No.99, Fushing North Road, Taipei, Taiwan
Tel: <886> (2) 2715-2888, Fax: <886> (2) 2713-2999

Renesas Technology Singapore Pte. Ltd.

1 Harbour Front Avenue, #06-10, Keppel Bay Tower, Singapore 098632
Tel: <65> 6213-0200, Fax: <65> 6278-8001

Renesas Technology Korea Co., Ltd.

Kukje Center Bldg. 18th Fl., 191, 2-ka, Hangang-ro, Yongsan-ku, Seoul 140-702, Korea
Tel: <82> (2) 796-3115, Fax: <82> (2) 796-2145

Renesas Technology Malaysia Sdn. Bhd

Unit 906, Block B, Menara Amcorp, Amcorp Trade Centre, No.18, Jalan Persiaran Barat, 46050 Petaling Jaya, Selangor Darul Ehsan, Malaysia
Tel: <603> 7955-9390, Fax: <603> 7955-9510