



Smallest, All-Internal MOSFET, 7-Channel 2 AA DSC PMIC

MAX8857A

General Description

The MAX8857A PMIC provides a complete power-supply solution for digital still cameras (DSCs) and digital video cameras (DVCs). The MAX8857A improves performance, component count, and board space utilization compared to currently available solutions for 2 AA cell and dual-battery designs. On-chip power MOSFETs provide up to 95% efficiency for critical power supplies. The CCD inverter can operate directly from 2 AA/NiMH batteries without the use of any additional external components.

- Step-up synchronous-rectified DC-DC converter (SU). The MAX8857A is bootstrapped from V_{SU}.
- MAIN synchronous-rectified step-up DC-DC converter (M) with active discharge for DSP I/O supply voltage.
- SDZ synchronous-rectified step-down DC-DC converter (Z) for DSP DDR supply voltage.
- Low-voltage (down to 1V) synchronous-rectified step-down DC-DC converter (SD) for DSP core supply voltage.
- Step-up DC-DC converter with current regulation and PWM dimming control (LEDBST) for up to 6 series white LEDs (WLED).
- High-voltage step-up DC-DC converter (CCDBST) for CCD imagers or positive LCD bias supplies.
- Transformerless inverting DC-DC converter (CCDINV) for CCD imagers or negative LCD bias supplies. **This converter can connect directly to 2 AA batteries.**

The MAX8857A has an independent/simultaneous power-on sequence of the CCDBST and CCDINV converters. For a preset power-on sequence of CCDBST before CCDINV, contact the factory.

The MAX8857A is available in a 5mm x 5mm, 40-pin thin QFN package and operates over the -40°C to +85°C extended temperature range.

Applications

- DSCs and DVCs
- PDA's and Portable Media Players

Ordering Information

PART	TEMP RANGE	PIN-PACKAGE	PKG CODE
MAX8857AETL+	-40°C to +85°C	40 Thin QFN-EP* 5mm x 5mm x 0.8mm	T4055-2

+Denotes a lead-free package.

*EP = Exposed paddle.

Note: Contact factory for the option where CCDBST must reach regulation before the INV converter can be turned on.



Features

- ◆ 95% Efficient Synchronous-Rectified DC-DC Converters
- ◆ 90% Efficient Boost-Buck Operation
- ◆ Up to 85% Efficient, High-Voltage DC-DC Converters
- ◆ Inverter Operates Directly from 2 AA Batteries
- ◆ Internal Compensation on All Channels
- ◆ True Shutdown™ on All Step-Up Converters
- ◆ Overload Protection
- ◆ Startup into Short Protection
- ◆ Soft-Start for Controlled Startup Current
- ◆ 100% Duty Cycle on Step-Down Converters
- ◆ Regulated Current Output for Up to 6 White LEDs
- ◆ PWM Dimming of WLED Current
- ◆ Adjustable LED Overvoltage Protection Up to 27V
- ◆ Transformerless Inverting Converter for CCD
- ◆ 2MHz ±2.5% Switching Frequency
- ◆ 1µA Shutdown Supply Current
- ◆ CCD Voltage Sequencing
- ◆ All Internal Power MOSFETs
- ◆ SDOK Power-OK Indicator

Typical Operating Circuit

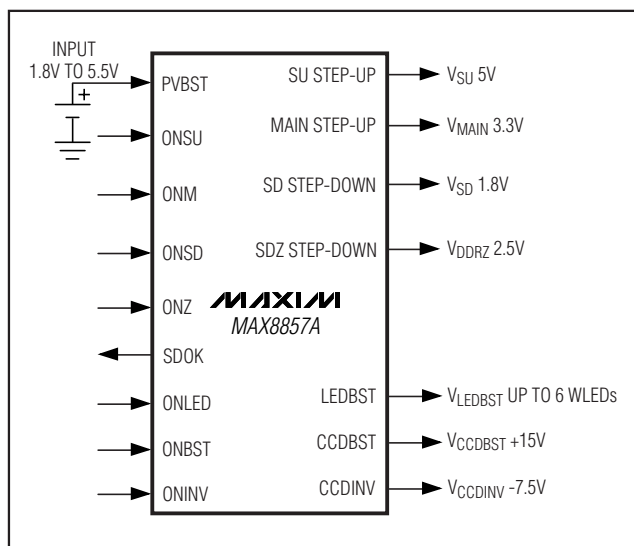

Pin Configuration appears at the end of data sheet.

True Shutdown is a trademark of Maxim Integrated Products, Inc.

For pricing, delivery, and ordering information, please contact Maxim Direct at 1-888-629-4642, or visit Maxim's website at www.maxim-ic.com.

Smallest, All-Internal MOSFET, 7-Channel 2 AA DSC PMIC

MAX8857A

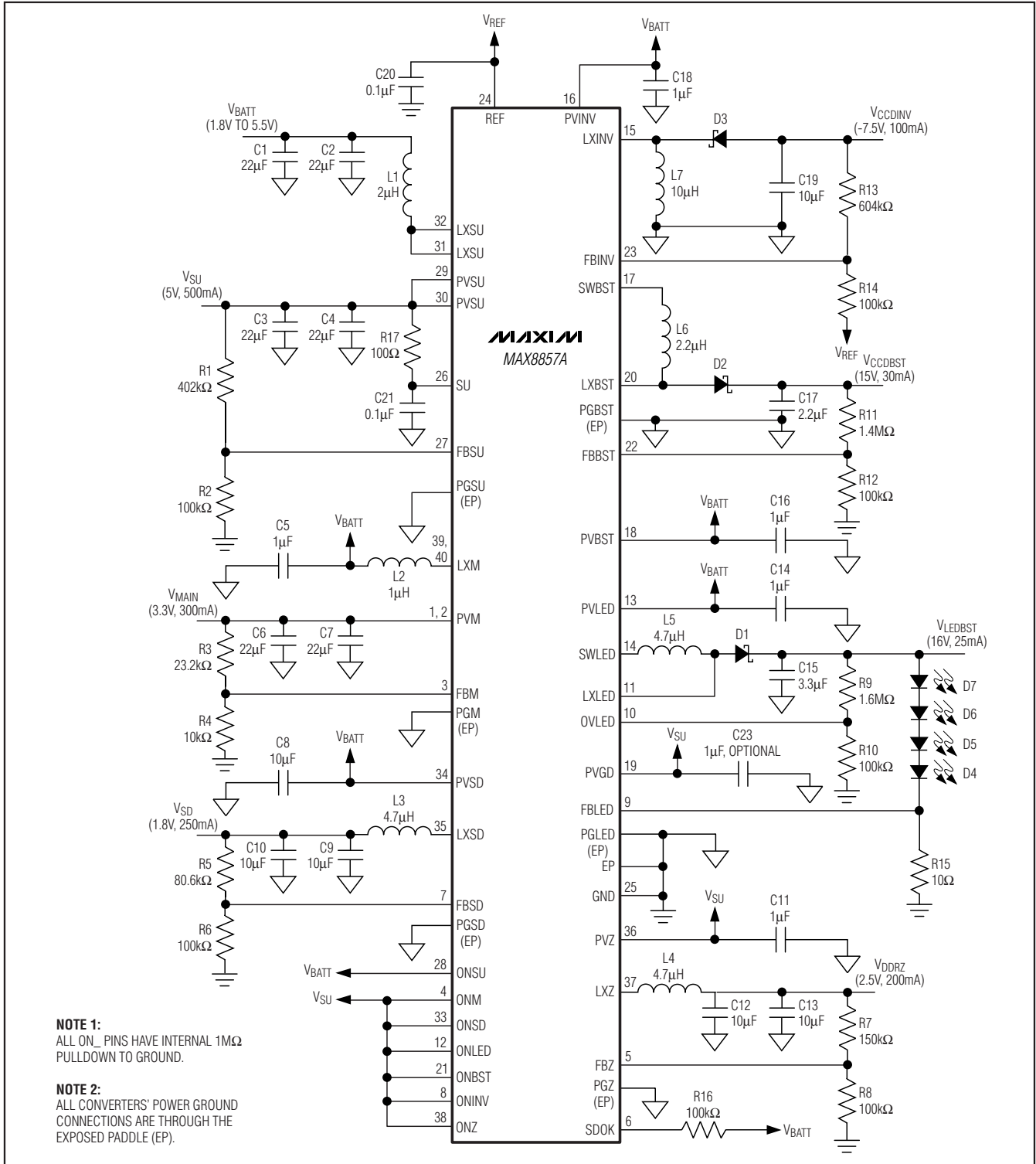

Figure 1. MAX8857A Typical Application Circuit