

TDA5703

Analog-to-Digital Converter

Preliminary Specification

Linear Products

DESCRIPTION

The TDA5703 is an 8-bit analog-to-digital converter (ADC) designed for video and professional applications. The TDA5703 converts the analog input signal into 8-bit binary-coded digital words at a sampling rate of up to 25MHz.

FEATURES

- 8-bit binary coded resolution
- Digitizing rates up to 25MHz
- Internal reference
- Only 3 external capacitors required

- Two voltage supply connections:
 - analog +5V
 - digital +5V
- 1V full-scale analog input (75Ω external resistor tied to V_{CC1})
- Full-scale bandwidth; 11MHz at 3dB
- Low power consumption; typically 250mW
- 24-lead plastic DIP

APPLICATION

- Video data conversion

ORDERING INFORMATION

DESCRIPTION	TEMPERATURE RANGE	ORDER CODE
24-Pin Plastic DIP (SOT-101 BE17)	0 to +70°C	TDA5703N

ABSOLUTE MAXIMUM RATINGS

SYMBOL	PARAMETER	RATING	UNIT
V _{CC1} V _{CC2}	Supply voltages at Pin 4 at Pin 6	8	V
V _{IN}	Input voltage at Pins 1 and 5	8	V
I _{OUT} I _O	Output current at Pins 9, 10, 11, 13, 14, 15, 16 and 17	10	mA
T _{STG}	Storage temperature range	-65 to +150	°C
T _J	Junction temperature	+125	°C
T _A	Operating ambient temperature range	0 to +70	°C

PIN CONFIGURATION

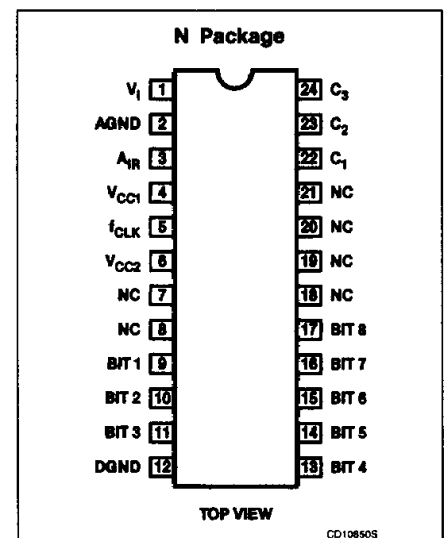

PIN NO.	SYMBOL	DESCRIPTION
1	V ₁	Analog voltage input
2	AGND	Analog ground
3	A _{1R}	Analog input reference
4	V _{CC1}	Analog supply voltage
5	f _{CLK}	Clock input
6	V _{CC2}	Digital supply voltage
7	NC	Not connected
8	NC	Not connected
9	Bit 1	Least significant bit (LSB)
10	Bit 2	
11	Bit 3	
12	DGND	Digital ground
13	Bit 4	
14	Bit 5	
15	Bit 6	
16	Bit 7	
17	Bit 8	Most significant bit (MSB)
18	NC	Not connected
19	NC	Not connected
20	NC	Not connected
21	NC	Not connected
22	C ₁	Decoupling for internal reference
23	C ₂	
24	C ₃	

Analog-to-Digital Converter

TDA5703

BLOCK DIAGRAM

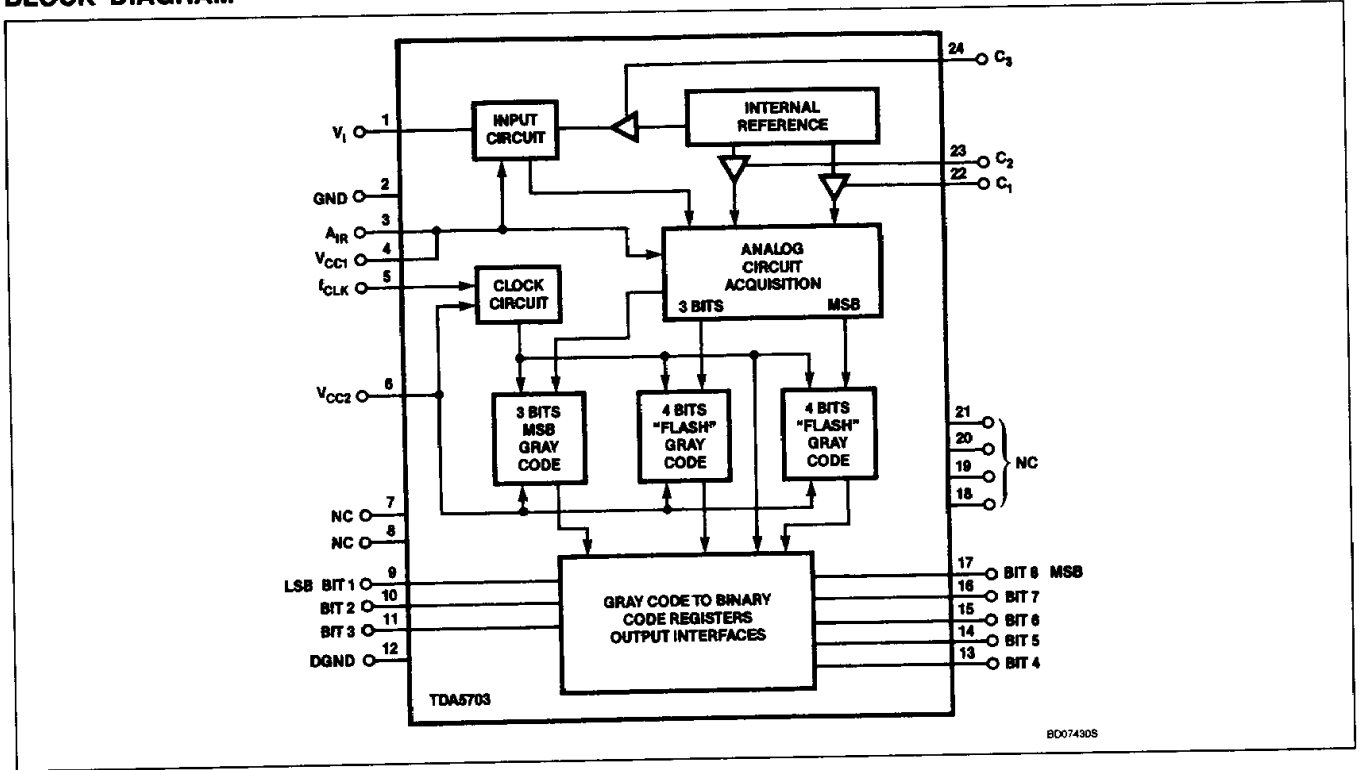

Analog-to-Digital Converter

TDA5703

DC ELECTRICAL CHARACTERISTICS $V_{CC1} = V_{CC2} = 4.75$ to $5.25V$; $T_A = 25^\circ C$, unless otherwise specified.

SYMBOL	PARAMETER	TEST CONDITIONS	LIMITS			UNIT
			Min	Typ	Max	
Supply						
V_{CC1}	Analog supply voltage	Pin 4	4.75	5.0	5.25	V
V_{CC2}	Digital supply voltage	Pin 6	4.75	5.0	5.25	V
I_{CC1}	Analog supply current	Pin 4	55	80	105	mA
I_{CC2}	Digital supply current	Pin 6	55	80	105	mA
Res	Resolution			8		bits
Digital input levels¹						
V_{IH}	Input voltage HIGH		2.2		V_{CC2}	V
V_{IL}	Input voltage LOW		-0.3		0.8	V
I_{IH}	Input current HIGH				10	μA
I_{IL}	Input current LOW		-7	350		μA
Analog input levels						
	Absolute linearity	V_1	V_{CC1}^{-1}		V_{CC1}	V
	Differential linearity	V_1	-1.5		+1.5	LSB
			-1.5		+1	LSB
BW	Bandwidth	1dB		6.0		MHz
		3dB	6.0	10		MHz
	Differential phase Differential gain	$F_0 = 25MHz$, measured with TDA5702		1 2.3		deg. %
	Offset error			40		mV
R_{IN}	Input resistance			80		$k\Omega$
C_{IN}	Input capacitance			5		pF
Digital output levels ($I_O = 10mA$)						
V_{OH}	Output voltage HIGH		2.4			V
V_{OL}	Output voltage LOW				0.40	V
C_O	External capacitance	C_1, C_2, C_3		100		nF
Temperature						
T_A	Operating ambient temperature range		0		+70	$^\circ C$

AC ELECTRICAL CHARACTERISTICS $V_{CC1} = V_{CC2} = 4.75$ to $5.25V$; $T_A = 25^\circ C$, unless otherwise specified.

SYMBOL	PARAMETER	TEST CONDITIONS	LIMITS			UNIT
			Min	Typ	Max	
Timing						
f_C	Maximum conversion rate		25	40		MHz
t_{DELAY}	Aperture delay ¹			19		ns
t_D	Digital output delay ¹			28		ns
t_{PWH}	Pulse width conversion HIGH ¹		20			ns
t_{PWL}	Pulse width conversion LOW ¹		20			ns

NOTE:

1. See Timing Diagram, Figure 1

Copyright © Each Manufacturing Company.

All Datasheets cannot be modified without permission.

This datasheet has been download from :

www.AllDataSheet.com

100% Free DataSheet Search Site.

Free Download.

No Register.

Fast Search System.

www.AllDataSheet.com