



7Ω Quad SPST Switches with Over-Rail Signal Handling

MAX4854

General Description

The MAX4854 quad single-pole/single-throw (SPST) switch operates from a single +2V to +5.5V supply and can handle signals greater than the supply rail. This switch features low 7Ω on-resistance with 30pF on-capacitance, making it ideal for switching data signals.

For over-rail applications, this device passes signals greater than the positive supply (up to +5.5V) through the switch without distortion.

The MAX4854 is available in the space-saving, 16-pin, 3mm x 3mm thin QFN package and operates over the -40°C to +85°C extended temperature range.

Features

- ◆ USB 2.0 Full Speed (12Mbps) and USB 1.1 Signal Switching
- ◆ Switches Signals Greater than V_{CC}
- ◆ 7Ω On-Resistance
- ◆ 30pF On-Capacitance
- ◆ 150MHz, -3dB Bandwidth
- ◆ 1.8V Logic Compatibility
- ◆ +2V to +5.5V Supply Range
- ◆ Low 0.01μA Supply Current
- ◆ Available in a Space-Saving, 3mm x 3mm, 16-Pin TQFN Package

Applications

- USB Switching
- Cellular Phones
- Notebook Computers
- PDA's and Other Handheld Devices

Ordering Information

PART	TEMP RANGE	PIN-PACKAGE	TOP MARK
MAX4854ETE	-40°C to +85°C	16 TQFN-EP*	ACE

*EP = Exposed paddle.

Block Diagram/Truth Table

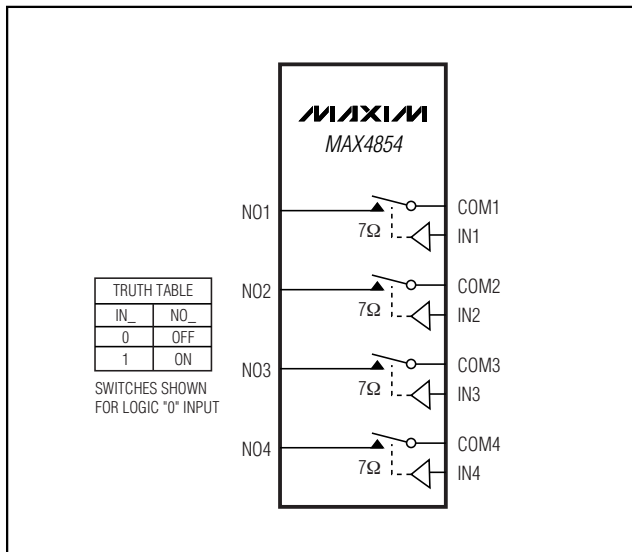

Pin Configuration

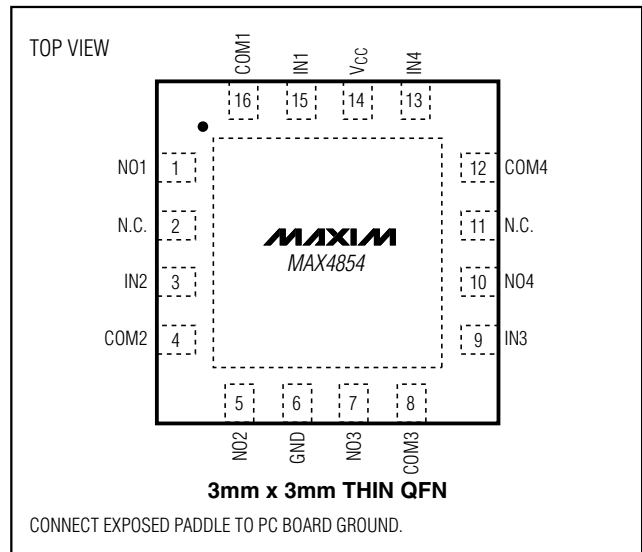

For pricing, delivery, and ordering information, please contact Maxim/Dallas Direct! at 1-888-629-4642, or visit Maxim's website at www.maxim-ic.com.

7Ω Quad SPST Switches with Over-Rail Signal Handling

ABSOLUTE MAXIMUM RATINGS

V_{CC}, IN₋, COM₋, NO₋ to GND (Note 1)-0.3V to +6.0V
 Closed-Switch Continuous Current COM₋, NO₋, NC₋±50mA
 Peak Current COM₋, NO₋
 (pulsed at 1ms, 50% duty cycle).....±100mA
 Peak Current COM₋, NO₋
 (pulsed at 1ms, 10% duty cycle).....±120mA

Continuous Power Dissipation (T_A = +70°C)
 16-Pin Thin QFN (derate 20.8mW/°C above +70°C)1667mW
 Operating Temperature Range-40°C to +85°C
 Junction Temperature+150°C
 Storage Temperature Range-65°C to +150°C
 Lead Temperature (soldering, 10s)+300°C

Note 1: Signals on IN₋, NO₋, or COM₋ below GND are clamped by internal diodes. Limit forward-diode current to maximum current rating.

Stresses beyond those listed under "Absolute Maximum Ratings" may cause permanent damage to the device. These are stress ratings only, and functional operation of the device at these or any other conditions beyond those indicated in the operational sections of the specifications is not implied. Exposure to absolute maximum rating conditions for extended periods may affect device reliability.

ELECTRICAL CHARACTERISTICS

(V_{CC} = +2.7V to +5.5V, T_A = -40°C to +85°C, unless otherwise noted. Typical values are at V_{CC} = +3.0V, T_A = +25°C, unless otherwise noted.) (Note 2)

PARAMETER	SYMBOL	CONDITIONS	MIN	TYP	MAX	UNITS
Supply Voltage	V _{CC}		2.0		5.5	V
Supply Current	I _{CC}	V _{CC} = +5.5V, V _{IN-} = 0 or V _{CC}		0.01	1	μA
ANALOG SWITCH						
Analog Signal Range	V _{NO-} , V _{COM-}		0		5.5	V
On-Resistance	R _{ON}	V _{CC} = +3V, I _{COM-} = 10mA, V _{NO-} = 0 to +5.5V	T _A = +25°C	7	9	Ω
			T _A = -40°C to +85°C		10	
On-Resistance Match Between Channels (Notes 3, 4)	ΔR _{ON}	V _{CC} = +3V, I _{COM-} = 10mA, V _{NO-} = +1.5V	T _A = +25°C	0.2	0.4	Ω
			T _A = -40°C to +85°C		0.5	
On-Resistance Flatness (Note 5)	R _{FLAT}	V _{CC} = +3V; I _{COM-} = 10mA; V _{NO-} = +1V, +2V, +3V	T _A = +25°C	2.5	3.75	Ω
			T _A = -40°C to +85°C		4.0	
NO ₋ Off-Leakage Current	I _{OFF}	V _{CC} = +5.5V, V _{NO-} = +1V or +4.5V, V _{COM-} = +4.5V or +1V	T _A = +25°C	-2	+2	nA
			T _A = -40°C to +85°C	-10	+10	
COM ₋ On-Leakage Current	I _{ON}	V _{CC} = +5.5V; V _{NO-} = +1V, +4.5V, or floating; V _{COM-} = +1V, +4.5V, or floating	T _A = +25°C	-2	+2	nA
			T _A = -40°C to +85°C	-12.5	+12.5	
DYNAMIC CHARACTERISTICS						
Skew (Note 3)	t _{SKEW}	R _S = 39Ω, C _L = 50pF, Figure 2		0.1	1	ns
Propagation Delay (Note 3)	t _{PD}	R _S = 39Ω, C _L = 50pF, Figure 2		0.9	2	ns
Turn-On Time	t _{ON}	V _{CC} = +3V, V _{NO-} = +1.5V, R _L = 300Ω, C _L = 50pF, Figure 1	T _A = +25°C	40	60	ns
			T _A = -40°C to +85°C		100	
Turn-Off Time	t _{OFF}	V _{CC} = +3V, V _{NO-} = +1.5V, R _L = 300Ω, C _L = 50pF, Figure 1	T _A = +25°C	30	40	ns
			T _A = -40°C to +85°C		60	
Charge Injection	Q	V _{COM-} = +1.5V, R _S = 0Ω, C _L = 1nF, Figure 3		8		pC
Off-Isolation (Note 6)		f = 100kHz, V _{COM-} = 1V _{RMS} , R _L = 50Ω, C _L = 5pF, Figure 4		-80		dB
Crosstalk		f = 1MHz, V _{COM-} = 1V _{RMS} , R _L = 50Ω, C _L = 5pF, Figure 4		-95		dB
-3dB Bandwidth	BW	Signal = 0dBm, R _L = 50Ω, C _L = 5pF, Figure 4		150		MHz

7Ω Quad SPST Switches with Over-Rail Signal Handling

ELECTRICAL CHARACTERISTICS (continued)

(V_{CC} = +2.7V to +5.5V, T_A = -40°C to +85°C, unless otherwise noted. Typical values are at V_{CC} = +3.0V, T_A = +25°C, unless otherwise noted.) (Note 2)

PARAMETER	SYMBOL	CONDITIONS	MIN	TYP	MAX	UNITS
NO_ Off-Capacitance	C _{OFF}	f = 1MHz, Figure 5		13		pF
COM On-Capacitance	C _{ON}	f = 1MHz, Figure 5		30		pF
Total Harmonic Distortion	THD	f = 20Hz to 20kHz, V _{COM_} = 1V +2V _{P-P} , R _L = 600Ω		0.04		%
DIGITAL I/O (IN_)						
Input Logic High Voltage	V _{IH}	V _{CC} = +2V to +3.6V	1.4			V
		V _{CC} = +3.6V to +5.5V	1.8			
Input Logic Low Voltage	V _{IL}	V _{CC} = +2V to +3.6V			0.5	V
		V _{CC} = +3.6V to +5.5V			0.8	
Input Leakage	I _{IN}	V _{IN_} = 0 or +5.5V	-0.5		+0.5	μA

Note 2: Specifications are 100% tested at T_A = +85°C only, and guaranteed by design and characterization over the specified temperature range.

Note 3: Guaranteed by design and characterization; not production tested.

Note 4: ΔR_{ON} = R_{ON(MAX)} - R_{ON(MIN)}.

Note 5: Flatness is defined as the difference between the maximum and minimum value of on-resistance as measured over the specified analog signal ranges.

Note 6: Off-isolation = 20log₁₀ (V_{COM_} / V_{NO_}), V_{COM_} = output, V_{NO_} = input to off switch.

Typical Operating Characteristics

(V_{CC} = 3.0V, T_A = +25°C, unless otherwise noted.)

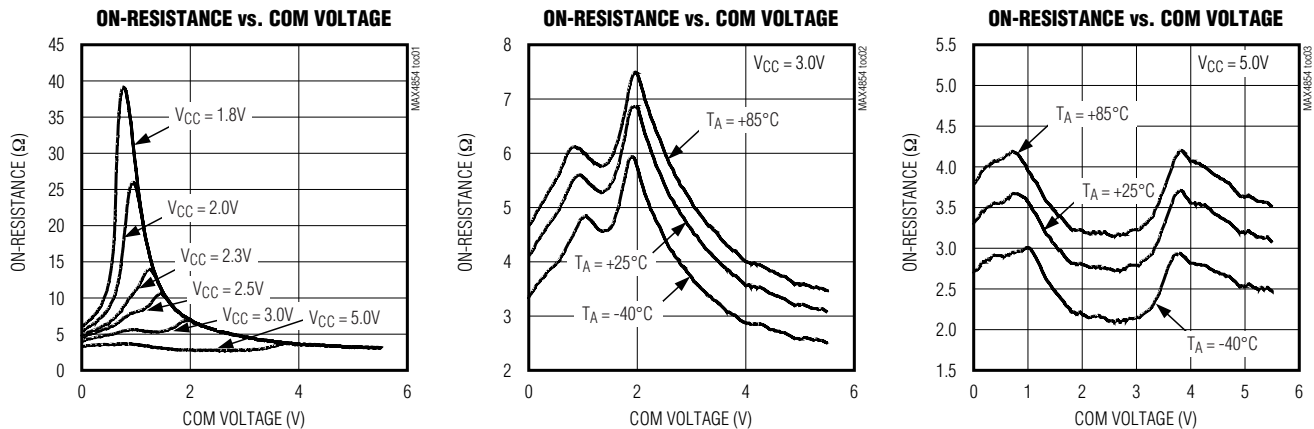

7Ω Quad SPST Switches with Over-Rail Signal Handling

Typical Operating Characteristics (continued)

($V_{CC} = 3.0V$, $T_A = +25^\circ C$, unless otherwise noted.)

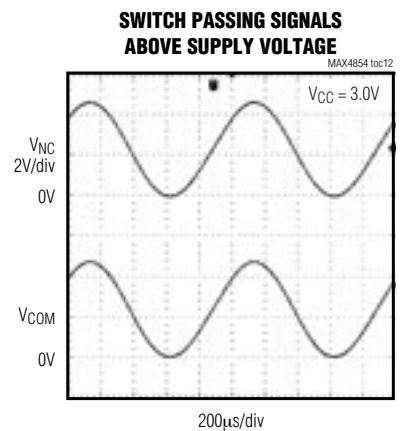
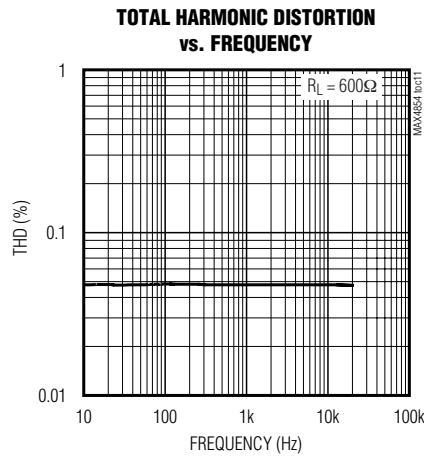
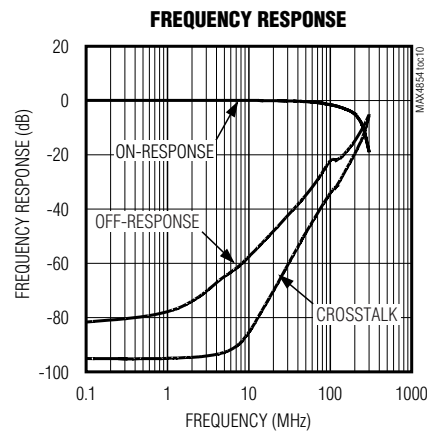
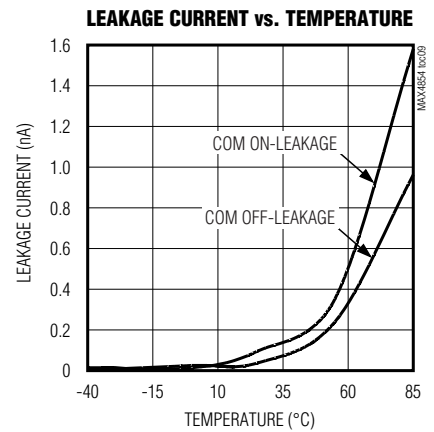
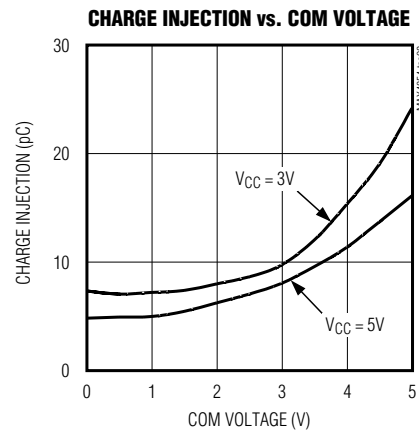
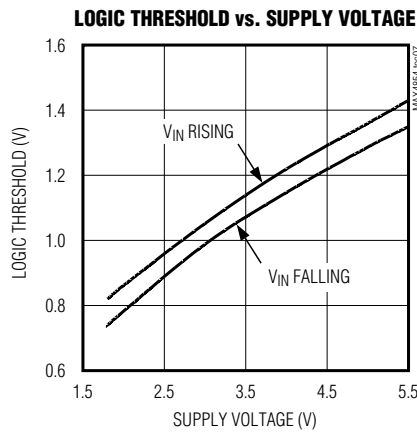
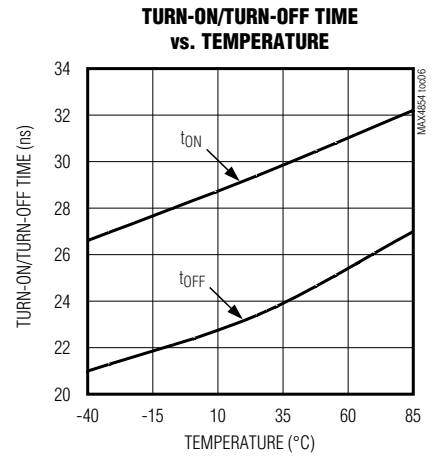
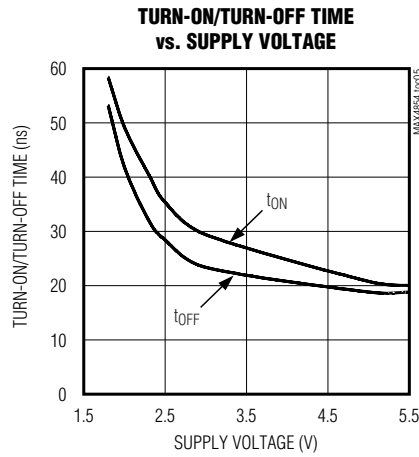
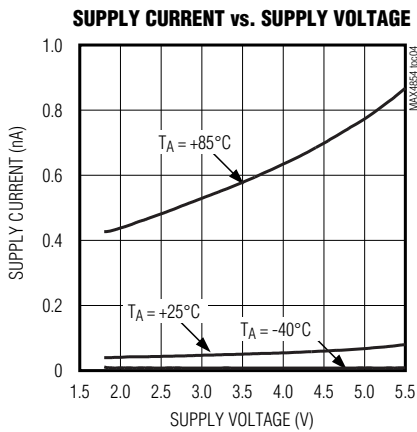

7Ω Quad SPST Switches with Over-Rail Signal Handling

Pin Description

MAX4854

PIN	NAME	FUNCTION
1	NO1	Normally Open Terminal for Analog Switch 1
2, 11	N.C.	No Connection. Not internally connected.
3	IN2	Digital Control Input for Analog Switch 2. A logic-low on IN2 disconnects COM2 from NO2 and a logic-high connects COM2 to NO2.
4	COM2	Common Terminal for Analog Switch 2
5	NO2	Normally Open Terminal for Analog Switch 2
6	GND	Ground
7	NO3	Normally Open Terminal for Analog Switch 3
8	COM3	Common Terminal for Analog Switch 3
9	IN3	Digital Control Input for Analog Switch 3. A logic-low on IN3 disconnects COM3 from NO3 and a logic-high connects COM3 to NO3.
10	NO4	Normally Open Terminal for Analog Switch 4
12	COM4	Common Terminal for Analog Switch 4
13	IN4	Digital Control Input for Analog Switch 4. A logic-low on IN4 disconnects COM4 from NO4 and a logic-high connects COM4 to NO4.
14	VCC	Supply Voltage. Bypass to GND with a 0.01μF capacitor as close to the pin as possible.
15	IN1	Digital Control Input for Analog Switch 1. A logic-low on IN1 disconnects COM1 from NO1 and a logic-high connects COM1 to NO1.
16	COM1	Common Terminal for Analog Switch 1
EP	GND	Exposed Pad. Connect to ground.

7Ω Quad SPST Switches with Over-Rail Signal Handling

Detailed Description

The MAX4854 low on-resistance, low-voltage, analog switch is designed to operate from a +2V to +5.5V single supply and is fully specified for nominal +3.0V applications. The device features over-rail signal capability that allows signals up to +5.5V with supply voltages down to +2.0V to pass through without distortion.

This quad SPST switch has low on-channel capacitance, which allows switching of the data signals for USB 2.0/1.1 applications (12Mbps). It is designed to switch D+ and D- USB signals with a guaranteed skew of less than 1ns (see Figure 2) as measured from 50% of the input signal to 50% of the output signal.

Applications Information

Digital Control Inputs

The logic inputs (IN_n) accept up to +5.5V even if the supply voltages are below this level. For example, with a +3.3V V_{CC} supply, IN_n can be driven low to GND and high to +5.5V, allowing for mixing of logic levels in a system. Driving IN_n rail-to-rail minimizes power consumption. For a +2V supply voltage, the logic thresholds are +0.5V (low) and +1.4V (high); for a +5V supply voltage, the logic thresholds are +0.8V (low) and +1.8V (high).

Analog Signal Levels

The on-resistance of these switches changes very little for analog input signals across the entire supply voltage range (see the *Typical Operating Characteristics*). The switches are bidirectional; therefore, NO_n and COM_n can be either inputs or outputs.

Power-Supply Sequencing

Caution: Do not exceed the absolute maximum ratings because stresses beyond the listed ratings may cause permanent damage to the device.

Proper power-supply sequencing is recommended for all CMOS devices. Always apply V_{CC} before applying analog signals, especially if the analog signal is not current limited.

Typical Operating Circuit

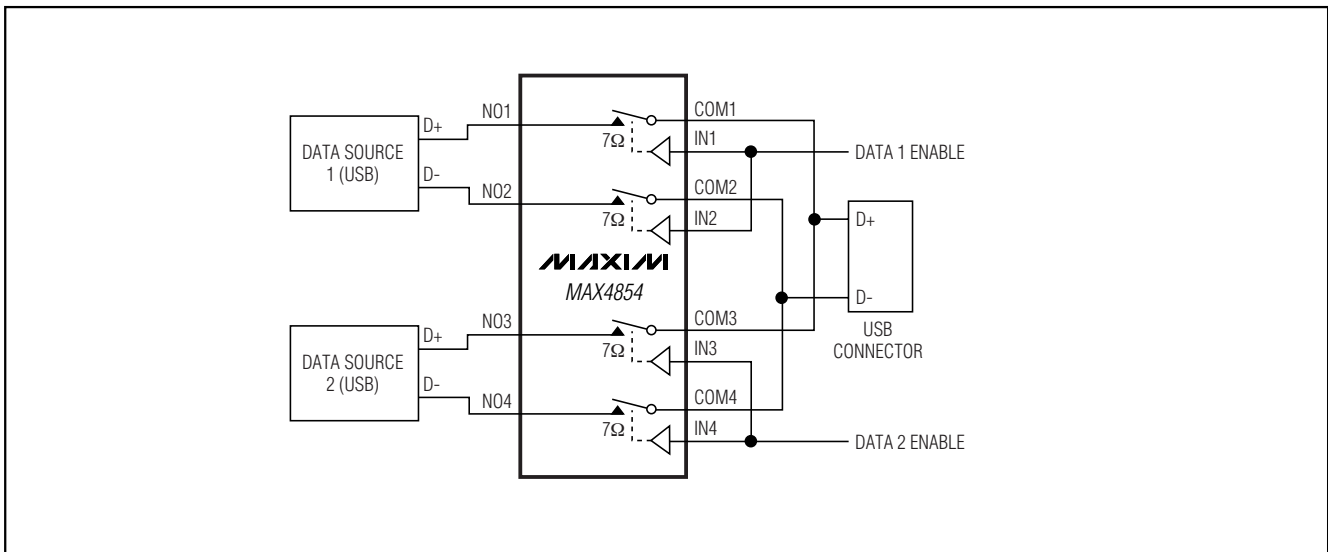

7Ω Quad SPST Switches with Over-Rail Signal Handling

Test Circuits/Timing Diagrams

MAX4854

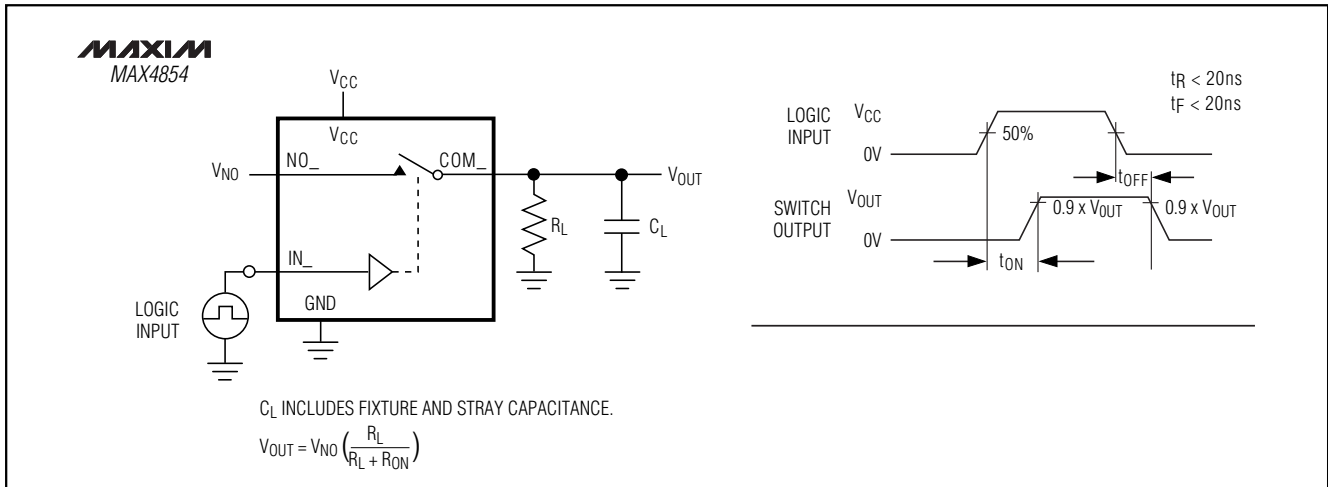

Figure 1. Switching Time

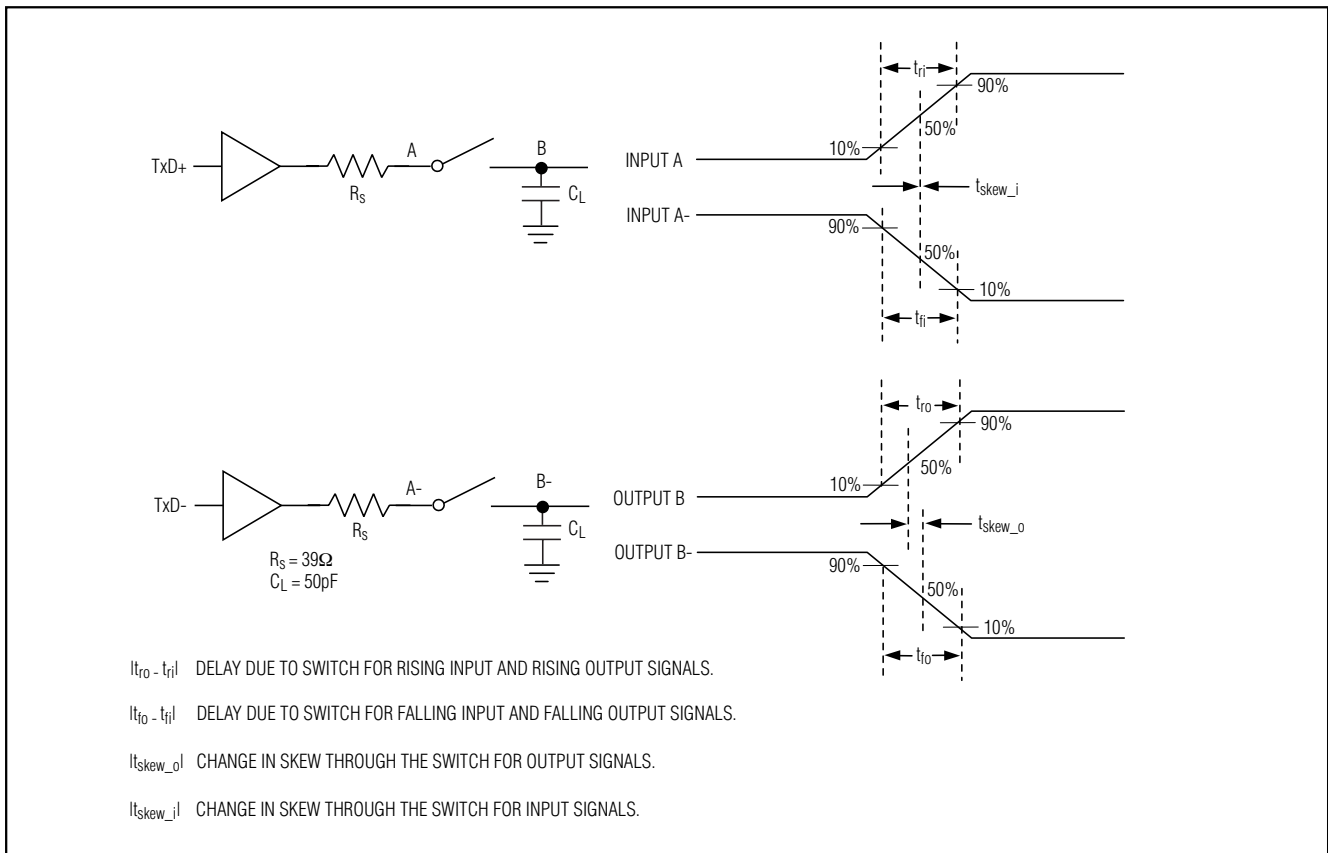

Figure 2. Input/Output Skew Timing Diagram

7Ω Quad SPST Switches with Over-Rail Signal Handling

Test Circuits/Timing Diagrams (continued)

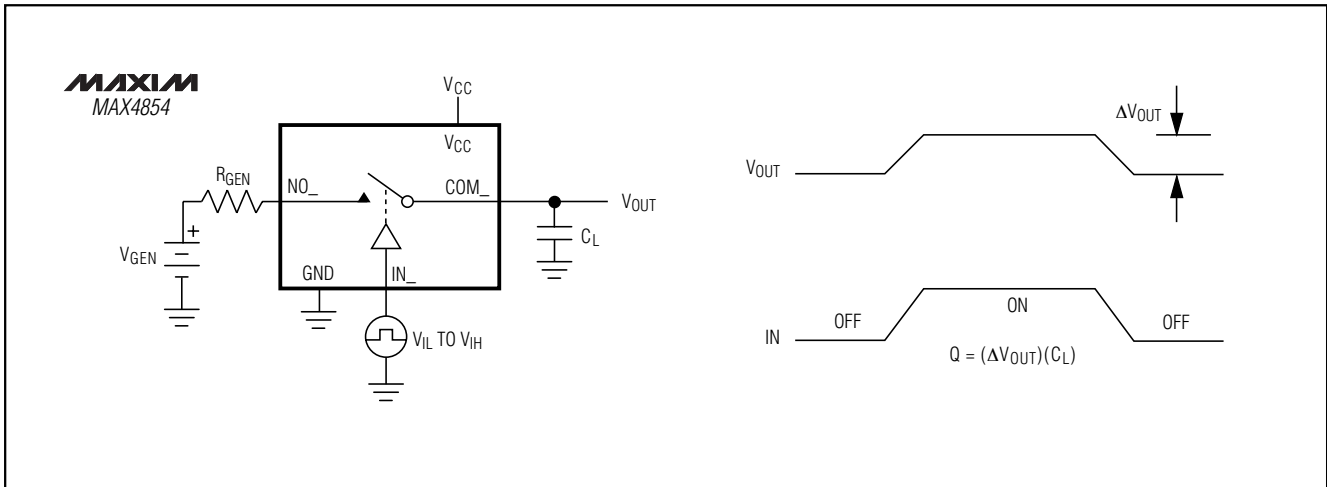

Figure 3. Charge Injection

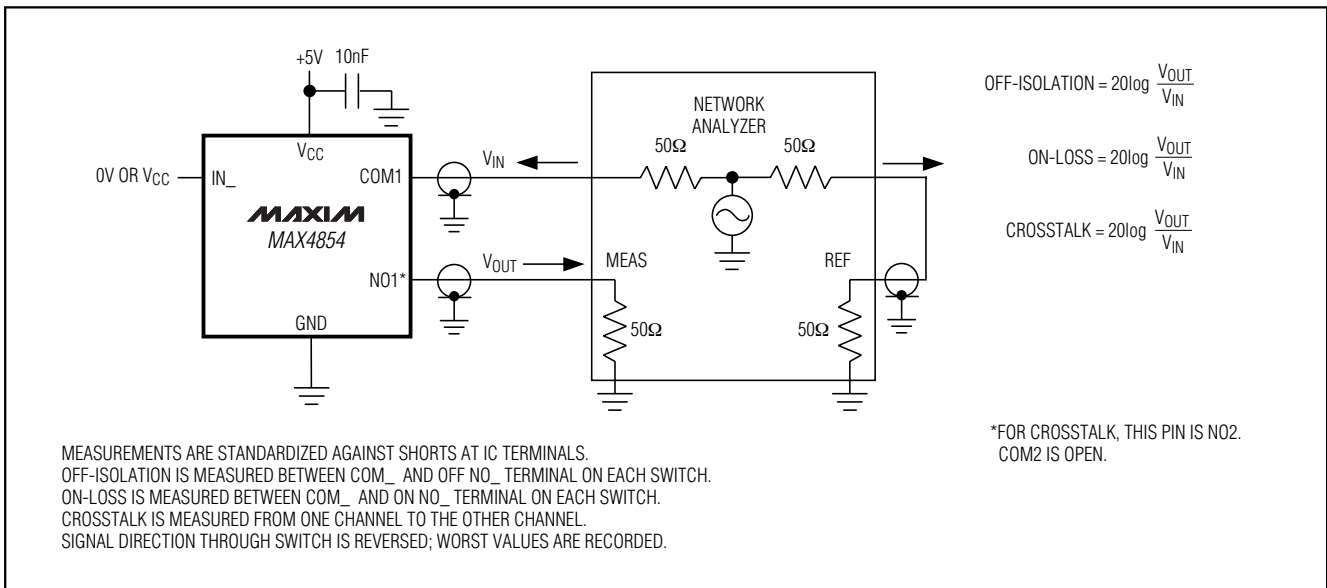

Figure 4. On-Loss, Off-Isolation, and Crosstalk

7Ω Quad SPST Switches with Over-Rail Signal Handling

MAX4854

**Test Circuits/
Timing Diagrams (continued)**

Chip Information

TRANSISTOR COUNT: 735
PROCESS: CMOS

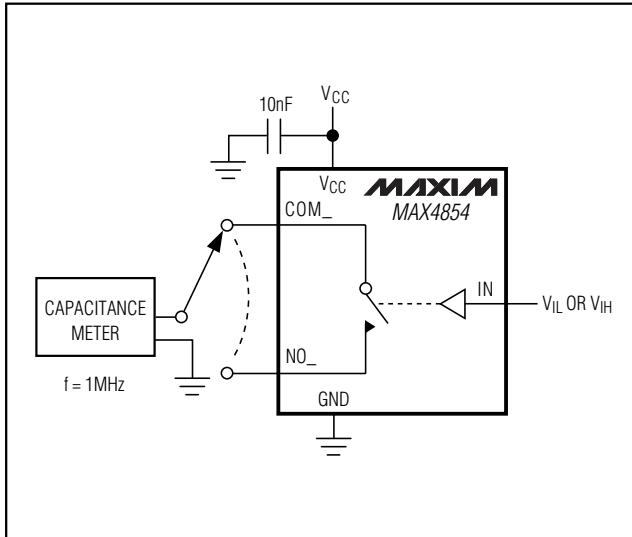

Figure 5. Channel Off-/On-Capacitance

7Ω Quad SPST Switches with Over-Rail Signal Handling

Package Information (continued)

(The package drawing(s) in this data sheet may not reflect the most current specifications. For the latest package outline information, go to www.maxim-ic.com/packages.)

MAX4854

PKG REF.	12L 3x3			16L 3x3		
	MIN.	NOM.	MAX.	MIN.	NOM.	MAX.
A	0.70	0.75	0.80	0.70	0.75	0.80
b	0.20	0.25	0.30	0.20	0.25	0.30
D	2.90	3.00	3.10	2.90	3.00	3.10
E	2.90	3.00	3.10	2.90	3.00	3.10
e	0.50 BSC.			0.50 BSC.		
L	0.45	0.55	0.65	0.30	0.40	0.50
N	12			16		
ND	3			4		
NE	3			4		
A1	0	0.02	0.05	0	0.02	0.05
A2	0.20 REF			0.20 REF		
k	0.25	-	-	0.25	-	-

PKG CODES	EXPOSED PAD VARIATIONS						PIN ID	JEDEC	DOWN BONDS ALLOWED
	D2			E2					
	MIN.	NOM.	MAX.	MIN.	NOM.	MAX.			
T1233-1	0.95	1.10	1.25	0.95	1.10	1.25	0.35 x 45°	WEED-1	NO
T1233-3	0.95	1.10	1.25	0.95	1.10	1.25	0.35 x 45°	WEED-1	YES
T1633-1	0.95	1.10	1.25	0.95	1.10	1.25	0.35 x 45°	WEED-2	NO
T1633-2	0.95	1.10	1.25	0.95	1.10	1.25	0.35 x 45°	WEED-2	YES
T1633F-3	0.85	0.80	0.85	0.85	0.80	0.95	0.225 x 45°	WEED-2	N/A
T1633-4	0.95	1.10	1.25	0.95	1.10	1.25	0.35 x 45°	WEED-2	NO

NOTES:

- DIMENSIONING & TOLERANCING CONFORM TO ASME Y14.5M-1994.
- ALL DIMENSIONS ARE IN MILLIMETERS. ANGLES ARE IN DEGREES.
- N IS THE TOTAL NUMBER OF TERMINALS.
- △ THE TERMINAL #1 IDENTIFIER AND TERMINAL NUMBERING CONVENTION SHALL CONFORM TO JESD 95-1 SPP-012. DETAILS OF TERMINAL #1 IDENTIFIER ARE OPTIONAL, BUT MUST BE LOCATED WITHIN THE ZONE INDICATED. THE TERMINAL #1 IDENTIFIER MAY BE EITHER A MOLD OR MARKED FEATURE.
- △ DIMENSION b APPLIES TO METALLIZED TERMINAL AND IS MEASURED BETWEEN 0.20 mm AND 0.25 mm FROM TERMINAL TIP.
- △ ND AND NE REFER TO THE NUMBER OF TERMINALS ON EACH D AND E SIDE RESPECTIVELY.
- DEPOPULATION IS POSSIBLE IN A SYMMETRICAL FASHION.
- △ COPLANARITY APPLIES TO THE EXPOSED HEAT SINK SLUG AS WELL AS THE TERMINALS.
- DRAWING CONFORMS TO JEDEC MO220 REVISION C.

DALLAS SEMICONDUCTOR		MAXIM	
<small>PROPRIETARY INFORMATION</small>			
<small>TITLE: PACKAGE OUTLINE 12, 16L, THIN QFN, 3x3x0.8mm</small>			
<small>APPROVAL</small>	<small>DOCUMENT CONTROL NO.</small> 21-0136	<small>REV.</small> E	<small>2/2</small>

Maxim cannot assume responsibility for use of any circuitry other than circuitry entirely embodied in a Maxim product. No circuit patent licenses are implied. Maxim reserves the right to change the circuitry and specifications without notice at any time.

Maxim Integrated Products, 120 San Gabriel Drive, Sunnyvale, CA 94086 408-737-7600 _____ 11