

74ABT16244A

16-bit buffer/line driver; 3-state

Rev. 06 — 23 March 2009

Product data sheet

1. General description

The 74ABT16244A high-performance Bipolar CMOS (BiCMOS) device combines low static and dynamic power dissipation with high speed and high output drive.

The 74ABT16244A is a 16-bit buffer that is ideal for driving bus lines. The device features four output enable inputs ($1\overline{OE}$, $2\overline{OE}$, $3\overline{OE}$, $4\overline{OE}$), each controlling four of the 3-state outputs.

2. Features

- 16-bit bus interface
- Multiple V_{CC} and GND pins minimize switching noise
- Power-up 3-state
- 3-state buffers
- Output capability: +64 mA and -32 mA
- Live insertion and extraction permitted
- Latch-up performance: JESD 78 Class II
- ESD protection:
 - ◆ MIL STD 883 method 3015: exceeds 2000 V
 - ◆ CDM JESD 22-C101-C exceeds 1000 V

3. Ordering information

Table 1. Ordering information

Type number	Package			
	Temperature range	Name	Description	Version
74ABT16244ADGG	-40 °C to +85 °C	TSSOP48	plastic thin shrink small outline package; 48 leads; body width 6.1 mm	SOT362-1
74ABT16244ADL	-40 °C to +85 °C	SSOP48	plastic shrink small outline package; 48 leads; body width 7.5 mm	SOT370-1



4. Functional diagram

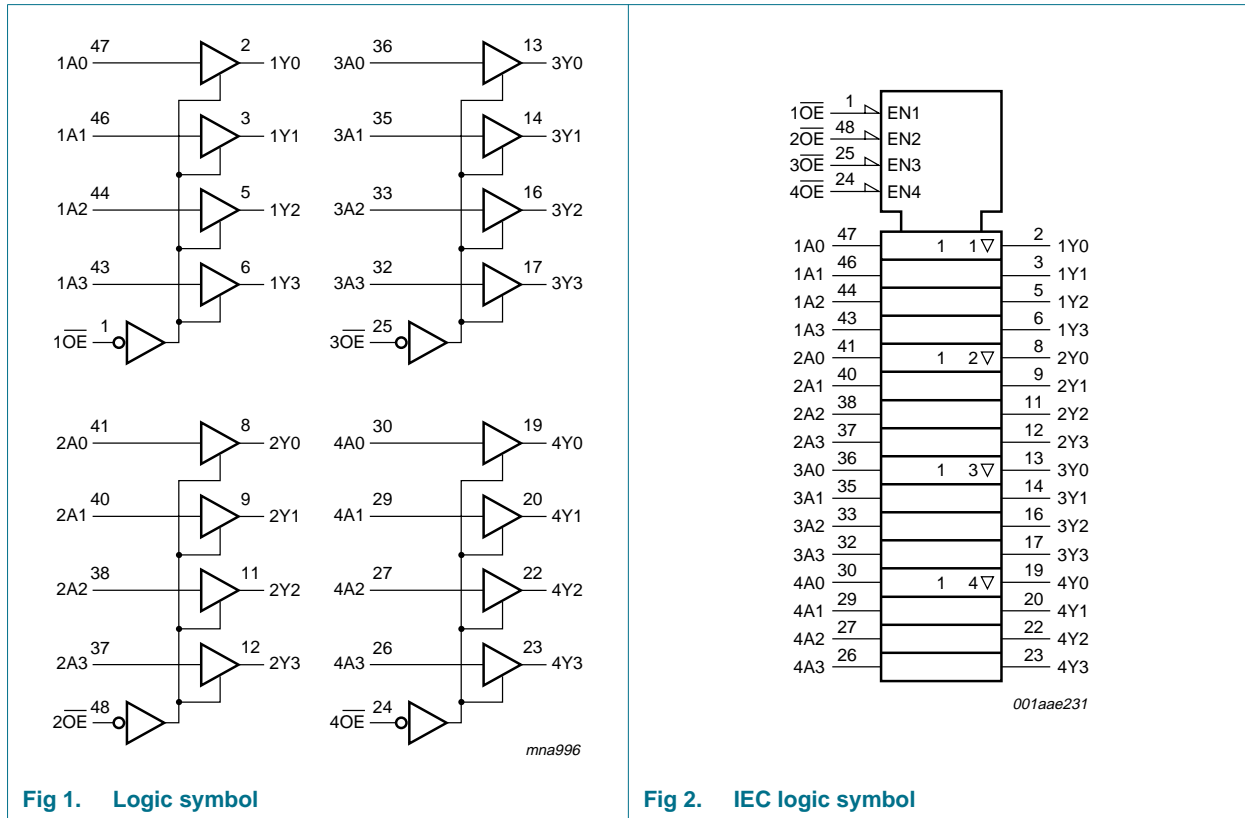

5. Pinning information

5.1 Pinning

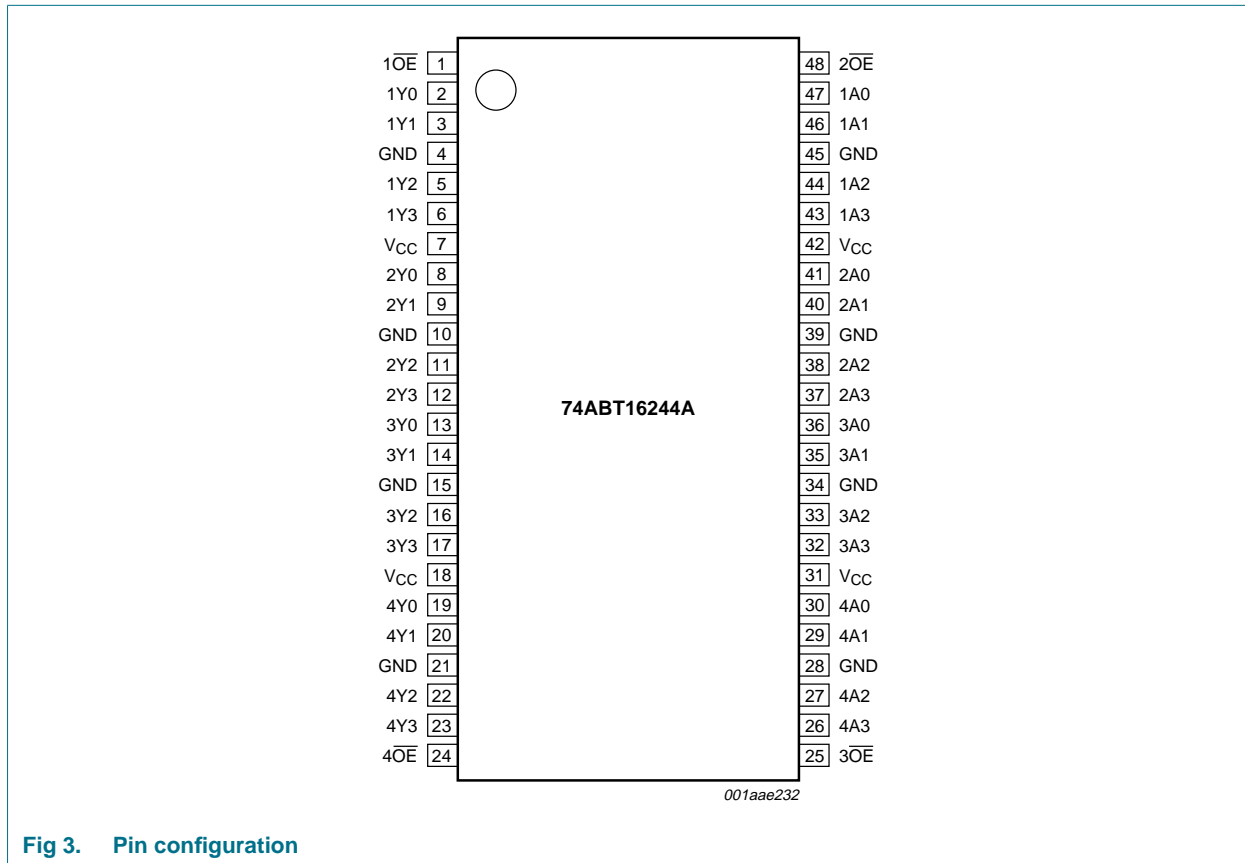

Fig 3. Pin configuration

5.2 Pin description

Table 2. Pin description

Symbol	Pin	Description
1OE	1	1 output enable (LOW active)
1Y[0:3]	2, 3, 5, 6	1 data output 0 to output 3
GND	4	ground (0 V)
V _{CC}	7	supply voltage
2Y[0:3]	8, 9, 11, 12	2 data output 0 to output 3
GND	10	ground (0 V)
3Y[0:3]	13, 14, 16, 17	3 data output 0 to output 3
GND	15	ground (0 V)
V _{CC}	18	supply voltage
4Y[0:3]	19, 20, 22, 23	4 data output 0 to output 3
GND	21	ground (0 V)

Table 2. Pin description ...continued

Symbol	Pin	Description
4 \overline{OE}	24	4 output enable (LOW active)
3 \overline{OE}	25	3 output enable (LOW active)
GND	28	ground (0 V)
4A[0:3]	30, 29, 27, 26	4 data input 0 to input 3
V _{CC}	31	supply voltage
GND	34	ground (0 V)
3A[0:3]	36, 35, 33, 32	3 data input 0 to input 3
GND	39	ground (0 V)
2A[0:3]	41, 40, 38, 37	2 data input 0 to input 3
V _{CC}	42	supply voltage
GND	45	ground (0 V)
1A[0:3]	47, 46, 44, 43	1 data input 0 to input 3
2 \overline{OE}	48	2 output enable (LOW active)

6. Functional description

Table 3. Function table^[1]

Control	Input	Output
$n\overline{OE}$	nAx	nYx
L	L	L
	H	H
H	X	Z

- [1] H = HIGH voltage level;
 L = LOW voltage level;
 X = don't care;
 Z = high-impedance OFF-state.

7. Limiting values

Table 4. Limiting values

In accordance with the Absolute Maximum Rating System (IEC 60134).

Symbol	Parameter	Conditions	Min	Max	Unit
V _{CC}	supply voltage		-0.5	+7.0	V
V _I	input voltage		^[1] -1.2	+7.0	V
V _O	output voltage	output in OFF-state or HIGH-state	^[1] -0.5	+5.5	V
I _{IK}	input clamping current	V _I < 0 V	-18	-	mA
I _{OK}	output clamping current	V _O < 0 V	-50	-	mA
I _O	output current	output in LOW-state	-	128	mA
		output in HIGH-state	-	-64	mA
T _j	junction temperature		^[2] -	150	°C
T _{stg}	storage temperature		-65	+150	°C

- [1] The input and output voltage ratings may be exceeded if the input and output current ratings are observed.
- [2] The performance capability of a high-performance integrated circuit in conjunction with its thermal environment can create junction temperatures which are detrimental to reliability.

8. Recommended operating conditions

Table 5. Operating conditions
 Voltages are referenced to GND (ground = 0 V).

Symbol	Parameter	Conditions	Min	Typ	Max	Unit
V _{CC}	supply voltage		4.5	-	5.5	V
V _I	input voltage		0	-	V _{CC}	V
V _{IH}	HIGH-level input voltage		2.0	-	-	V
V _{IL}	LOW-level Input voltage		-	-	0.8	V
I _{OH}	HIGH-level output current		-32	-	-	mA
I _{OL}	LOW-level output current		-	-	64	mA
Δt/ΔV	input transition rise or fall rate		-	-	10	ns/V
T _{amb}	ambient temperature	in free air	-40	-	+85	°C

9. Static characteristics

Table 6. Static characteristics

Symbol	Parameter	Conditions	25 °C			-40 °C to +85 °C		Unit	
			Min	Typ	Max	Min	Max		
V _{IK}	input clamping voltage	V _{CC} = 4.5 V; I _{IK} = -18 mA	-	-0.9	-1.2	-	-1.2	V	
V _{OH}	HIGH-level output voltage	V _I = V _{IL} or V _{IH}							
		V _{CC} = 4.5 V; I _{OH} = -3 mA	2.5	2.9	-	2.5	-	V	
		V _{CC} = 5.0 V; I _{OH} = -3 mA	3.0	3.4	-	3.0	-	V	
		V _{CC} = 4.5 V; I _{OH} = -32 mA	2.0	2.4	-	2.0	-	V	
V _{OL}	LOW-level output voltage	V _{CC} = 4.5 V; I _{OL} = 64 mA; V _I = V _{IL} or V _{IH}	-	0.42	0.55	-	0.55	V	
I _I	input leakage current	V _{CC} = 5.5 V; V _I = GND or 5.5 V	-	±0.01	±1.0	-	±1.0	μA	
I _{OFF}	power-off leakage current	V _{CC} = 0 V; V _I or V _O ≤ 4.5 V	-	±5.0	±100	-	±100	μA	
I _{O(pu/pd)}	power-up/power-down output current	V _{CC} = 2.0 V; V _O = 0.5 V; V _I = GND or V _{CC} ; nOE = V _{CC}	[1]	-	±5.0	±50	-	±50	μA
I _{OZ}	OFF-state output current	V _{CC} = 5.5 V; V _I = V _{IL} or V _{IH}							
		output HIGH-state at V _O = 5.5 V	-	0.1	10	-	10	μA	
		output LOW-state at V _O = 0 V	-	-0.1	-10	-	-10	μA	
I _{LO}	output leakage current	HIGH-state; V _O = 5.5 V; V _{CC} = 5.5 V; V _I = GND or V _{CC}	-	5.0	50	-	50	μA	
I _O	output current	V _{CC} = 5.5 V; V _O = 2.5 V	[2]	-50	-100	-180	-50	-180	mA
I _{CC}	supply current	V _{CC} = 5.5 V; V _I = GND or V _{CC}							
		outputs HIGH-state	-	0.45	1.0	-	1.0	mA	
		outputs LOW-state	-	10	19	-	19	mA	
		outputs 3-state	-	0.45	1.0	-	1.0	mA	

Table 6. Static characteristics ...continued

Symbol	Parameter	Conditions	25 °C			-40 °C to +85 °C		Unit
			Min	Typ	Max	Min	Max	
ΔI_{CC}	additional supply current	per input pin; $V_{CC} = 5.5$ V; one input at 3.4 V and other inputs at V_{CC} or GND ^{[1][3]}	-	100	250	-	250	μ A
C_I	input capacitance	$V_I = 0$ V or V_{CC}	-	4	-	-	-	pF
$C_{I/O}$	I/O capacitance	outputs disabled; $V_O = 0$ V or V_{CC}	-	7	-	-	-	pF

[1] This is the increase in supply current for each input at 3.4 V.

[2] Not more than one output should be tested at a time, and the duration of the test should not exceed one second.

[3] This data sheet limit may vary among suppliers.

10. Dynamic characteristics

Table 7. Dynamic characteristics

$GND = 0$ V. For test circuit, see [Figure 6](#).

Symbol	Parameter	Conditions	25 °C; $V_{CC} = 5.0$ V			-40 °C to +85 °C; $V_{CC} = 5.0$ V \pm 0.5 V		Unit
			Min	Typ	Max	Min	Max	
t_{PLH}	LOW to HIGH propagation delay	nAx to nYx, see Figure 4	1.1	1.7	2.6	1.1	2.8	ns
t_{PHL}	HIGH to LOW propagation delay	nAx to nYx, see Figure 4	1.3	2.1	2.9	1.3	3.4	ns
t_{PZH}	OFF-state to HIGH propagation delay	\overline{nOE} to nYx; see Figure 5	1.6	2.7	3.7	1.6	4.5	ns
t_{PZL}	OFF-state to LOW propagation delay	\overline{nOE} to nYx; see Figure 5	2.3	3.5	4.0	2.3	4.8	ns
t_{PHZ}	HIGH to OFF-state propagation delay	\overline{nOE} to nYx; see Figure 5	1.5	3.0	4.0	1.5	4.6	ns
t_{PLZ}	LOW to OFF-state propagation delay	\overline{nOE} to nYx; see Figure 5	1.6	2.4	3.2	1.6	4.1	ns

11. Waveforms

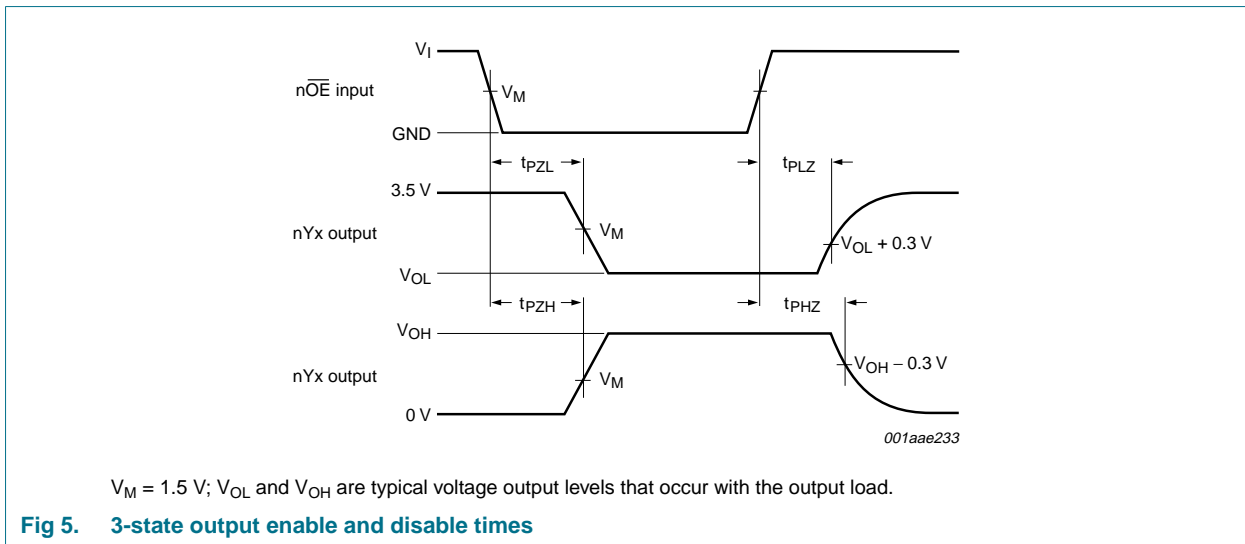
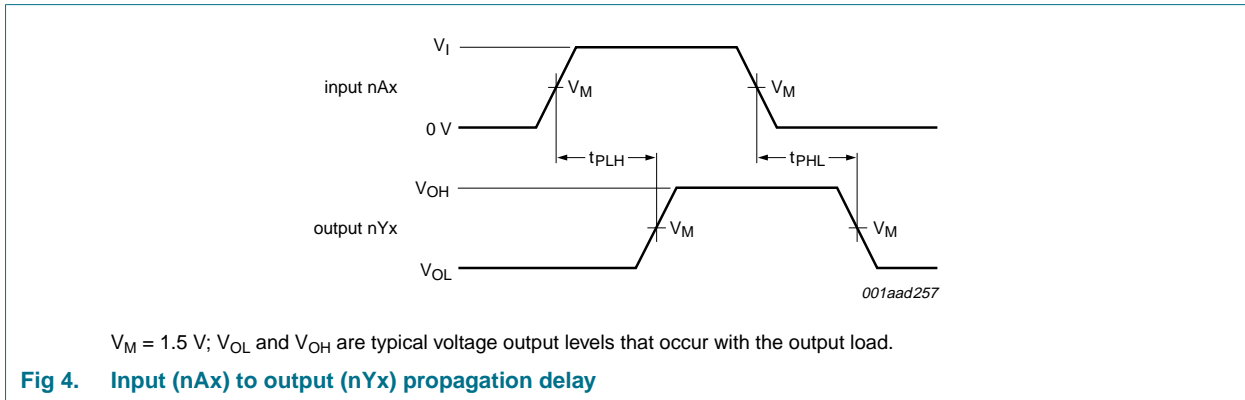

12. Test information

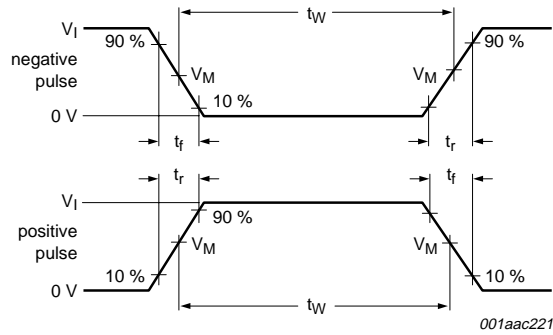

$V_M = 1.5\text{ V}$.

a. Input pulse definition

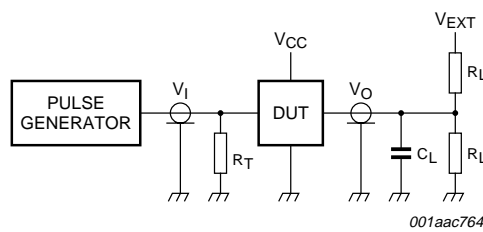

Test data is given in [Table 8](#).

Definitions test circuit:

R_L = Load resistance.

C_L = Load capacitance including jig and probe capacitance.

R_T = Termination resistance should be equal to output impedance Z_o of the pulse generator.

b. Test circuit for 3-state outputs

Fig 6. Load circuitry for switching times

Table 8. Test data

Input				Load		V_{EXT}		
V_I	f_i	t_W	t_r, t_f	C_L	R_L	t_{PHZ}, t_{PZH}	t_{PLZ}, t_{PZL}	t_{PLH}, t_{PHL}
3.0 V	1 MHz	500 ns	2.5 ns	50 pF	500 Ω	open	7.0 V	open

13. Package outline

TSSOP48: plastic thin shrink small outline package; 48 leads; body width 6.1 mm

SOT362-1

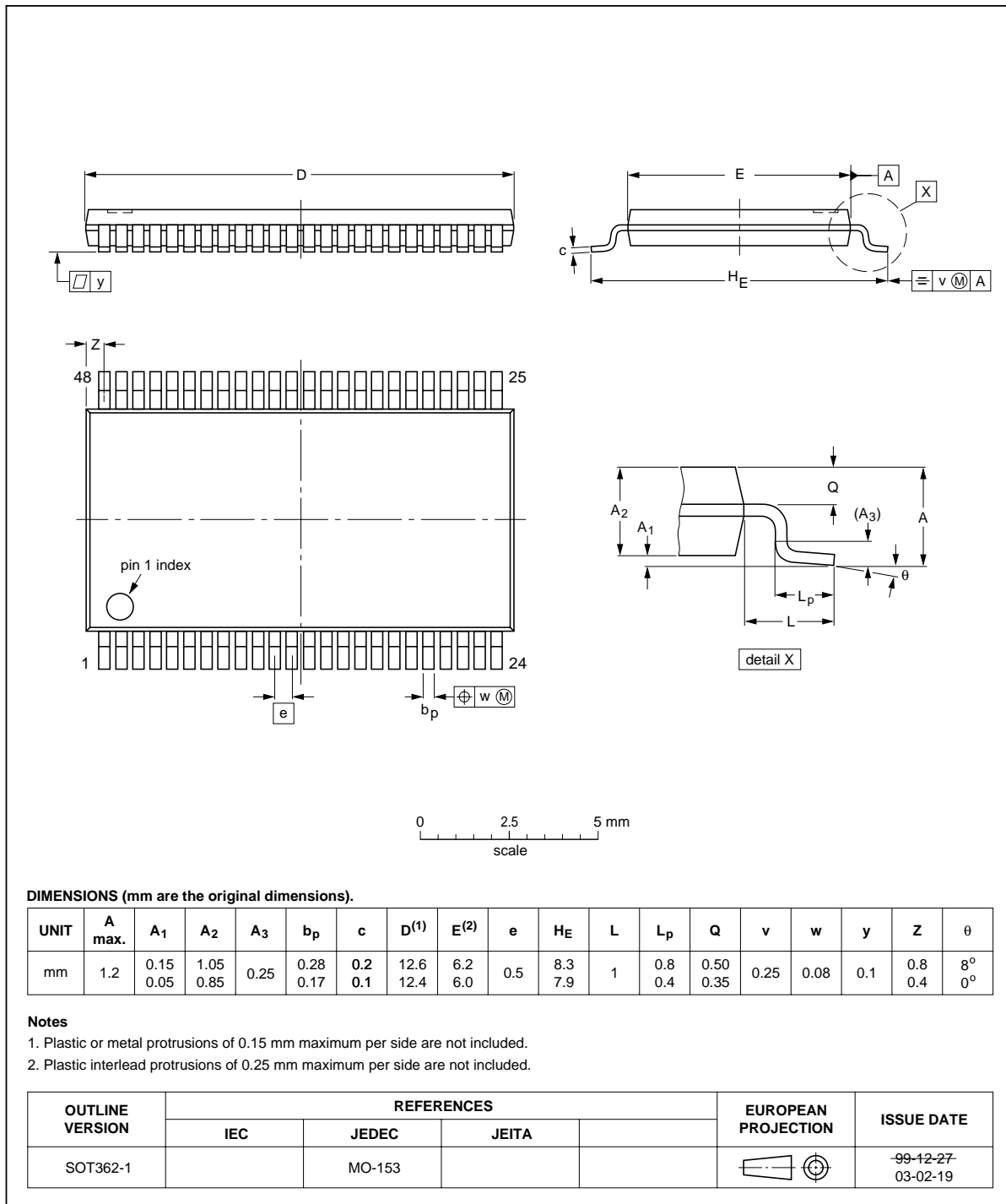

Fig 7. Package outline SOT362-1 (TSSOP48)

SSOP48: plastic shrink small outline package; 48 leads; body width 7.5 mm

SOT370-1

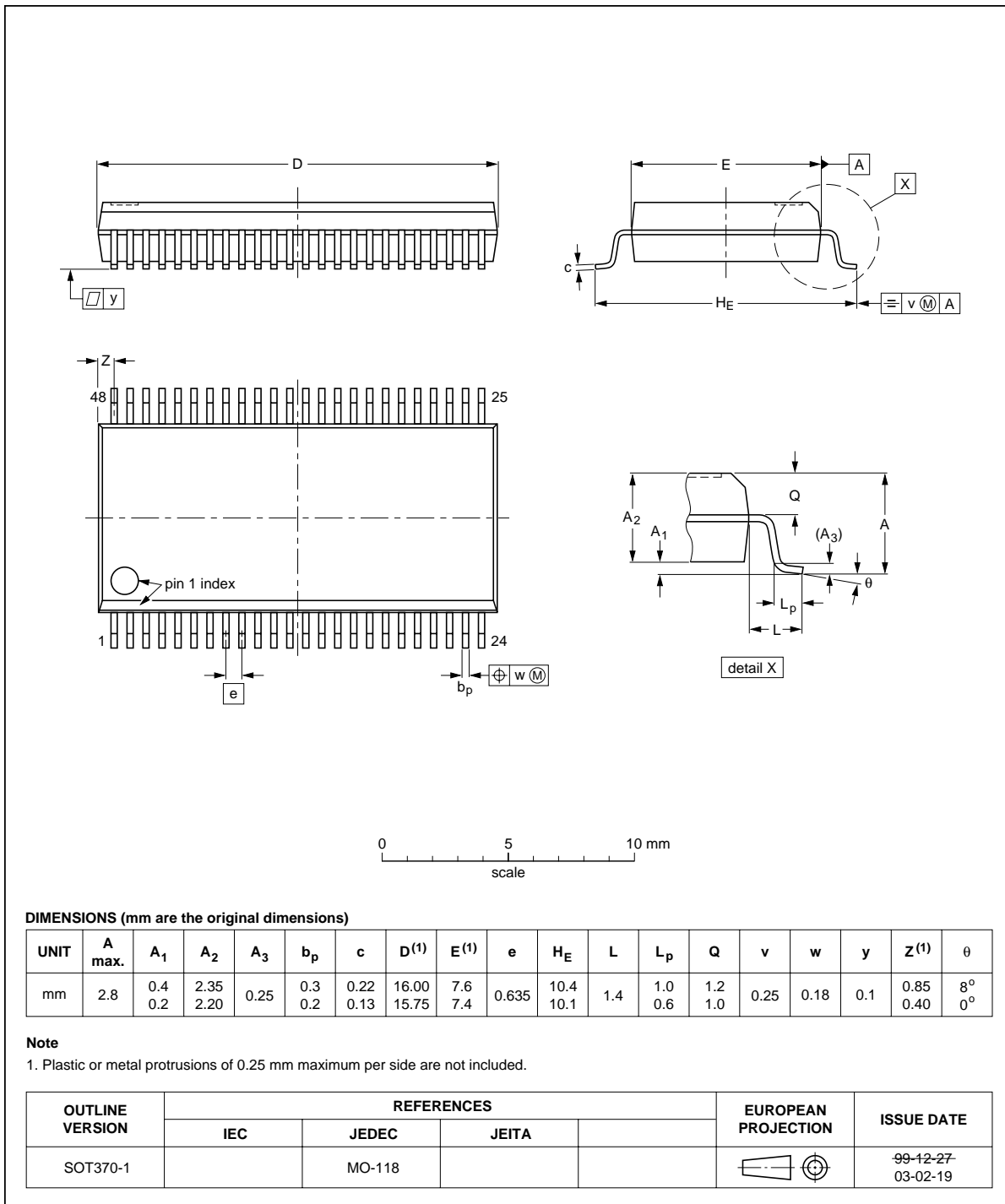

Fig 8. Package outline SOT370-1 (SSOP48)

14. Revision history

Table 9. Revision history

Document ID	Release date	Data sheet status	Change notice	Supersedes
74ABT16244A_6	20090323	Product data sheet	-	74ABT16244A_5
Modifications:	<ul style="list-style-type: none">• The format of this data sheet has been redesigned to comply with the new identity guidelines of NXP Semiconductors.• Legal texts have been adapted to the new company name where appropriate.			
74ABT16244A_5	20060210	Product data sheet	-	74ABT_H16244A_4
74ABT_H16244A_4	19981007	Product specification	-	74ABT_H16244A_3
74ABT_H16244A_3	19980225	Product specification	-	74ABT_H16244A_2

15. Legal information

15.1 Data sheet status

Document status ^{[1][2]}	Product status ^[3]	Definition
Objective [short] data sheet	Development	This document contains data from the objective specification for product development.
Preliminary [short] data sheet	Qualification	This document contains data from the preliminary specification.
Product [short] data sheet	Production	This document contains the product specification.

[1] Please consult the most recently issued document before initiating or completing a design.

[2] The term 'short data sheet' is explained in section "Definitions".

[3] The product status of device(s) described in this document may have changed since this document was published and may differ in case of multiple devices. The latest product status information is available on the Internet at URL <http://www.nxp.com>.

15.2 Definitions

Draft — The document is a draft version only. The content is still under internal review and subject to formal approval, which may result in modifications or additions. NXP Semiconductors does not give any representations or warranties as to the accuracy or completeness of information included herein and shall have no liability for the consequences of use of such information.

Short data sheet — A short data sheet is an extract from a full data sheet with the same product type number(s) and title. A short data sheet is intended for quick reference only and should not be relied upon to contain detailed and full information. For detailed and full information see the relevant full data sheet, which is available on request via the local NXP Semiconductors sales office. In case of any inconsistency or conflict with the short data sheet, the full data sheet shall prevail.

15.3 Disclaimers

General — Information in this document is believed to be accurate and reliable. However, NXP Semiconductors does not give any representations or warranties, expressed or implied, as to the accuracy or completeness of such information and shall have no liability for the consequences of use of such information.

Right to make changes — NXP Semiconductors reserves the right to make changes to information published in this document, including without limitation specifications and product descriptions, at any time and without notice. This document supersedes and replaces all information supplied prior to the publication hereof.

Suitability for use — NXP Semiconductors products are not designed, authorized or warranted to be suitable for use in medical, military, aircraft, space or life support equipment, nor in applications where failure or malfunction of an NXP Semiconductors product can reasonably be expected to result in personal injury, death or severe property or environmental

damage. NXP Semiconductors accepts no liability for inclusion and/or use of NXP Semiconductors products in such equipment or applications and therefore such inclusion and/or use is at the customer's own risk.

Applications — Applications that are described herein for any of these products are for illustrative purposes only. NXP Semiconductors makes no representation or warranty that such applications will be suitable for the specified use without further testing or modification.

Limiting values — Stress above one or more limiting values (as defined in the Absolute Maximum Ratings System of IEC 60134) may cause permanent damage to the device. Limiting values are stress ratings only and operation of the device at these or any other conditions above those given in the Characteristics sections of this document is not implied. Exposure to limiting values for extended periods may affect device reliability.

Terms and conditions of sale — NXP Semiconductors products are sold subject to the general terms and conditions of commercial sale, as published at <http://www.nxp.com/profile/terms>, including those pertaining to warranty, intellectual property rights infringement and limitation of liability, unless explicitly otherwise agreed to in writing by NXP Semiconductors. In case of any inconsistency or conflict between information in this document and such terms and conditions, the latter will prevail.

No offer to sell or license — Nothing in this document may be interpreted or construed as an offer to sell products that is open for acceptance or the grant, conveyance or implication of any license under any copyrights, patents or other industrial or intellectual property rights.

Export control — This document as well as the item(s) described herein may be subject to export control regulations. Export might require a prior authorization from national authorities.

15.4 Trademarks

Notice: All referenced brands, product names, service names and trademarks are the property of their respective owners.

16. Contact information

For more information, please visit: <http://www.nxp.com>

For sales office addresses, please send an email to: salesaddresses@nxp.com

17. Contents

1	General description	1
2	Features	1
3	Ordering information	1
4	Functional diagram	2
5	Pinning information	3
5.1	Pinning	3
5.2	Pin description	3
6	Functional description	4
7	Limiting values	4
8	Recommended operating conditions	5
9	Static characteristics	5
10	Dynamic characteristics	6
11	Waveforms	7
12	Test information	8
13	Package outline	9
14	Revision history	11
15	Legal information	12
15.1	Data sheet status	12
15.2	Definitions	12
15.3	Disclaimers	12
15.4	Trademarks	12
16	Contact information	12
17	Contents	13

founded by



Please be aware that important notices concerning this document and the product(s) described herein, have been included in section 'Legal information'.

© NXP B.V. 2009.

All rights reserved.

For more information, please visit: <http://www.nxp.com>For sales office addresses, please send an email to: salesaddresses@nxp.com

Date of release: 23 March 2009

Document identifier: 74ABT16244A_6