

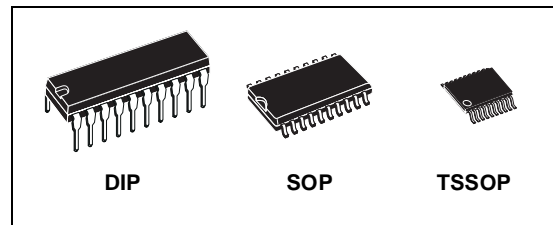

74AC299

8 BIT PIPO SHIFT REGISTER WITH ASYNCHRONOUS CLEAR

- HIGH SPEED:
 - $f_{MAX} = 240\text{MHz}$ (TYP.) at $V_{CC} = 5\text{V}$
- LOW POWER DISSIPATION:
 - $I_{CC} = 8\mu\text{A}$ (MAX.) at $T_A=25^\circ\text{C}$
- HIGH NOISE IMMUNITY:
 - $V_{NIH} = V_{NIL} = 28\% V_{CC}$ (MIN.)
- 50Ω TRANSMISSION LINE DRIVING CAPABILITY
- SYMMETRICAL OUTPUT IMPEDANCE:
 - $|I_{OH}| = I_{OL} = 24\text{mA}$ (MIN)
- BALANCED PROPAGATION DELAYS:
 - $t_{PLH} \approx t_{PHL}$
- OPERATING VOLTAGE RANGE:
 - V_{CC} (OPR) = 2V to 6V
- PIN AND FUNCTION COMPATIBLE WITH 74 SERIES 299
- IMPROVED LATCH-UP IMMUNITY



ORDER CODES

PACKAGE	TUBE	T & R
DIP	74AC299B	
SOP	74AC299M	74AC299MTR
TSSOP		74AC299TTR

DESCRIPTION

The 74AC299 is an advanced high-speed CMOS 8-BIT PIPO SHIFT REGISTER (3-STATE) fabricated with sub-micron silicon gate and double-layer metal wiring C²MOS technology. These devices have four modes (HOLD, SHIFT LEFT, SHIFT RIGHT and LOAD DATA). Each mode is chosen by two function select inputs (S0,

S1) as shown in the Truth Table. When one or both enable inputs, (G1, G2) are high, the eight input/output terminals are in the high-impedance state; however sequential operation or clearing of the register is not affected. Clear function is asynchronous to clock.

All inputs and outputs are equipped with protection circuits against static discharge, giving them 2KV ESD immunity and transient excess voltage.

PIN CONNECTION AND IEC LOGIC SYMBOLS

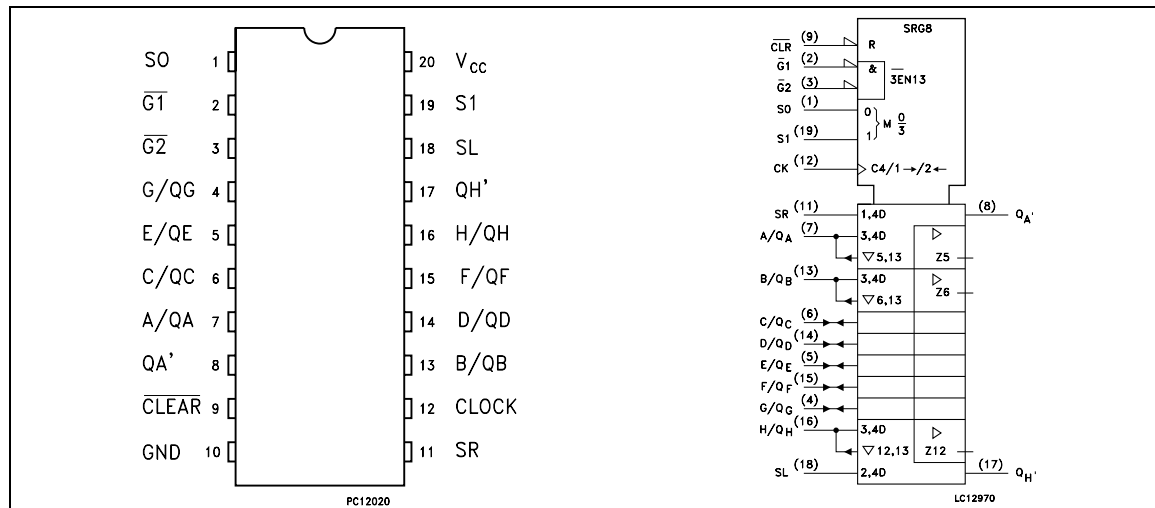

INPUT AND OUTPUT EQUIVALENT CIRCUIT

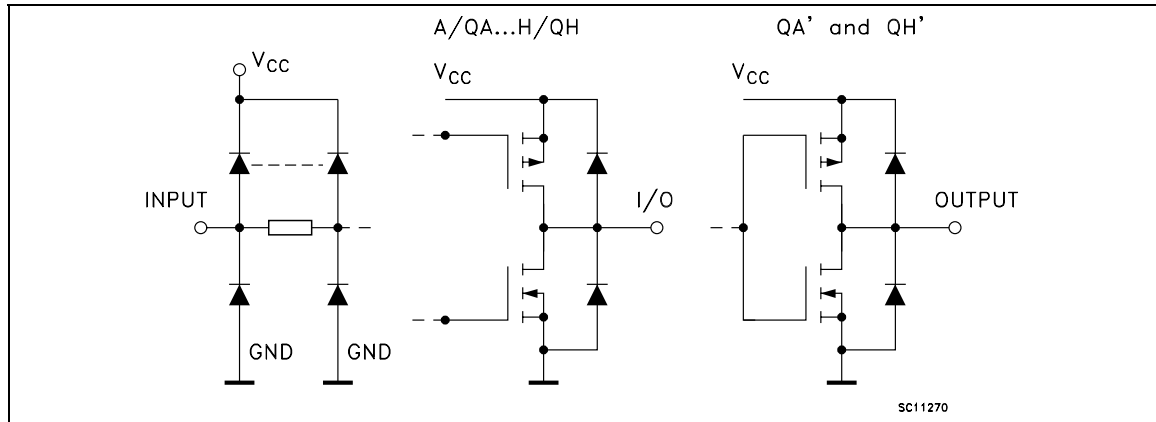

PIN DESCRIPTION

PIN No	SYMBOL	NAME AND FUNCTION
1, 19	S0, S1	Mode Select Inputs
2, 3	G1, G2	3-State Output Enable Inputs (Active LOW)
7, 13, 6, 14, 5, 15, 4, 16	A/QA to H/QH	Parallel Data Inputs or 3-State Parallel Outputs (Bus Driver)
8, 17	QA' to QH'	Serial Outputs (Standard Output)
9	CLEAR	Asynchronous Master Reset Input (Active LOW)
11	SR	Serial Data Shift Right Input
12	CLOCK	Clock Input (LOW to HIGH, Edge-triggered)
18	SL	Serial Data Shift Left Input
10	GND	Ground (0V)
20	V _{CC}	Positive Supply Voltage

TRUTH TABLE

MODE	INPUTS						INPUTS/OUTPUTS				OUTPUTS	
	CLEAR	FUNCTION SELECTED		OUTPUT CONTROL		CLOCK	SERIAL		A/QA	H/QH	QA'	QH'
		S1	S0	G1*	G2*		SL	SR				
Z	L	H	H	X	X	X	X	X	Z	Z	L	L
CLEAR	L	L	X	L	L	X	X	X	L	L	L	L
	L	X	L	L	L	X	X	X	L	L	L	L
HOLD	H	L	L	L	L	X	X	X	QA0	QH0	QA0	QH0
SHIFT RIGHT	H	L	H	L	L	⌋	X	H	H	QGn	H	QGn
	H	L	H	L	L	⌋	X	L	L	QGn	L	QGn
SHIFT LEFT	H	H	L	L	L	⌋	H	X	QBn	H	QBn	H
	H	H	L	L	L	⌋	L	X	QBn	L	QBn	L
LOAD	H	H	H	X	X	⌋	X	X	a	h	a	h

* When one or both controls are high, the eight input/output terminals are the high impedance state: however sequential operation or cleaning of the register is not affected.

Z : High Impedance

Qn0 : The level of An before the indicated steady state input conditions were established.

Qnn : The level of Qn before the most recent active transition indicated by OR

a, h : The level of the steadystate inputs A, H, respectively.

X : Don't Care



LOGIC DIAGRAM

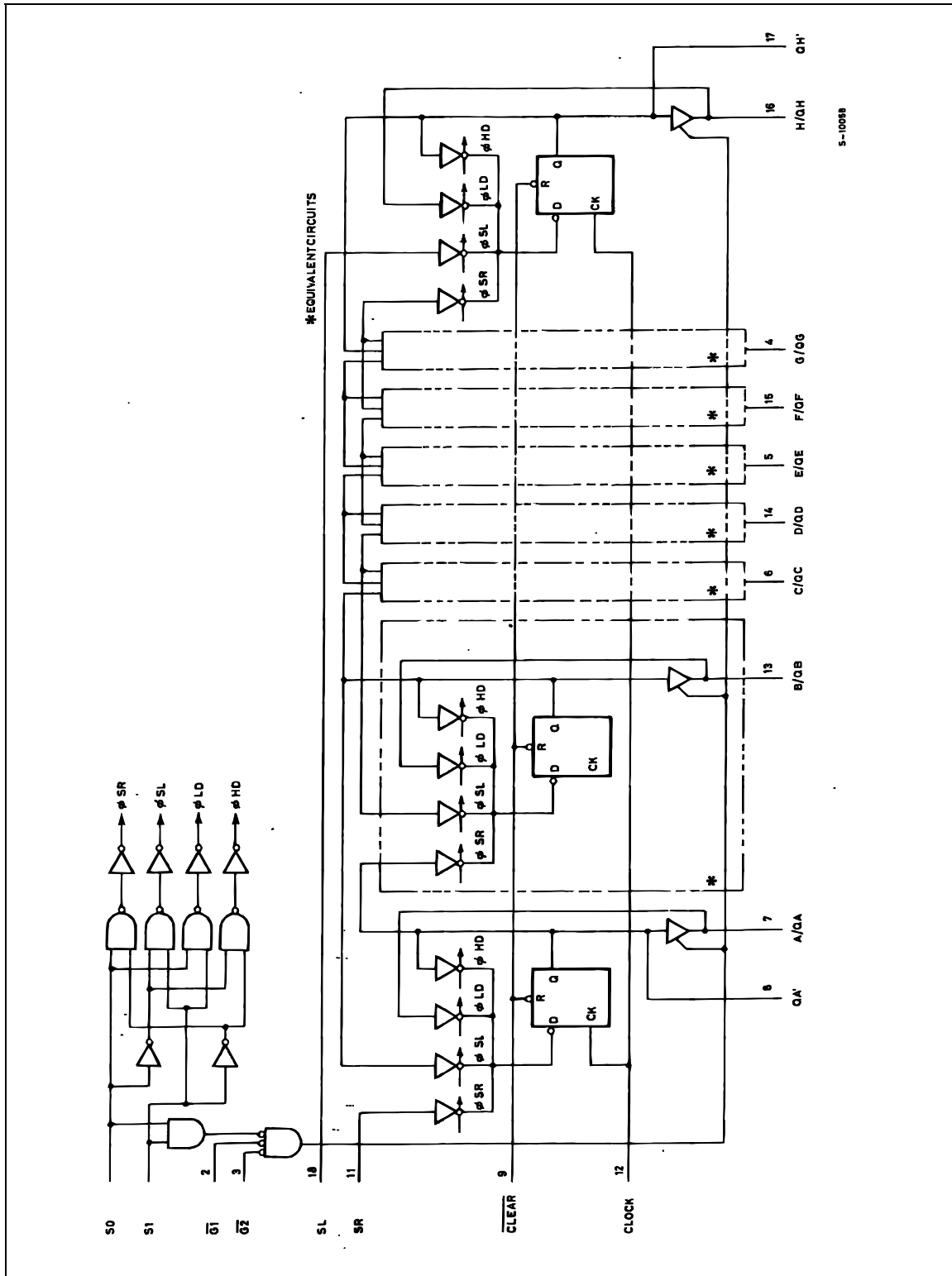

TIMING CHART

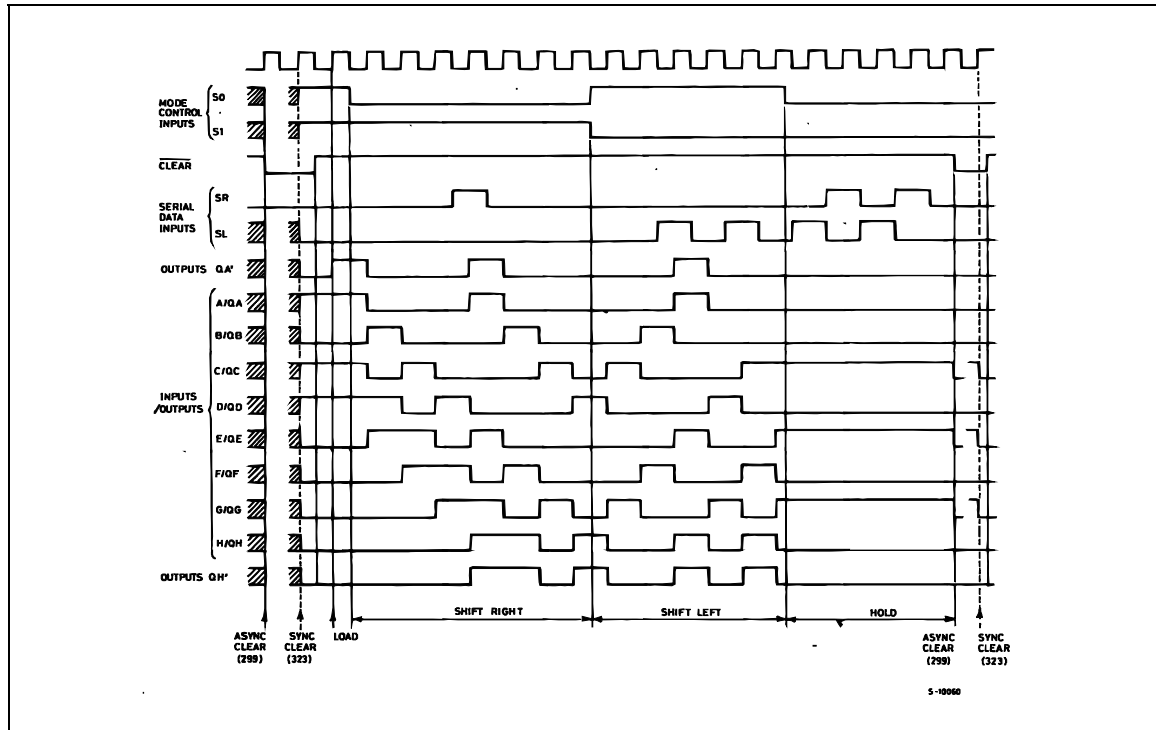

ABSOLUTE MAXIMUM RATINGS

Symbol	Parameter	Value	Unit
V_{CC}	Supply Voltage	-0.5 to +7	V
V_I	DC Input Voltage	-0.5 to $V_{CC} + 0.5$	V
V_O	DC Output Voltage	-0.5 to $V_{CC} + 0.5$	V
I_{IK}	DC Input Diode Current	± 20	mA
I_{OK}	DC Output Diode Current	± 20	mA
I_O	DC Output Current	± 50	mA
I_{CC} or I_{GND}	DC V_{CC} or Ground Current	± 400	mA
T_{stg}	Storage Temperature	-65 to +150	$^{\circ}C$
T_L	Lead Temperature (10 sec)	300	$^{\circ}C$

Absolute Maximum Ratings are those values beyond which damage to the device may occur. Functional operation under these conditions is not implied.

RECOMMENDED OPERATING CONDITIONS

Symbol	Parameter	Value	Unit
V_{CC}	Supply Voltage	2 to 6	V
V_I	Input Voltage	0 to V_{CC}	V
V_O	Output Voltage	0 to V_{CC}	V
T_{op}	Operating Temperature	-55 to 125	$^{\circ}C$
dt/dv	Input Rise and Fall Time $V_{CC} = 3.0, 4.5$ or $5.5V$ (note 1)	8	ns/V

1) V_{IN} from 30% to 70% of V_{CC}

DC SPECIFICATIONS

Symbol	Parameter	Test Condition		Value						Unit	
		V _{CC} (V)		T _A = 25°C			-40 to 85°C		-55 to 125°C		
				Min.	Typ.	Max.	Min.	Max.	Min.		Max.
V _{IH}	High Level Input Voltage	3.0	V _O = 0.1 V or V _{CC} -0.1V	2.1	1.5		2.1		2.1		V
		4.5		3.15	2.25		3.15		3.15		
		5.5		3.85	2.75		3.85		3.85		
V _{IL}	Low Level Input Voltage	3.0	V _O = 0.1 V or V _{CC} -0.1V		1.5	0.9		0.9		0.9	V
		4.5			2.25	1.35		1.35		1.35	
		5.5			2.75	1.65		1.65		1.65	
V _{OH}	High Level Output Voltage	3.0	I _O =-50 μA	2.9	2.99		2.9		2.9		V
		4.5	I _O =-50 μA	4.4	4.49		4.4		4.4		
		5.5	I _O =-50 μA	5.4	5.49		5.4		5.4		
		3.0	I _O =-12 mA	2.56			2.46		2.4		
		4.5	I _O =-24 mA	3.86			3.76		3.7		
		5.5	I _O =-24 mA	4.86			4.76		4.7		
V _{OL}	Low Level Output Voltage	3.0	I _O =50 μA		0.002	0.1		0.1		0.1	V
		4.5	I _O =50 μA		0.001	0.1		0.1		0.1	
		5.5	I _O =50 μA		0.001	0.1		0.1		0.1	
		3.0	I _O =12 mA			0.36		0.44		0.5	
		4.5	I _O =24 mA			0.36		0.44		0.5	
		5.5	I _O =24 mA			0.36		0.44		0.5	
I _I	Input Leakage Current	5.5	V _I = V _{CC} or GND			± 0.1		± 1		± 1	μA
I _{oz}	High Impedance Output Leakage Current	5.5	V _I = V _{IH} or V _{IL} V _O = V _{CC} or GND			± 0.5		± 5		± 10	μA
I _{CC}	Quiescent Supply Current	5.5	V _I = V _{CC} or GND			8		80		160	μA
I _{OLD}	Dynamic Output Current (note 1, 2)	5.5	V _{OLD} = 1.65 V max					75		50	mA
I _{OHD}			V _{OHD} = 3.85 V min					-75		-50	mA

1) Maximum test duration 2ms, one output loaded at time

2) Incident wave switching is guaranteed on transmission lines with impedances as low as 50Ω

AC ELECTRICAL CHARACTERISTICS ($C_L = 50 \text{ pF}$, $R_L = 500 \Omega$, Input $t_r = t_f = 3 \text{ ns}$)

Symbol	Parameter	Test Condition		Value						Unit	
				$T_A = 25^\circ\text{C}$			$-40 \text{ to } 85^\circ\text{C}$		$-55 \text{ to } 125^\circ\text{C}$		
				Min.	Typ.	Max.	Min.	Max.	Min.		Max.
$t_{PLH} \ t_{PHL}$	Propagation Delay Time CLOCK to Q'_A , Q'_H	3.3 ^(*)			10.6	18.4	1.0	21.0	1.0	21.0	ns
		5.0 ^(**)			6.8	10.5	1.0	12.0	1.0	12.0	
$t_{PLH} \ t_{PHL}$	Propagation Delay Time CLOCK to Q_A , Q_H	3.3 ^(*)			10.9	19.3	1.0	22.0	1.0	22.0	ns
		5.0 ^(**)			7.3	10.5	1.0	12.0	1.0	12.0	
$t_{PLH} \ t_{PHL}$	Propagation Delay Time CLEAR to Q'_A , Q'_H	3.3 ^(*)			8.1	14.0	1.0	16.0	1.0	16.0	ns
		5.0 ^(**)			6.1	9.2	1.0	10.5	1.0	10.5	
$t_{PLH} \ t_{PHL}$	Propagation Delay Time CLEAR to Q_A , Q_H	3.3 ^(*)			9.8	16.7	1.0	19.0	1.0	19.0	ns
		5.0 ^(**)			6.7	10.9	1.0	12.4	1.0	12.4	
$t_{PZL} \ t_{PZH}$	Output Enable Time	3.3 ^(*)			9.9	17.5	1.0	20.0	1.0	20.0	ns
		5.0 ^(**)			6.6	9.6	1.0	11.4	1.0	11.4	
$t_{PLZ} \ t_{PHZ}$	Output Disable Time	3.3 ^(*)			8.1	14.0	1.0	16.0	1.0	16.0	ns
		5.0 ^(**)			6.4	9.6	1.0	11.0	1.0	11.0	
t_W	CLEAR Pulse Width LOW	3.3 ^(*)				7.0		7.0		7.0	ns
		5.0 ^(**)				5.0		5.0		5.0	
t_W	CLOCK Pulse Width LOW	3.3 ^(*)				8.0		8.0		8.0	ns
		5.0 ^(**)				5.0		5.0		5.0	
t_s	Setup Time HIGH or LOW (S0 or S1 to CLOCK)	3.3 ^(*)				11.9		13.6		13.6	ns
		5.0 ^(**)				7.0		7.0		7.0	
t_h	Hold Time HIGH or LOW (S0 or S1 to CLOCK)	3.3 ^(*)				0.0		0.0		0.0	ns
		5.0 ^(**)				0.0		0.0		0.0	
t_s	Setup Time HIGH or LOW (SR or SL to CLOCK)	3.3 ^(*)				6.0		6.0		6.0	ns
		5.0 ^(**)				4.0		4.0		4.0	
t_h	Hold Time HIGH or LOW (SR or SL to CLOCK)	3.3 ^(*)				1.0		1.0		1.0	ns
		5.0 ^(**)				1.0		1.0		1.0	
t_{REM}	Recovery Time CLEAR to CLOCK	3.3 ^(*)				5.0		5.0		5.0	ns
		5.0 ^(**)				3.0		3.0		3.0	
f_{MAX}	Maximum Clock Frequency	3.3 ^(*)			45	210		45		45	MHz
		5.0 ^(**)			80	240		80		80	

(*) Voltage range is $3.3\text{V} \pm 0.3\text{V}$ (**) Voltage range is $5.0\text{V} \pm 0.5\text{V}$

CAPACITIVE CHARACTERISTICS

Symbol	Parameter	Test Condition		Value						Unit	
		V _{CC} (V)		T _A = 25°C			-40 to 85°C		-55 to 125°C		
				Min.	Typ.	Max.	Min.	Max.	Min.		Max.
C _{IN}	Input Capacitance	5.0			5	10		10			pF
C _{i/O}	Bus Input Capacitance	5.0			13						pF
C _{PD}	Power Dissipation Capacitance (note 1)	5.0	f _{IN} = 10MHz		120						pF

1) C_{PD} is defined as the value of the IC's internal equivalent capacitance which is calculated from the operating current consumption without load. (Refer to Test Circuit). Average operating current can be obtained by the following equation. $I_{CC(oper)} = C_{PD} \times V_{CC} \times f_{IN} + I_{CC}/n$ (per circuit)

TEST CIRCUIT

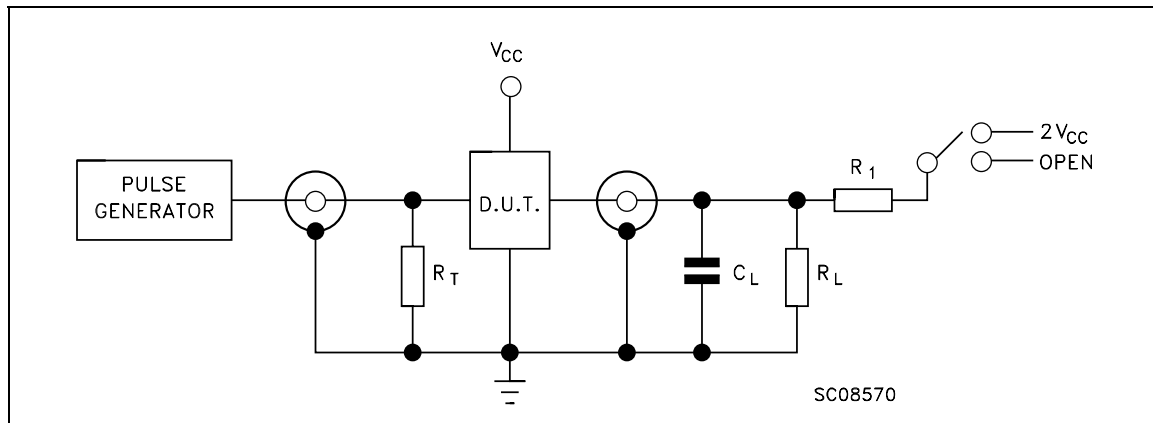

TEST	SWITCH
t _{PLH} , t _{PHL}	Open
t _{PZL} , t _{PLZ}	2V _{CC}
t _{PZH} , t _{PHZ}	Open

C_L = 50pF or equivalent (includes jig and probe capacitance)
R_L = R₁ = 500Ω or equivalent
R_T = Z_{OUT} of pulse generator (typically 50Ω)

WAVEFORM 1: PROPAGATION DELAYS (f=1MHz; 50% duty cycle)

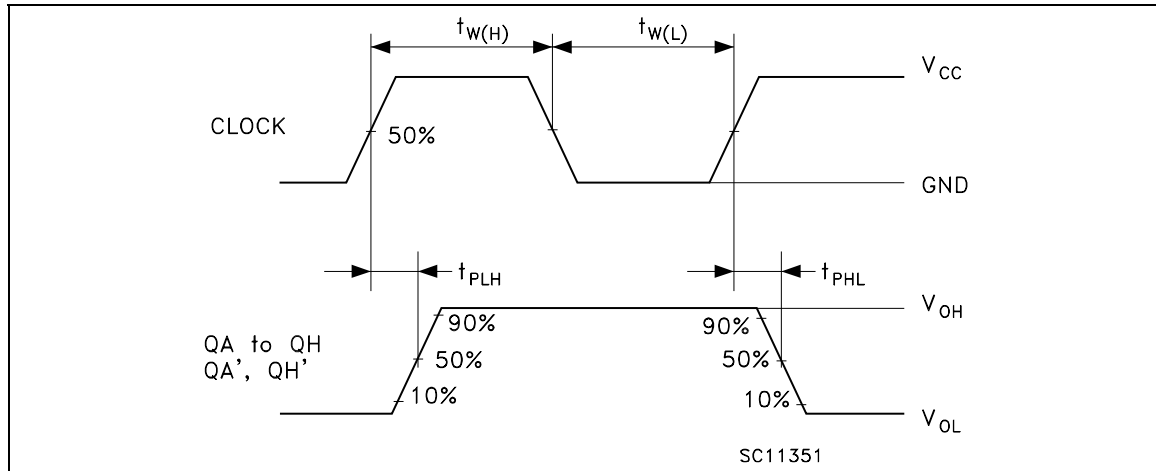

WAVEFORM 2: PROPAGATION DELAYS (f=1MHz; 50% duty cycle)

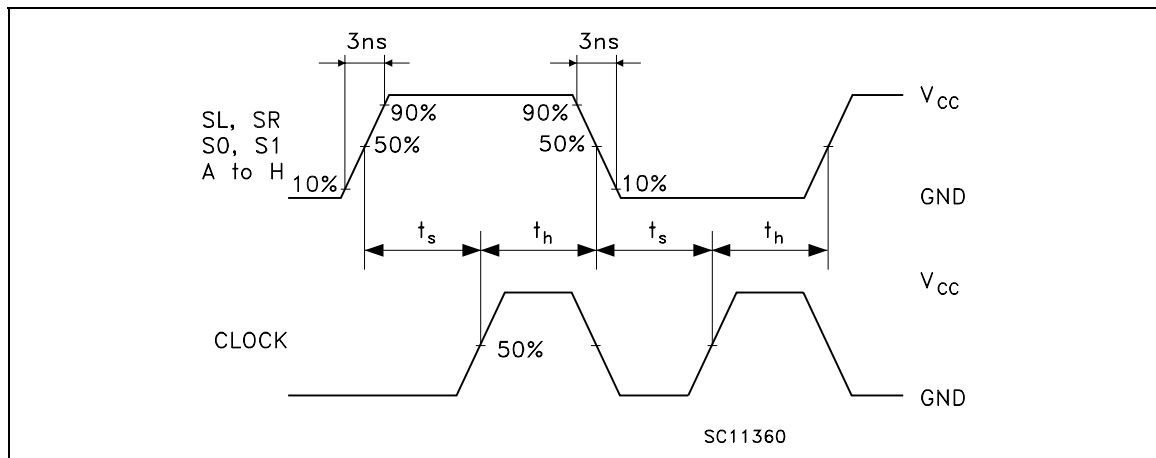

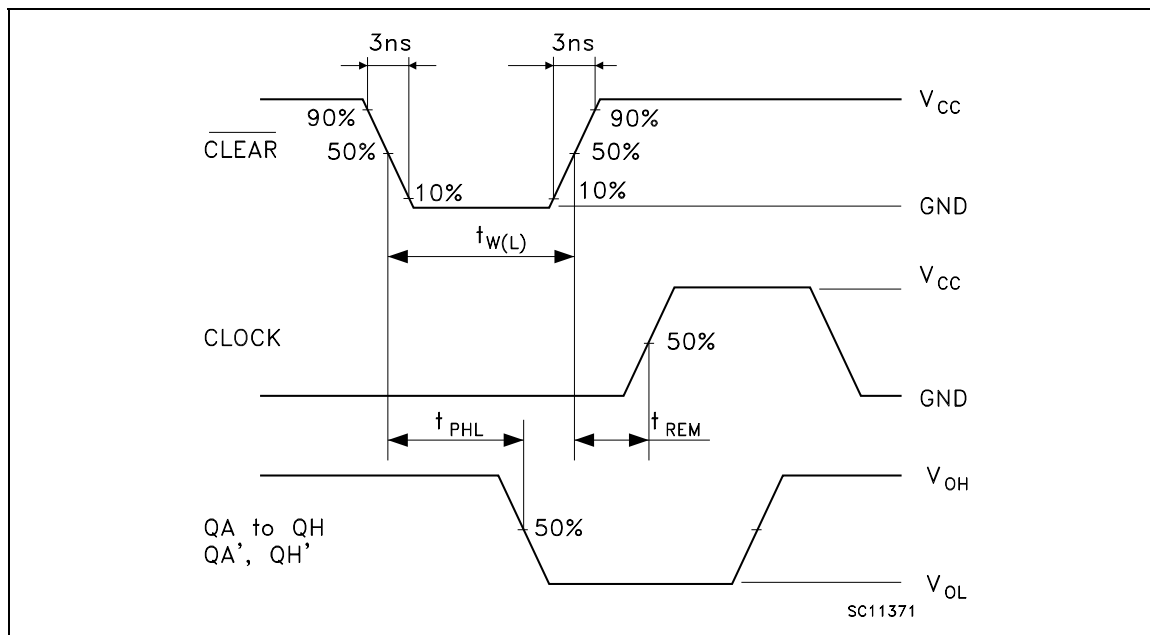
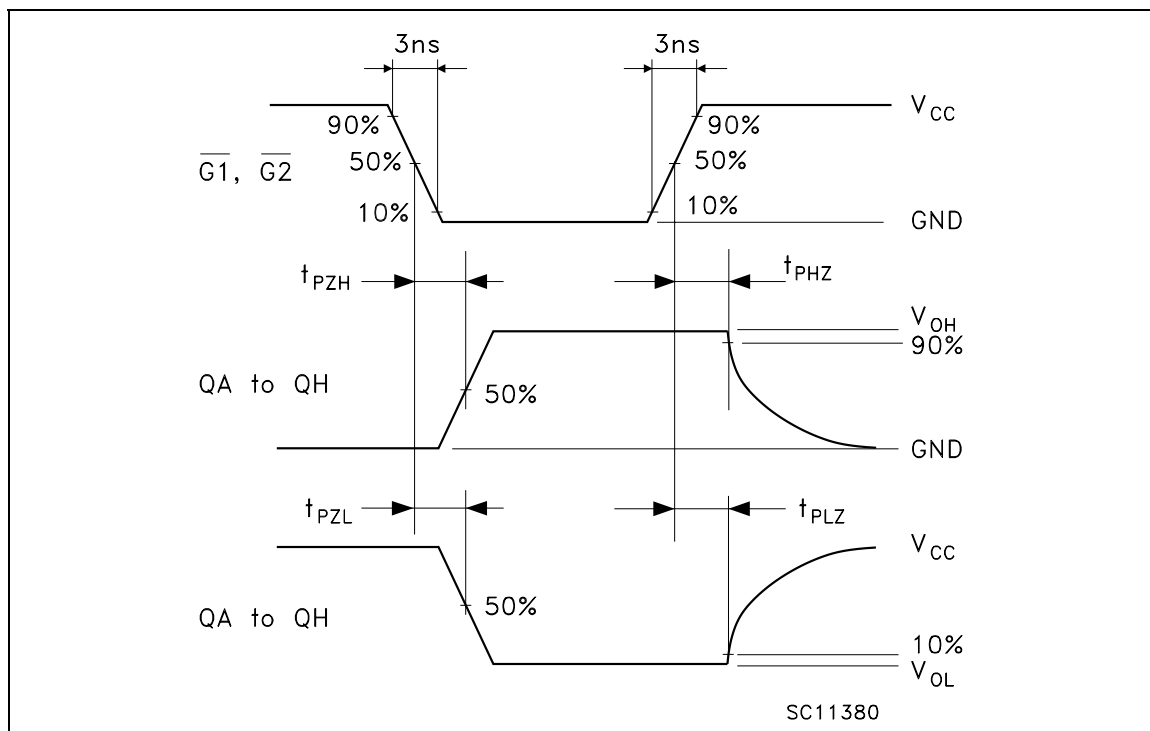
WAVEFORM 3: PROPAGATION DELAYS (f=1MHz; 50% duty cycle)**WAVEFORM 4: PROPAGATION DELAYS** (f=1MHz; 50% duty cycle)

Plastic DIP-20 (0.25) MECHANICAL DATA

DIM.	mm			inch		
	MIN.	TYP.	MAX.	MIN.	TYP.	MAX.
a1	0.254			0.010		
B	1.39		1.65	0.055		0.065
b		0.45			0.018	
b1		0.25			0.010	
D			25.4			1.000
E		8.5			0.335	
e		2.54			0.100	
e3		22.86			0.900	
F			7.1			0.280
l			3.93			0.155
L		3.3			0.130	
Z			1.34			0.053

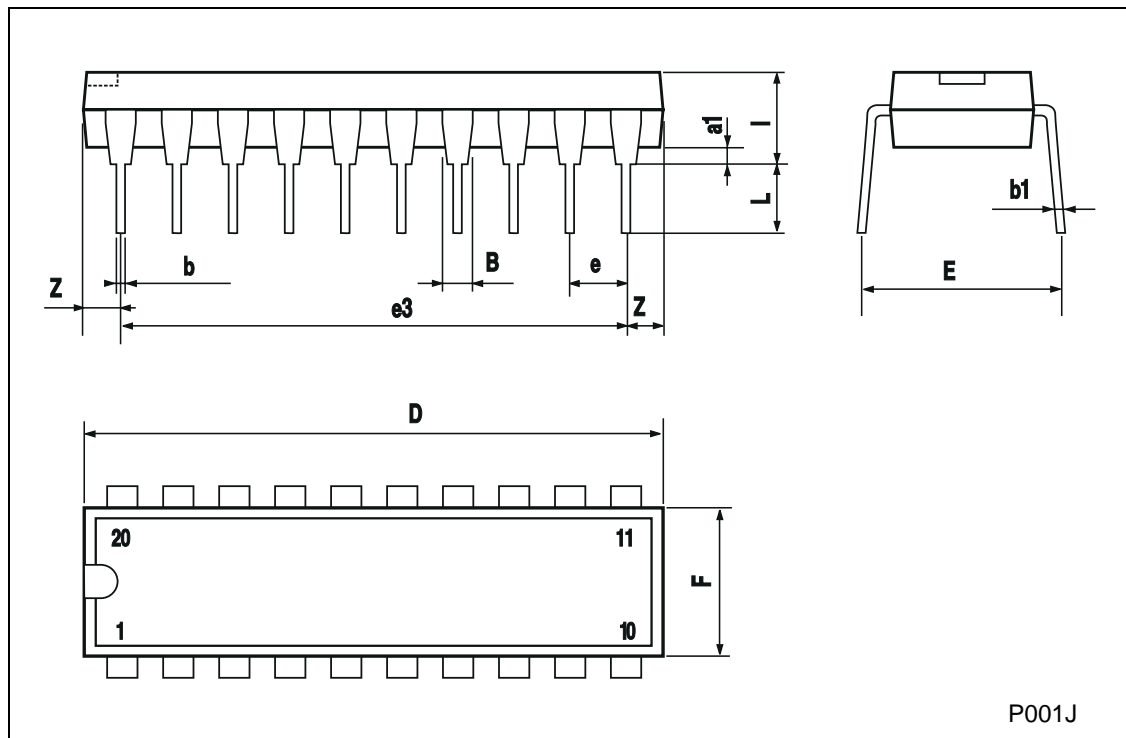

SO-20 MECHANICAL DATA

DIM.	mm			inch		
	MIN.	TYP.	MAX.	MIN.	TYP.	MAX.
A			2.65			0.104
a1	0.10		0.20	0.004		0.007
a2			2.45			0.096
b	0.35		0.49	0.013		0.019
b1	0.23		0.32	0.009		0.012
C		0.50			0.020	
c1	45 (typ.)					
D	12.60		13.00	0.496		0.512
E	10.00		10.65	0.393		0.419
e		1.27			0.050	
e3		11.43			0.450	
F	7.40		7.60	0.291		0.299
L	0.50		1.27	0.19		0.050
M			0.75			0.029
S	8 (max.)					

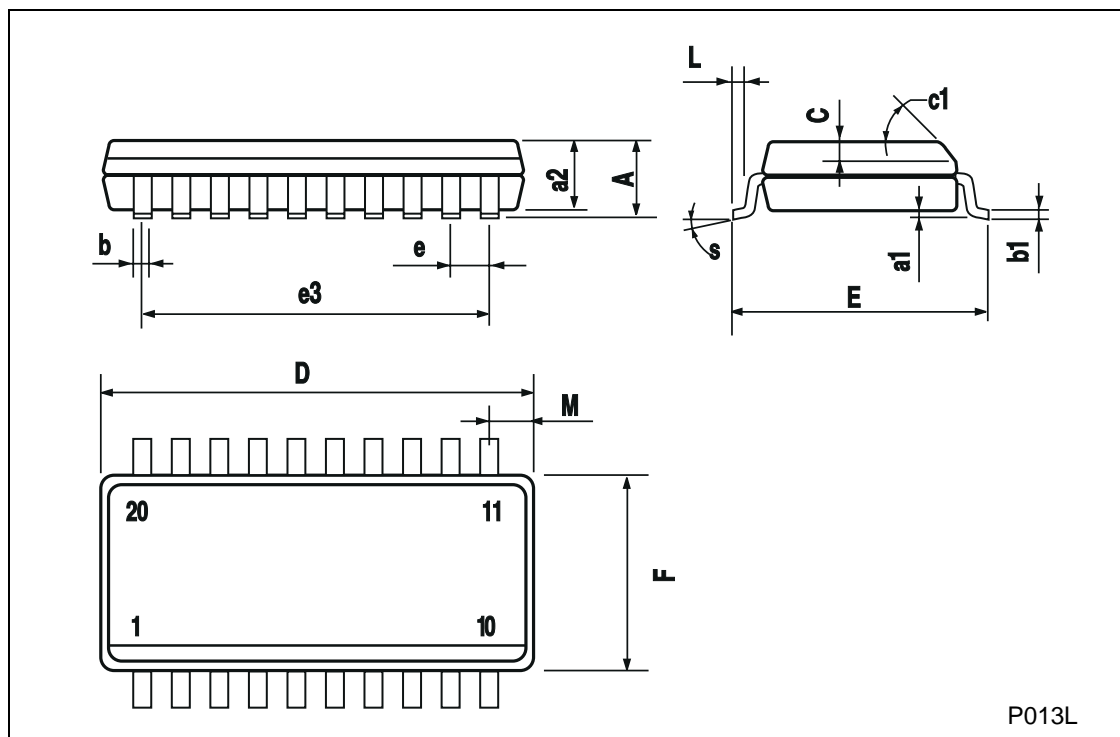

P013L

TSSOP20 MECHANICAL DATA

DIM.	mm			inch		
	MIN.	TYP.	MAX.	MIN.	TYP.	MAX.
A			1.1			0.433
A1	0.05	0.10	0.15	0.002	0.004	0.006
A2	0.85	0.9	0.95	0.335	0.354	0.374
b	0.19		0.30	0.0075		0.0118
c	0.09		0.2	0.0035		0.0079
D	6.4	6.5	6.6	0.252	0.256	0.260
E	6.25	6.4	6.5	0.246	0.252	0.256
E1	4.3	4.4	4.48	0.169	0.173	0.176
e		0.65 BSC			0.0256 BSC	
K	0°	4°	8°	0°	4°	8°
L	0.50	0.60	0.70	0.020	0.024	0.028

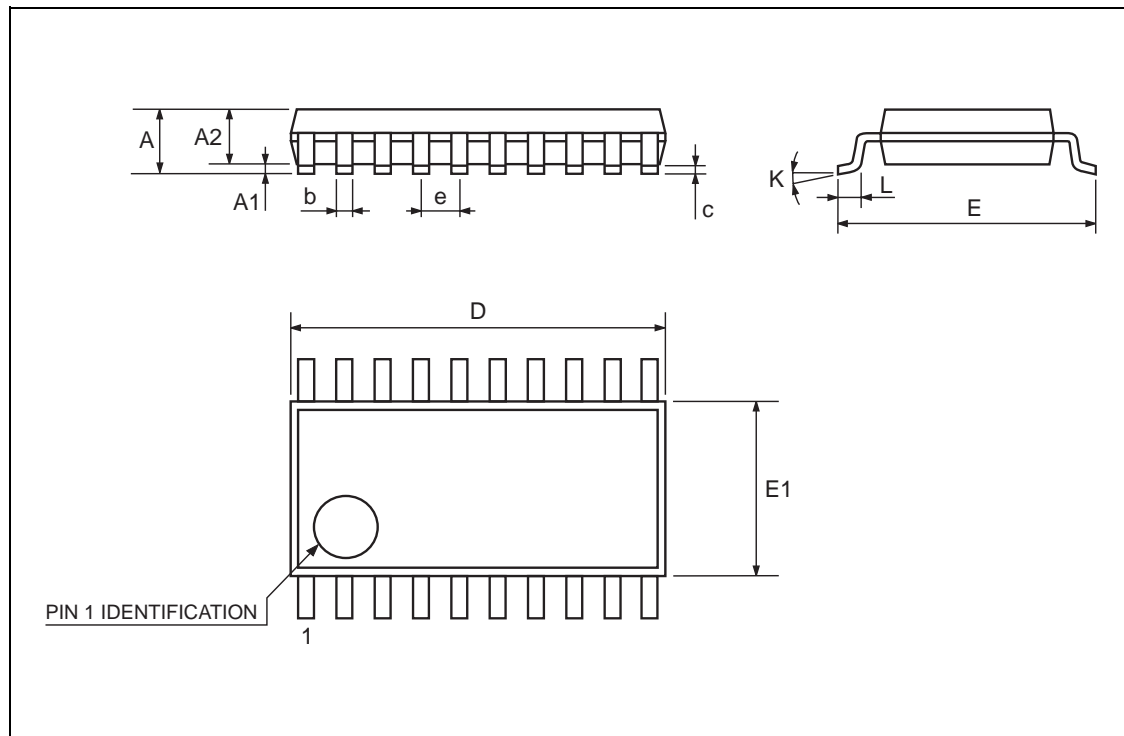

Information furnished is believed to be accurate and reliable. However, STMicroelectronics assumes no responsibility for the consequences of use of such information nor for any infringement of patents or other rights of third parties which may result from its use. No license is granted by implication or otherwise under any patent or patent rights of STMicroelectronics. Specifications mentioned in this publication are subject to change without notice. This publication supersedes and replaces all information previously supplied. STMicroelectronics products are not authorized for use as critical components in life support devices or systems without express written approval of STMicroelectronics.

© The ST logo is a registered trademark of STMicroelectronics

© 2001 STMicroelectronics - Printed in Italy - All Rights Reserved
STMicroelectronics GROUP OF COMPANIES

Australia - Brazil - China - Finland - France - Germany - Hong Kong - India - Italy - Japan - Malaysia - Malta - Morocco
Singapore - Spain - Sweden - Switzerland - United Kingdom

© <http://www.st.com>

