

ML6424*/ML6425*

CCIR601 Video Lowpass Filter with Optional Sinx/x Correction

GENERAL DESCRIPTION

The ML6424 is a monolithic BiCMOS Video Lowpass Filter IC, incorporating a 5th order Elliptic (Cauer) lowpass filter, a third order allpass filter, and a 75Ω coax cable driver. The ML6425 additionally provides sinx/x amplitude correction. These active lowpass filters are available with a 2.75MHz (-2) or a 5.50MHz (-1) cutoff frequency.

The input signal can be either AC or DC coupled under the control of the MODE pin. In the DC coupled case, a control pin (RANGE) is provided to allow the inputs to swing down to ground. Internal self clamping is provided for AC coupled signals.

The ML6424 and ML6425 are powered by a single 5V supply, and can drive $1V_{PP}$ into 75Ω (0.5V to 1.5V), or $2V_{PP}$ into 150Ω (0.5 to 2.5V). The maximum output swing from 0.5V to 2.5V allows easy interface to the ML6400 family of A/D converters.

FEATURES

- External or internal input clamping with pulse output for synchronous clamping of multiple filters
- Frequency tunable with R_{EXT} : $\pm 10\%$
- $\pm 0.25\text{dB}$ ripple
- $>40\text{dB}$ attenuation at $f > 1.45 \times f_C$ (w/o sinx/x)
- $>35\text{dB}$ attenuation at $f > 1.45 \times f_C$ (with sinx/x)
- -12dB attenuation at $f = 1.23 \times f_C$
- Group delay distortion: $\pm 20\text{ns}$ up to $0.9 \times f_C$
- $<1\%$ peak overshoot and ringing on 2T test pulse
- 0.5% diff. gain and 0.5% diff. phase typical
- THD $<1\%$ at 3.58 or 4.43MHz
- Programmable input-output gain of 1x or 2x
- 5V $\pm 5\%$ operation

*Some packages Are Obsolete

BLOCK DIAGRAM

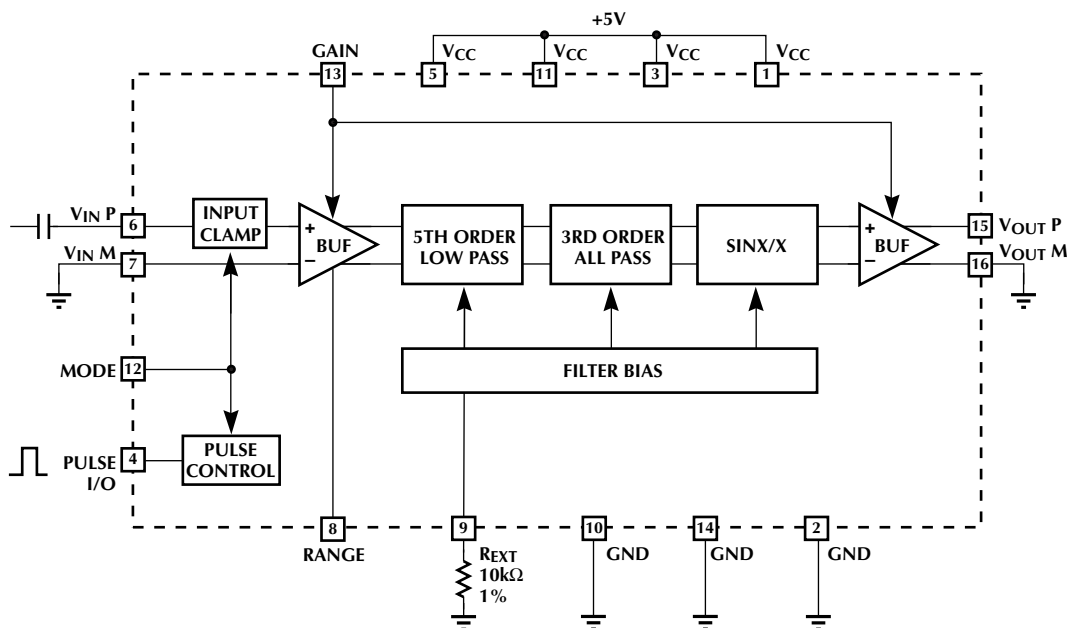

	ML6424-1	ML6424-2	ML6425-1	ML6425-2
Bandwidth	5.50MHz	2.75MHz	5.50MHz	2.75MHz
Sinx/x	No	No	Yes	Yes

ML6424/ML6425

PIN CONFIGURATION

Package: S16W
16-Pin SOIC

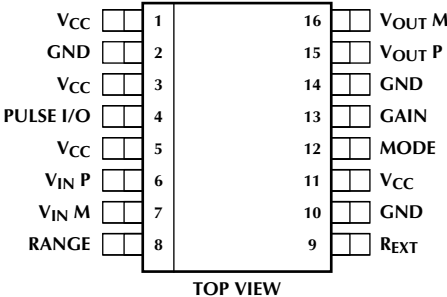

PIN DESCRIPTION

Pin #	Name	Description	Pin #	Name	Description
1,3,5,11	V _{CC}	Positive supply voltages (4.75V to 5.25V).	12	MODE	Input coupling mode control pin. When MODE is low, U/V signal can be applied through an external ac coupling capacitor to V _{IN P} . When MODE is high, Y signal can be applied through an external AC coupling capacitor to V _{IN P} . In this case, an internal circuitry clamps the sinc tip of the video input signal. When MODE is set to mid supply or left floating, input signal can be directly applied to the input without an AC coupling capacitor.
2,10,14	GND	Ground voltages.	13	GAIN	Three state gain control pin. GAIN tied low sets the input amplifier gain to 3/4 (0.75) and the output amplifier gain to 4/3 (1.333). When GAIN is tied high, the input amplifier gain is 3/2 (1.5) and the output amplifier gain is 4/3. When GAIN is set to mid supply or left to float, the input amplifier gain is 3/4 and the output gain is 8/3 (2.666). (See table below)
4	PULSE I/O	U/V clamp switch control input/output pin. When MODE is low, U/V clamp control pulse can be applied to this input pin. When MODE is high, the internal circuit generates a U/V clamp control signal to produce an output pulse at this pin. When MODE is floating, do not apply any voltage to this pin since it is internally tied low in this case. (See table below)	15,16	V _{OUT P} , V _{OUT M}	The output from the filter is derived from the V _{OUT P} pin with respect to the V _{OUT M} pin which is grounded typically. It can drive 1V _{PP} /75Ω (0.5V to 1.5V) or 2V _{PP} /150Ω (0.5V to 2.5V). If the output common-mode level needs to be increased, it can be done by raising the potential of V _{OUT M} . In this case, the output is measured from V _{OUT P} with respect to GND.
6,7	V _{IN P} , V _{IN M}	Input to the filter. The input voltage for the filter is applied to V _{IN P} pin with respect to V _{IN M} pin which is grounded. (With no connection to MODE pin, input signal range should be from V _{IN} = 0.5V to 1.5V when RANGE = Low, V _{IN} = 0V to 1V when RANGE = High). There is a 100μA internal current source connected to each of these inputs.	8	RANGE	Input signal range control when MODE is floating. When RANGE is low, the input signal range is 0.5V to 1.5V, when RANGE is tied high the input signal range is 0V to 1V.
9	R _{EXT}	Precision resistor to ground that defines the cutoff frequency of the filter. (Typical value = 10kΩ) 10% change in R _{EXT} produces a 10% change in f _C (Fig. 28).			

MODE	INPUT COUPLING	PULSE
Low	AC for U/V	Input
Float	DC	Internally biased
High	AC for Y	Output

Pulse Mode Table

GAIN SELECT	INPUT	INPUT BUFFER GAIN	OUTPUT BUFFER GAIN	OUTPUT	OPTIMIZES
Low	1V _{PP}	0.75	1.333	1V _{PP}	—
Float	1V _{PP}	0.75	2.666	2V _{PP}	Differential Phase & Gain
High	1V _{PP}	1.50	1.333	2V _{PP}	Noise

Gain Table

ML6424/ML6425

ABSOLUTE MAXIMUM RATINGS

Absolute maximum ratings are those values beyond which the device could be permanently damaged. Absolute maximum ratings are stress ratings only and functional device operation is not implied.

DC Supply Voltage -0.3V to 7V
Analog & Digital
Inputs/Outputs -0.3V to $V_{CC} + 0.3V$
Input current per pin -25mA to 25mA
Storage Temperature -65°C to 150°C
Maximum Junction Temperature 150°C

OPERATING CONDITIONS

Operating temperature range 0°C to 70°C
Operating supply range 5V ±5%

ELECTRICAL CHARACTERISTICS

Unless otherwise specified, $V_{CC} = 4.75$ to 5.25V, $T_A =$ Operating Temperature Range (Note 1).

PARAMETER	CONDITIONS	MIN	TYP	MAX	UNITS
Supply Current			100	150	mA
Input Current ($V_{IN P}$, $V_{IN M}$)	Sourcing out of the device	80	100	120	μA
Input Current Matching	Between $V_{IN P}$ and $V_{IN M}$ (tied to GND)		3.0	5	%
Low Frequency Gain	$V_{IN} = 100mV_{P-P}$ @ 100kHz	-0.2	0.0	0.2	dB
Passband Ripple	$100Hz < f_{IN} < f_C$	-0.25		0.25	dB
Differential Gain (RANGE = High)	$V_{IN}: 1.0V \pm 0.5V$, @ 3.58 or 4.43MHz		0.5	1	%
Differential Phase (RANGE = High)	$V_{IN}: 1.0V \pm 0.5V$, @ 3.58 or 4.43MHz		0.5	1	Degree
Dynamic Input Signal Range (MODE = Float)	RANGE = Low	0.5		1.5	V
	RANGE = High	0		1	V
Output Noise (GAIN = High)	Bw: 30MHz, ML6424-1		1.7	2.3	mV _{RMS}
	Bw: 30MHz, ML6424-2		1.3	1.9	mV _{RMS}
	Bw: 30MHz, ML6425-1		1.7	2.3	mV _{RMS}
	Bw: 30MHz, ML6425-2		1.3	1.9	mV _{RMS}
Corner Frequency (f_C) (±0.25dB)	ML6424-1 or ML6425-1	5.23	5.50	5.78	MHz
	ML6424-2 or ML6425-2	2.61	2.75	2.89	MHz
Stopband Loss (ML6424-1, -2)	$f_{IN} > 1.45 \times$ corner frequency	35	38		dB
Stopband Loss (ML6425-1, -2)	$f_{IN} > 1.45 \times$ corner frequency	30	33		dB
Peak Overshoot and Ringing	2T, 0.7V _{P-P} pulse			1	%
Composite Chroma/Luma Delay	$T_D(\text{subcarrier}) - T_D(0)$; $f_C = 5.5MHz$			20	ns
Output Short Circuit Current	$V_{OUT P}$ to GND while $V_{OUT M} = GND$		45		mA
Load Capacitance	$V_{OUT P}$ to GND		35		pF
Logic Input Low (V_{IL})	RANGE			0.8	V
Logic Input High (V_{IH})	RANGE	$V_{CC} - 0.8$			V
Logic Input Low (I_{IL})	$V_{IN} = GND$	-1			μA
Logic Input High (I_{IH})	$V_{IN} = V_{CC}$			1	μA

Note 1: Limits are guaranteed by 100% testing, sampling, or correlation with worst case conditions.

Note 2: Digital Inputs: All inputs are high impedance 1μA leakage, with MAX input voltage levels of 0.8V from each supply

FUNCTIONAL DESCRIPTION

The ML6424 and ML6425 are monolithic CCIR601 continuous time video filters, designed for broadcast and professional luminance and chrominance antialias and reconstruction applications. They are fabricated using Micro Linear's 1.5 μ , 4 GHz BiCMOS process. The filter incorporates an input amplifier, programmable gain of 1x or 2x set by the GAIN pin, a fifth order lowpass filter, a third order allpass filter, and an output amplifier capable of driving 75 Ω to ground. The ML6425 provides $\sin x/x$ equalization.

The ML6424-1 is intended for application as luminance antialias processing, the ML6424-2 for chrominance antialias, the ML6425-1 for luma reconstruction, and the ML6425-2 for chroma reconstruction.

Input signals can be applied either through an AC coupling capacitor (MODE = High/Low) or directly to the input pin (MODE = float). With MODE = High, Y-Channel signal

can be applied to the input and the PULSE I/O pin generates a clamping pulse for the U/V channel. When MODE = Low, U/V channel signal can be applied to the input. In this case, the PULSE I/O pin can take the pulse signal generated from the PULSE I/O pin of the other chip in the Y-channel. In the case of direct coupling, RANGE should be adjusted according to the input signal range. When RANGE is low, the input signal range is 0.5V to 1.5V. When the input signal goes down to 0V, RANGE should be tied high. In this case, an offset is added to the input so that the filter can process the 0V DC level.

The output amplifier is designed to drive up to 20mA peak into a 75 Ω load, or 17mA peak into a 150 Ω load. Load resistance less than 75 Ω and/or output voltage above 1.5V into 75 Ω (2.5V into 150 Ω) may cause signal distortion.

Good high frequency decoupling is required between each power supply pin and ground, otherwise oscillations and/or excessive crosstalk may occur.

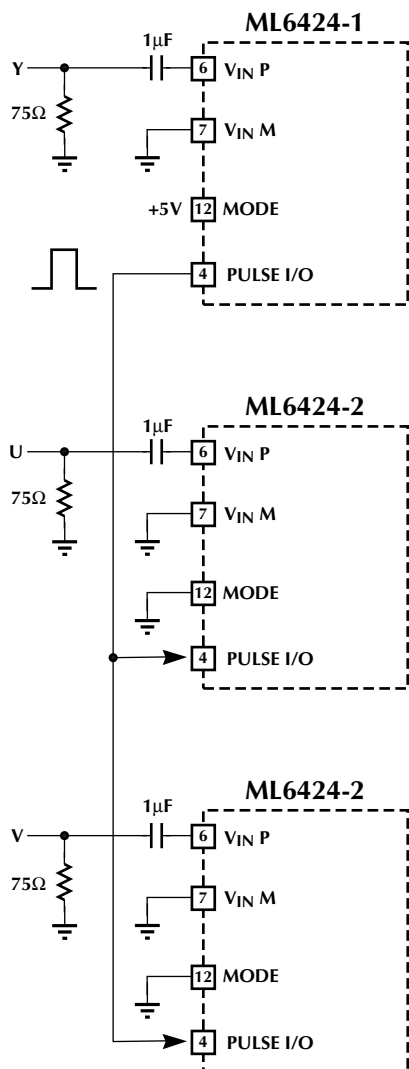

Figure 1. YUV Filter with Sync on Y Input and Auto Clamp On

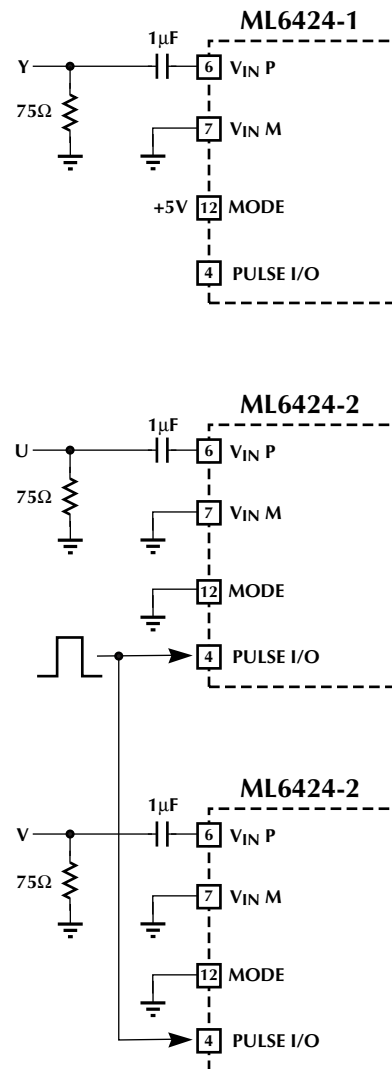

Figure 2. YUV Filter with External Sync for U/V

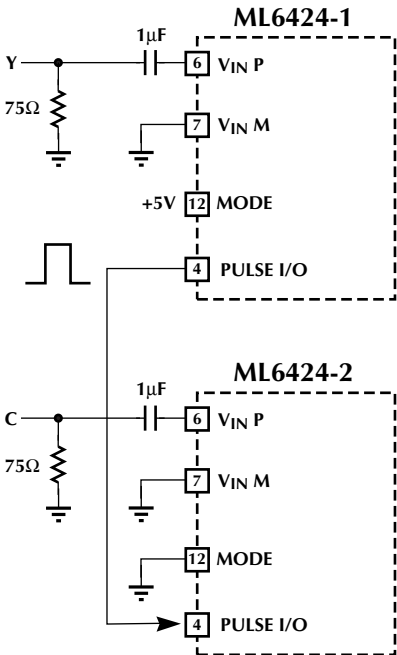

Figure 3. Y/C Filter

ML6424-1 RESPONSE CURVES

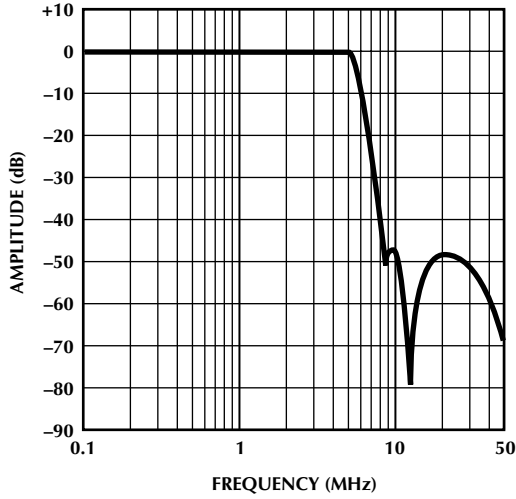

Figure 4. Amplitude vs Frequency

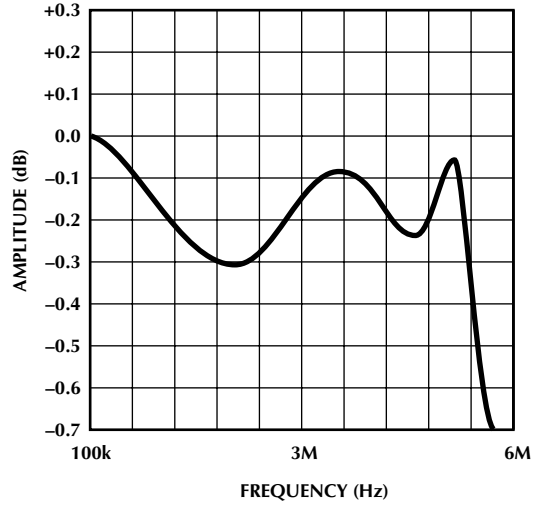

Figure 5. Amplitude vs Frequency

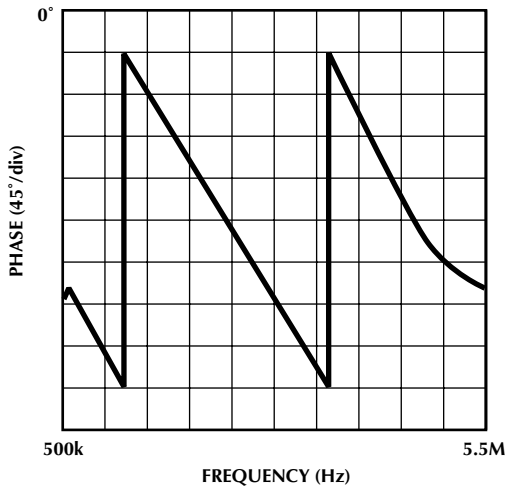

Figure 6. Phase vs Linear Frequency

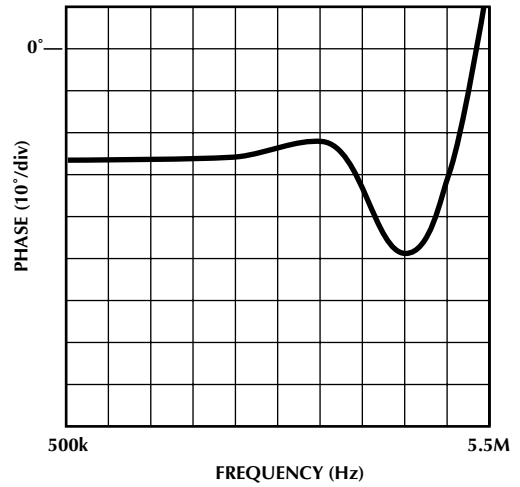

Figure 7. Deviation from Linear Phase

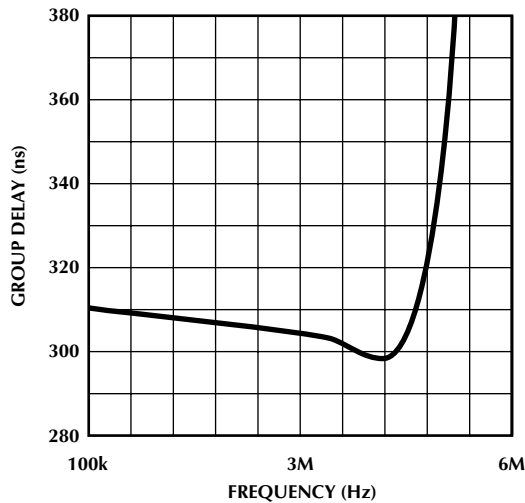

Figure 8. Group Delay vs Frequency

ML6424-2 RESPONSE CURVES

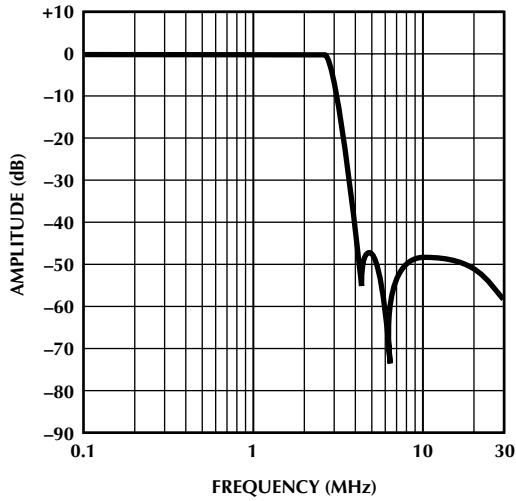

Figure 9. Amplitude vs Frequency

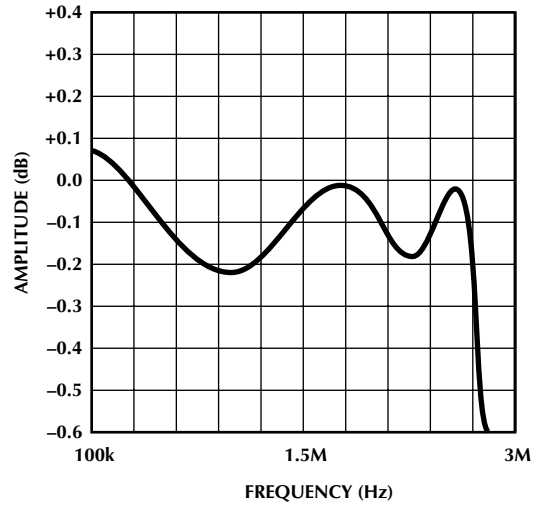

Figure 10. Amplitude vs Frequency

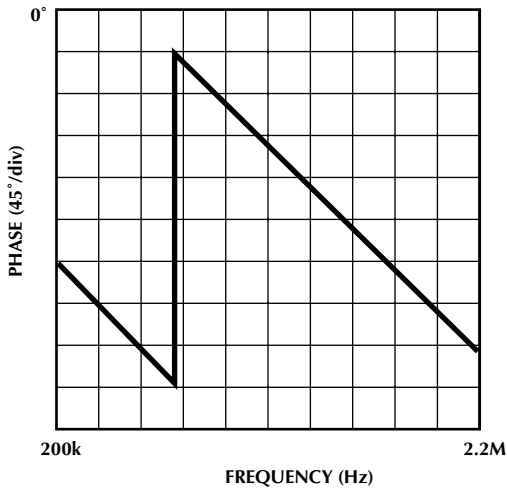

Figure 11. Phase vs Linear Frequency

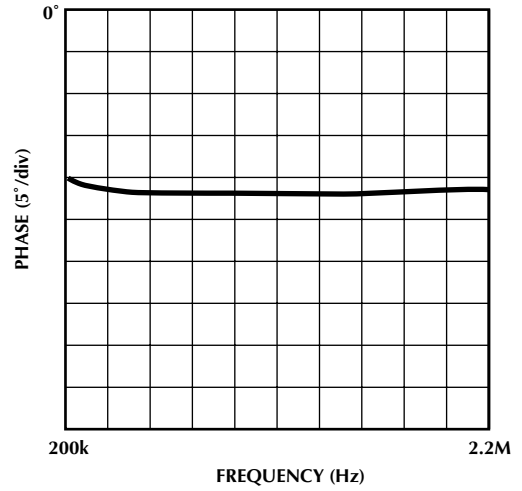

Figure 12. Deviation from Linear Phase

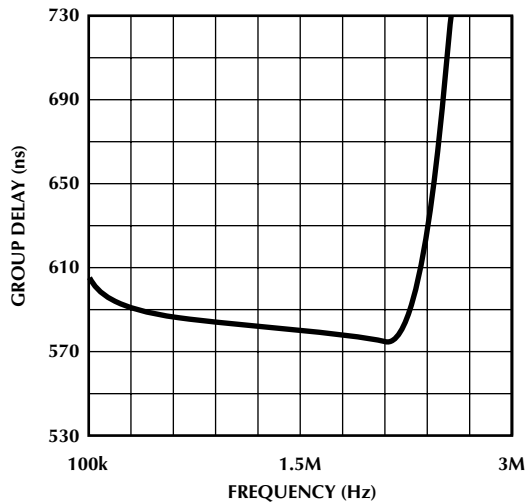

Figure 13. Group Delay vs Frequency

ML6425-1 RESPONSE CURVES

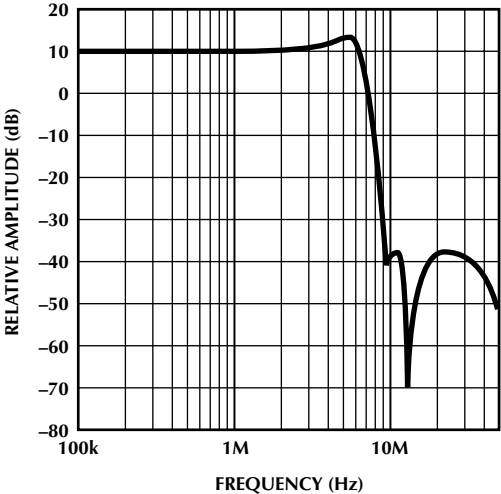

Figure 14. Amplitude vs Frequency

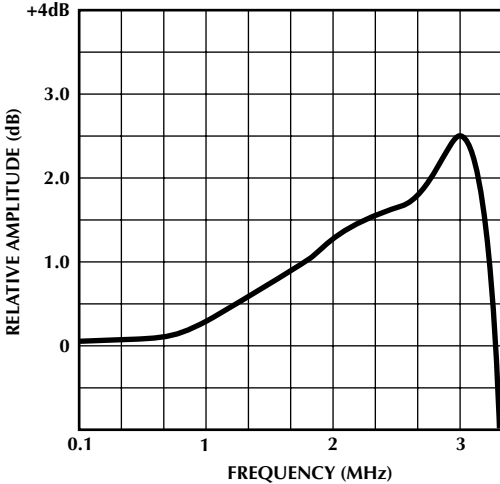

Figure 15. Amplitude vs Frequency

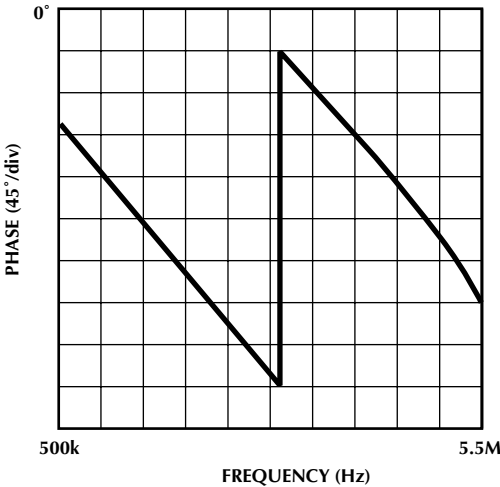

Figure 16. Phase vs Frequency

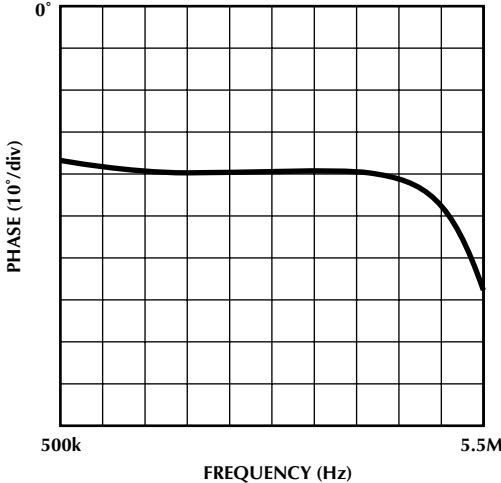

Figure 17. Deviation from Linear Phase

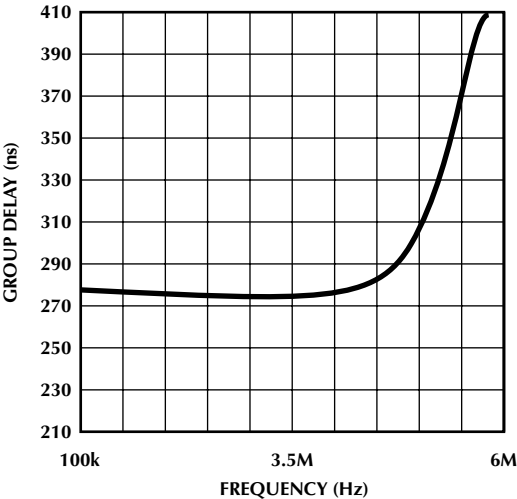

Figure 18. Group Delay vs Frequency

ML6425-2 RESPONSE CURVES

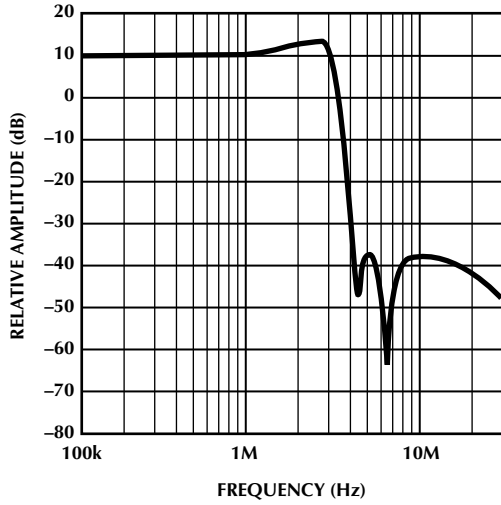

Figure 19. Amplitude vs Frequency

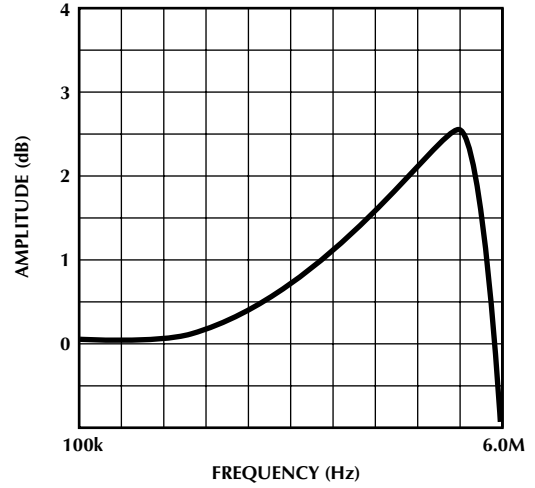

Figure 20. Amplitude vs Frequency

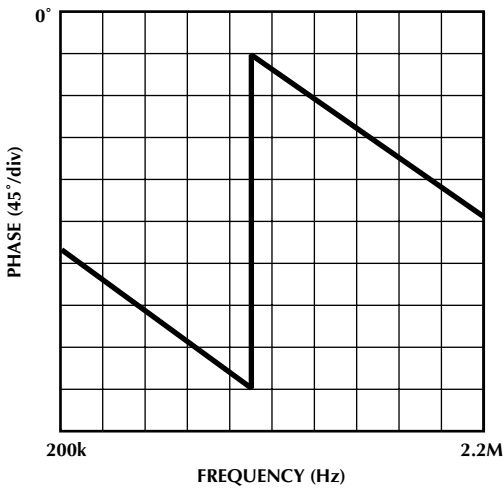

Figure 21. Phase vs Linear Frequency

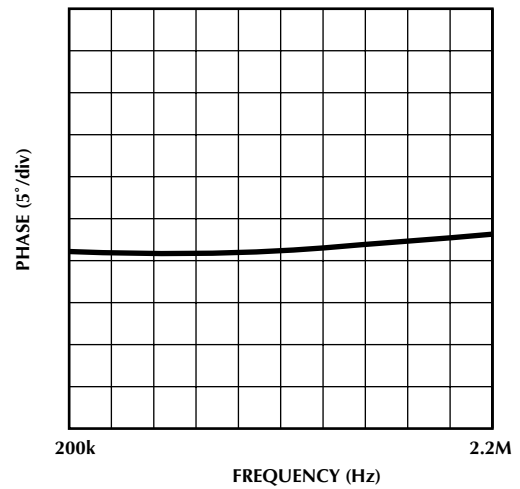

Figure 22. Deviation from Linear vs Phase

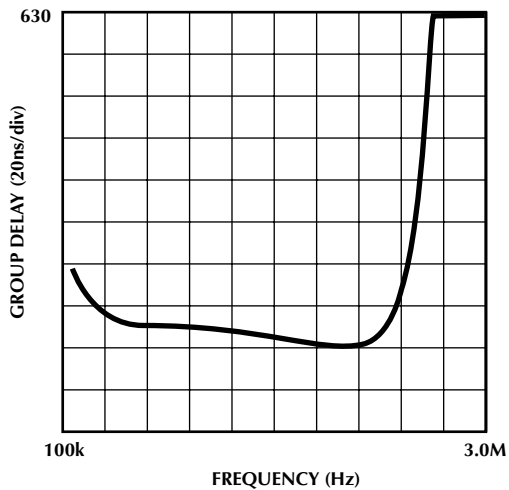

Figure 23. Group Delay vs Frequency

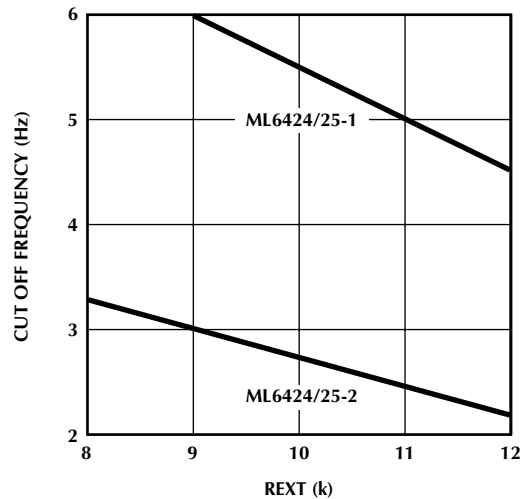

Figure 24. Frequency vs R_{EXT}

ML6425-2 RESPONSE CURVES

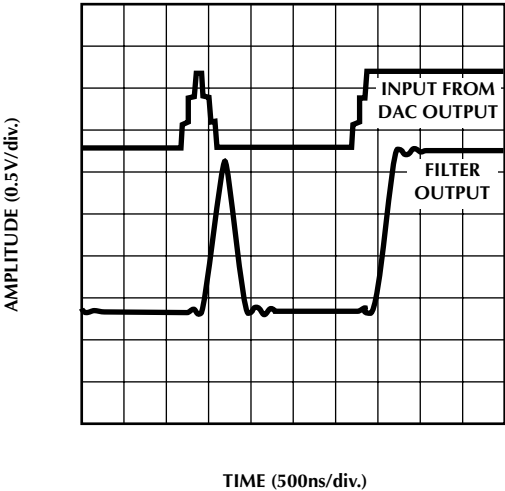
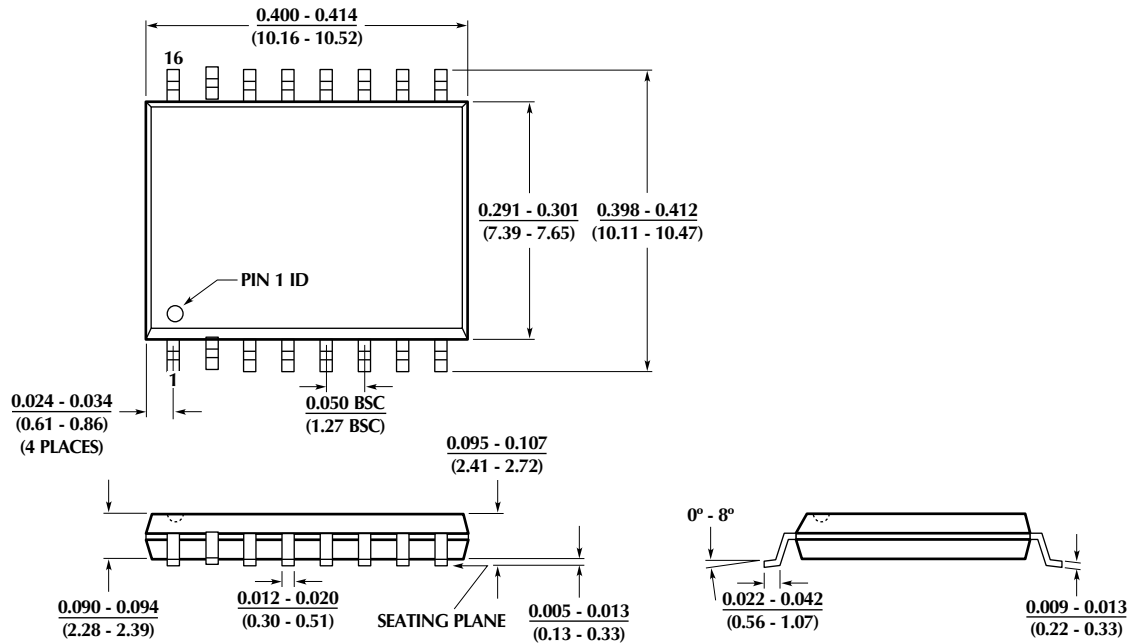

Figure 25. Transient Response

ML6424/ML6425

PHYSICAL DIMENSIONS inches (millimeters)

Package: S16W 16-Pin Wide SOIC



ORDERING INFORMATION

PART NUMBER	FREQ	SIN X/X	TEMPERATURE RANGE	PACKAGE
ML6424-1	5.5	NO	0-C to 70-C	16-Pin SOIC (S16W) (Obsolete)
ML6424-2	2.75	NO	0-C to 70-C	16-Pin SOIC (S16W)
ML6425-1	5.5	YES	0-C to 70-C	16-Pin SOIC (S16W) (Obsolete)
ML6425-2	2.75	YES	0-C to 70-C	16-Pin SOIC (S16W)

© Micro Linear 1997  **Micro Linear** is a registered trademark of Micro Linear Corporation

Products described herein may be covered by one or more of the following patents: 4,897,611; 4,964,026; 5,027,116; 5,281,862; 5,283,483; 5,418,502; 5,508,570; 5,510,727; 5,523,940; 5,546,017; 5,559,470; 5,565,761; 5,594,376; 5,592,128. Other patents are pending.

Micro Linear reserves the right to make changes to any product herein to improve reliability, function or design. Micro Linear does not assume any liability arising out of the application or use of any product described herein, neither does it convey any license under its patent right nor the rights of others. The circuits contained in this data sheet are offered as possible applications only. Micro Linear makes no warranties or representations as to whether the illustrated circuits infringe any intellectual property rights of others, and will accept no responsibility or liability for use of any application herein. The customer is urged to consult with appropriate legal counsel before deciding on a particular application.

2092 Concourse Drive
San Jose, CA 95131
Tel: 408/433-5200
Fax: 408/432-0295