MINI ANALOG SERIES **S-89713B Series**
LOW INPUT OFFSET VOLTAGE CMOS OPERATIONAL AMPLIFIER

The mini-analog series is a group of ICs that incorporate a general purpose analog circuit in a small package.

The S-89713B Series is an auto-zero operation, zero-drift operational amplifier that has I/O of low input offset voltage and Rail-to-Rail*¹. This IC is suitable for applications requiring less offset voltage.

The S-89713B Series is dual operational amplifier (with 2 circuits).

*1. Rail-to-Rail is a trademark of Motorola, Inc.

■ Features

- Low input offset voltage : 10 μ V Max.
- Low voltage operation : $V_{DD} = 2.65$ V to 5.5 V
- Low current consumption : $I_{DD} = 165$ μ A Typ. (for 1 circuit)
: $I_{DD} = 330$ μ A Typ. (for 2 circuits)
- No external capacitors required for internal phase compensation
- Rail-to-Rail I/O
- Small packages: : SNT-8A, TMSOP-8
- Lead-free product

■ Application

- Various sensor interface
- High-accuracy current detection
- Strain gauge amplifiers
- Game
- Various electric devices

■ Packages

Package Name	Drawing Code			
	Package	Tape	Reel	Land
SNT-8A	PH008-A	PH008-A	PH008-A	PH008-A
TMSOP-8	FM008-A	FM008-A	FM008-A	–

■ Block Diagram

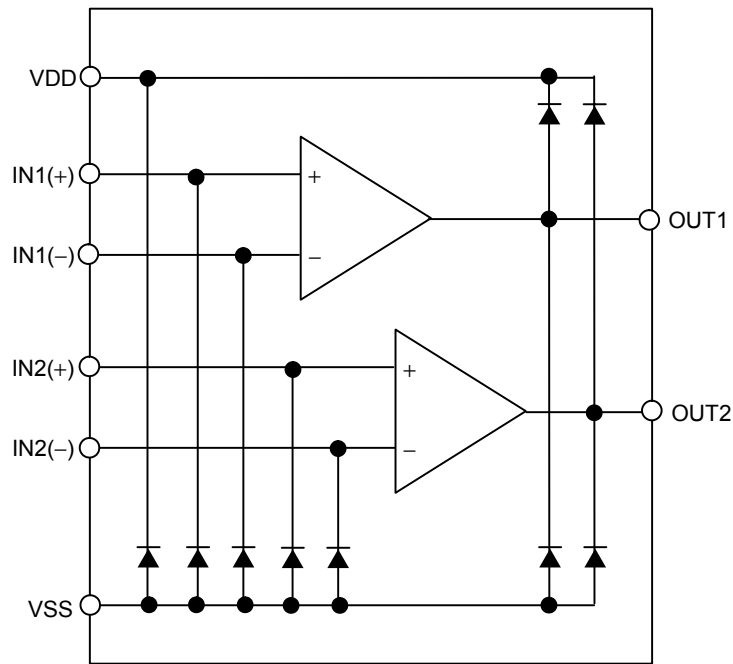

Figure 1

■ Product Name Structure

Users can select the product type for the S-89713B Series. Regarding the contents of the product name, refer to “1. Product name”. Regarding the product type, refer to “2. Product name list”.

1. Product name

(1) SNT-8A

S-89713B - I8T1 G

└──────────┬──────────┘
 Product name (abbreviation) and IC packing specifications*1
 I8T1 : SNT-8A, Tape

*1. Refer to the tape specifications.

(2) TMSOP-8

S-89713B - K8T2 U

└──────────┬──────────┘
 Product name (abbreviation) and IC packing specifications*1
 K8T2 : TMSOP-8, Tape

*1. Refer to the tape specifications.

2. Product list

Table 1

Product name	Package
S-89713B-I8T1G	SNT-8A
S-89713B-K8T2U	TMSOP-8

■ Pin Configurations

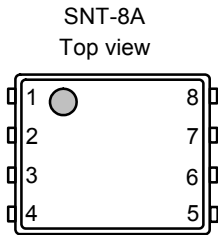

Figure 2

Table 2

Pin No.	Symbol	Description
1	OUT1	Output pin 1
2	IN1(-)	Inverted input pin 1
3	IN1(+)	Non-inverted input pin 1
4	VSS	GND pin
5	IN2(+)	Non-inverted input pin 2
6	IN2(-)	Inverted input pin 2
7	OUT2	Output pin 2
8	VDD	Positive power supply pin

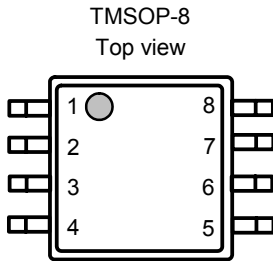

Figure 3

Table 3

Pin No.	Symbol	Description
1	OUT1	Output pin 1
2	IN1(-)	Inverted input pin 1
3	IN1(+)	Non-inverted input pin 1
4	VSS	GND pin
5	IN2(+)	Non-inverted input pin 2
6	IN2(-)	Inverted input pin 2
7	OUT2	Output pin 2
8	VDD	Positive power supply pin

■ Absolute Maximum Ratings

Table 4

(Ta = +25°C unless otherwise specified)

Parameter	Symbol	Absolute Maximum Rating	Unit	
Power supply voltage	V _{DD}	V _{SS} -0.3 to V _{SS} +6.0	V	
Input voltage	V _{IN(+)} , V _{IN(-)}	V _{SS} -0.3 to V _{DD} +0.3	V	
Output voltage	V _{OUT}	V _{SS} -0.3 to V _{DD} +0.3	V	
Differential input voltage	V _{IND}	±5.5	V	
Output pin current	I _{SOURCE}	10.0	mA	
	I _{SINK}	10.0	mA	
Power dissipation	SNT-8A	P _D	450 ^{*1}	mW
	TMSOP-8		650 ^{*1}	mW
Operating ambient temperature	T _{opr}	-40 to +85	°C	
Storage temperature	T _{stg}	-55 to +125	°C	

*1. When mounted on board
 [Mounted board]

- (1) Board size: 114.3 mm × 76.2 mm × t1.6 mm
- (2) Board name: JEDEC STANDARD51-7

Caution The absolute maximum ratings are rated values exceeding which the product could suffer physical damage. These values must therefore not be exceeded under any conditions.

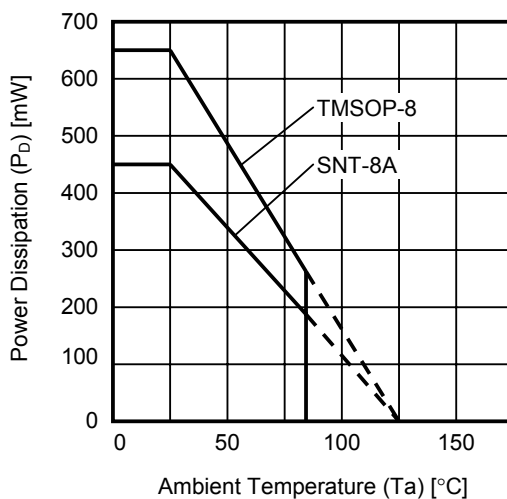

Figure 4 Power Dissipation of Package (When Mounted on Board)

■ Electrical Characteristics

Table 5

DC Electrical Characteristics (Ta = +25°C, V_{DD} = 3.0 V unless otherwise specified)

Parameter	Symbol	Conditions	Min.	Typ.	Max.	Unit	Test Circuit
Operation power supply voltage range	V _{DD}	–	2.65	3.00	5.50	V	–
Current consumption (for 2 circuits)	I _{DD}	V _{CMR} = V _{OUT} = V _{DD} /2	–	330	380	μA	5
Input offset voltage	V _{IO}	V _{CMR} = V _{DD} /2	–10	±1	+10	μV	1
Input offset voltage drift	$\frac{\Delta V_{IO}}{\Delta T_a}$	V _{CMR} = V _{DD} /2	–	±0.1	–	μV/°C	1
Input offset current	I _{IO}	–	–	±140	–	pA	–
Input bias current	I _{BIAS}	–	–	±70	–	pA	–
Common-mode input voltage range	V _{CMR}	–	V _{SS} –0.1	–	V _{DD} +0.1	V	2
Voltage gain (open loop)	A _{VOL}	V _{SS} +0.1 V ≤ V _{OUT} ≤ V _{DD} –0.1 V V _{CMR} = V _{DD} /2, R _L = 10 kΩ	110	130	–	dB	8
Maximum output swing voltage	V _{OH}	R _L = 10 kΩ	2.9	–	–	V	3
	V _{OL}	R _L = 10 kΩ	–	–	0.1	V	4
Common-mode input signal rejection ratio	CMRR	V _{SS} –0.1 V ≤ V _{CMR} ≤ V _{DD} +0.1 V	106	130	–	dB	2
Power supply voltage rejection ratio	PSRR	V _{DD} = 2.65 V to 5.50 V	106	120	–	dB	1
Source current	I _{SOURCE}	V _{OUT} = V _{DD} –0.1 V	1.3	1.6	–	mA	6
Sink current	I _{SINK}	V _{OUT} = 0.1 V	1.6	2.0	–	mA	7

Table 6

AC Electrical Characteristics (Ta = +25°C, V_{DD} = 3.0 V unless otherwise specified)

Parameter	Symbol	Conditions	Min.	Typ.	Max.	Unit
Slew rate	SR	R _L = 1.0 MΩ, C _L = 15 pF (Refer to Figure 13)	–	0.16	–	V/μs
Gain-bandwidth product	GBP	C _L = 0 pF	–	240	–	kHz

■ Test Circuit (Per Circuit)

1. Power supply voltage rejection ratio, input offset voltage

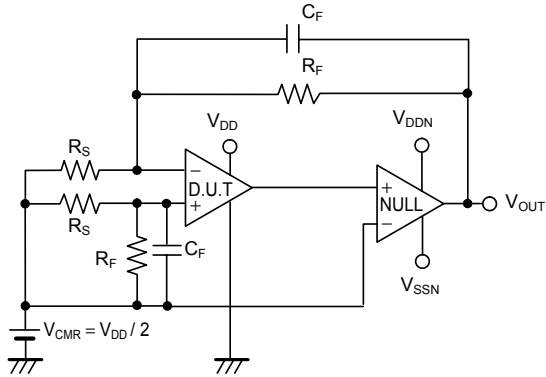

Figure 5

• Power supply voltage rejection ratio (PSRR)

The power supply voltage rejection ratio (PSRR) can be calculated by the following expression, with V_{OUT} measured at each V_{DD} .

Test conditions:

When $V_{DD} = 2.65\text{ V}$: $V_{DD} = V_{DD1}$, $V_{OUT} = V_{OUT1}$,

When $V_{DD} = 5.5\text{ V}$: $V_{DD} = V_{DD2}$, $V_{OUT} = V_{OUT2}$

$$PSRR = 20 \log \left(\left| \frac{V_{DD1} - V_{DD2}}{\left(V_{OUT1} - \frac{V_{DD1}}{2} \right) - \left(V_{OUT2} - \frac{V_{DD2}}{2} \right)} \right| \times \frac{R_F + R_S}{R_S} \right)$$

• Input offset voltage (V_{IO})

$$\left(V_{OUT} - \frac{V_{DD}}{2} \right) \times \frac{R_S}{R_F + R_S}$$

2. Common-mode input signal rejection ratio, common-mode input voltage range

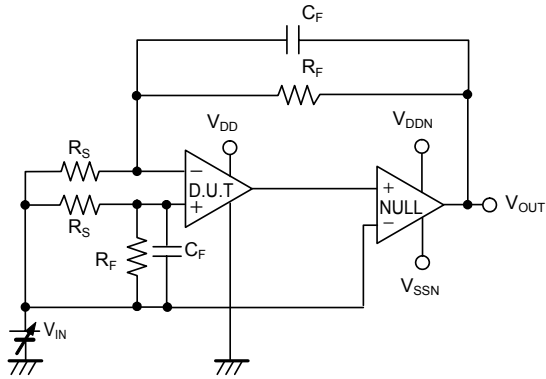

Figure 6

• Common-mode input signal rejection ratio (CMRR)

The common-mode input signal rejection ratio (CMRR) can be calculated by the following expression, with V_{OUT} measured at each V_{IN} .

Test conditions:

When $V_{IN} = V_{CMR\ Max.}$: $V_{IN} = V_{IN1}$, $V_{OUT} = V_{OUT1}$,

When $V_{IN} = V_{CMR\ Min.}$: $V_{IN} = V_{IN2}$, $V_{OUT} = V_{OUT2}$

$$CMRR = 20 \log \left(\left| \frac{V_{IN1} - V_{IN2}}{\left(V_{OUT1} - V_{IN1} \right) - \left(V_{OUT2} - V_{IN2} \right)} \right| \times \frac{R_F + R_S}{R_S} \right)$$

• Common-mode input voltage range (V_{CMR})

The common-mode input voltage range is the range of V_{IN} in which V_{OUT} satisfies the common-mode input signal rejection ratio specifications.

3. Maximum output swing voltage (V_{OH})

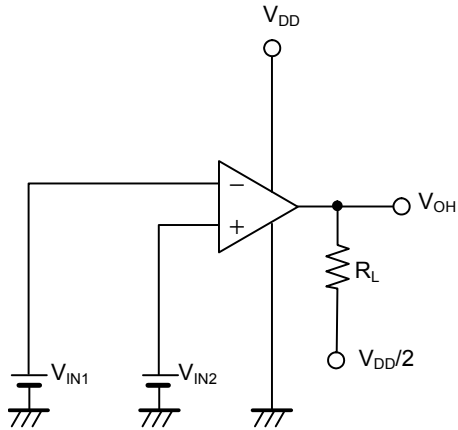

Figure 7

• **Maximum output swing voltage (V_{OH})**

Test conditions:

$$V_{IN1} = \frac{V_{DD}}{2} - 0.1 \text{ V}$$

$$V_{IN2} = \frac{V_{DD}}{2} + 0.1 \text{ V}$$

$$R_L = 10 \text{ k}\Omega$$

4. Maximum output swing voltage (V_{OL})

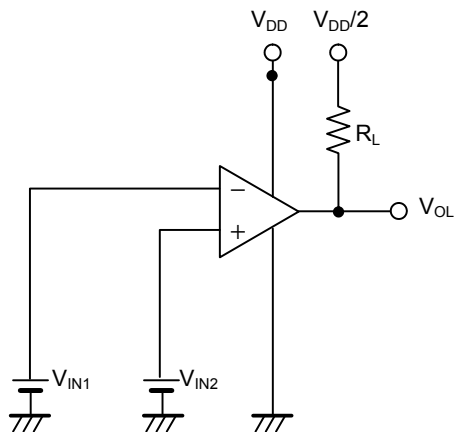

Figure 8

• **Maximum output swing voltage (V_{OL})**

Test conditions:

$$V_{IN1} = \frac{V_{DD}}{2} + 0.1 \text{ V}$$

$$V_{IN2} = \frac{V_{DD}}{2} - 0.1 \text{ V}$$

$$R_L = 10 \text{ k}\Omega$$

5. Current consumption

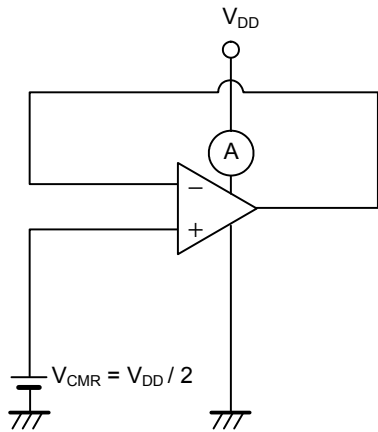

Figure 9

- Current consumption (I_{DD})

6. Source current

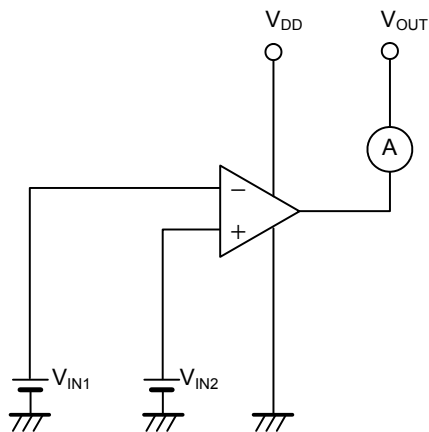

Figure 10

- Source current (I_{SOURCE})

Test conditions:

$$V_{OUT} = V_{DD} - 0.1 \text{ V}$$

$$V_{IN1} = \frac{V_{DD}}{2} - 0.1 \text{ V}$$

$$V_{IN2} = \frac{V_{DD}}{2} + 0.1 \text{ V}$$

7. Sink current

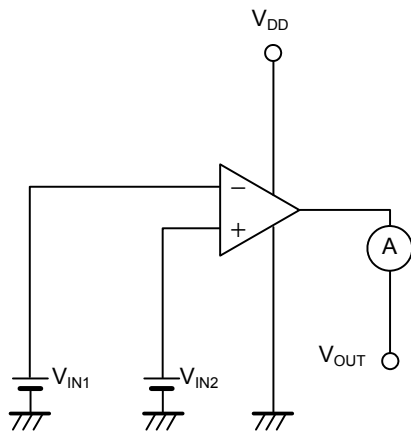

Figure 11

- Sink current (I_{SINK})

Test conditions:

$$V_{OUT} = 0.1 \text{ V}$$

$$V_{IN1} = \frac{V_{DD}}{2} + 0.1 \text{ V}$$

$$V_{IN2} = \frac{V_{DD}}{2} - 0.1 \text{ V}$$

8. Voltage gain (open loop)

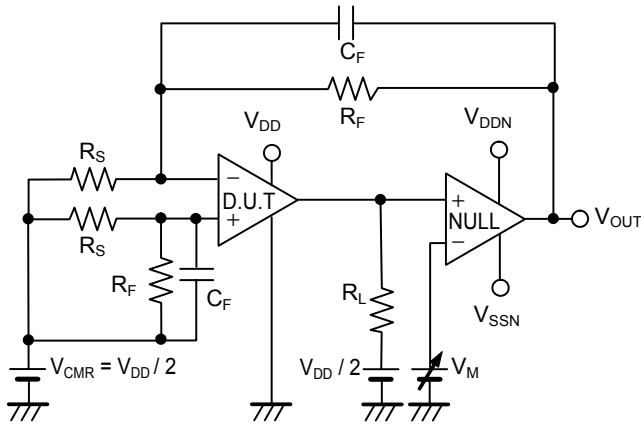

Figure 12

• **Voltage-gain (open loop) (A_{VOL})**

The voltage gain (A_{VOL}) can be calculated by the following expression, with measured V_{OUT} at each V_M .

Test conditions:

When $V_M = V_{DD} - 0.1 V$: $V_M = V_{M1}$, $V_{OUT} = V_{OUT1}$,

When $V_M = 0.1 V$: $V_M = V_{M2}$, $V_{OUT} = V_{OUT2}$

$$A_{VOL} = 20 \log \left(\left| \frac{V_{M1} - V_{M2}}{V_{OUT1} - V_{OUT2}} \right| \times \frac{R_F + R_S}{R_S} \right)$$

$R_L = 10 \text{ k}\Omega$

9. Slew rate (SR)

Measured by the voltage follower circuit.

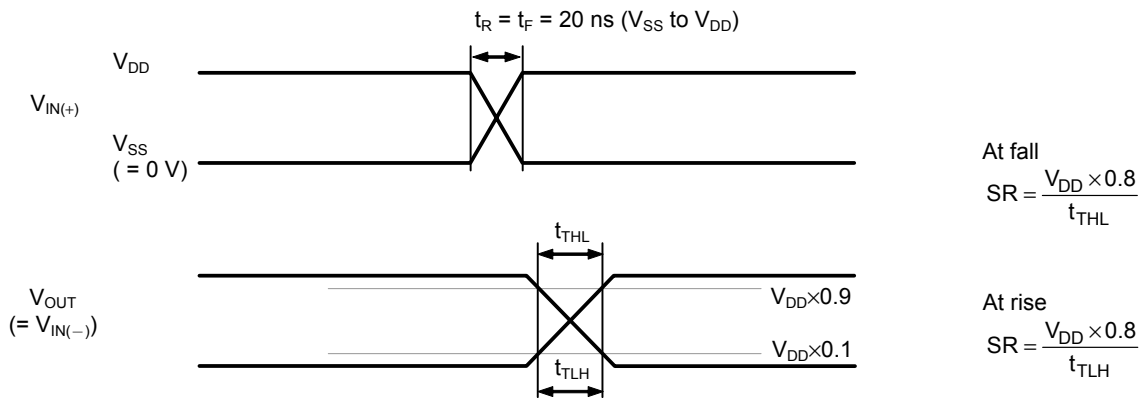

Figure 13

■ Usage Example

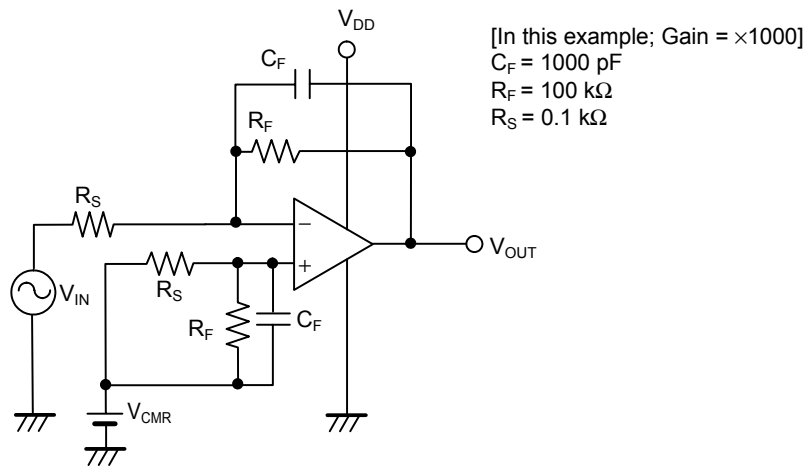

Figure 14

■ **Precautions**

- Do not apply an electrostatic discharge to this IC that exceeds performance ratings of the built-in electrostatic protection circuit.
- SII claims no responsibility for any disputes arising out of or in connection with any infringement by products including this IC of patents owned by a third party.
- Use this IC with the output voltage 10 mA or less.
- This IC operates stably even directly connecting a load capacitance 150 pF or less to the output pin, as seen in **Figure 15**. When using a load capacitance 150 pF or larger, set a resistor 470 Ω or more, as seen in **Figure 16**. In case of connecting a filter for noise prevention, and using a load capacitance 150 pF or more, also set a resistor 470 Ω or more as seen in **Figure 17**.

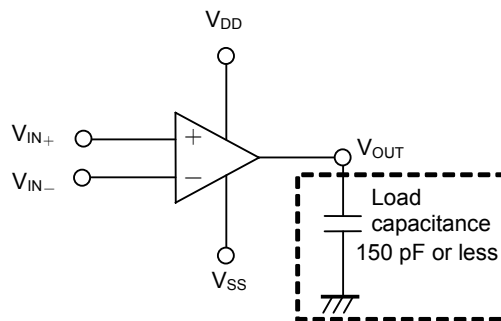

Figure 15

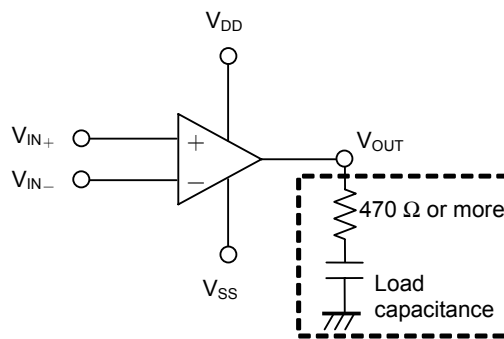

Figure 16

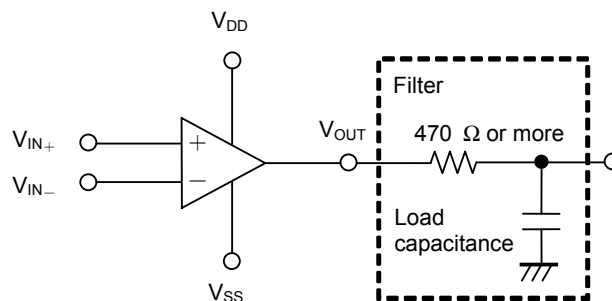
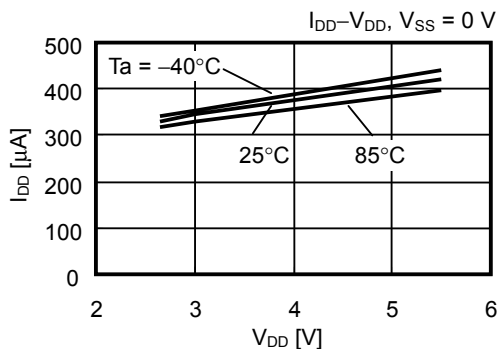

Figure 17

Caution The above connection diagram and constant will not guarantee successful operation. Perform through evaluation using the actual application to set the constant.

■ Characteristics (Typical Data)

1. Current consumption (for 2 circuits) vs. Power supply voltage



2. Voltage gain vs. Frequency

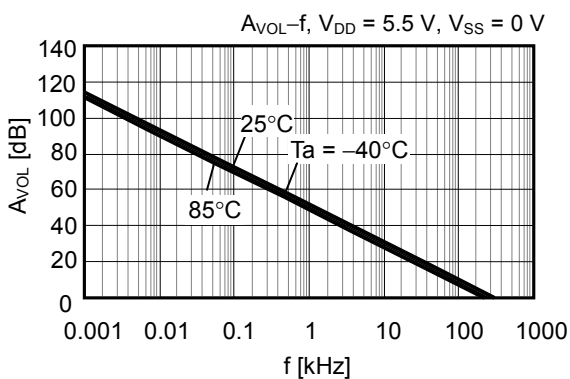
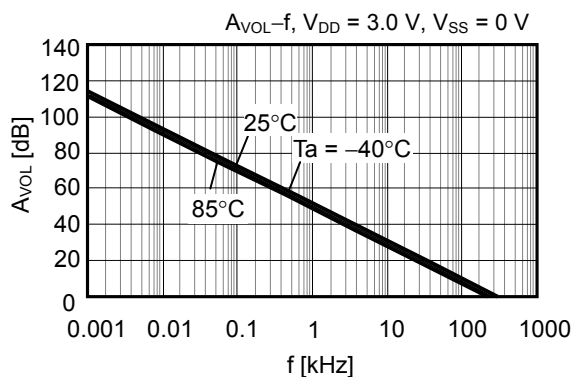
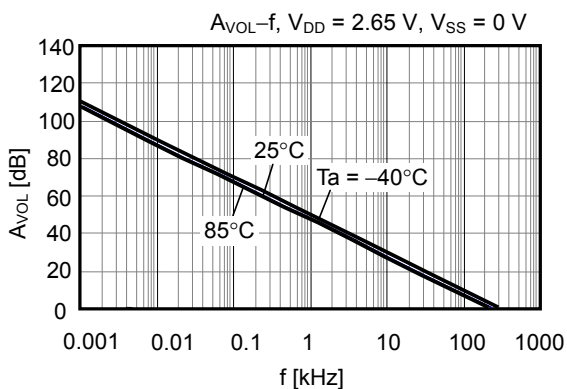

3. Output current

3.1 I_{SOURCE} vs. Power supply voltage

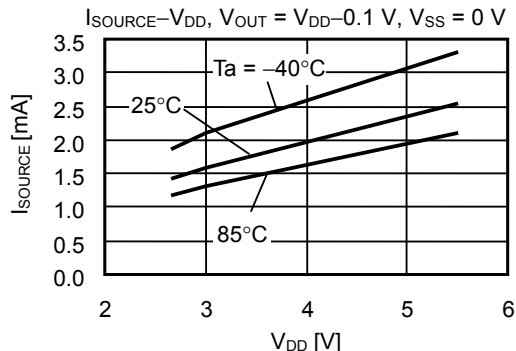

3.2 I_{SINK} vs. Power supply voltage

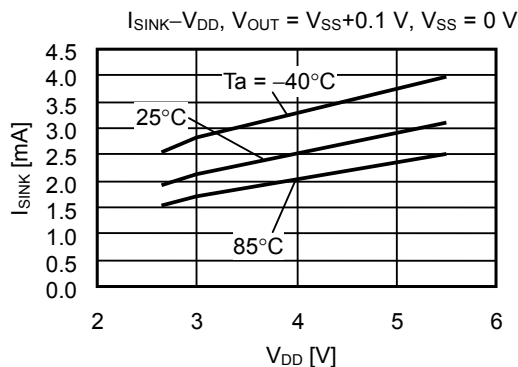

3.3 Output voltage (V_{OUT}) vs. I_{SOURCE} characteristics

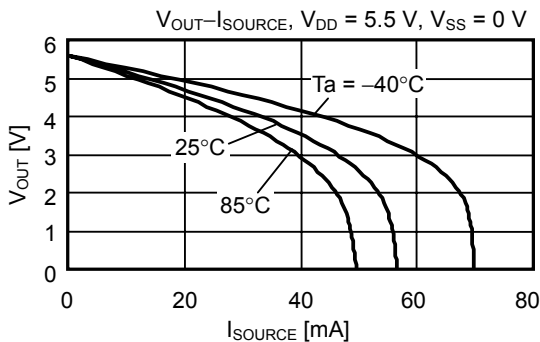
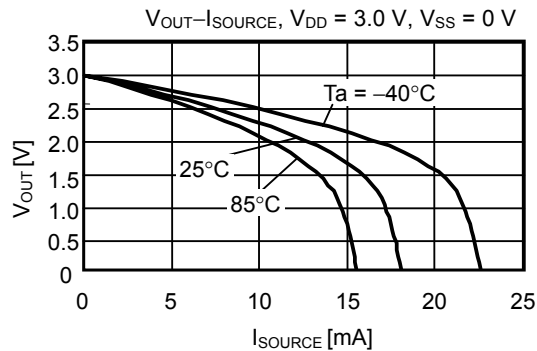
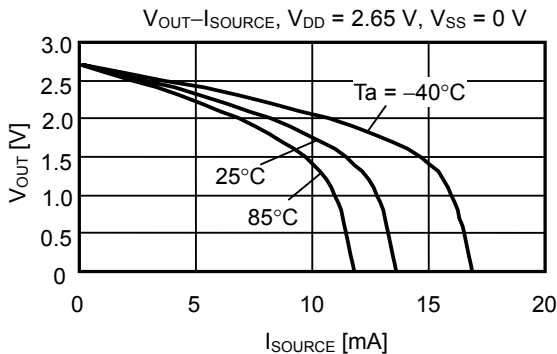

3.4 Output voltage (V_{OUT}) vs. I_{SINK}

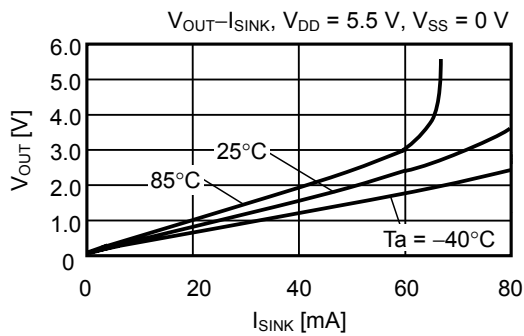
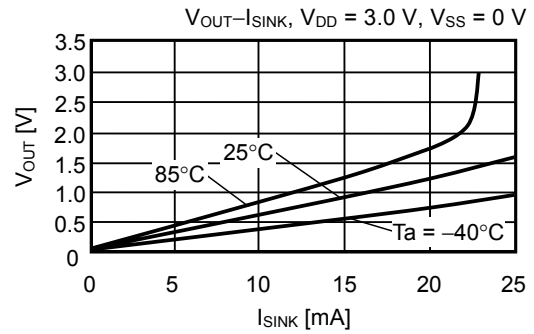
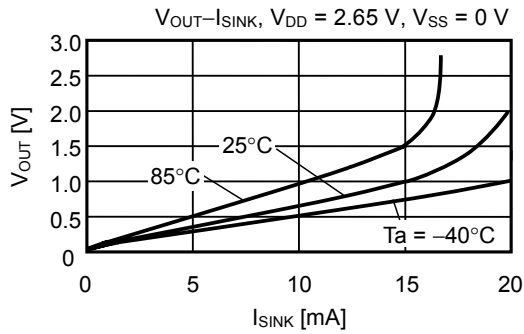

4. Input-referred noise voltage vs. Frequency characteristics

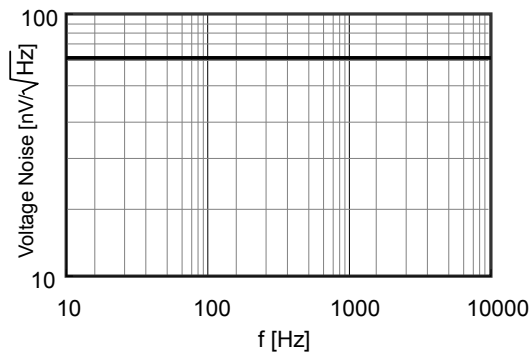

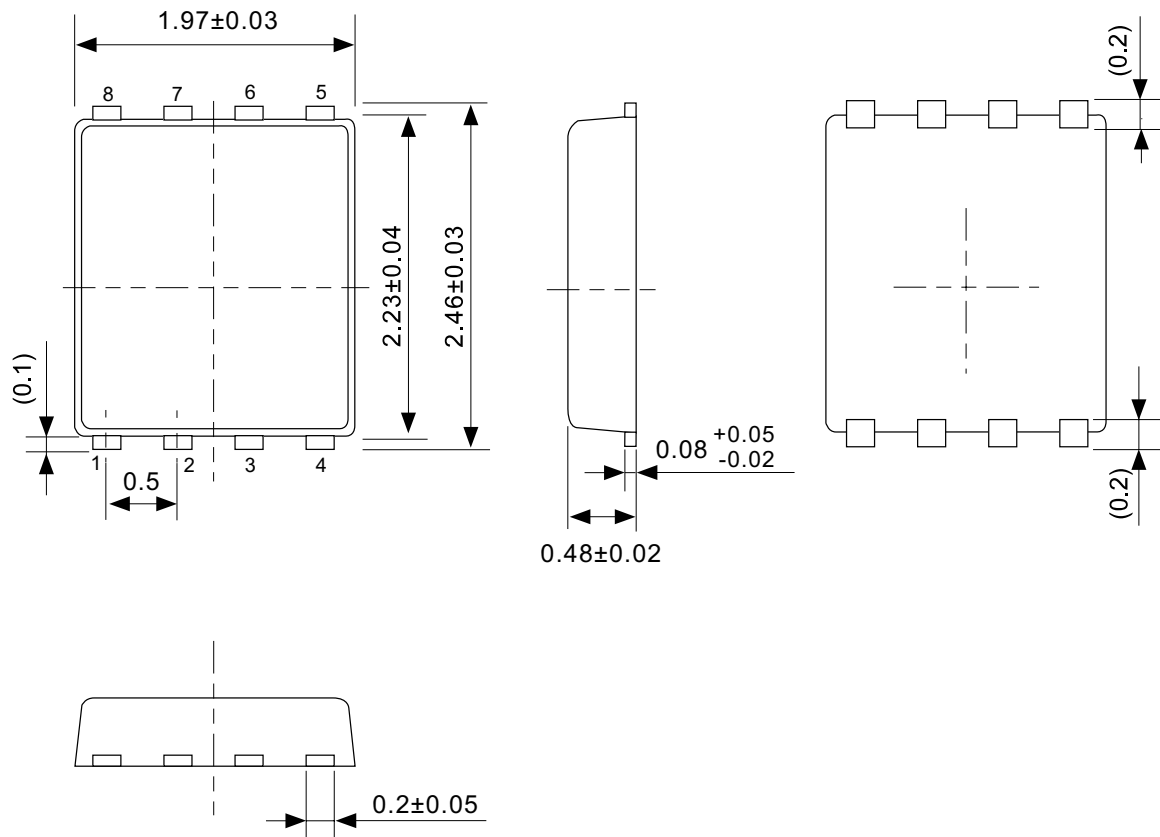

No. PH008-A-P-SD-2.0

TITLE	SNT-8A-A-PKG Dimensions
No.	PH008-A-P-SD-2.0
SCALE	
UNIT	mm
Seiko Instruments Inc.	

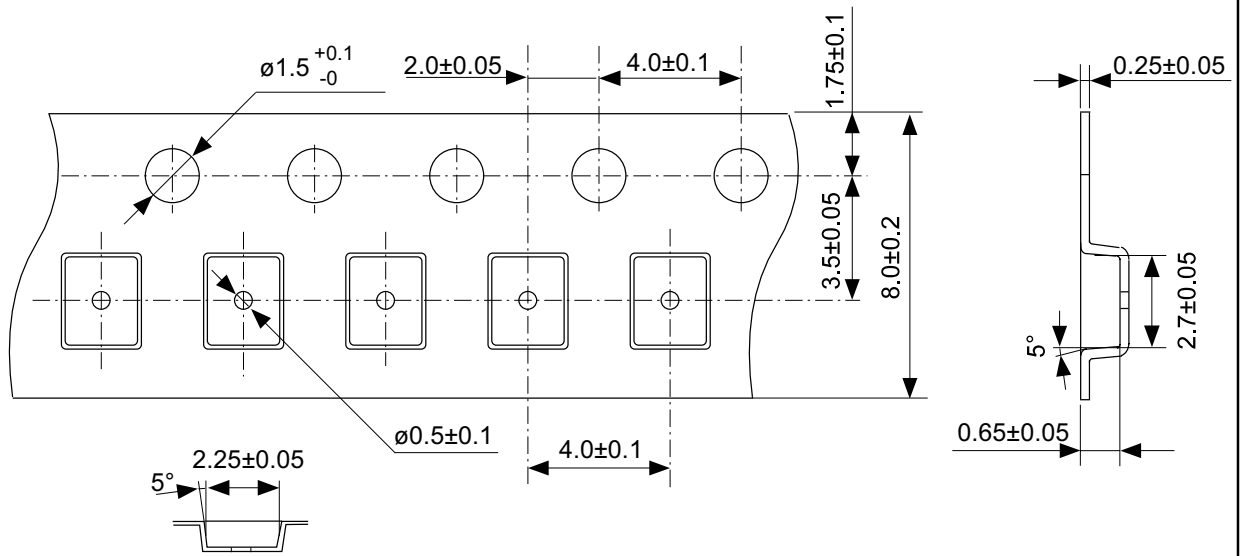

4 3 2 1
5 6 7 8

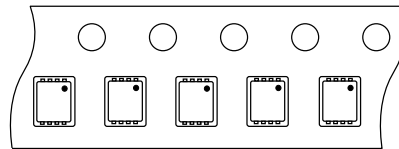

Feed direction

No. PH008-A-C-SD-1.0

TITLE	SNT-8A-A-Carrier Tape
No.	PH008-A-C-SD-1.0
SCALE	
UNIT	mm
Seiko Instruments Inc.	

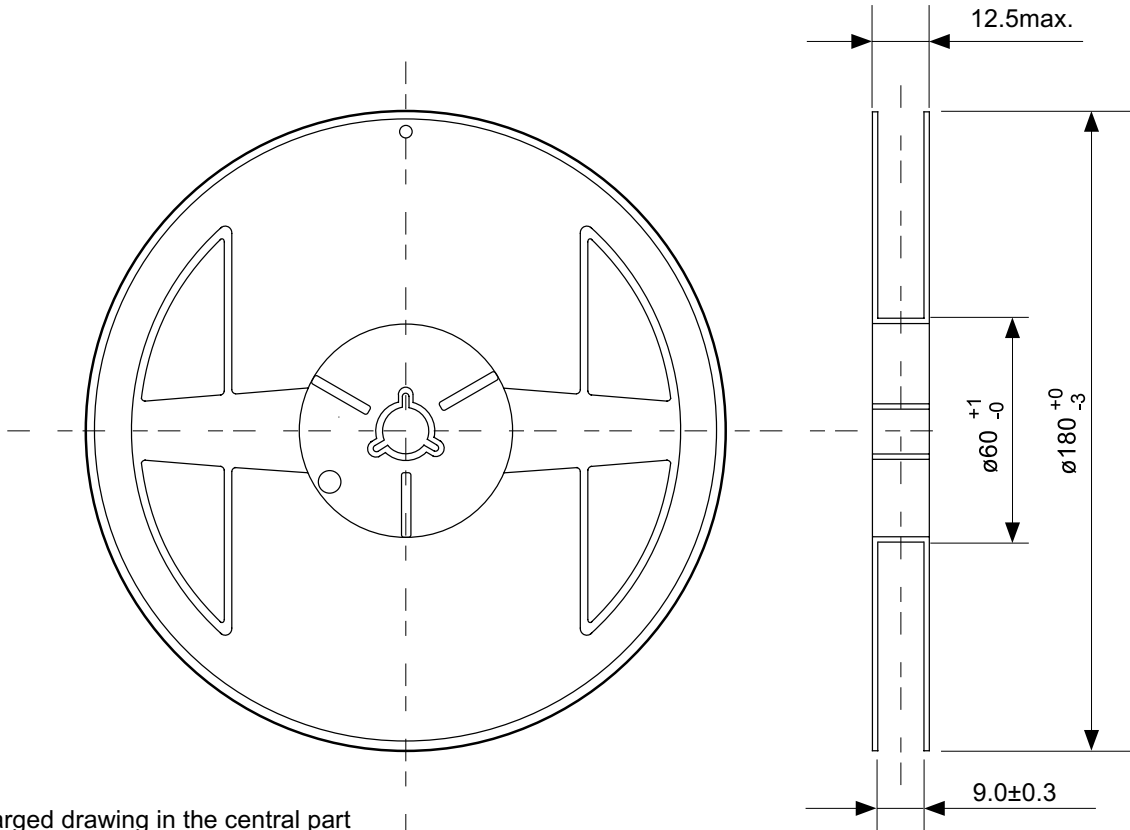

Enlarged drawing in the central part

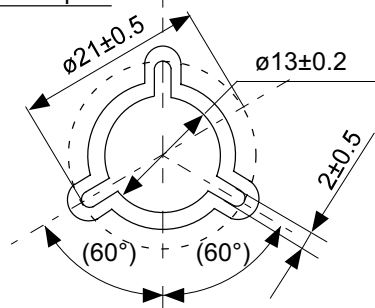

No. PH008-A-R-SD-1.0

TITLE	SNT-8A-A-Reel		
No.	PH008-A-R-SD-1.0		
SCALE		QTY.	5,000
UNIT	mm		
Seiko Instruments Inc.			

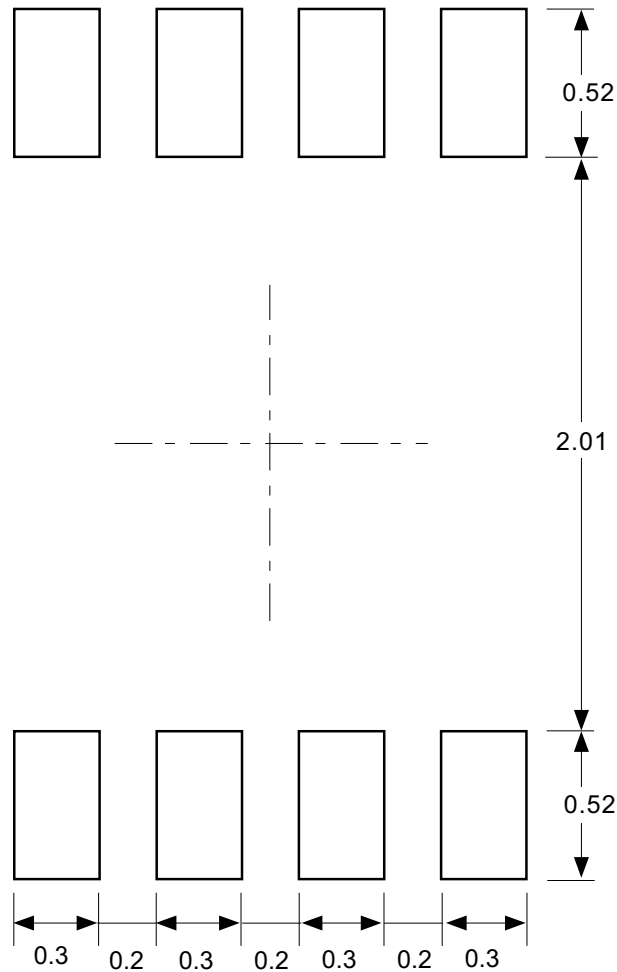

Caution Making the wire pattern under the package is possible. However, note that the package may be upraised due to the thickness made by the silk screen printing and of a solder resist on the pattern because this package does not have the standoff.

注意 パッケージ下への配線パターン形成は可能ですが、本パッケージはスタンドオフが無いので、パターン上のレジスト厚み、シルク印刷の厚みによってパッケージが持ち上がる場合がありますのでご配慮ください。

No. PH008-A-L-SD-3.0

TITLE	SNT-8A-A-Land Recommendation
No.	PH008-A-L-SD-3.0
SCALE	
UNIT	mm
Seiko Instruments Inc.	

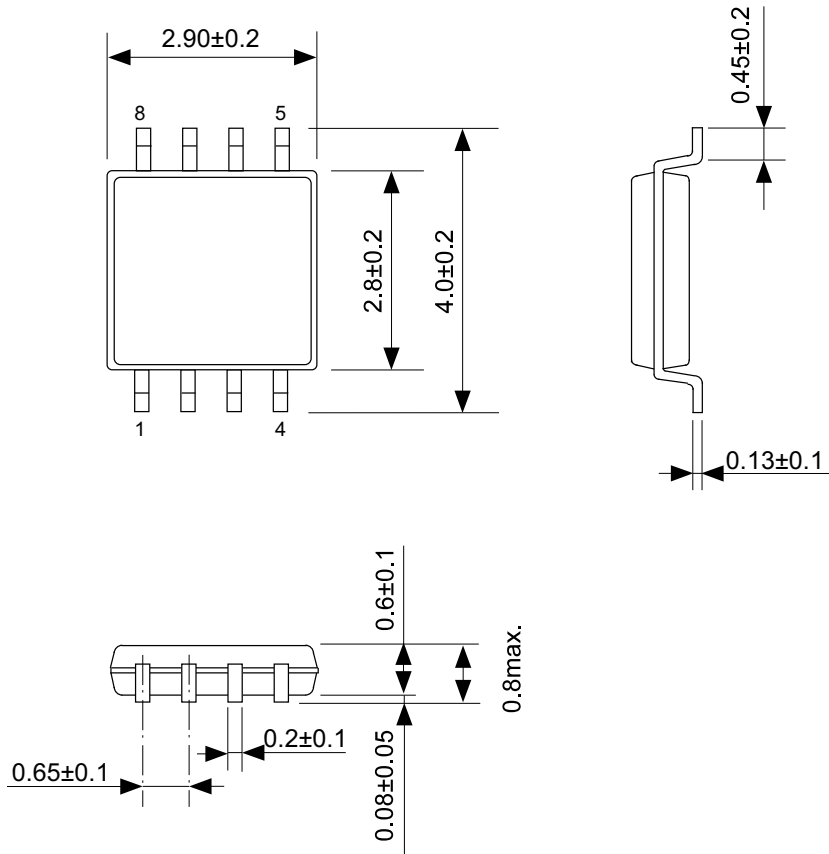

No. FM008-A-P-SD-1.0

TITLE	TMSOP8-A-PKG Dimensions
No.	FM008-A-P-SD-1.0
SCALE	
UNIT	mm
Seiko Instruments Inc.	

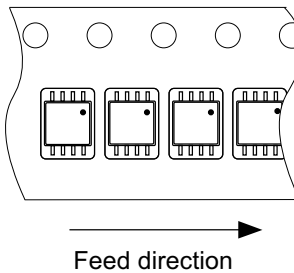
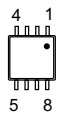
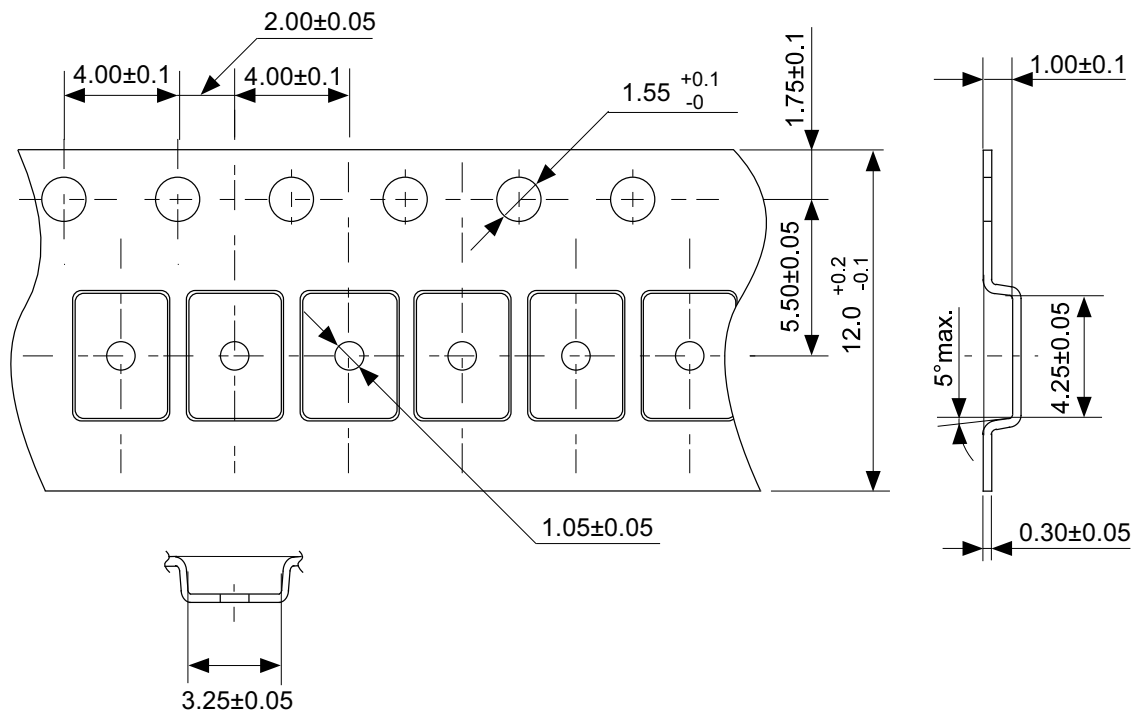

No. FM008-A-C-SD-1.0

TITLE	TMSOP8-A-Carrier Tape
No.	FM008-A-C-SD-1.0
SCALE	
UNIT	mm
Seiko Instruments Inc.	

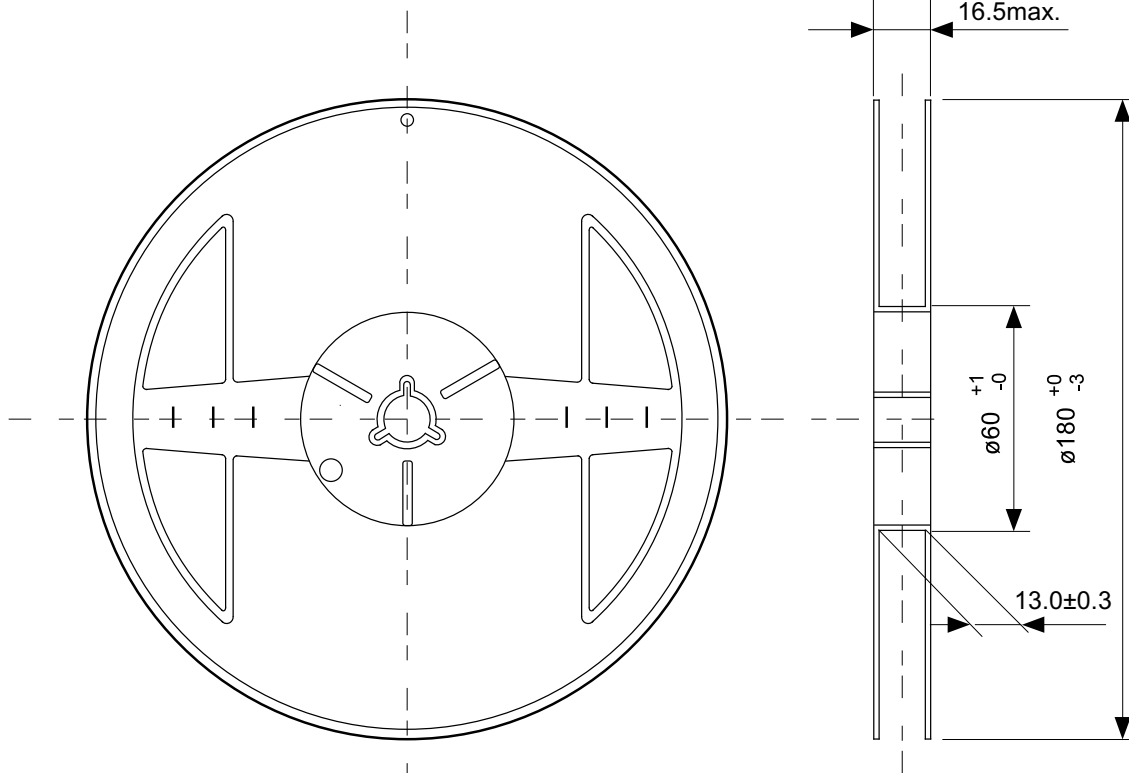

Enlarged drawing in the central part

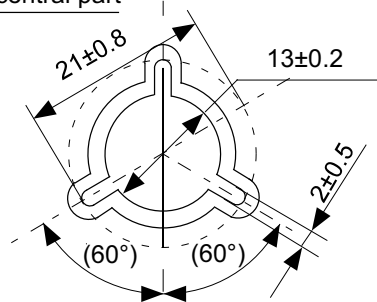

No. FM008-A-R-SD-1.0

TITLE	TMSOP8-A-Reel		
No.	FM008-A-R-SD-1.0		
SCALE		QTY.	4,000
UNIT	mm		
Seiko Instruments Inc.			

- The information described herein is subject to change without notice.
- Seiko Instruments Inc. is not responsible for any problems caused by circuits or diagrams described herein whose related industrial properties, patents, or other rights belong to third parties. The application circuit examples explain typical applications of the products, and do not guarantee the success of any specific mass-production design.
- When the products described herein are regulated products subject to the Wassenaar Arrangement or other agreements, they may not be exported without authorization from the appropriate governmental authority.
- Use of the information described herein for other purposes and/or reproduction or copying without the express permission of Seiko Instruments Inc. is strictly prohibited.
- The products described herein cannot be used as part of any device or equipment affecting the human body, such as exercise equipment, medical equipment, security systems, gas equipment, or any apparatus installed in airplanes and other vehicles, without prior written permission of Seiko Instruments Inc.
- Although Seiko Instruments Inc. exerts the greatest possible effort to ensure high quality and reliability, the failure or malfunction of semiconductor products may occur. The user of these products should therefore give thorough consideration to safety design, including redundancy, fire-prevention measures, and malfunction prevention, to prevent any accidents, fires, or community damage that may ensue.