

FEATURES

- 10 mV sensitivity rail to rail at $V_{CC} = 2.5\text{ V}$
- Input common-mode voltage from -0.2 V to $V_{CC} + 0.2\text{ V}$
- CML-compatible output stage
- 1 ns propagation delay
- 50 mW at 2.5 V
- Shutdown pin (ADCMP607 only)
- Single-pin control for programmable hysteresis and latch (ADCMP607 only)
- Power supply rejection > 60 dB
- -40°C to $+125^{\circ}\text{C}$ operation

APPLICATIONS

- High speed instrumentation
- Clock and data signal restoration
- Logic level shifting or translation
- Pulse spectroscopy
- High speed line receivers
- Threshold detection
- Peak and zero-crossing detectors
- High speed trigger circuitry
- Pulse-width modulators
- Current-/voltage-controlled oscillators
- Automatic test equipment (ATE)

GENERAL DESCRIPTION

The ADCMP606/ADCMP607 are very fast comparators fabricated on Analog Devices' proprietary XFCB2 process. These comparators are exceptionally versatile and easy to use. Features include an input range from $V_{EE} - 0.5\text{ V}$ to $V_{CC} + 0.5\text{ V}$, low noise CML-compatible output drivers, and TTL-/CMOS-compatible latch inputs with adjustable hysteresis and/or shutdown inputs.

The device offers 1 ns propagation delay with 2 ps RMS random jitter (RJ). Overdrive and slew rate dispersion are typically less than 50 ps.

A flexible power supply scheme allows the devices to operate with a single +2.5 V positive supply and a -0.5 V to $+3.0\text{ V}$ input signal range up to a +5.5 V positive supply with a -0.5 V

FUNCTIONAL BLOCK DIAGRAM

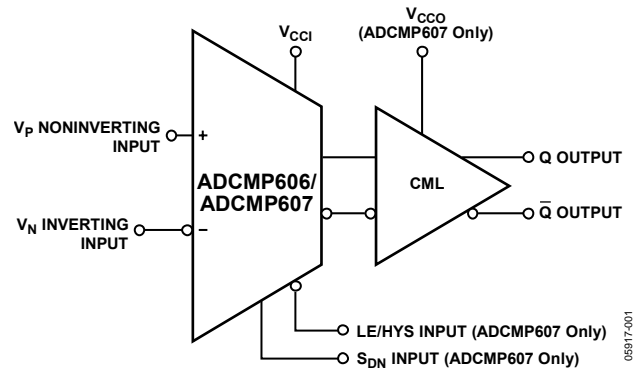

Figure 1.

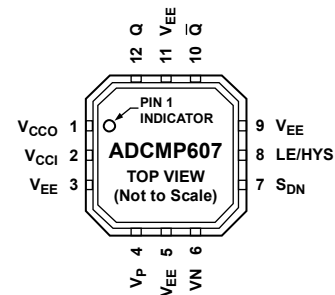

Figure 2.LFCSP Pin Configuration

to +6 V input signal range. The ADCMP607 features split input/output supplies with no sequencing restrictions to support a wide input signal range with independent output level control and power savings.

The CML-compatible output stage is fully back-matched for superior performance. The comparator input stage offers robust protection against large input overdrive, and the outputs do not phase reverse when the valid input signal range is exceeded. On the ADCMP607, high speed latch and programmable hysteresis features are also provided with a unique single-pin control option.

The ADCMP606 is available in a 6-lead SC70 package, and the ADCMP607 is available in a 12-lead LSCFP package.

Rev. PrA

Information furnished by Analog Devices is believed to be accurate and reliable. However, no responsibility is assumed by Analog Devices for its use, nor for any infringements of patents or other rights of third parties that may result from its use. Specifications subject to change without notice. No license is granted by implication or otherwise under any patent or patent rights of Analog Devices. Trademarks and registered trademarks are the property of their respective owners.

TABLE OF CONTENTS

Features	1	Application Information.....	9
Applications.....	1	Power/Ground Layout and Bypassing.....	9
Functional Block Diagram	1	CML-Compatible Output Stage	9
General Description	1	Using/Disabling the Latch Feature.....	9
Revision History	2	Optimizing Performance.....	10
Electrical Characteristics	3	Comparator Propagation Delay Dispersion	10
Absolute Maximum Ratings.....	5	Comparator Hysteresis	10
Thermal Resistance	5	Crossover Bias Point	11
ESD Caution.....	5	Minimum Input Slew Rate Requirement	11
Pin Configuration and Function Descriptions.....	6	Typical Application Circuits	12
Typical Performance Characteristics	7	Timing Information	13

REVISION HISTORY

3/06—Revision PrA: Preliminary Version

ELECTRICAL CHARACTERISTICS

$V_{CCI} = V_{CCO} = 3.0\text{ V}$, $T_A = 25^\circ\text{C}$, unless otherwise noted.

Table 1.

Parameter	Symbol	Conditions	Min	Typ	Max	Unit
DC INPUT CHARACTERISTICS						
Voltage Range	V_P, V_N	$V_{CC} = 2.5\text{ V to } 5.5\text{ V}$	-0.5		$V_{CC} + 0.5\text{ V}$	V
Common-Mode Range		$V_{CC} = 2.5\text{ V to } 5.5\text{ V}$	-0.2		$V_{CC} + 0.2\text{ V}$	V
Differential Voltage		$V_{CC} = 2.5\text{ V to } 5.5\text{ V}$			V_{CC}	V
Offset Voltage	V_{OS}		-5.0		+5.0	mV
Bias Current	I_P, I_N		-5.0	± 2	+5.0	μA
Offset Current			2.0		2.0	μA
Capacitance	C_P, C_N			TBD		pF
Resistance, Differential Mode		0.1 V to V_{CC}		100		k Ω
Resistance, Common Mode		-0.5 V to $V_{CC} + 0.5\text{ V}$		100		k Ω
Active Gain	A_V			54		dB
Common-Mode Rejection	CMRR	$V_{CCI} = 2.5\text{ V}, V_{CCO} = 2.5\text{ V},$ $V_{CM} = -0.2\text{ V to } 2.7\text{ V}$		50		dB
		$V_{CCI} = 5.5\text{ V}, V_{CCO} = 5.5\text{ V},$ $V_{CM} = -0.2\text{ V to } 5.7\text{ V}$		60		dB
Hysteresis		$R_{HYS} = \infty$		0.1		mV
LATCH ENABLE PIN CHARACTERISTICS (ADCMP606 Only)						
V_{IH}		Hysteresis is shut off	2.0		V_{CC}	V
V_{IL}		Latch mode guaranteed	-0.2	+0.4	+0.8	V
I_{IH}		$V_{IH} = V_{CC}$			0.2	mA
I_{OL}		$V_{IL} = 0.4\text{ V}$			-0.2	mA
HYSTERESIS MODE AND TIMING						
Hysteresis Mode Bias Voltage		Current sink 0 μA	1.145	1.25	1.35	V
Minimum Resistor Value		Hysteresis = 16 mV	150			k Ω
Latch Setup Time	t_S	$V_{OD} = 100\text{ mV}$		8		ns
Latch Hold Time	t_H	$V_{OD} = 100\text{ mV}$		5		ns
Latch-to-Output Delay	t_{PLOH}, t_{PLOL}	$V_{OD} = 100\text{ mV}$		1		ns
Latch Minimum Pulse Width	t_{PL}	$V_{OD} = 100\text{ mV}$		1		ns
SHUTDOWN PIN CHARACTERISTICS (ADCMP607 Only)						
V_{IH}		Comparator is operating	2.0		V_{CCO}	V
V_{IL}		Shutdown guaranteed	-0.2	+0.4	+0.6	V
I_{IH}		$V_{IH} = V_{CC}$			0.3	mA
I_{OL}		$V_{IL} = 0\text{ V}$			-0.3	mA
Sleep Time	t_{SD}	$I_{CC} < 500\text{ }\mu\text{A}$		50		ns
Wake-Up Time	t_H	$V_{OD} = 10\text{ mV}$, output valid		80		ns
DC OUTPUT CHARACTERISTICS						
Output Voltage High Level	V_{OH}	$V_{CCO} = 2.5\text{ V to } 5.5\text{ V}$ $R_I = 50\text{ }\Omega, V_{CCO} = 2.5\text{ V}$	$V_{CC} - 0.1$		$V_{CC} + 0.1$	V
Output Voltage Low Level	V_{OL}	$R_I = 50\text{ }\Omega, V_{CCO} = 2.5\text{ V}$	$V_{CC} - 0.35$		$V_{CC} - 0.5$	V
Minimum Output Low Level (ADCMP607)		$V_{CCI} = 2.5\text{ V}, T_A = -40^\circ\text{C}$ (internal termination only)		TBD		

Parameter	Symbol	Conditions	Min	Typ	Max	Unit
AC PERFORMANCE						
Propagation Delay	t_{PD}	$V_{CC} = 2.5\text{ V to } 5.5\text{ V}$, $V_{OD} = 5\text{ mV}$		1		ns
		$V_{CC} = 2.5\text{ V to } 5.5\text{ V}$, $V_{OD} = 200\text{ mV}$		1		ns
Propagation Delay Skew—Rising to Falling Transition		$V_{OD} = 5\text{ mV}$		40		ps
Overdrive Dispersion		$10\text{ mV} < V_{OD} < 2.5\text{ V}$		TBD		ps
		$5\text{ mV} < V_{OD} < 2.5\text{ V}$		TBD		ps
Slew Rate Dispersion		$0.05\text{ V/ns to } 2.5\text{ V/ns}$		TBD		ps
Pulse-Width Dispersion		$300\text{ ps to } 20\text{ ns}$		TBD		ps
10% to 90% Duty Cycle Dispersion		$1\text{ V/ns, } V_{CM} = 2.5\text{ V}$		TBD		ps
Common-Mode Dispersion		$0 < V_{CM} < V_{CC}$		TBD		ps
Toggle Rate		$>50\%$ output swing		TBD		Gbps
Deterministic Jitter CML Outputs	DJ	$V_{OD} = 200\text{ mV, } 5\text{ V/ns}$, PRBS ³¹ – 1 NRZ, 0.25 Gbps		TBD		ps
RMS Random Jitter	RJ	$V_{OD} = 200\text{ mV, } 5\text{ V/ns}$, PRBS ³¹ – 1 NRZ, 0.525 Gbps		TBD		ps
Minimum Pulse Width	PW_{MIN}	$\Delta t_{PD}/\Delta PW < 50\text{ ps}$		300		ps
Rise Time	t_R	10% to 90%		150		ps
Fall Time	t_F	10% to 90%		150		ps
Output skew	t_{SKEW}	50%		20		ps
POWER SUPPLY						
Input Supply Voltage Range	V_{CCI}		2.5		5.5	V
Output Supply Voltage Range	V_{CCO}		2.5		5.5	V
Positive Supply Differential (ADCMP607)	$V_{CCI} - V_{CCO}$	Operating	-3.0		+3.0	V
Positive Supply Differential (ADCMP607)	$V_{CCI} - V_{CCO}$	Nonoperating	-5.5		+5.5	V
Positive Supply Current	I_{VCC}	$V_{CC} = 2.5\text{ V}$		23		mA
Positive Supply Current	I_{VCC}	$V_{CC} = 5.5\text{ V}$		25		mA
Input Section Supply Current (ADCMP607)	I_{VCCI}	$V_{CCI} = 2.5\text{ V to } 5\text{ V}$		0.8		mA
Output Section Supply Current (ADCMP607)	I_{VCCO}	$V_{CCI} = 2.5\text{ V to } 5.5\text{ V}$		22.5		mA
Power Dissipation	P_D	$V_{CC} = 2.5\text{ V}$		57		mW
	P_D	$V_{CC} = 5.5\text{ V}$		125		mW
Power Supply Rejection	PSRR	$V_{CCI} = 2.5\text{ V to } 5\text{ V}$		-50		dB

ABSOLUTE MAXIMUM RATINGS

Table 2.

Parameter	Rating
Supply Voltages	
Input Supply Voltage (V_{CC1} to GND)	-0.5 V to +6.0 V
Output Supply Voltage (V_{CC0} to GND)	-0.5 V to +6.0 V
Positive Supply Differential ($V_{CC1} - V_{CC0}$)	-6.0 V to +6.0 V
Input Voltages	
Input Voltage	-0.5 V to $V_{CC1} + 0.5$ V
Differential Input Voltage	$\pm(V_{CC1} + 0.5$ V)
Maximum Input/Output Current	± 50 mA
Shutdown Control Pin	
Applied Voltage (HYS to GND)	-0.5 V to $V_{CC0} + 0.5$ V
Maximum Input/Output Current	± 50 mA
Latch/Hysteresis Control Pin	
Applied Voltage (HYS to GND)	-0.5 V to $V_{CC0} + 0.5$ V
Maximum Input/Output Current	± 50 mA
Output Current	± 50 mA
Temperature	
Operating Temperature, Ambient	-40°C to +125°C
Operating Temperature, Junction	150°C
Storage Temperature Range	-65°C to +150°C

Stresses above those listed under Absolute Maximum Ratings may cause permanent damage to the device. This is a stress rating only; functional operation of the device at these or any other conditions above those indicated in the operational section of this specification is not implied. Exposure to absolute maximum rating conditions for extended periods may affect device reliability.

THERMAL RESISTANCE

J_A is specified for the worst-case conditions, that is, a device soldered in a circuit board for surface-mount packages.

Table 3. Thermal Resistance

Package Type	θ_{JA}^1	Unit
ADCMP606 SC70 6-lead	426	°C/W
ADCMP607 LSCFP 12-lead	62	°C/W

¹ Measurement in still air.

ESD CAUTION

ESD (electrostatic discharge) sensitive device. Electrostatic charges as high as 4000 V readily accumulate on the human body and test equipment and can discharge without detection. Although this product features proprietary ESD protection circuitry, permanent damage may occur on devices subjected to high energy electrostatic discharges. Therefore, proper ESD precautions are recommended to avoid performance degradation or loss of functionality.



PIN CONFIGURATION AND FUNCTION DESCRIPTIONS

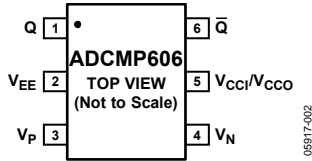

Figure 3. ADCMP606 Pin Configuration

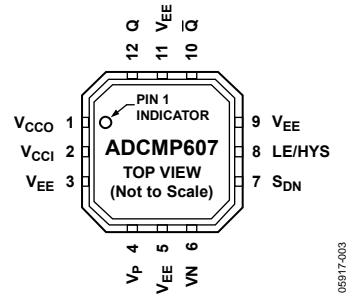

Figure 4. ADCMP607 Pin Configuration

Table 4. ADCMP606 (SC70-6) Pin Function Descriptions

Pin No.	Mnemonic	Description
1	Q	Noninverting Output. Q is at logic high if the analog voltage at the noninverting input, V_P , is greater than the analog voltage at the inverting input, V_N .
2	V_{EE}	Negative Supply Voltage.
3	V_P	Noninverting Analog Input.
4	V_N	Inverting Analog Input.
5	V_{CC1}/V_{CCO}	Input Section Supply/Output Section Supply. Shared pin.
6	\overline{Q}	Inverting Output. \overline{Q} is at logic low if the analog voltage at the noninverting input, V_P , is greater than the analog voltage at the inverting input, V_N .

Table 5. ADCMP607 (LSCFP-12) Pin Function Descriptions

Pin No.	Mnemonic	Description
1	V_{CCO}	Output Section Supply.
2	V_{CC1}	Input Section Supply.
3	V_{EE}	Negative Supply Voltage.
4	V_P	Noninverting Analog Input.
5	V_{EE}	Negative Supply Voltage.
6	V_N	Inverting Analog Input.
7	S_{DN}	Shutdown. Drive this pin low to shut down the device.
8	LE/HYS	Latch/Hysteresis Control. Bias with resistor or current for hysteresis adjustment; drive low to latch.
9	V_{EE}	Negative Supply Voltage.
10	\overline{Q}	Inverting Output. \overline{Q} is at logic low if the analog voltage at the noninverting input, V_P , is greater than the analog voltage at the inverting input, V_N , provided that the comparator is in compare mode.
11	V_{EE}	Negative Supply Voltage.
12	Q	Noninverting Output. Q is at logic high if the analog voltage at the noninverting input, V_P , is greater than the analog voltage at the inverting input, V_N , provided that the comparator is in compare mode.
Heat Sink Paddle	V_{EE}	The metallic back surface of the package is electrically connected to V_{EE} . It can be left floating because Pin 3, Pin 5, Pin 9, and Pin 11 provide adequate electrical connection. It can also be soldered to the application board if improved thermal and/or mechanical stability is desired.

TYPICAL PERFORMANCE CHARACTERISTICS

$V_{CC1} = V_{CC0} = 3.3\text{ V}$, $T_A = 25^\circ\text{C}$, unless otherwise noted.

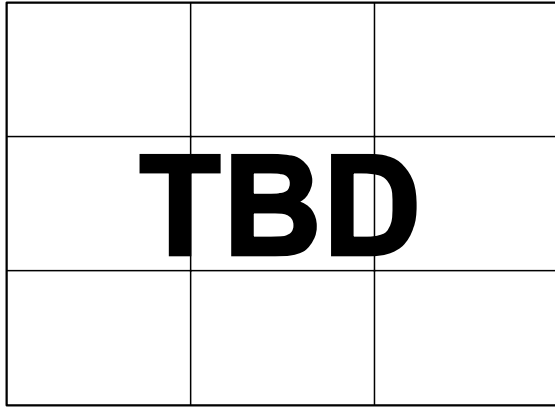

Figure 5. Propagation Delay vs. Input Overdrive

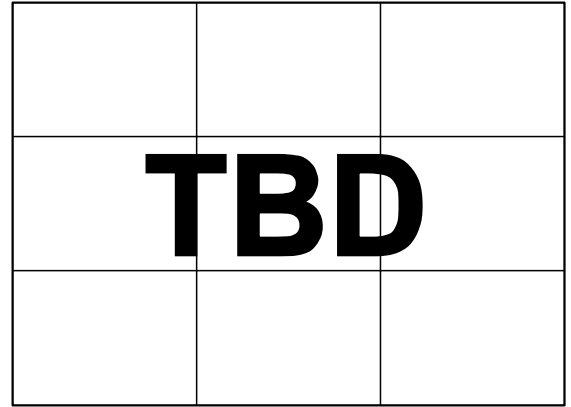

Figure 8. Rise/Fall Time vs. Temperature

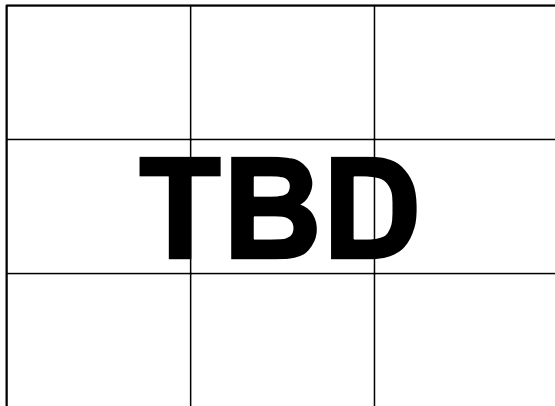

Figure 6. Propagation Delay vs. Input Common Mode

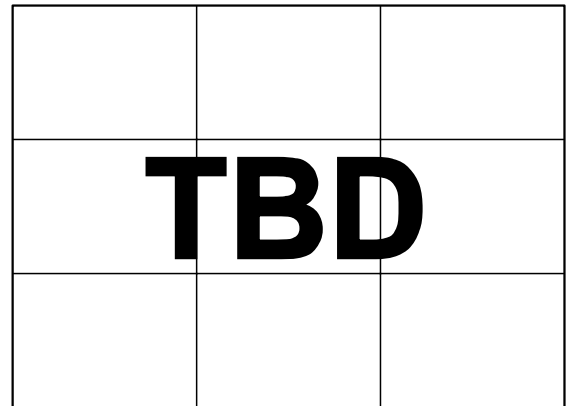

Figure 9.

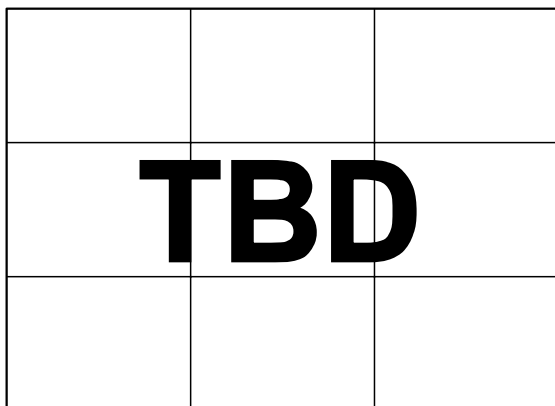

Figure 7. Propagation Delay vs. Temperature

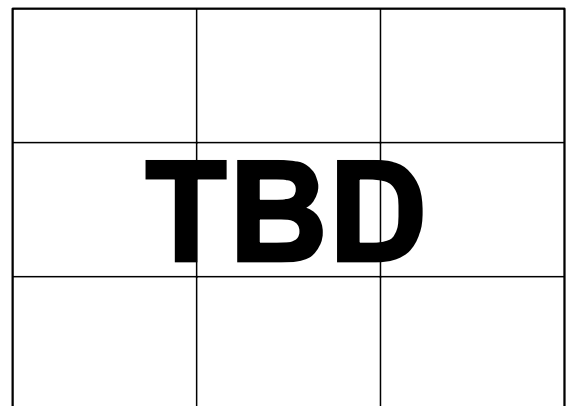

Figure 10. Input Bias Current vs. Input Common Mode

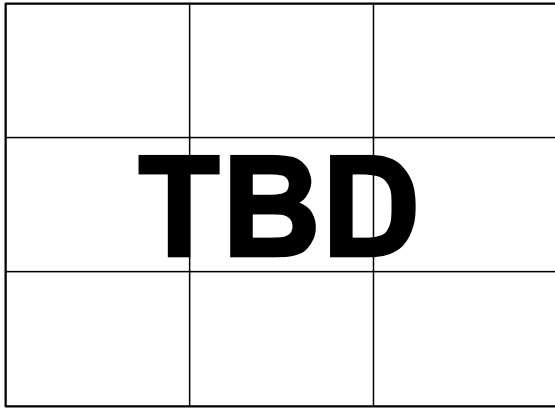

Figure 11. Input Bias Current vs. Temperature

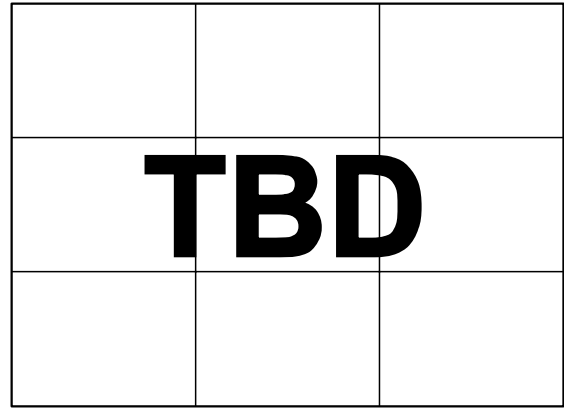

Figure 13. Input Offset Voltage vs. Temperature

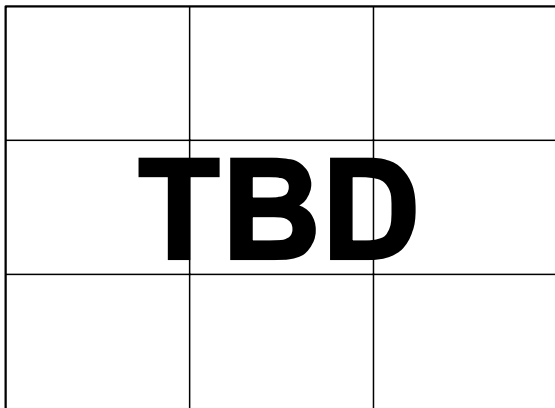

Figure 12. Hysteresis vs. V_{CC}

APPLICATION INFORMATION

POWER/GROUND LAYOUT AND BYPASSING

The ADCMP606 and ADCMP607 comparators are very high speed devices. Despite the low noise output stage, it is essential to use proper high speed design techniques to achieve the specified performance. Because comparators are uncompensated amplifiers, feedback in any phase relationship is likely to cause oscillations or undesired hysteresis. Of critical importance is the use of low impedance supply planes, particularly the output supply plane (V_{CCO}) and the ground plane (GND). Individual supply planes are recommended as part of a multilayer board. Providing the lowest inductance return path for switching currents ensures the best possible performance in the target application.

It is also important to adequately bypass the input and output supplies. Multiple high quality 0.01 μF bypass capacitors should be placed as close as possible to each of the V_{CCI} and V_{CCO} supply pins and should be connected to the GND plane with redundant vias. At least one of these should be placed to provide a physically short return path for output currents flowing back from ground to the V_{CC} pin. High frequency bypass capacitors should be carefully selected for minimum inductance and ESR. Parasitic layout inductance should also be strictly controlled to maximize the effectiveness of the bypass at high frequencies.

CML-COMPATIBLE OUTPUT STAGE

Specified propagation delay dispersion performance can be achieved by using proper transmission line terminations. The outputs of the ADCMP606 and ADCMP607 are designed to drive 400 mV directly into a 50 Ω cable or into transmission lines terminated using either microstrip or strip line techniques with 50 Ω referenced to V_{CC} . The CML output stage is shown in the simplified schematic diagram in Figure 14. Each output is back-terminated with 50 Ω for best transmission line matching.

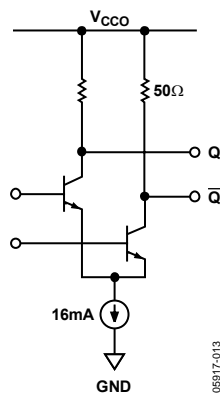

Figure 14. Simplified Schematic Diagram of CML-Compatible Output Stage

If these high speed signals must be routed more than a centimeter, then either microstrip or strip line techniques are required to ensure proper transition times and to prevent excessive output ringing and pulse-width-dependent propagation delay dispersion.

It is also possible to operate the outputs with only the internal termination if greater output swing is desired. This can be especially useful for driving inputs on CMOS devices intended for full swing ECL and PECL. V_{CCO} must be kept high enough that the specified minimum output low level (see the Electrical Characteristics section) is not violated and the line length driven is as short as possible.

USING/DISABLING THE LATCH FEATURE

The latch input of the ADCMP607 is designed for maximum versatility. It can safely be left floating, or it can be driven low by any standard TTL/CMOS device as a high speed latch.

In addition, the pin can be operated as a hysteresis control pin with a bias voltage of 1.25 V nominal and an input resistance of approximately 7000 Ω , allowing the comparator hysteresis to be easily controlled by either a resistor or an inexpensive CMOS DAC. Driving this pin high or floating the pin removes all hysteresis.

Hysteresis control and latch mode can be used together if an open drain, an open collector, or a three-state driver is connected parallel to the hysteresis control resistor or current source.

Due to the programmable hysteresis feature, the logic threshold of the latch pin is approximately 1.1 V regardless of V_{CC} .

OPTIMIZING PERFORMANCE

As with any high speed comparator, proper design and layout techniques are essential for obtaining the specified performance. Stray capacitance, inductance, inductive power and ground impedances, or other layout issues can severely limit performance and often cause oscillation. Large discontinuities along input and output transmission lines can also limit the specified pulse-width dispersion performance. The source impedance should be minimized as much as is practicable. High source impedance, in combination with the parasitic input capacitance of the comparator, causes an undesirable degradation in bandwidth at the input, thus degrading the overall response. Thermal noise from large resistances can easily cause extra jitter with slowly slewing input signals; higher impedances encourage undesired coupling.

COMPARATOR PROPAGATION DELAY DISPERSION

The ADCMP606/ADCMP607 comparators are designed to reduce propagation delay dispersion over a wide input overdrive range of 5 mV to $V_{CCI} - 1$ V. Propagation delay dispersion is the variation in propagation delay that results from a change in the degree of overdrive or slew rate (that is, how far or how fast the input signal exceeds the switching threshold).

Propagation delay dispersion is a specification that becomes important in high speed, time-critical applications, such as data communication, automatic test and measurement, and instrumentation. It is also important in event-driven applications, such as pulse spectroscopy, nuclear instrumentation, and medical imaging. Dispersion is defined as the variation in propagation delay as the input overdrive conditions are changed (Figure 15 and Figure 16).

ADCMP606/ADCMP607 dispersion is typically <TBD ps as the overdrive varies from 10 mV to 500 mV and the input slew rate varies from 2 V/ns to 10 V/ns. This specification applies to both positive and negative signals because each device has very closely matched delays for positive-going and negative-going inputs, as well as very low output skews.

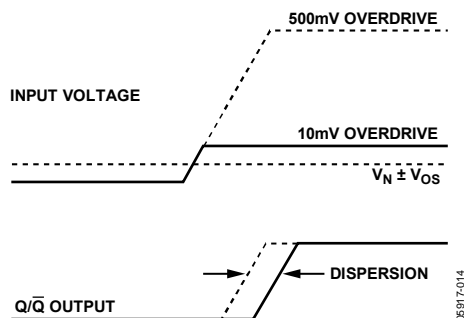

Figure 15. Propagation Delay—Overdrive Dispersion

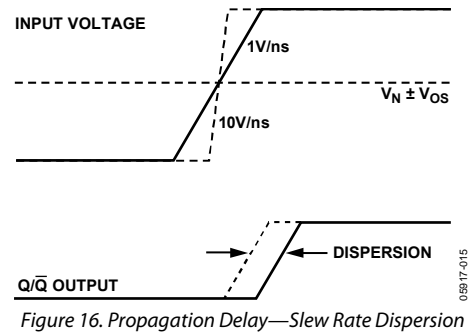

Figure 16. Propagation Delay—Slew Rate Dispersion

COMPARATOR HYSTERESIS

The addition of hysteresis to a comparator is often desirable in a noisy environment, or when the differential input amplitudes are relatively small or slow moving. Figure 17 shows the transfer function for a comparator with hysteresis. As the input voltage approaches the threshold (0.0 V, in this example) from below the threshold region in a positive direction, the comparator switches from low to high when the input crosses $+V_H/2$, and the new switching threshold becomes $-V_H/2$. The comparator remains in the high state until the new threshold, $-V_H/2$, is crossed from below the threshold region in a negative direction. In this manner, noise or feedback output signals centered on 0.0 V input cannot cause the comparator to switch states unless it exceeds the region bounded by $\pm V_H/2$.

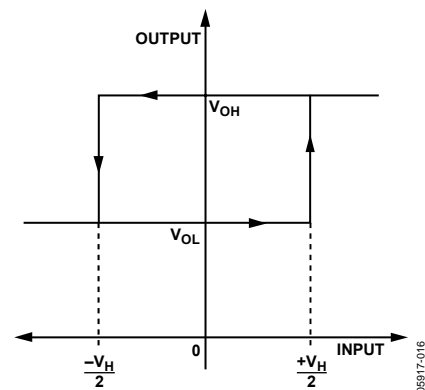

Figure 17. Comparator Hysteresis Transfer Function

The customary technique for introducing hysteresis into a comparator uses positive feedback from the output back to the input. One limitation of this approach is that the amount of hysteresis varies with the output logic levels, resulting in hysteresis that is not symmetric about the threshold. The external feedback network can also introduce significant parasitics that reduce high speed performance and induce oscillation in some cases.

The ADCMP607 comparator offers a programmable hysteresis feature that can significantly improve accuracy and stability. Connecting an external pull-down resistor or a current source from the LE/HYS pin to GND, varies the amount of hysteresis in a predictable, stable manner. Leaving the LE/HYS pin disconnected or driving it high removes the hysteresis. The

maximum hysteresis that can be applied using this pin is approximately 160 mV. Figure 18 illustrates the amount of hysteresis applied as a function of the external resistor value, and Figure TBD illustrates hysteresis as a function of the current.

The hysteresis control pin appears as a 1.25 V bias voltage seen through a series resistance of $7k \pm 20\%$ throughout the hysteresis control range. The advantages of applying hysteresis in this manner are improved accuracy, improved stability, reduced component count, and maximum versatility. An external bypass capacitor is not recommended on the HYS pin because it impairs the latch function and often degrades the jitter performance of the device. As described in the Using/Disabling the Latch Feature section, hysteresis control need not compromise the latch function.

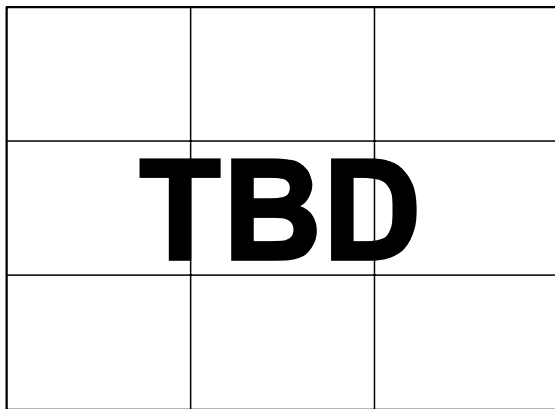

Figure 18. Hysteresis vs. R_{HYS} Control Resistor

CROSSOVER BIAS POINT

In both op amps and comparators, rail-to-rail inputs of this type have a dual front-end design. Certain devices are active near the V_{CC} rail and others are active near the V_{EE} rail. At some predetermined point in the common-mode range, a crossover occurs. At this point, normally $V_{CC}/2$, the direction of the bias current reverses and the measured offset voltages and currents change.

The ADCMP606/ADCMP607 slightly elaborate on this scheme. With V_{CC} less than 4 V, this crossover is at the expected $V_{CC}/2$, but with V_{CC} greater than 4 V, the crossover point instead follows V_{CC} 1:1, bringing it to approximately 3 V with V_{CC} at 5 V. This means that at any voltage, the comparator input characteristics more closely resemble the inputs of nonrail-to-rail ground sensing comparators, such as the AD8611.

MINIMUM INPUT SLEW RATE REQUIREMENT

(Remove if device is stable.)

As with most high speed comparators without hysteresis, a minimum slew rate must be met to ensure that the device does not oscillate as the input signal crosses the threshold. This oscillation is due in part to the high input bandwidth of the comparator in combination with feedback parasitics inherent in the package and PC board. A minimum slew rate of TBD V/ μ s ensures clean output transitions from the ADCMP606/ADCMP607 comparators unless hysteresis is programmed. In many applications, chattering due to the absence of hysteresis is not harmful.

TYPICAL APPLICATION CIRCUITS

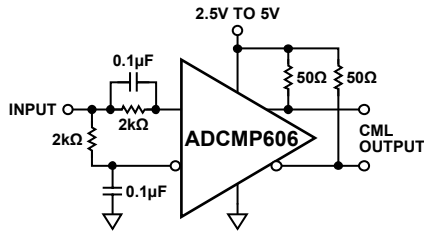

Figure 19. Self-Biased, 50% Slicer

05917-018

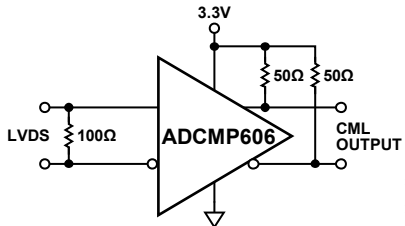

Figure 20. LVDS to CML

05917-019

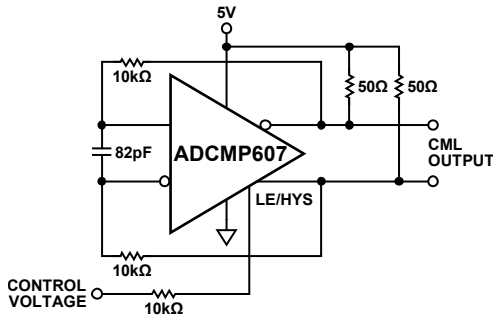

Figure 21. Current-Controlled Oscillator

05917-020

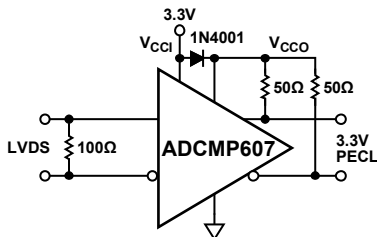

Figure 22. Fake PECL Levels Using a Series Diode

05917-021

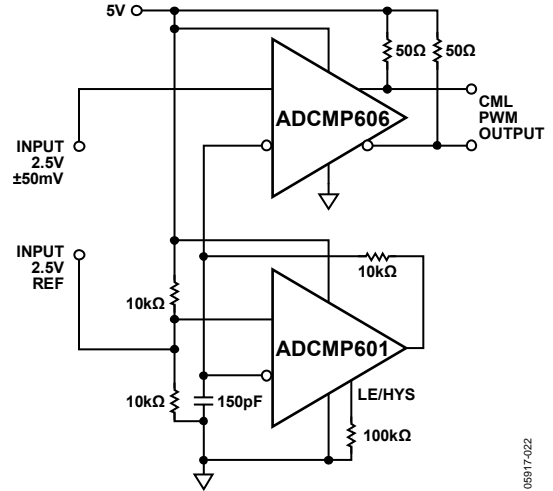

Figure 23. Oscillator and Pulse-Width Modulator

05917-022

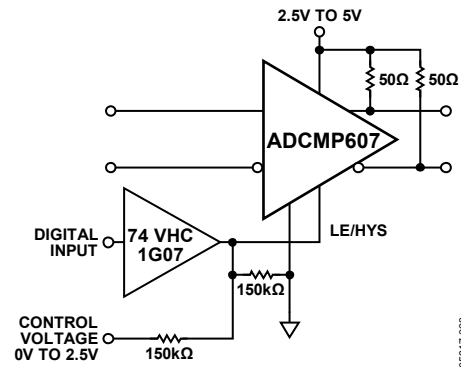

Figure 24. Hysteresis Adjustment with Latch

05917-023

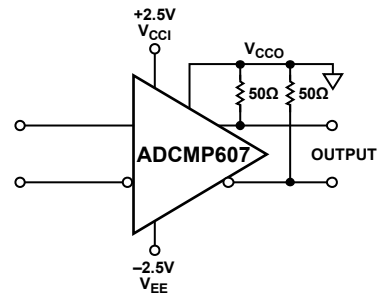

Figure 25. Ground-Referenced CML with ± 3 V Input Range

05917-024

TIMING INFORMATION

Figure 26 illustrates the ADCMP606/ADCMP607 timing relationships. Table 6 provides definitions of the terms shown in the figure.

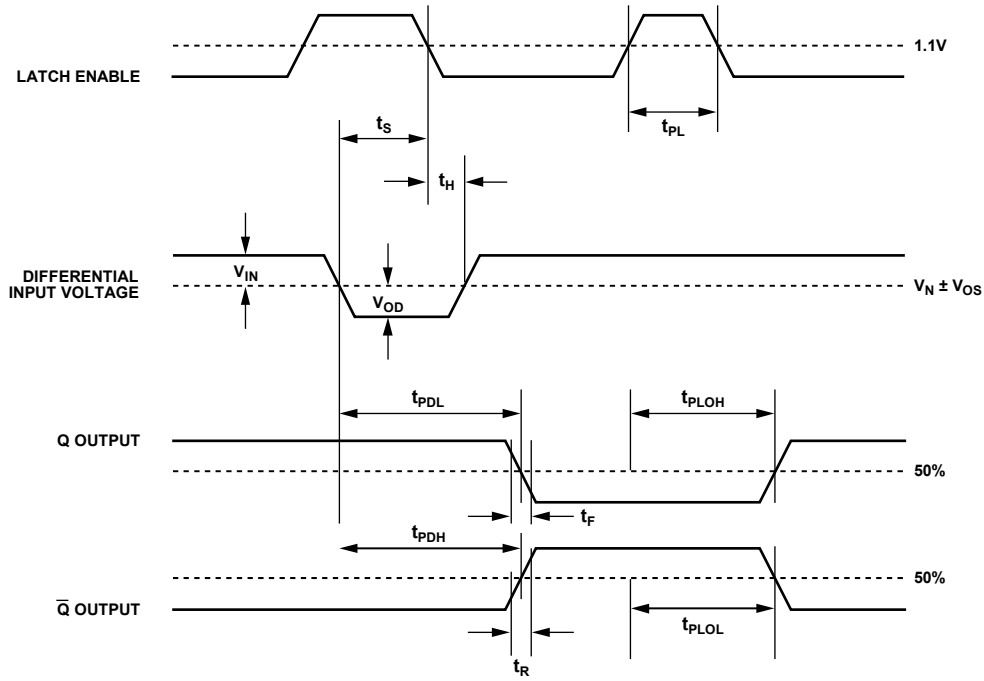

Figure 26. System Timing Diagram

05917-025

Table 6. Timing Descriptions

Symbol	Timing	Description
t_{PDH}	Input to output high delay	Propagation delay measured from the time the input signal crosses the reference (\pm the input offset voltage) to the 50% point of an output low-to-high transition.
t_{PDL}	Input to output low delay	Propagation delay measured from the time the input signal crosses the reference (\pm the input offset voltage) to the 50% point of an output high-to-low transition.
t_R	Output rise time	Amount of time required to transition from a low to a high output as measured at the 20% and 80% points.
t_F	Output fall time	Amount of time required to transition from a high to a low output as measured at the 20% and 80% points.
V_{OD}	Voltage overdrive	Difference between the input voltages V_A and V_B .

NOTES

NOTES

NOTES