

M62413FP

ELECTRONIC SOUND CONTROL WITH ELECTRONIC VOLUME FOR MULTIPLE SOURCES

DESCRIPTION

The M62413FP Integrated Circuit is developed for audio-visual equipment.

It being used for controls sound in the power amplifier front stage.

This IC having are 2 channel input selector with 4 inputs, master volume control [by the VCA (voltage controlled amplifier) system], tone controls (bass, mid, treble) and super bass that IC can be operated by using serial data from microcomputer.

This IC can be applied to not only audio systems but also TV.

FEATURES

- Built-in electronic volume circuit for main volume control
- Volume variation range..... - 96dB to + 9dB
- With built-in bus boost circuit, bass can be intensified
- Sound control
 - Treble..... - 10dB to + 16dB(2dB/step)
 - Mid..... - 10dB to + 10dB(2dB/step)
 - Bass..... - 10dB to + 16dB(2dB/step)
 - Super bass... - 12dB to + 12dB(2dB and 3dB/step)
- Volume is controlled by 8-bit serial data from micro-computer
 - Treble, mid, bass and super bass are controlled each by 4-bit serial data
- Built-in microcomputer interface circuit
- Built-in selector circuit (4 inputs)
- Built-in output ports (9 lines)

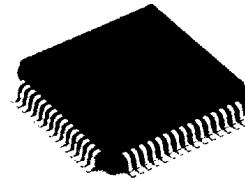

Outline 64P6N-A
0.8mm pitch QFP
(14.0mm × 14.0mm × 2.8mm)

RECOMMENDED OPERATING CONDITIONS

- Supply voltage range.....Vcc = 7.5 to 12V
- Rated supply voltage.....Vcc = 9V

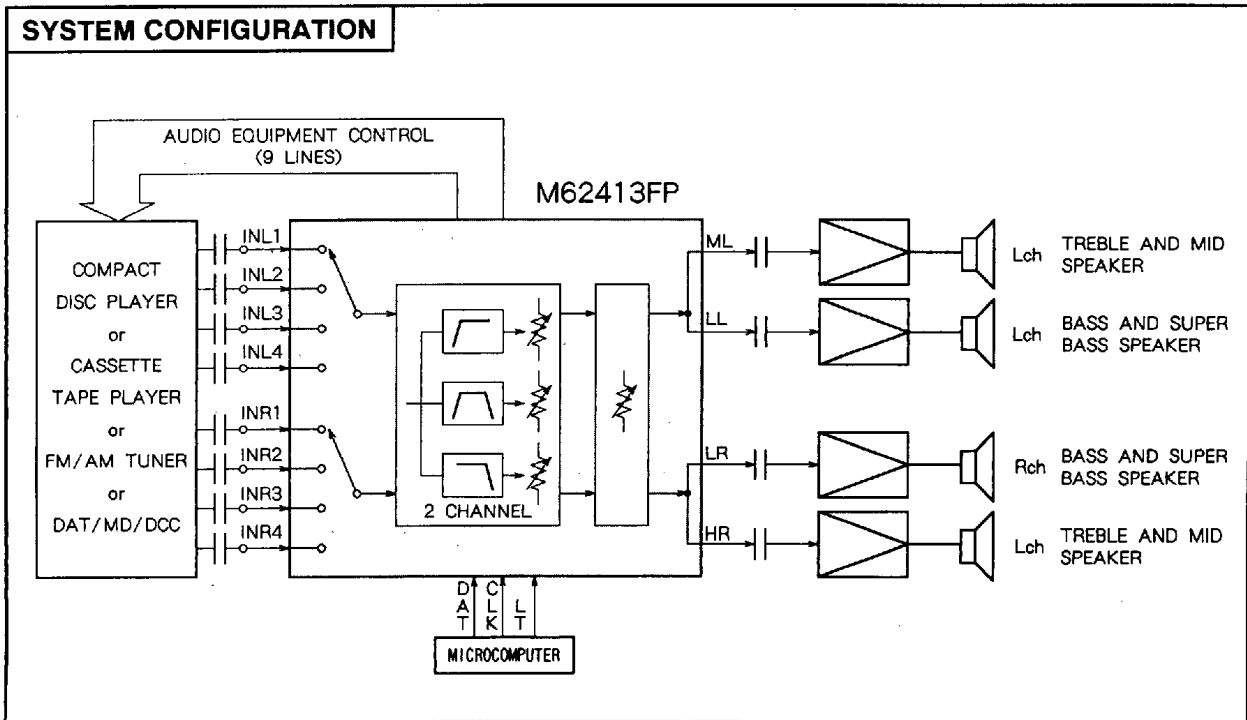

■ 6249826 0022195 T88 ■



ELECTRONIC SOUND CONTROL WITH ELECTRONIC VOLUME FOR MULTIPLE SOURCES

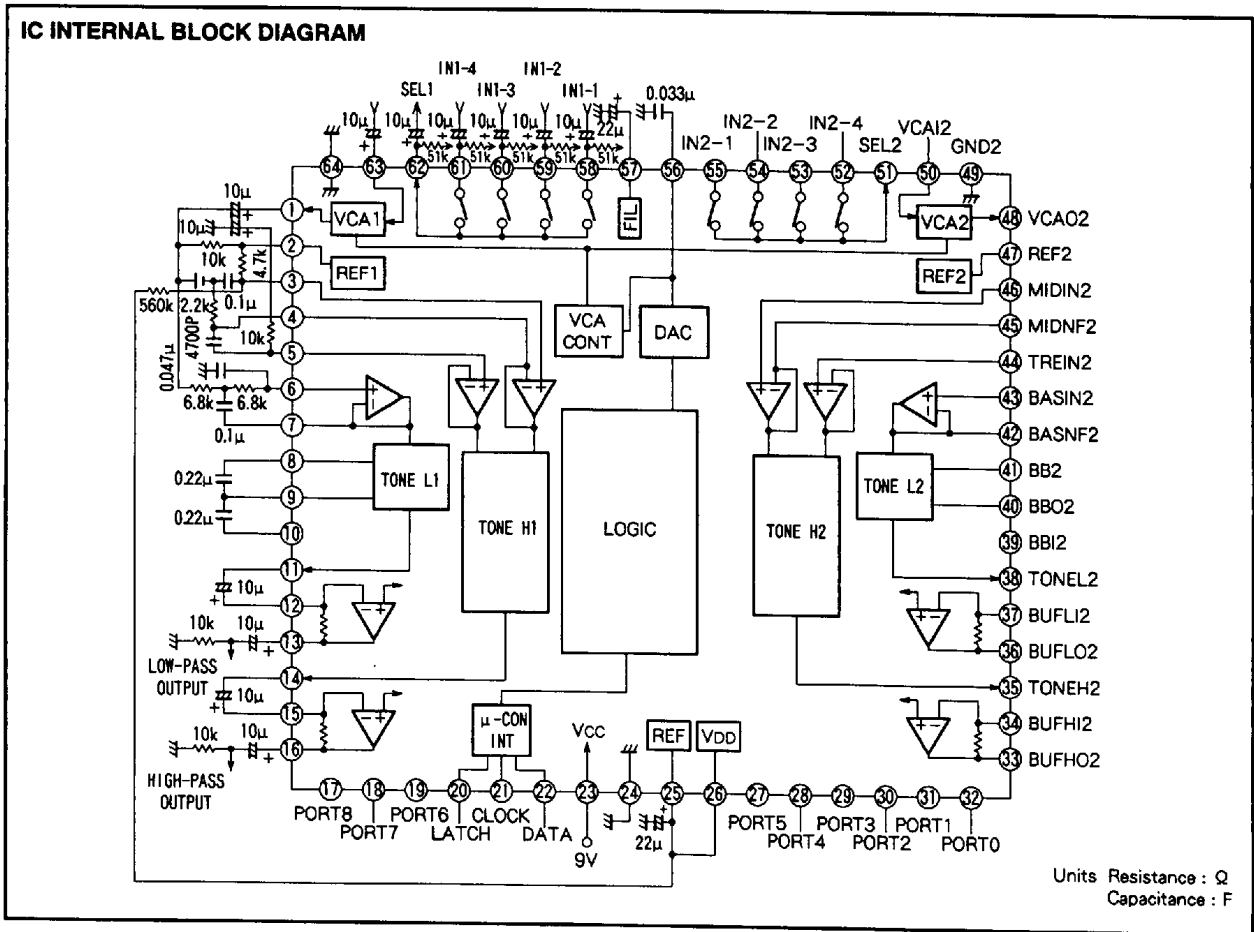
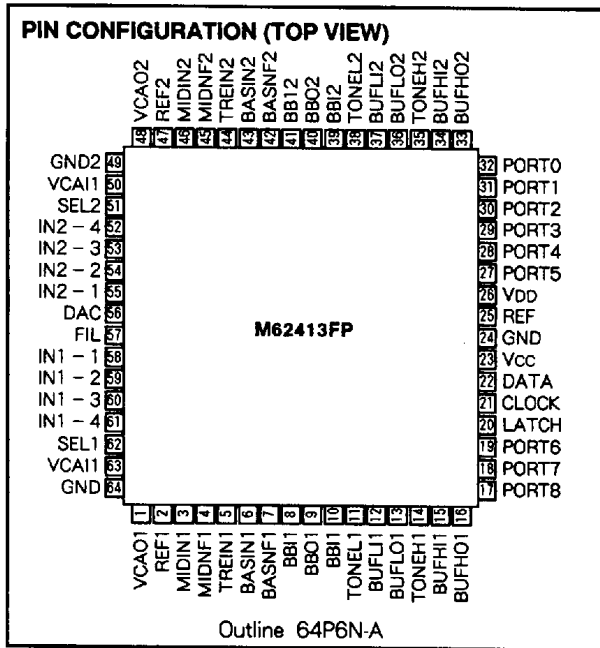

6249826 0022196 914



ELECTRONIC SOUND CONTROL WITH ELECTRONIC VOLUME FOR MULTIPLE SOURCES

PIN DESCRIPTION

Pin No.	Symbol	DC voltage(V)	I/O	Equivalent circuit
① ⑫	VCAO1 VCAO2	3.5	O	
② ⑭	REF1 REF2	3.5	O	
⑤ ⑬	TREIN1 TREIN2	-	I	
③ ⑮ ⑥ ⑩	MIDIN1 MIDIN2 BISIN1 BISIN2	-	I	
④ ⑱ ⑦ ⑲	MIDNF1 MIDNF2 BASNF1 BASNF2	-	I	
⑧ ⑪	BBI1 BBI2	1.75	-	
⑩ ⑳	TONEL1 TONEL2	1.75	O	
⑨ ⑬	BBO1 BBO2	2.3	O	
⑩ ㉑	BBI1 BBI2	3.0	I	

6249826 0022197 850



ELECTRONIC SOUND CONTROL WITH ELECTRONIC VOLUME FOR MULTIPLE SOURCES

PIN DESCRIPTION (Continued)

Pin No.	Symbol	DC voltage(V)	I/O	Equivalent circuit
12 37	BUFLI1 BUFLI2	3.5	I	
13 36	BUFL01 BUFL02	3.5	O	
14 35	TONEH1 TONEH2	1.75	O	
15 34	BUFHI1 BUFHI2	3.5	I	
16 33	BUFHO1 BUFHO2	3.5	O	
17 32	PORT8 PORT0	H : 4.4 L : 0	O	
18 19 27 28 29 30 31	PORT7 PORT6 PORT5 PORT4 PORT3 PORT2 PORT1	-	O	
20 21 22	LATCH CLOCK DATA	-	I	

6249826 0022198 797



ELECTRONIC SOUND CONTROL WITH ELECTRONIC VOLUME FOR MULTIPLE SOURCES

PIN DESCRIPTION (Continued)

Pin No.	Symbol	DC voltage(V)	I/O	Equivalent circuit
23	Vcc	9	-	
24	GND	0	-	
25	REF	5.8	0	
26	Vdd	-	I	
49	GND	0	-	
64	GND	0	-	
50	VCAI2	3.9	I	
63	VCAI1			
51	SEL1	-	0	
62	SEL2			
52	IN2 - 1	-	I	
53	IN1 - 1			
54	IN2 - 2			
55	IN1 - 2			
56	IN2 - 3			
57	IN1 - 3			
58	IN2 - 4			
59	IN1 - 4			
60				
61				
56	DAC	0~5.8	0	
57	FIL	8.9	I	

6249826 0022199 623



ELECTRONIC SOUND CONTROL WITH ELECTRONIC VOLUME FOR MULTIPLE SOURCES

ABSOLUTE MAXIMUM RATINGS (Ta = 25°C, unless otherwise noted)

Symbol	Parameter	Ratings	Unit
Vcc	Supply voltage	14	V
Vi	Digital input voltage	- 0.3 to 7.0	V
Pa	Power dissipation	1000*Standard circuit board	mW
Kθ	Thermal derating	10	mW/°C
Topr	Operating temperature	- 10 to + 70	°C
Tstg	Storage temperature	- 40 to + 125	°C

ELECTRICAL CHARACTERISTICS

(Ta = 25°C, Vcc = 9V, control data (volume maximum/tone flat) and f = 1kHz unless otherwise noted)

Block name	Symbol	Parameter	Test conditions										Limits			Unit	
			Input condition	Number of data	SW conditions								Test point	Min	Typ		Max
					SA 1	SA 2	SB 1	SB 2	SC 1	SC 2	SD						
Power supply	Icc	Circuit current	Quiescent	1	OFF	OFF	OFF	OFF	OFF	OFF	OFF	a	PIN23	33	45	57	mA
	VREF	Reference voltage	↑	↑	↑	↑	↑	↑	↑	↑	↑		PIN25	5.3	5.8	6.3	V
	VFIL	Filter voltage	↑	↑	↑	↑	↑	↑	↑	↑	↑		PIN57	8.2	8.9	-	V
Logic input	IiH	"H" level input current	ViH = 4.5V	-	↑	↑	↑	↑	↑	↑	↑	b	PIN20 PIN21 PIN22	0.3	1	3	μA
	IiL	"L" level input current	ViL = 0.5V	-	↑	↑	↑	↑	↑	↑	↑		↑	- 0.3	0	0.3	μA
	ViH	"H" level input voltage	(Recommended condition)	-	↑	↑	↑	↑	↑	↑	↑		↑	3.6	4.5	5	V
	ViL	"L" level input voltage	(Recommended condition)	-	↑	↑	↑	↑	↑	↑	↑		↑	0	0.5	1.4	V
Logic output	VPTH	PORT0	IoH = - 1mA	1	OFF	OFF	OFF	OFF	OFF	OFF	a	PIN32	3.5	4.4	-	V	
	VPTL		IoL = 4mA	2	↑	↑	↑	↑	↑	↑	↑	PIN32	-	0.3	0.5		
	IP1H	PORT1	VoH = 9V	1	↑	↑	↑	↑	↑	↑	↑		PIN31	-	0	20	μA
	VP1L		IoL = 5mA	3	↑	↑	↑	↑	↑	↑	↑		PIN31	-	0	0.5	V
	IP2H	PORT2	VoH = 9V	1	↑	↑	↑	↑	↑	↑	↑		PIN30	-	0	20	μA
	VP2L		IoL = 5mA	4	↑	↑	↑	↑	↑	↑	↑		PIN30	-	0	0.5	V
	IP3H	PORT3	VoH = 9V	1	↑	↑	↑	↑	↑	↑	↑		PIN29	-	0	20	μA
	VP3L		IoL = 5mA	5	↑	↑	↑	↑	↑	↑	↑		PIN29	-	0	0.5	V
	IP4H	PORT4	VoH = 9V	1	↑	↑	↑	↑	↑	↑	↑		PIN28	-	0	20	μA
	VP4L		IoL = 5mA	6	↑	↑	↑	↑	↑	↑	↑		PIN28	-	0	0.5	V
	IP5H	PORT5	VoH = 9V	1	↑	↑	↑	↑	↑	↑	↑		PIN27	-	0	20	μA
	VP5L		IoL = 5mA	7	↑	↑	↑	↑	↑	↑	↑		PIN27	-	0	0.5	V
	IP6H	PORT6	VoH = 9V	1	↑	↑	↑	↑	↑	↑	↑		PIN19	-	0	20	μA
	VP6L		IoL = 5mA	8	↑	↑	↑	↑	↑	↑	↑		PIN19	-	0	0.5	V
	IP7H	PORT7	VoH = 9V	1	↑	↑	↑	↑	↑	↑	↑		PIN18	-	0	20	μA
	VP7L		IoL = 5mA	9	↑	↑	↑	↑	↑	↑	↑		PIN18	-	0	0.5	V
VP8H	PORT8	IoH = - 1mA	1	↑	↑	↑	↑	↑	↑	↑		PIN17	3.5	4.4	-	V	
VP8L		IoL = 4mA	10	↑	↑	↑	↑	↑	↑	↑		PIN17	-	0.3	0.5		
IP8OPEN		Vo = 0V~5V	11	↑	↑	↑	↑	↑	↑	↑		PIN17	- 20	-	20		μA
Selector	Gvs	Gain	Vi = - 25dBV	12~15	ON	ON	↑	↑	↑	↑	↑	↑	A(1), A(2)	- 1.0	0	1.0	dB
	THDs	Total harmonic distortion	Vi = -25dBV, 400Hz to 30kHz	12~15	↑	↑	↑	↑	↑	↑	↑	↑	A(1), A(2)	-	0.01	0.1	%
	THDSmax	Maximum total harmonic distortion	Vi = -14dBV, 400Hz to 30kHz	12~15	↑	↑	↑	↑	↑	↑	↑	↑	A(1), A(2)	-	0.1	1.0	%
Switching offset	OFSTM1	Treble/mid switching offset voltage	No signals (measure of data switching offset)	16→17	OFF	OFF	↑	↑	↑	↑	↑		PIN14 PIN35	- 20	0	+ 20	mV
	OFsBB1	Boost switching offset voltage 1	↑	1→18	↑	↑	↑	↑	↑	↑	↑		PIN8 PIN41	- 10	0	+ 10	mV
	OFsBB2	Boost switching offset voltage 2	↑	1→19	↑	↑	↑	↑	↑	↑	↑		PIN8 PIN41	- 10	0	+ 10	mV

6249826 0022200 175



ELECTRONIC SOUND CONTROL WITH ELECTRONIC VOLUME FOR MULTIPLE SOURCES

ELECTRICAL CHARACTERISTICS (Continued)

Block name	Symbol	Parameter	Test conditions								Test point	Limits			Unit		
			Input condition	Number of data	SW conditions							SD	Min	Typ		Max	
					SA 1	SA 2	SB 1	SB 2	SC 1	SC 2							
Channel balance	CBVT	Total channel balance 1	-	-	-	-	-	-	-	-	-	CB + CBT	-3	0	3	dB	
	CBVM	Total channel balance 2	-	-	-	-	-	-	-	-	-	CB + CBM	-3	0	3	dB	
	CBVB	Total channel balance 3	-	-	-	-	-	-	-	-	-	CB + CBBA	-3	0	3	dB	
	ATT(min)	Minimum attenuation level	Reference ^① Vi=-14dBV	1	OFF	OFF	ON	ON	OFF	OFF	a	B(1),B(2)	7.2	9	10.8	dB	
Electronic volume	CB	Channel balance	↑	↑	↑	↑	↑	↑	↑	↑	↑	B(1)/B(2)	-1.8	0	1.8	dB	
	THD	Total harmonic distortion	Vi=-14dBV, BPF =400Hz to 30kHz ^①	↑	↑	↑	↑	↑	↑	↑	↑	B(1),B(2)	-	0.02	0.1	%	
	No(min)	Noise voltage	Quiacet, JIS - A	↑	↑	↑	OFF	OFF	↑	↑	↑	↑	-	25	56	μVrms	
	THDmax	Maximum total harmonic distortion	Vi=-3dBV, BPF =400Hz to 30kHz ^①	1	↑	↑	ON	ON	↑	↑	↑	↑	-	0.1	1.0	%	
	ATT(-10)	Attenuation(-10dB)	Reference ^① Vi=-14dBV	20	↑	↑	↑	↑	↑	↑	↑	↑	-2.8	-1.0	0.8	dB	
	ATT(max)	Maximum attenuation	Vi = -3dBV, JIS - A ^①	21	↑	↑	↑	↑	↑	↑	↑	↑	-	-97	-77	dB	
	No	Noise voltage under maximum attenuation	Quiacet, JIS - A	21	↑	↑	OFF	OFF	↑	↑	↑	B(1),B(2)	-	10	20	μVrms	
	CT	Crosstalk	Vi = -3dBV, JIS - A ^①	1	↑	↑	OFF	ON	OFF	ON	↑	B(1) B(2)	-	-90	-70	dB	
	Treble	GVT	Gain	Reference ^② Vi=-14dBV	1	OFF	OFF	OFF	OFF	ON	ON	a	D(1),D(2)	-6	-4	-2	dB
		CBT	Channel balance	↑	↑	↑	↑	↑	↑	↑	↑	↑	D(1)/D(2)	-2	0	+2	dB
THDH		Total harmonic distortion	↑BPF=400Hz to 30kHz	↑	↑	↑	↑	↑	↑	↑	↑	D(1),D(2)	-	0.01	0.1	%	
NoT		Noise voltage	Quiacet, JIS - A	1	↑	↑	↑	↑	OFF	OFF	↑	↑	-	11	22	μVrms	
THDTmax		Maximum total harmonic distortion	Vi=-6dBV, BPF =400Hz to 30kHz ^②	22	↑	↑	↑	↑	ON	ON	↑	↑	-	0.1	1	%	
GVT(max)		Maximum gain	Reference ^② Vi=-14dBV	22	↑	↑	↑	↑	↑	↑	↑	↑	+10	+12	+14	dB	
GVT(min)		Minimum gain	↑	23	↑	↑	↑	↑	↑	↑	↑	D(1),D(2)	-16	-14	-12	dB	
CTT		Crosstalk	Reference Vi=-6dBV JIS-A ^③	22	↑	↑	↑	↑	OFF	ON	ON	D(1) D(2)	-	-80	-60	dB	
Mid	GVM	Gain	Reference ^③ Vi=-14dBV	1	OFF	OFF	OFF	OFF	ON	ON	a	D(1),D(2)	-6	-4	-2	dB	
	CBM	Channel balance	↑	↑	↑	↑	↑	↑	↑	↑	↑	D(1)/D(2)	-2	0	+2	dB	
	THDM	Total harmonic distortion	↑BPF = 400Hz~30kHz	↑	↑	↑	↑	↑	↑	↑	↑	D(1),D(2)	-	0.01	0.1	%	
	NoM	Noise voltage	Quiacet, JIS - A	1	↑	↑	↑	↑	OFF	OFF	↑	↑	-	11	22	μVrms	
	THDMmax	Maximum total harmonic distortion	Vi=0dBV, BPF =400Hz to 30kHz ^③	24	↑	↑	↑	↑	ON	ON	↑	↑	-	0.1	1	%	
	GVM(max)	Maximum gain	Reference ^③ Vi=-14dBV	24	↑	↑	↑	↑	↑	↑	↑	↑	+4	+6	+8	dB	
	GVM(min)	Minimum gain	↑	25	↑	↑	↑	↑	↑	↑	↑	D(1),D(2)	-16	-14	-12	dB	
	CTM	Crosstalk	Reference Vi=-6dBV JIS-A ^④	24	↑	↑	↑	↑	OFF	ON	ON	D(1) D(2)	-	-80	-60	dB	
Bass	GVBA	Gain	Reference ^④ Vi=-14dBV	1	OFF	OFF	OFF	OFF	ON	ON	a	C(1),C(2)	-6	-4	-2	dB	
	CBBA	Channel balance	↑	↑	↑	↑	↑	↑	↑	↑	↑	C(1)/C(2)	-2	0	+2	dB	
	THDBA	Total harmonic distortion	↑BPF = 400Hz~30kHz	↑	↑	↑	↑	↑	↑	↑	↑	C(1),C(2)	-	0.01	0.1	%	
	NoBA	Noise voltage	Quiacet, JIS - A	1	↑	↑	↑	↑	OFF	OFF	↑	↑	-	10	20	μVrms	
	THDBAmax	Maximum total harmonic distortion	Vi=-6dBV, BPF =400Hz to 30kHz ^④	26	↑	↑	↑	↑	ON	ON	↑	↑	-	0.1	1	%	
	GVBA(max)	Maximum gain	Reference ^④ Vi=-14dBV	26	↑	↑	↑	↑	↑	↑	↑	↑	10	12	14	dB	
	GVBA(min)	Minimum gain	↑	27	↑	↑	↑	↑	↑	↑	↑	C(1),C(2)	-16	-14	-12	dB	
	CTBA	Crosstalk	Reference Vi=-6dBV JIS-A ^④	26	↑	↑	↑	↑	OFF	ON	ON	C(1) C(2)	-	-80	-60	dB	
	THDBBmax	Boost maximum total harmonic distortion	Vi=-22dBV, BPF =400Hz to 30kHz ^④	28	↑	↑	↑	↑	ON	ON	↑	C(1),C(2)	-	0.1	1	%	
	GVBB(max)	Boost maximum total harmonic gain	Vi = -10dBV ^④	18	↑	↑	↑	↑	↑	↑	↑	↑	10	12	14	dB	
GVBB(min)	Boost minimum total harmonic gain	↑	19	↑	↑	↑	↑	↑	↑	↑	C(1),C(2)	-22	-20	-18	dB		

Note 1. Vi : Input voltage ① = VCA, ② = HPF, ③ = BPF, ④ = LPF

6249826 0022201 001



ELECTRONIC SOUND CONTROL WITH ELECTRONIC VOLUME FOR MULTIPLE SOURCES

DIGITAL CONTROL SPECIFICATIONS

Data format (Refer to data setting table in the next page)

	8bit	4bit	4bit	4bit	4bit	4bit												2bit			
MSB	Volume	Treble	Mid	Bass	Super bass	SEL				PORT	PORT	PORT	PORT	PORT	PORT	PORT	PORT	PORT	PORT8		LSB
						1	2	3	4	0	1	2	3	4	5	6	7	1	2		
VOLUME		: 00 to FF (8BIT D/A DATA)				SEL				: 4BITS FOR INPUT SWITCHING											
TREBLE		: 0 to D (14 STEPS)				PORT0				: TTL OUTPUT											
MID		: 0 to A (11 STEPS)				PORT1 to 7				: OPEN COLLECTOR OUTPUT											
BASS		: 0 to D (14 STEPS)				PORT8				: 2BITS ; 3-STATE OUTPUT											
SUPER BASS		: 0																			
		1 to 5																			
		9 to D																			

TIMING CHART (Recommended conditions)

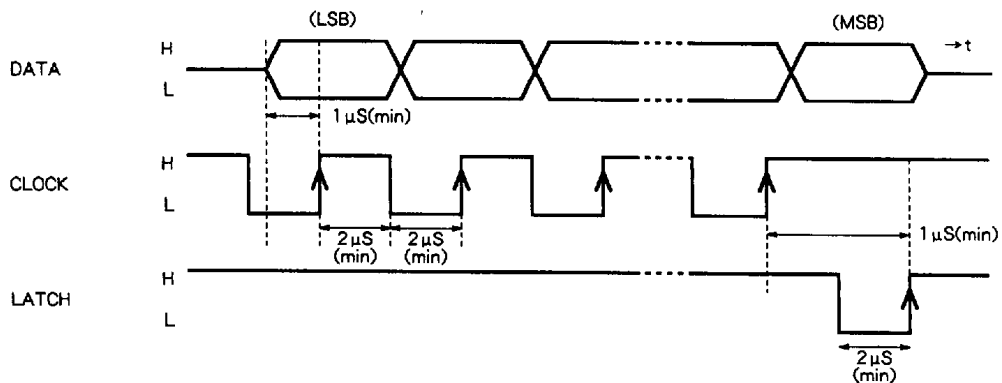

Note 1. CLOCK and LATCH are operat at rising edges of pulse.
 2. Logic input buffer threshold voltage is about 2.5V.

ELECTRONIC SOUND CONTROL WITH ELECTRONIC VOLUME FOR MULTIPLE SOURCES

VCA, tone data setting table

D/A converter for VCA		Treble		Mid		Bass		Super bass	
Data	Setting	Data	Setting	Data	Setting	Data	Setting	Data	Setting
00	V_z	0	- 10dB	0	- 10dB	0	- 10dB	0	± 0dB
01	$\frac{255V_z + V_F}{256}$	1	- 8dB	1	- 8dB	1	- 8dB	1	- 2dB
		2	- 6dB	2	- 6dB	2	- 6dB	2	+ 4dB
		3	- 4dB	3	- 4dB	3	- 4dB	3	+ 6dB
		4	- 2dB	4	- 2dB	4	- 2dB	4	+ 9dB
		5	± 0dB	5	± 0dB	5	± 0dB	5	+ 12dB
		6	+ 2dB	6	+ 2dB	6	+ 2dB	6	-
		7	+ 4dB	7	+ 4dB	7	+ 4dB	7	-
		8	+ 6dB	8	+ 6dB	8	+ 6dB	8	-
		9	+ 8dB	9	+ 8dB	9	+ 8dB	9	- 2dB
		A	+ 10dB	A	+ 10dB	A	+ 10dB	A	- 4dB
		B	+ 12dB	B	-	B	+ 12dB	B	- 6dB
C	+ 14dB	C	-	C	+ 14dB	C	- 9dB		
D	+ 16dB	D	-	D	+ 16dB	D	- 12dB		
FE	$\frac{2V_z + 254V_F}{256}$	E	-	E	-	E	-	E	-
FF	$\frac{V_z + 255V_F}{256}$	F	-	F	-	F	-	F	-

Note 1. All data is design values. Vz and V_F are internal power supply voltages. Between +12dB and +16dB of treble and bass are for loudness control.

2. Data is shown by the hexadecimal notation.

Input selector, output port data setting table

SELECTOR				PORT 0		PORT 1~7		PORT8		
Data				Data	Output TTLOUT	Data	Output open collector	Data		
1	2	3	4					1	2	
L	L	L	H	H	H(TTL)	H	OPEN	H	H	H(TTL)
L	L	H	L	L	L(TTL)	L	CLOSE	H	L	L(TTL)
L	H	L	L	-	-	-	-	L	Note3	High Impedance
H	L	L	L	-	-	-	-	-	-	-

Note 3. "L" or "H"

VCA attenuation (Reference)

Control data (D/A converter)	VCA attenuation (dB)
0F	(maximum attenuation)
1F	- 79
2F	- 59
3F	- 44
4F	- 32
5F	- 23
6F	- 15
7F	- 9
8F	- 4
9F	0
AF	+ 3
BF	+ 5
CF	+ 6
DF	+ 7
EF	+ 8
FF	+ 9

6249826 0022203 984



ELECTRONIC SOUND CONTROL WITH ELECTRONIC VOLUME FOR MULTIPLE SOURCES

ANALOG SIGNAL PROCESSING

(Basic construction (One channel))

(Total gain : +5dB (VCA max))

(Tone section gain (Reference) : -4dB)

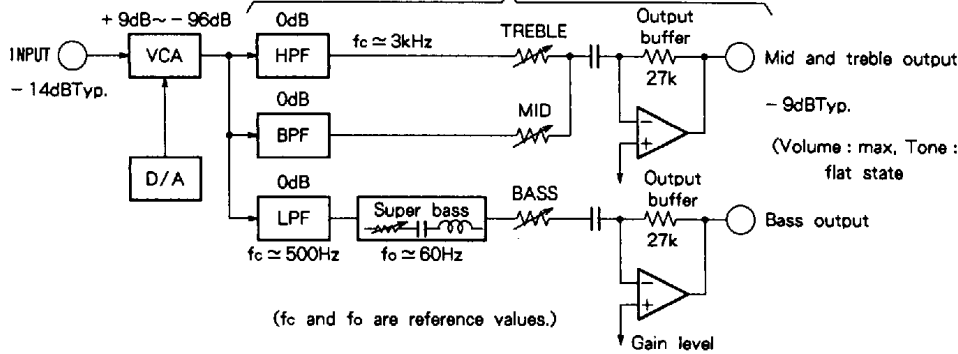

(f_c and f_o are reference values.)

Gain level

(All data is design values.)

Volume : +9dB to -96dB TYP.

(VCA)

Treble : 10dB~0dB to +10dB (2dB/steps)

(For loudness control, +12dB, +14dB, +16dB)

Mid : -10dB~0dB to +10dB (2dB/steps)

Bass : -10dB~0dB to +10dB (2dB/steps)

(For loudness control, +12dB, +14dB, +16dB)

Super bass : -12dB~0dB to +12dB

Data setting table

Data No.	Control data																		
	Volume, tone (indicate hexadecimal)						Input selector and output port (indicate binaries)												
	VCA	Treble	Mid	Bass	Super bass	Input selector					PORT 0	PORT 1	PORT 2	PORT 3	PORT 4	PORT 5	PORT 6	PORT 7	PORT 8
1	F	F	5	5	5	0	0	0	0	0	1	1	1	1	1	1	1	1	1
2											0	1	↓						
3											1	0	1	↓					
4											1	0	1	↓					
5												1	0	1	↓				
6													1	0	1	↓			
7														1	0	1	↓		
8															1	0	1	↓	
9																1	0	↓	1
10									↓								1	1	0
11								0	↓										0
12								1	0	↓									1
13								0	1	0	↓								1
14									0	1	0								
15			5	5					0	1									
16			D	0						0									
17			0	A		0													
18	↓	↓	5	5		5													
19	F	F				D													
20	9	8	↓			0													
21	0	0	5																
22	F	F	D	↓															
23			0	5															
24			5	A	↓														
25				0	5														
26				5	D	↓													
27	↓	↓	5	↓	0	0	↓	↓	↓	↓	↓	↓	↓	↓	↓	↓	↓	↓	↓
28	F	F	5	5	D	5	0	0	0	0	1	1	1	1	1	1	1	1	1

ELECTRONIC SOUND CONTROL WITH ELECTRONIC VOLUME FOR MULTIPLE SOURCES

TEST CIRCUIT

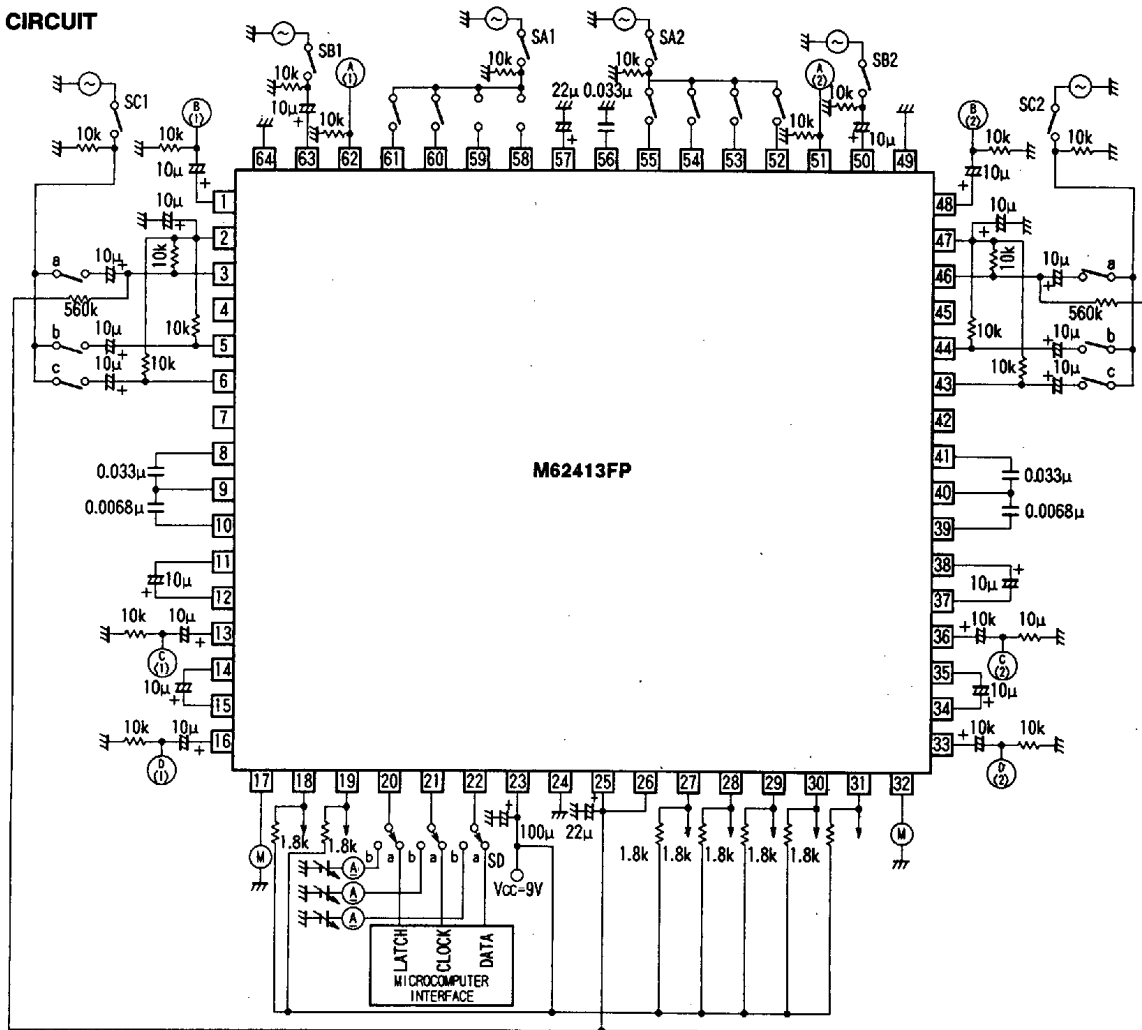

Units Resistance : Ω
Capacitance : F

TYPICAL CHARACTERISTICS

VCA ATTENUATION VS. DA OUTPUT VOLTAGE

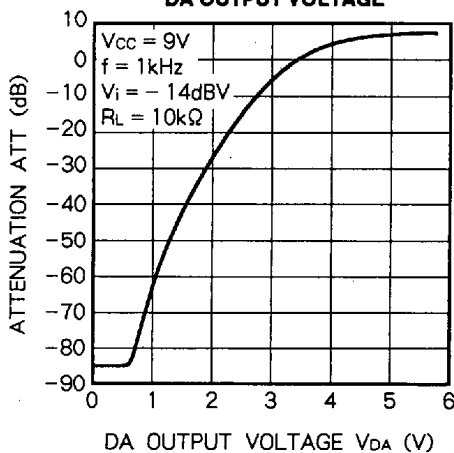

CIRCUIT CURRENT, REFERENCE-FILTER VOLTAGE VS. SUPPLY VOLTAGE

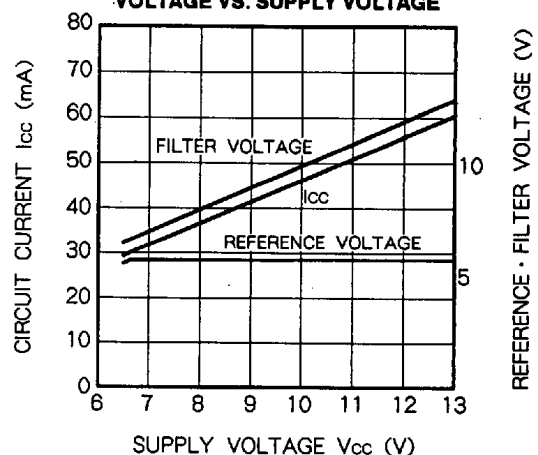

6249826 0022205 757



ELECTRONIC SOUND CONTROL WITH ELECTRONIC VOLUME FOR MULTIPLE SOURCES

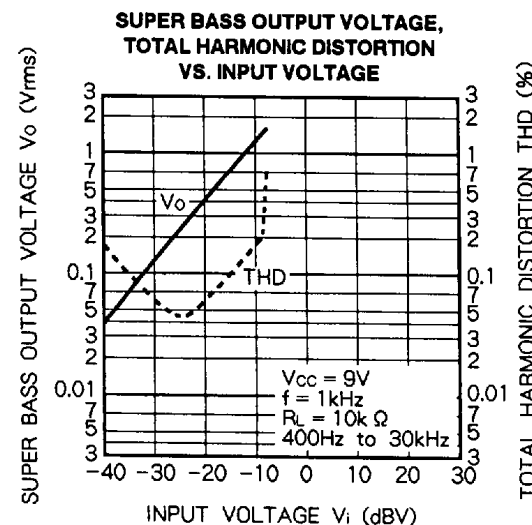
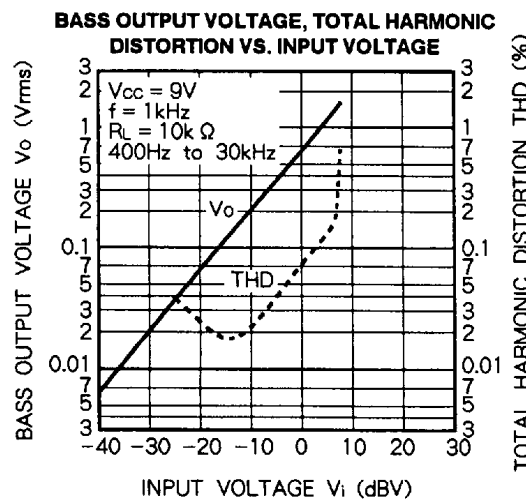
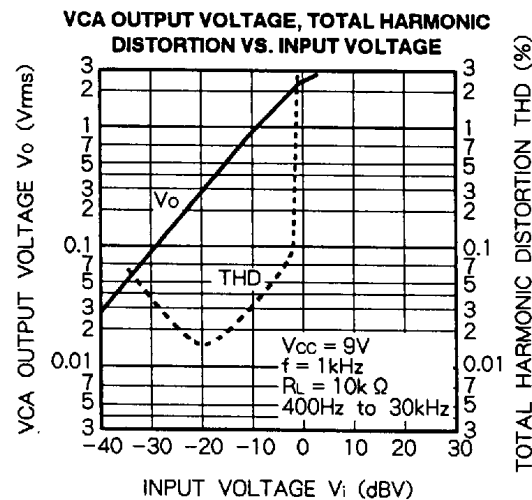
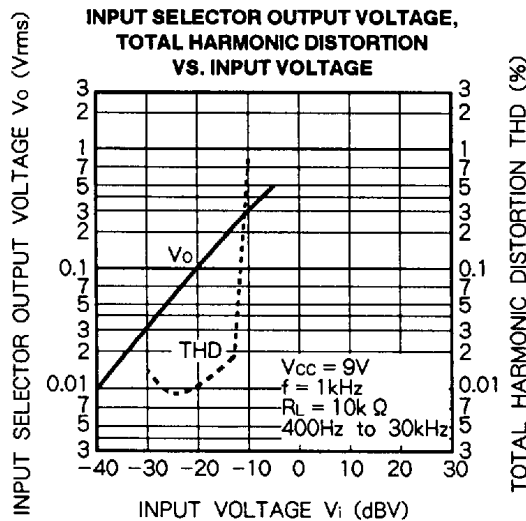
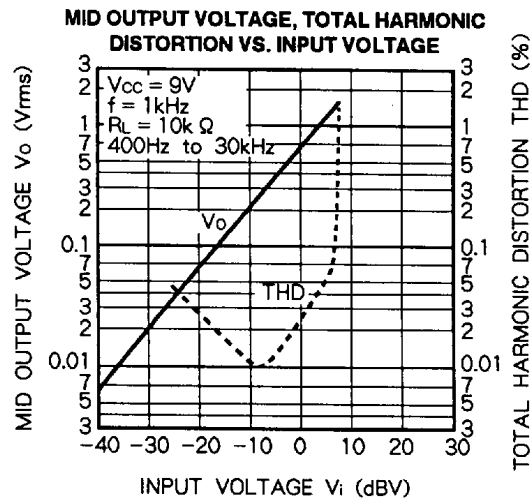
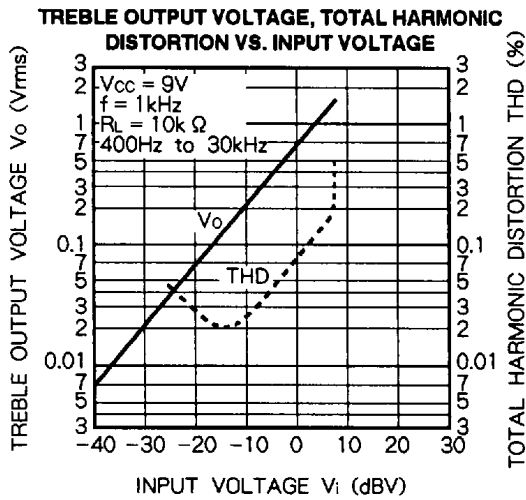

6249826 0022206 693



ELECTRONIC SOUND CONTROL WITH ELECTRONIC VOLUME FOR MULTIPLE SOURCES

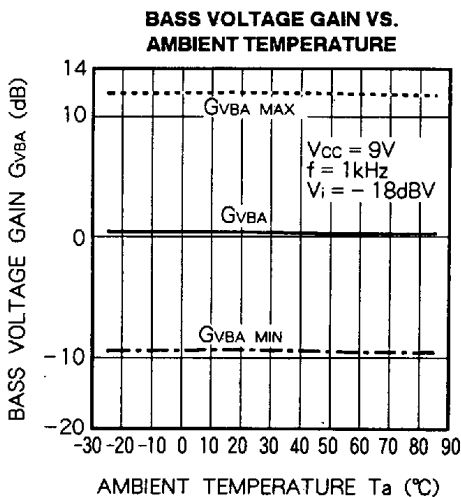
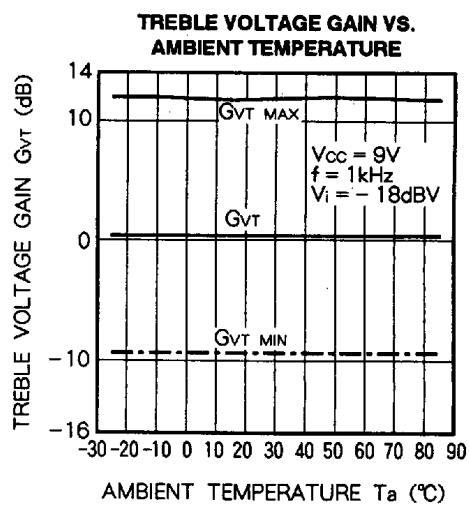
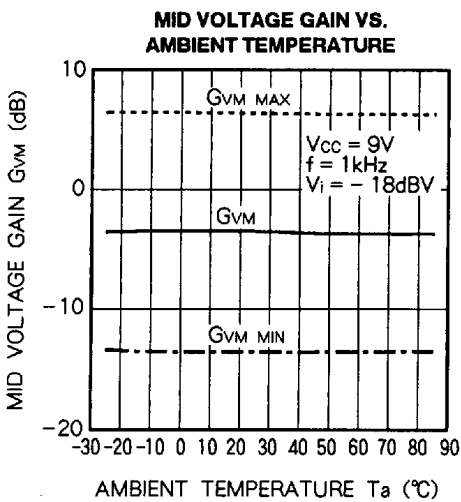
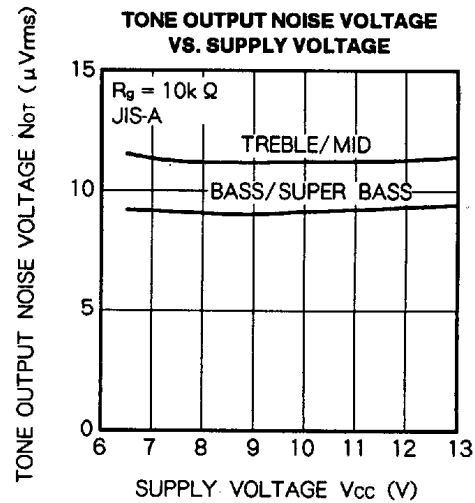
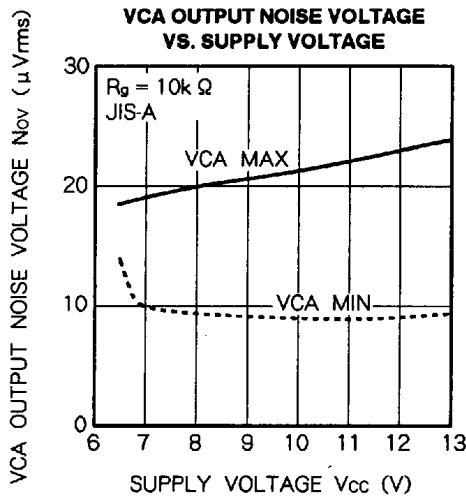

ELECTRONIC SOUND CONTROL WITH ELECTRONIC VOLUME FOR MULTIPLE SOURCES

APPLICATION EXAMPLE

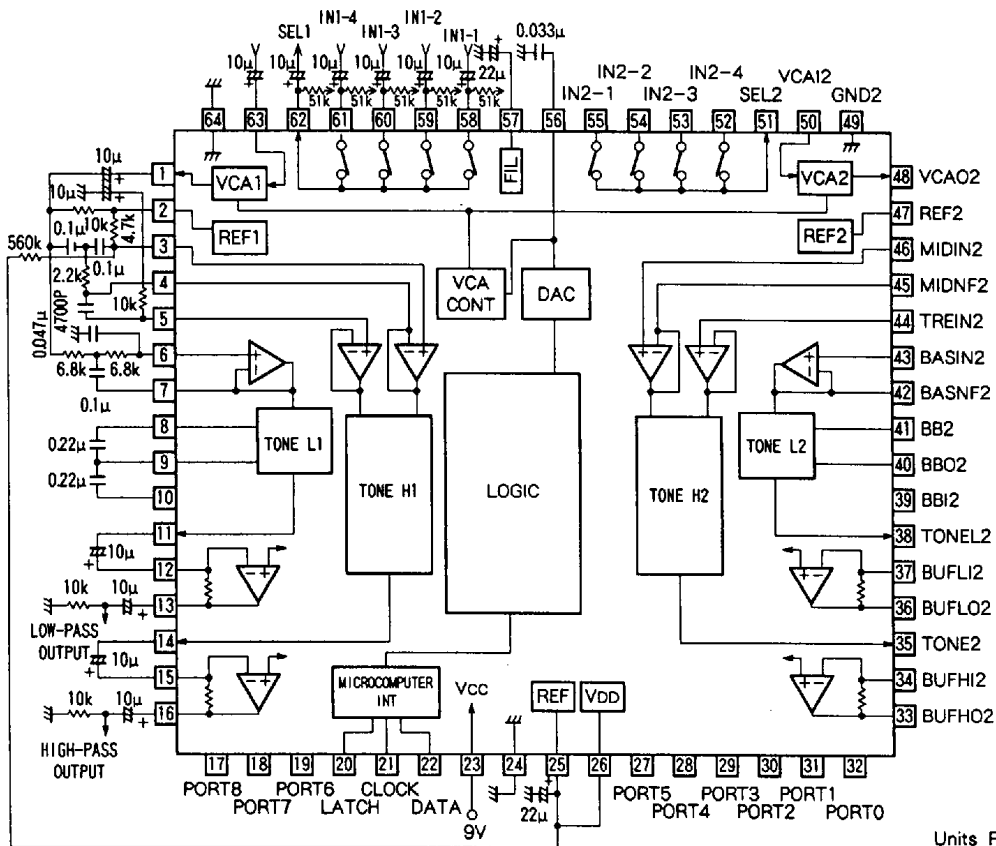

Units Resistance : Ω
Capacitance : F