

# 10Gb/s Compact InP MZ Modulator with DWDM Laser

## LMC10NEG

### Negative Chirp - High Power

The LMC10NEG product, containing the Bookham Ultra High Power Strained Layer DFB laser chip and negative chirp InP MZ modulator, has been specifically designed for use in 10 Gb/s high performance regional metro and long haul DWDM systems. By co-packaging the laser, locker, modulator and MZ Bias Control Tap in a package with the same footprint area as the industry standard 14-pin, the LMC10 series provides Mach-Zehnder performance at a price similar to lower performance alternatives. The provision of the MZ bias control tap offers the option of MZ bias point optimisation for best transmitted optical waveform over life. The high output power, integral wavelength locking and high extinction ratio provides excellent OSNR to allow the device to be employed on multi-span long haul links.

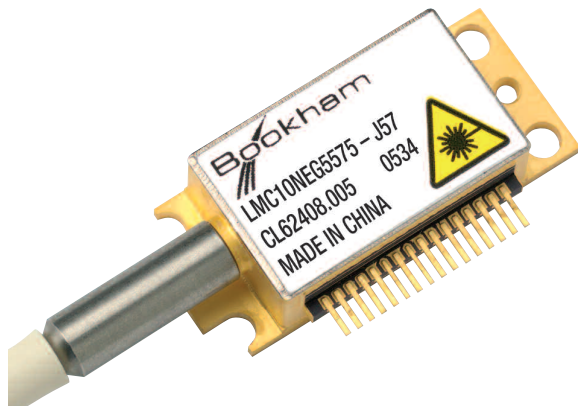

### Features:

- Mean modulated power  $>+4\text{dBm}$  over life and temperature
- Negative Chirp (up to 1600ps/nm applications)
- Co-planar differential RF drive  $\leq 2.7$  volts
- Suitable for 50GHz ITU applications with  $\pm 20\text{pm}$   $\lambda$  accuracy over life
- Low Power Dissipation
- Industry Standard 14-pin footprint area
- Pins on one side to allow increased system density
- C and L band
- Unrivalled performance vs size
- Qualified to Telcordia GR-468 CORE
- RoHS 5/6 compliant 

### Applications:

- **10Gb/s Long Haul** DWDM multi-span dispersion compensated links
- **Regional Metro** single spans with no dispersion compensation
- **10Gb/s Overlay** for Metro Networks
- **2.5Gb/s Long Haul** DWDM multi-span non dispersion compensated links

## Using the LMC10NEG

The LMC10NEG can be used in two ways:

### Mode 1.

With dynamic modulator arm DC bias control where the MZ bias control tap is used in a control loop to optimise the optical crossing point over life. Details of operating in this mode are given in applications note AN0136.

### Mode 2.

Fixed modulator arm DC bias where the tap function is not used. Backwards compatible with the LMC10NEH device.

## Characteristics

Parameter	Conditions	Min	Typ	Max	Unit
<b>Module and Modulator Parameters</b>					
Case temperature $T_{\text{case}}$	External temperature of Tx case [1]	-5		75	°C
Modulated output power	EOL over temperature	4		7	dBm
Power variation over case temperature	[2]	-1.3		0.5	dB
AC extinction ratio	EOL, 10.709Gb/s [3]	10	11.5		dB
Dispersion penalty over temperature	10.709Gb/s, EOL [4]			2	dB
Data bar arm bias	<9mA arm bias current	-4		-1.1	V
Data arm bias	<9mA arm bias current	-2.2		-0.5	V
Modulation drive voltage	per arm, pk-pk, 10.709Gb/s [5]	1.8		2.7	V
Optical rise time, fall time	20% - 80%			35	ps
Tolerable link optical reflection	[6]			-14	dB
Output optical return loss	[7]	20			dB
Optical crossing level (Mode 1)	[8]	48	50	52	%
Optical crossing level (Mode 2)	[9]	40		60	%
Modulator bandwidth	S21, -3dB	10			GHz

## Characteristics (continued)

Parameter	Conditions	Min	Typ	Max	Unit
<b>Laser Source Parameters</b>					
Laser forward current EOL	C & L-Band. Wavelength locked			305	mA
Change in laser forward current	From SOL to EOL	-20		20	mA
Laser threshold current EOL		20		85	mA
Laser forward voltage	EOL at locked wavelength			2.3	V
Laser linewidth	CW FWHM		5	20	MHz
Side mode suppression ratio [SMSR]	At locked wavelength	40	50		dB
Average relative intensity noise [RIN]	200MHz to 8GHz			-140	dB/Hz

Parameter	Conditions	Min	Typ	Max	Unit
<b>TEC and Thermal Parameters</b>					
Thermistor resistance	For locked wavelength [15]	4500		10100	Ohms
TEC current	EOL, T Case = 75°C			1.1	A
TEC voltage	EOL, T Case = 75°C			3	V
Module power dissipation	EOL, T Case = 75°C		1.5	4	W

Parameter	Conditions	Min	Typ	Max	Unit
<b>Wavelength Locker Parameters</b>					
Etalon photocurrent at locked wavelength	EOL	0.1		2	mA
Reference photocurrent at locked wavelength	EOL	0.1		2	mA
Etalon slope at locked wavelength	EOL [10]	0.3		7	uA/pm
Reference slope at locked wavelength	EOL	0.1		3	uA/pm
Etalon / reference current ratio at locking point	[11]	0.2		2	ratio
Wavelength accuracy over life and temperature	[12]	-20		20	pm
Laser drive current tuning coefficient	[13]	3	4	7	pm/mA

**Note:**

AC parameters such as extinction ratio and waveform crossing may be system dependent.

### Characteristics (continued)

Parameter	Conditions	Min	Typ	Max	Unit
<b>Bias Control Tap Parameters</b>					
Tap bias voltage	[14]	-5.1	-5		V
Tap photocurrent				10	mA

### S11 Test Mask

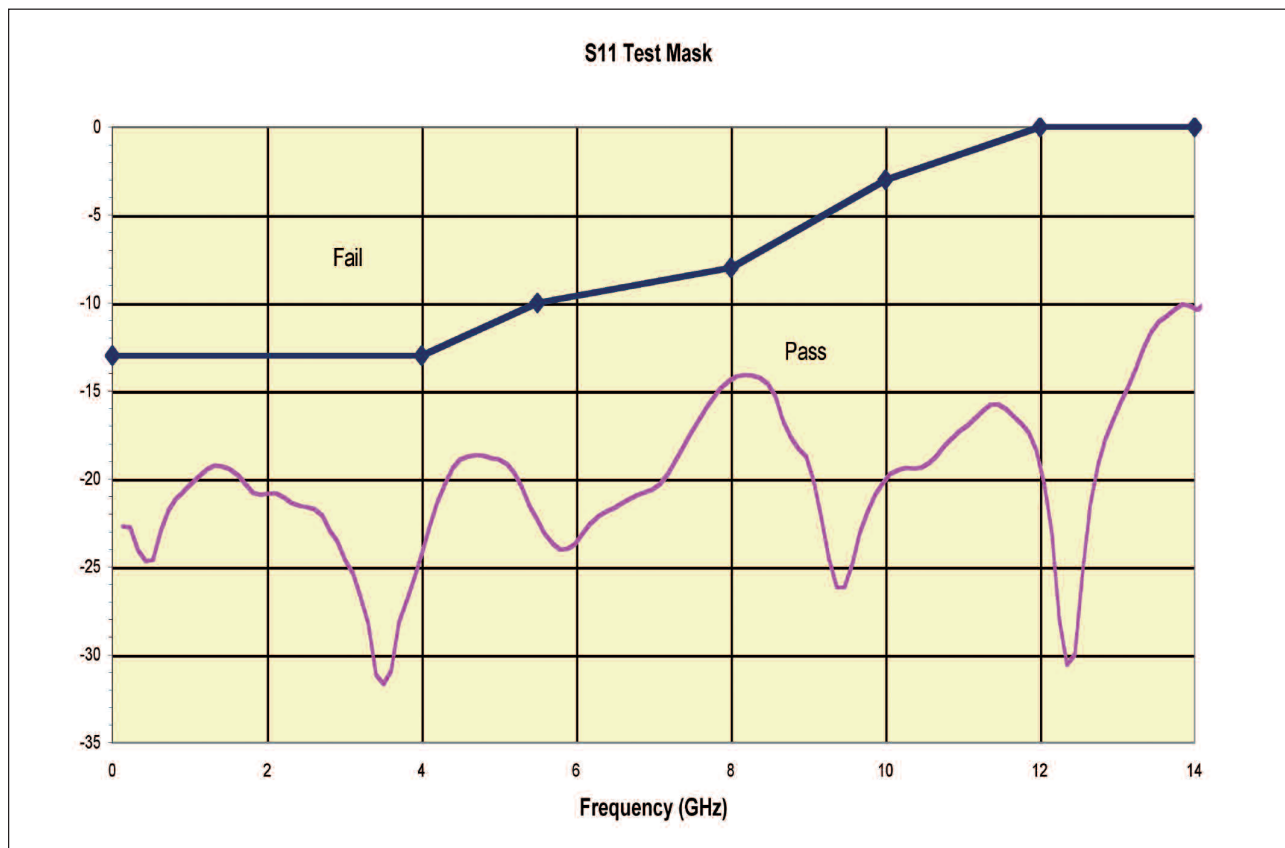

**Note:** AC parameters such as extinction ratio and waveform crossing may be system dependent.

## Glossary

BFM	Back Facet Monitor diode	SOL	Start of life
CW	Continuous wave	Tcase	Case temperature
EOL	End of life	Pk-pk	Peak to peak
FWHM	Full width half maximum	BCT	Bias Control Tap
MZ	Mach-Zehnder interferometer		

## Notes to Characteristic Tables

- [1] Refer to Bookham applications document AN0117 for Tx case temperature measurement definition.
- [2] Power variation over case temperature is measured reference to 30°C case temperature.
- [3] Measured reference to a high speed sampling oscilloscope (unfiltered). EOL figure does not include modulator driver component ageing if applicable.
- [4] Measured with 1600ps/nm chromatic dispersion, ITU-T G652 optical fibre, 10.709Gb/s, 2<sup>23</sup>-1 PRBS NRZ sequence. The penalty calculation is made at a BER level of 10<sup>-10</sup>. RX OSNR > 30dB [35dB target], RBW of 0.1nm using a Bookham standard receiver with differential drive to modulator. The device is driven directly from a pattern generator. Receiver decision point self optimised for amplitude and phase.
- [5] Measured at the input to the LMC10NEG. Driver selection must take into account modulator driver to transmitter transmission line losses. Refer to Bookham applications document AN0137.
- [6] Optical return loss of plant attached to LMC10NEG fibre connector.
- [7] Optical return loss looking back into the LMC10NEG averaged over polarisation, with target value of -27dB.
- [8] This is a requirement for the crossing control loop over life and temperature. The accuracy over life and temperature will be a function of the control loop circuit design. Reference application note AN0136.
- [9] Assuming 50% crossing level set at start of life. EOL figure does not include modulator driver component ageing if applicable.
- [10] Slope of the etalon signal can be either positive or negative.
- [11] Maintain the start of life locking ratio over life to hold wavelength constant.
- [12] Assumes wavelength is set to ITU wavelength at start of life, closed loop wavelength control by maintaining constant locking ratio.
- [13] Wavelength variation with change in laser drive current at constant temperature.
- [14] The MZ bias control tap responsivity is bias voltage dependent.
- [15] The thermistor current should not exceed 100 µA to prevent self-heating effects. The thermistor resistance varies with temperature according to the following Steinhart-Hart equation, where C1= 1.2156x10<sup>-3</sup>, C2= 2.1925x10<sup>-4</sup>, C3=1.5241x10<sup>-7</sup> for the thermistor type used. Temperature is required in Kelvin.

$$\frac{1}{T} = C_1 + C_2 \ln R + C_3 (\ln R)^3$$

Note: AC parameters such as extinction ratio and waveform crossing may be system dependent.

## Absolute Maximum Ratings

Condition	Min	Typ	Max	Unit
Storage case temperature	-40		85	C
Laser Current			600	mA
Laser Voltage	-2			V
MZ arm voltage (DC) <sup>[1]</sup>	-12		0	V
MZ modulator arm bias currents (DC) <sup>[2]</sup>			12	mA
BFM bias	-15		0	V
MZ bias control tap voltage	-6		0	V
MZ bias control tap current			10	mA
TEC voltage <sup>[5]</sup>	-3		3	V
TEC current <sup>[5]</sup>	-1.8		1.8	A
Output optical power [continuous operation]			13	dBm
Lead soldering temperature <sup>[3]</sup>			260	°C
Fiber bend radius <sup>[4]</sup>	30			mm

### Notes:

[1] With laser off. Do not forward bias the MZ arms or the bias control tap.

[2] Do not exceed the MZ and bias control tap maximum currents.

[3] Maximum soldering time of 10 seconds, Tx case and fiber must not be subjected to extremes of temperature.

[4] Minimum fiber bend radius of 30mm, fiber may be damaged if exceeded.

[5] Thermistor operating range must not be exceeded.

### ESD Rating

This product is ESD compliant to Class 2 as defined by Telcordia TA-TSY-000870. ESD precautions must be used when handling this device and are required in both production and R&D environments.

### Schematic Diagram

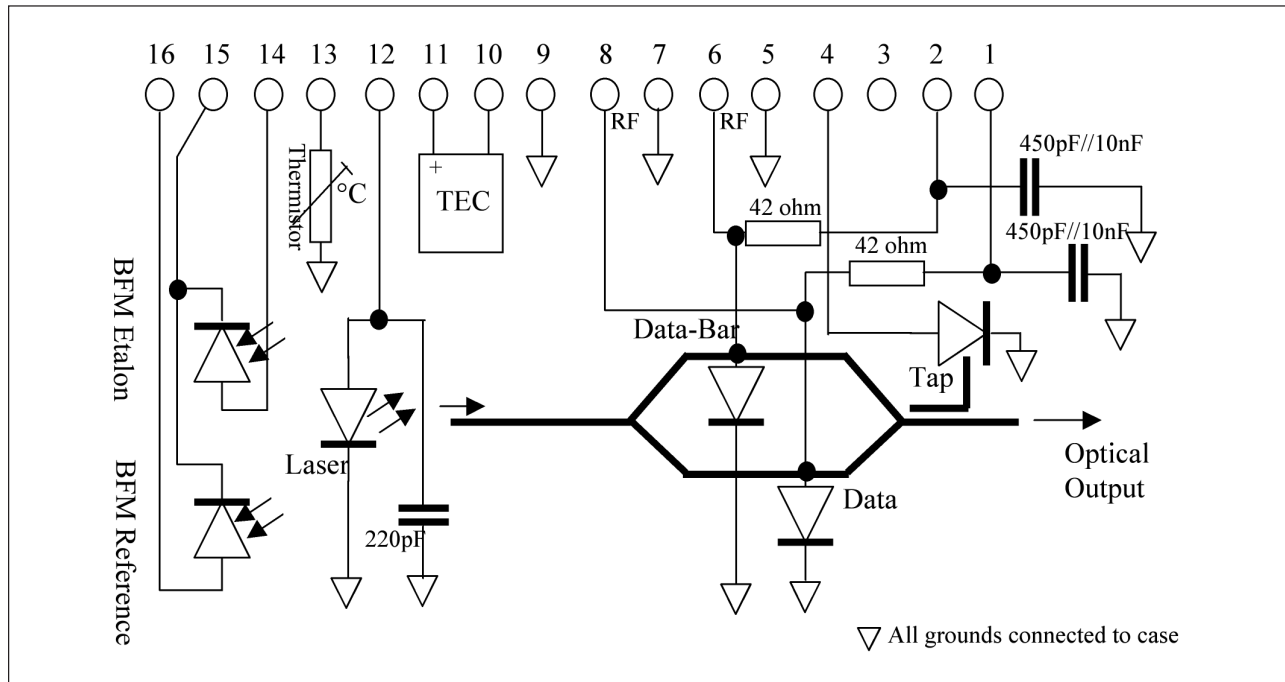

### Pin Out Table

Pin #	Function	Pin #	Function
1	Data bias	9	Case ground
2	Data bar bias	10	TEC -
3	Connect to ground	11	TEC +
4	MZ bias control tap	12	Laser anode
5	Case ground	13	Thermistor
6	Data bar	14	Etalon BFM anode
7	Case ground	15	BFM common cathode
8	Data	16	Reference BFM anode

## Pin Definitions

### Pin 1 MZ data DC Bias input and Pin 2 MZ data-bar DC Bias input

DC bias voltages for data and data-bar MZ arms. These pins must be connected to a low noise negative DC voltage, typically around -2V (WRT case). These voltages are defined for each Tx in the deliverable data. A precision voltage source must be used, which is capable of sourcing up to 10mA to each pin. Refer to Bookham applications note AN0130 for circuit implementation and filtering suggestions.

### Pin 3

Connect to ground.

### Pin 4 Bias Control Tap

The MZ bias control tap pin must be biased to -5V. The supply should be regulated if the device is used in mode 1 as the monitor diode responsivity is voltage dependent.

### Pins 5, 7 and 9 Ground

Package ground connections.

### Pin 6 MZ Data-bar modulation input and Pin 8 MZ Data modulation input

Operation is typically using differential electrical drive voltages applied to both the Data and Data-bar MZ Modulator inputs. Typical amplitude is 2.0V peak-to-peak. AC RF coupling must be used.

### Pin 10 TEC (-) and Pin 11 TEC (+)

The LMC10 contains a Peltier heatpump. Applying a negative voltage on Pin 10 with respect to Pin 11 will cause the internal optics to be cooled relative to the case temperature.

Reversing the applied voltage will cause the internal structures to be heated. The heatpump must be used in a feedback controlled circuit in conjunction with the internal thermistor.

### Pin 12 Laser Anode

The laser is operated with a forward bias current, the laser cathode being connected internally to case ground.

### Pin 13 Thermistor

The thermistor is used in the TEC control loop for keeping the internal temperature at a constant value. It has a nominal resistance of 10k Ohms at a temperature of 25°C and is not polarity sensitive, although one side of the thermistor is connected to package ground. Operating current should be limited to less than 100µA to prevent self heating errors. The exact thermistor value is supplied with each Tx as part of the deliverable test data to ensure the correct operating wavelength.

### Pin 14 Back Facet Monitor Diode Anode (Etalon)

The signal from this diode carries the spectral response of the wavelength filter.

### Pin 15 Back Facet Monitor Diode Common Cathode

Common connection for monitor diode cathodes.

### Pin 16 Back Facet Monitor Diode Anode (Reference)

The signal from this diode is the reference signal and indicates the power of the rear facet of the laser. The signals from the reference and etalon monitor diodes are used in a control loop to maintain the wavelength of the laser at the defined lock point.

## Operating the LMC10NEG

### Control Schemes for the LMC10NEG

#### Arm DC Bias Voltage Control

A dynamic control scheme can be implemented to maintain the bias points on the left and right arms of the MZ modulator at the quadrature point. This will maintain the output pulse train with a 50% eye crossing level. The control circuit needs to track any over life change in the bias points, thereby maintaining the 50% eye crossing condition.

#### Benefits of Using Control Schemes

The product can be used without the control scheme as discussed above. But there are benefits of implementing the control loop:

Maintaining the optical eye crossing to 50% through the life of the product will minimise the variation in extinction ratio and reduce variations in link dispersion penalty.

#### Summary

For more demanding applications at higher link lengths or tighter link budgets the LMC10NEG may be used with a dynamic control scheme which will provide MZ arm bias point control for 50% optical eye crossing.

Use of the BCT in a control loop can offer improved optical eye shape stability compared to open loop performance.



## Wavelength Locker for the LMC10NEG

The wavelength locker for the LMC10NEG includes two photodiodes: the Reference photodiode provides a photocurrent proportional to the laser chip facet power, and the Etalon photodiode provides a photocurrent related to wavelength (frequency).

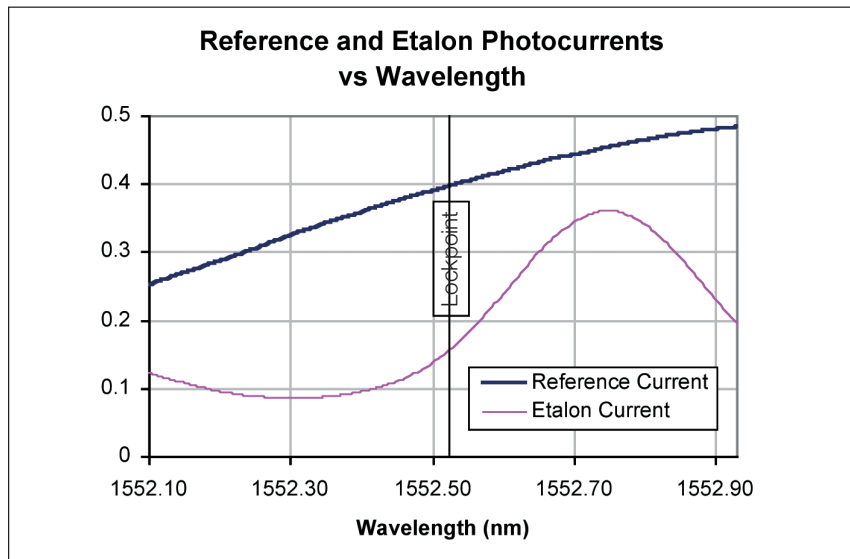

In order to lock the LMC10NEG wavelength, a control circuit should be used which maintains the laser submount temperature constant over life and then controls the wavelength by varying the laser forward current to keep the ratio of the etalon and reference photodiode currents (Locking Ratio) constant. This may be achieved by keeping the discrimination value  $(LR \times I_{ref}) - I_{et}$  at zero, where LR is the target Locking Ratio.

Refer to applications document AN0142 for further information on wavelength locking.

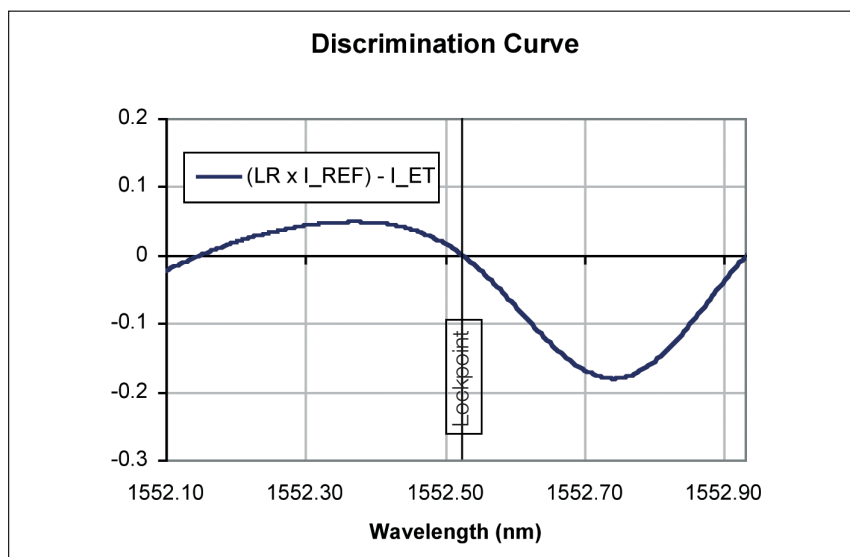

## Package Outline Drawing

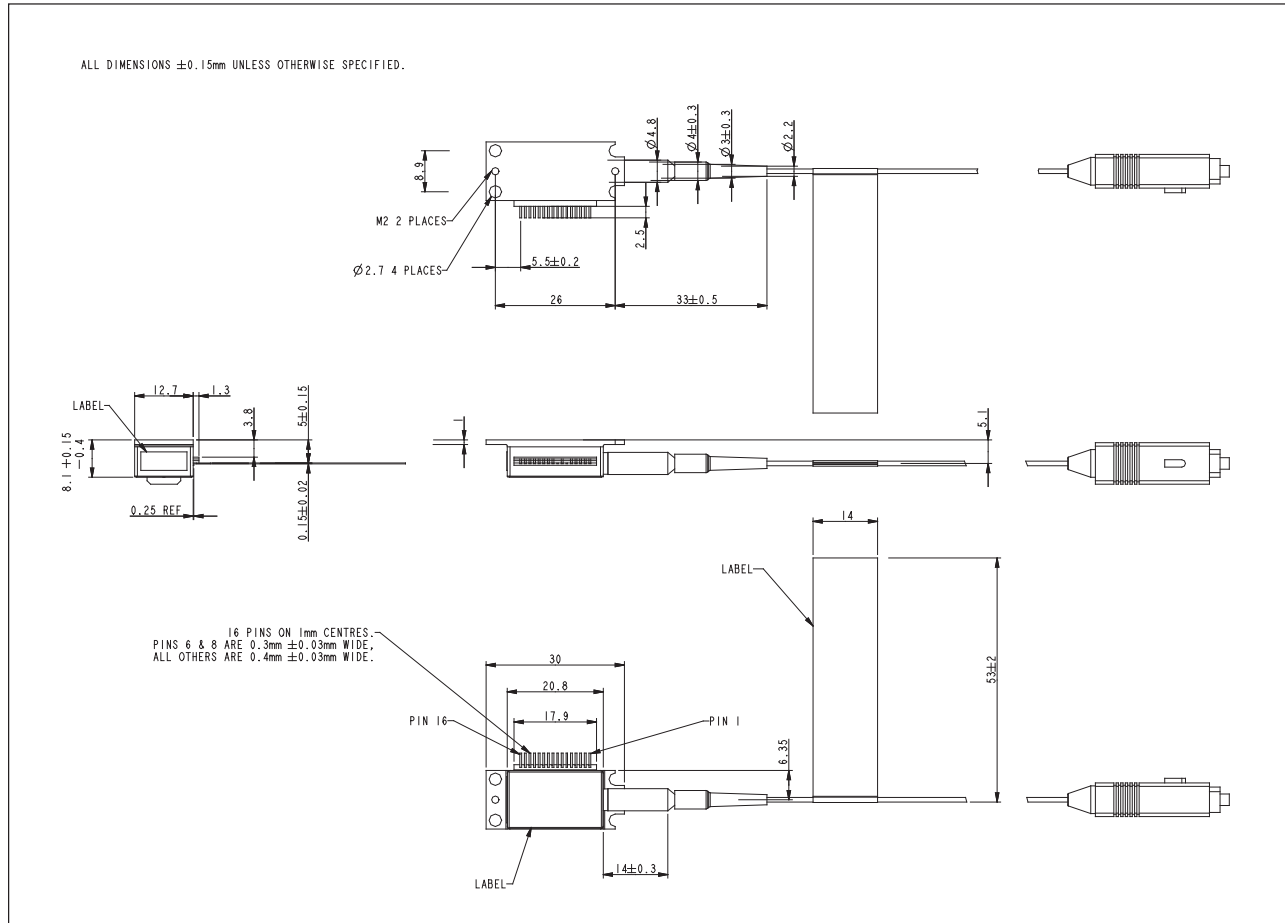

### Typical 10Gb/s Eye Diagram

Test Conditions: 10.709Gb/s 2<sup>23</sup>-1PRBS NRZ data.

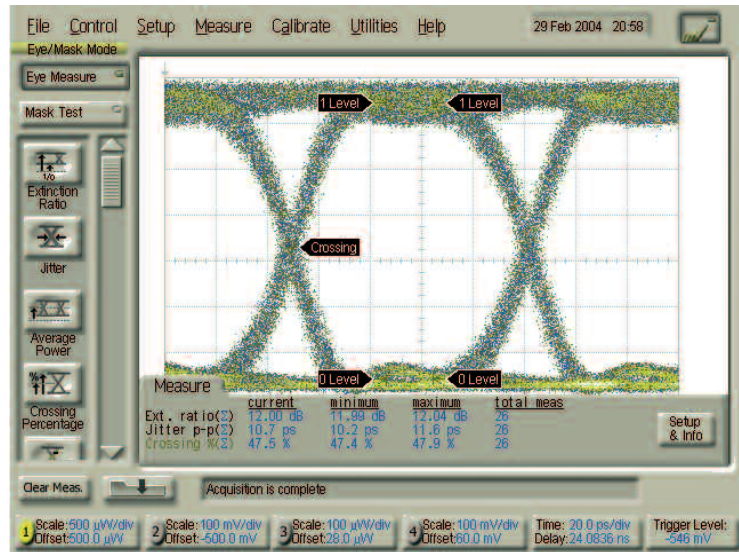

### Typical Over Fibre Performance (SMF-28)

Test Conditions: 10.709Gb/s 2<sup>23</sup>-1PRBS NRZ data, BER10<sup>-12</sup>.

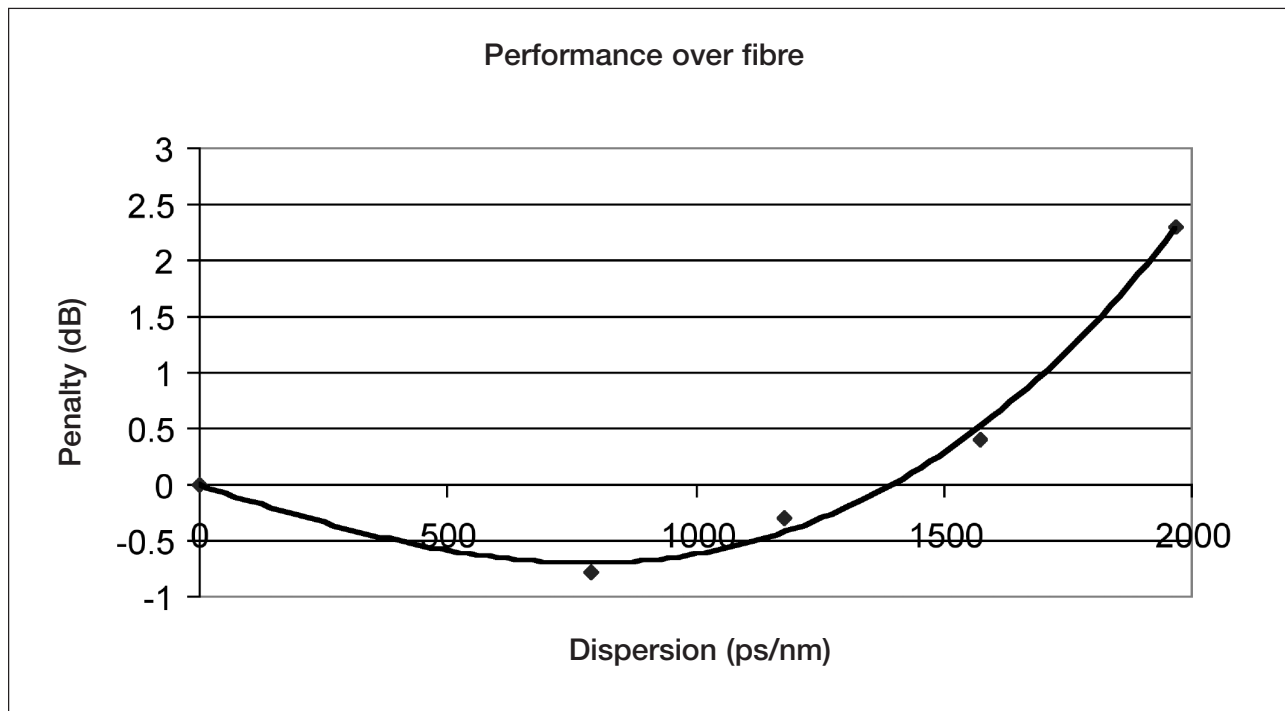

## LMC10 Mounting Guidelines

The device must be attached to a heat-sink capable of dissipating a minimum of 4W without exceeding the maximum case temperature. The surface of the heat-sink must be smooth (< 0.8 micron Ra) and flat (<24.8 microns

over the area and not convex in form). Attachment screws, thermal interface compounds or interface pads may be used but must not exert stress upon the device. Refer to Bookham applications note AN0117.

## Note on Maximum Ratings and Handling Precautions

It is the nature of this device that unprotected semi-conductor junctions are connected directly to external package pins. Protection of these junctions would have an adverse effect on the performance of the device or the flexibility in its application and use. The user is requested to observe the 'Absolute Minimum and Maximum Ratings' in order to prevent damage or destruction of the device. In particular forward biasing the modulator, attenuator or power monitor junctions will lead to catastrophic damage if the current or

voltage limits are exceeded. These junctions are also sensitive to ESD and electrical transients. The laser is similarly sensitive to reverse bias, ESD and electrical transients. These can lead to catastrophic device damage. The user is requested to ensure that operation of any control or bias circuits do not introduce electrical transients or adverse bias conditions during switch-on, switch-off or calibration and set-up routines. Appropriate ESD precautions are required in both production and R&D environments.

## Applications Support

The following application notes are available to support customers using the LMC10NEG:

Component Mounting Recommendations For the Bookham LMC10 InP MZ Transmitter Module	AN0117
LMC10NEG Dynamic MZ Modulator DC Bias Control Recommendations for high Performance Power & Eye Mask Stability	AN0136
Recommended RF drivers for the LMC10 Integrated Optical Transmitter Product Portfolio	AN0137
LMC10 Implementing Dynamic Wavelength Locker Loops For DWDM Optical Systems	AN0142
Characterisation of the LMC10 InP MZ in a 2.5Gb/s Optical Systems Environment	AN0138
Compact LMC10 InP MZ Evaluation Board User Document	AN0130

Optical component evaluation platforms are available for all Bookham Technology optical products. Contact your regional sales representative for further information.

## Deliverable Data

The following deliverable data is provided as a paper copy with each device and can also be made available as a text file from a customer specific site on a Bookham server with password protection.

Parameter	Units
Thermistor operating resistance	Ohms
Laser bias current	mA
Wavelength operating	nm
MZ bias data	Volts
MZ bias data-bar	Volts
Locking reference current	mA
Locking etalon current	mA
Locking current ratio	-
Locker slope sign [1]	+ or -
Laser threshold	mA
MZ drive voltage amplitude	Volts
Wavelength target (ITU-T)	nm
Thermistor temperature	°C
Laser tuning current coefficient	pm/mA
BFM etalon locker slope	μA/pm
BFM reference locker slope	μA/pm
Mean modulated optical power	dBm
AC extinction ratio	dB
Target eye crossing	%

**Note:**

[1] Positive sign indicates etalon photocurrent increasing with wavelength at lock point.  
Refer to Bookham applications document AN0142 for locker slope definitions.

AC specified parameters may be derived from DC measurement data.

## RoHS Compliance



Bookham is fully committed to environment protection and sustainable development and has set in place a comprehensive program for removing polluting and hazardous substances from all of its products. The relevant evidence of RoHS compliance is held as part of our controlled documentation for each of our compliant products. RoHS compliance parts are available to order, please refer to the ordering information section for further details.

### Ordering Information:

LMC10NEG  
 (Wavelength) – (Connector)  
 \*\*\*\* J28 = SC/PC  
 J57 = LC  
 J59 = MU

\*\*\*\* = last four digits of wavelength value  
 e.g. for  $\lambda_p=1533.47\text{nm}$ , \*\*\*\*=3347

WDM wavelength range: C-Band 1528-1565 nm  
 L-Band 1570-1606 nm

Standard fibre length 1000 +/- 100 mm [blue jacket]  
 Other connector types are available on request

To order the LMC10 on an evaluation board, please use the prefix EV in front on the product code e.g. EVLMC10NEG\*\*\*\*-J28

Bookham reserve the right to change without notice.

## Contact Information

### North America Bookham Worldwide Headquarters

2584 Junction Ave.  
 San Jose  
 CA 95134  
 USA

- Tel: +1 408 919 1500
- Fax: +1 408 919 6083

[www.bookham.com](http://www.bookham.com)  
[sales@bookham.com](mailto:sales@bookham.com)

### Europe Paignton Office

Brixham Road  
 Paignton  
 Devon  
 TQ4 7BE  
 United Kingdom

- Tel: +44 (0) 1803 66 2000
- Fax: +44 (0) 1803 66 2801

### Asia Shenzhen Office

2 Phoenix Road  
 Futian Free Trade Zone  
 Shenzhen 518038  
 China

- Tel: +86 755 33305888
- Fax: +86 755 33305805  
 +86 755 33305807

### Important Notice

Performance figures, data and any illustrative material provided in this data sheet are typical and must be specifically confirmed in writing by Bookham before they become applicable to any particular order or contract. In accordance with the Bookham policy of continuous improvement specifications may change without notice. The publication of information in this data sheet does not imply freedom from patent or other protective rights of Bookham or others. Further details are available from any Bookham sales representative.



VISIBLE LASER RADIATION  
 DO NOT VIEW DIRECTLY  
 WITH OPTICAL INSTRUMENTS  
 CLASS 1M LASER PRODUCT  
 REFERENCE IEC 60825-1 Edition 1.2



This product complies with  
 21CFR 1040.10



ISO14001:1996  
 EMS 504193  
 TL9000 Rev 3.0 (ISO9001:2000)  
 FM15040



Caution - use of controls or adjustments or performance of procedures other than those specified herein may result in hazardous radiation exposure.