

Audio processor – companding, VOX and amplifier section

NE/SA5752

PHILIPS INTERNATIONAL

60E D ■ 7110826 0054582 62T ■ PHIN

DESCRIPTION

The NE/SA5752 is a high performance low power audio signal processing system especially designed to meet the requirements for small size and low voltage operation of hand-held equipment. The NE/SA5752 subsystem includes a low noise microphone preamplifier with adjustable gain, a noise cancellation switching amplifier with adjustable threshold, a voice operated transmitter (VOX) switch, VOX control, an audio compressor with buffered input, audio expander, and an internal bandgap voltage regulator with power down capability. When used with Signetics' NE/SA5753, the complete audio processing function of an AMPS or TACS cellular telephone is easily implemented. The system also meets the requirements of the proposed NAMPS or NTACS specifications. The NE/SA5752 can also be used without the NE/SA5753 in a wide variety of radio communications applications.

FEATURES

- Low 3V supply
- Miniature SSOP and SO packages
- High performance
- Adjustable VOX and noise cancellation threshold
- Adjustable gain preamplifier
- Audio companding
- ESD protected
- Open collector VOX output
- Logic inputs CMOS compatible
- Power down mode
- Few external components
- Meets AMPS/TACS/NAMPS/NTACS requirements

BENEFITS

- Very compact applications
- Long battery life in portable equipment
- Complete cellular audio function with the SA5753

APPLICATIONS

- Cellular radio
- Mobile communications
- High performance cordless telephones
- 2-way radio

PIN CONFIGURATION

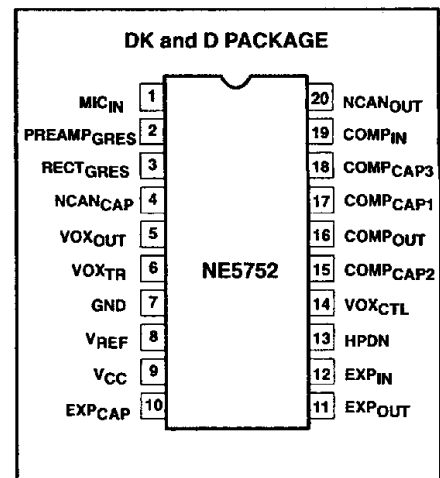

ORDERING INFORMATION

DESCRIPTION	TEMPERATURE RANGE	ORDER CODE
20-Pin Plastic SO	0 to +70°C	NE5752D
20-Pin Plastic SSOP	0 to +70°C	NE5752DK
20-Pin Plastic SO	-40 to +85°C	SA5752D
20-Pin Plastic SSOP	-40 to +85°C	SA5752DK

Audio processor – companding, VOX and amplifier section

NE/SA5752

PHILIPS INTERNATIONAL . 60E D ■ 7110826 0054583 566 ■ PHIN

PIN DESCRIPTIONS

PIN NO.	SYMBOL	DESCRIPTION
1	MIC _{IN}	Microphone input
2	PREAMP _{GRES}	Preamplifier gain resistor
3	RECT _{GRES}	Rectifier gain resistor
4	NCAN _{CAP}	Noise cancellation timing capacitor
5	VOX _{OUT}	Voice operated transmission output
6	VOX _{TR}	Voice operated transmission threshold resistor
7	GND	Ground
8	V _{REF}	Reference voltage
9	V _{CC}	Positive supply
10	EXP _{CAP}	Expander timing capacitor
11	EXP _{OUT}	Expander output
12	EXP _{IN}	Expander input
13	HPDN	Hardware power-down
14	VOX _{CTL}	Voice operated transmission control
15	COMP _{CAP2}	Compressor timing capacitor 2
16	COMP _{OUT}	Compressor output
17	COMP _{CAP1}	Compressor timing capacitor 1
18	COMP _{CAP3}	Compressor timing capacitor 3
19	COMP _{IN}	Compressor input
20	NCAN _{OUT}	Noise cancellation output

BLOCK DIAGRAM

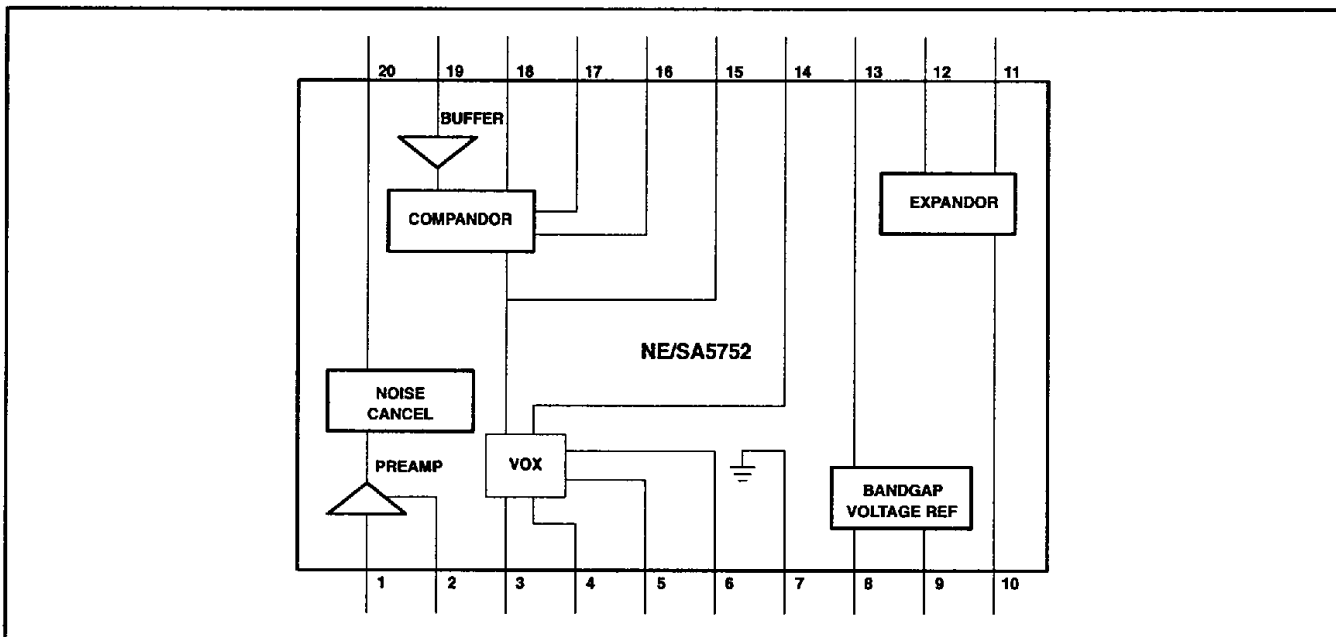

Audio processor – companding, VOX and amplifier section

NE/SA5752

PHILIPS INTERNATIONAL

60E D ■ 7110826 0054584 4T2 ■ PHIN

ABSOLUTE MAXIMUM RATINGS

SYMBOL	PARAMETER	RATING	UNIT
V_{CC}	Power supply voltage range	-0.3 to 6	V
V_{IN}	Voltage applied to any other pin	-0.3 to ($V_{CC}+0.3$)	V
T_{STG}	Storage temperature	-65 to +150	°C
T_A	Ambient operating temperature	NE5752 SA5752 0 to 70 -40 to +85	°C

DC ELECTRICAL CHARACTERISTICS

$T_A = 25^\circ\text{C}$, $V_{CC} = +3.0\text{V}$, $0\text{dB} = 77.5\text{mV}_{\text{RMS}}$. See test circuit, Figure 4.

SYMBOL	PARAMETER	TEST CONDITIONS	LIMITS			UNIT
			MIN	TYP	MAX	
V_{CC}	Supply voltage		2.7	3.0	5.5	V
I_{CC}	Supply current	No signal Power down mode		5.0 200		mA μA
Z_L	Load impedance pins NCAN _{OUT} , EXP _{OUT}		50			k Ω
	COMP _{OUT} ¹		10			k Ω
Z_{IN}	Input impedance COMP _{IN} , MIC _{IN}		40	50	60	k Ω
	EXP _{IN} ²		2.0			k Ω
	Noise cancellation current	Pin 6		25		μA
V_{OS}	DC offset NCAN _{OUT} ³		-50		50	mV

NOTES:

- Compressor is tested in production with 50k Ω load.
- Not tested in production.
- Offset values are identical for both gain states of noise reduction circuit.

AC ELECTRICAL CHARACTERISTICS

$T_A = 25^\circ\text{C}$, $V_{CC} = +3.0\text{V}$, $0\text{dB level} = 77.5\text{mV}_{\text{RMS}}$. See test circuit, Figure 4.

SYMBOL	PARAMETER	TEST CONDITIONS	LIMITS			UNIT
			MIN	TYP	MAX	
	Preamplifier gain range Preamplifier voltage gain 0dB Preamplifier voltage gain 40dB	Pin 2 open Pin 2 AC ground	0 -1.0 39.0	0 40	40 1.0 41.0	dB dB dB
	Preamplifier noise density	Pin 2 AC grounded RS = 50k Ω unweighted 20Hz-20kHz		7		nV/ $\sqrt{\text{Hz}}$
		weighted CCIR DIN45405 20-20kHz		8		nV/ $\sqrt{\text{Hz}}$
	Switch amplifier gain		9	10	11	dB
Compandor 1kHz, all tests¹						
COMP _{OUT}	Compressor error at -21dB output level	Input level = -42dB	-1.0		1.0	dB
COMP _{OUT}	Compressor error at -10dB output level	Input level = -20dB	-1.0		1.0	dB
COMP _{OUT}	Compressor error at 0dB output level	Input level = 0dB	-1.5		1.5	dB
COMP _{OUT}	Compressor error at +5dB output level	Input level = +10dB	-1.0		1.0	dB
COMP _{OUT}	Compressor error at +12.3dB output level	Input level = +24.6dB	-1.0		1.0	dB
EXP _{OUT}	Expander error at -42dB output level	Input level = -21dB	-1.0		1.0	dB

Audio processor – companding, VOX and amplifier section

NE/SA5752

PHILIPS INTERNATIONAL

60E D ■ 7110826 0054585 339 ■ PHIN

EXP _{OUT}	Expander error at -21dB output level	Input level = -10.5dB	-1.0		1.0	dB
EXP _{OUT}	Expander error at -10dB output level	Input level = -5dB	-1.0		1.0	dB

AC ELECTRICAL CHARACTERISTICS

T_A = 25°C, V_{CC} = +3.0V, 0dB level = 77.5mV_{RMS}. See test circuit, Figure 4.

SYMBOL	PARAMETER	TEST CONDITIONS	LIMITS			UNIT
			MIN	TYP	MAX	
EXP _{OUT}	Expander error at 0dB output level	Input level = 0dB	-1.5		1.5	dB
EXP _{OUT}	Expander error at +10dB output level	Input level = +5dB	-1.0		1.0	dB
EXP _{OUT}	Expander error at +24.6dB output level ²	Input level = +12.3dB	-1.0		1.0	dB
EXP _{OUT}	Expander V _{OS}	No signal	-50.0		50.0	mV
EXP _{OUT}	Expander output DC shift	No signal to 0dB	-100		100	mV
	Timing capacitors compandor			2200		nF
THD	Total harmonic distortion					
	Compressor	1kHz, 0dB			1	%
	Expander	1kHz, 0dB			1	%
	NCAN _{OUT}	1kHz, Pin 2 open output level = 0dB				1
1kHz, Pin 2 open output level = +25dB					1	%
VOX _{OUT}	Sink current				0.5	mA
	Low level High level	Open collector I _L = 0.5mA		V _{CC}	0.4	V V
VOX _{CTL}	Input current	Low	-50		0	μA
		High	-10		+10	μA
	Input level	Low High	0 0.7V _{CC}		0.3V _{CC} V _{CC}	V V
HPDN	Input current	Low	-10		+10	μA
		High	-10		+10	μA
	Input level	Low High	0 0.7V _{CC}		0.3V _{CC} V _{CC}	V V
	Reference filter capacitor			10		μF

NOTE:

1. Measurements are relative to 0dB output.
2. Measurement is absolute and indicative of the output dynamic range capability.

Audio processor – companding, VOX and amplifier section

NE/SA5752

PHILIPS INTERNATIONAL

60E D ■ 7110826 0054586 275 ■ PHIN

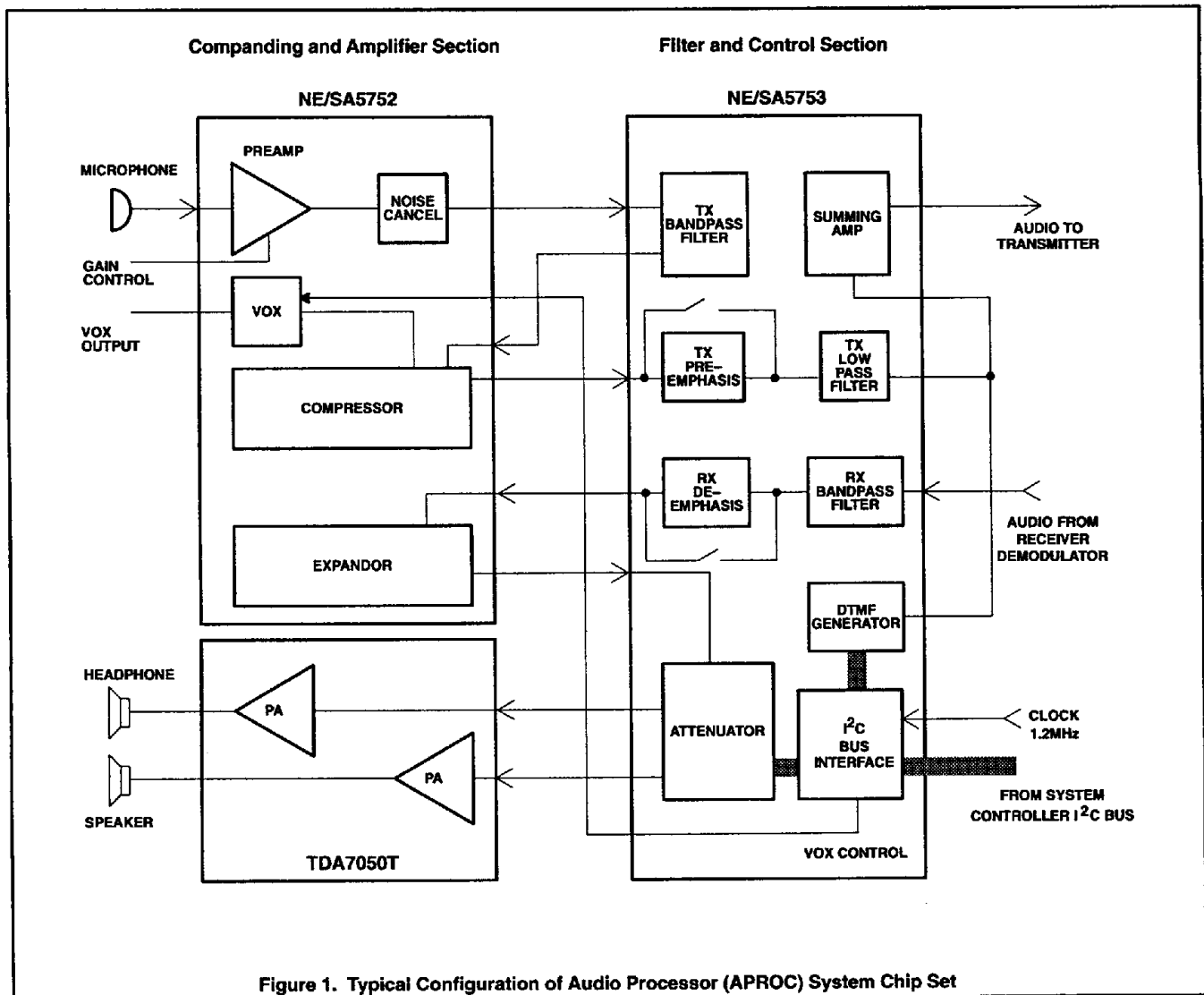

Figure 1. Typical Configuration of Audio Processor (APROC) System Chip Set

Audio processor – companding, VOX and amplifier section

NE/SA5752

PHILIPS INTERNATIONAL

60E D ■ 7110826 0054587 101 ■ PHIN

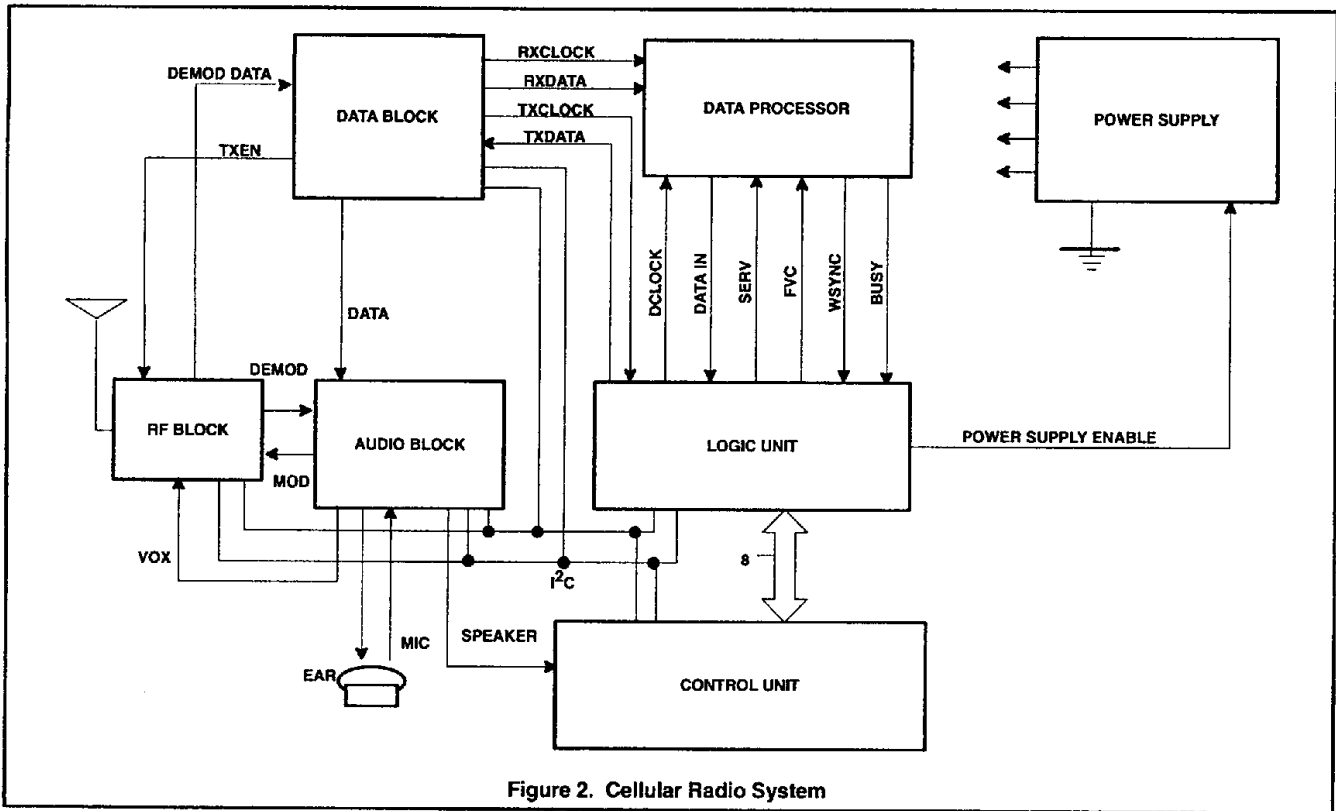

Figure 2. Cellular Radio System

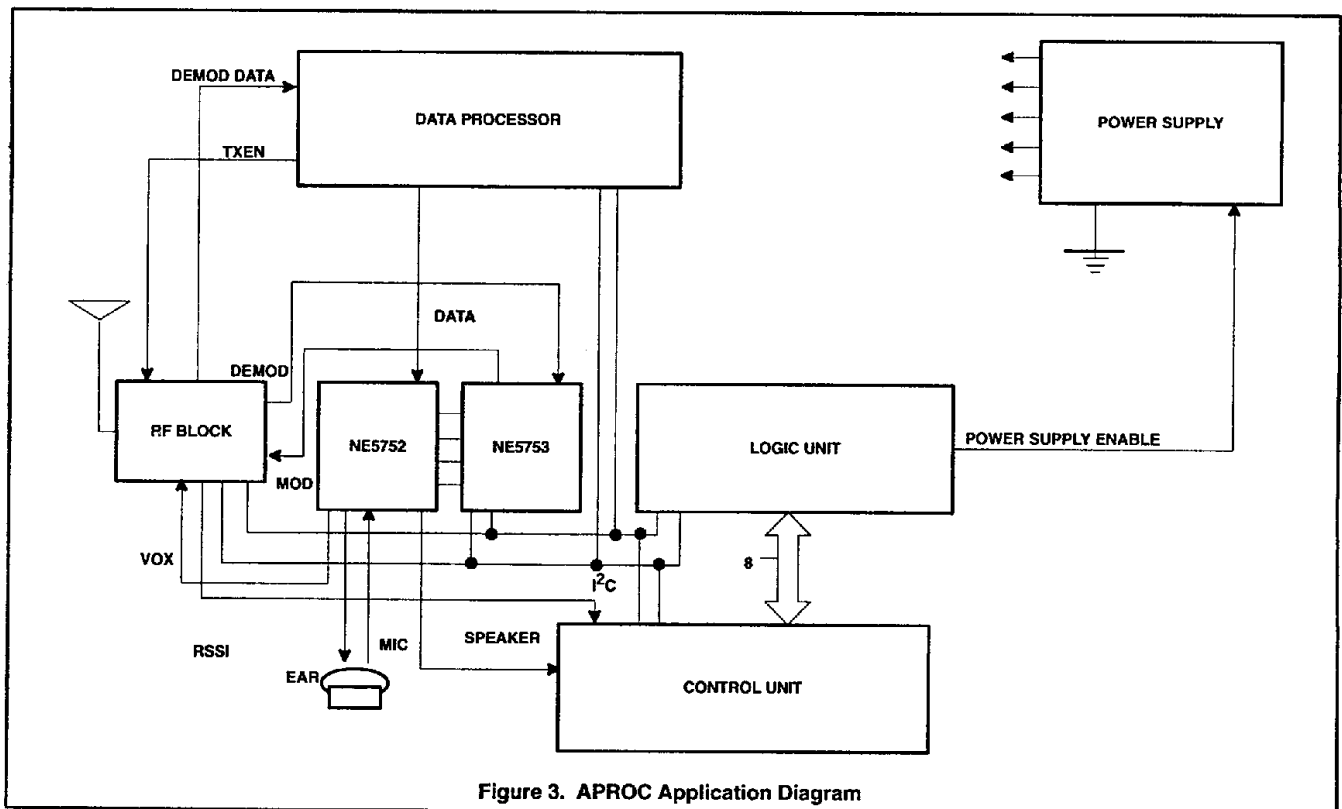

Figure 3. APROC Application Diagram

Audio processor – companding, VOX and amplifier section

NE/SA5752

PHILIPS INTERNATIONAL

60E D ■ 7110826 0054588 048 ■ PHIN

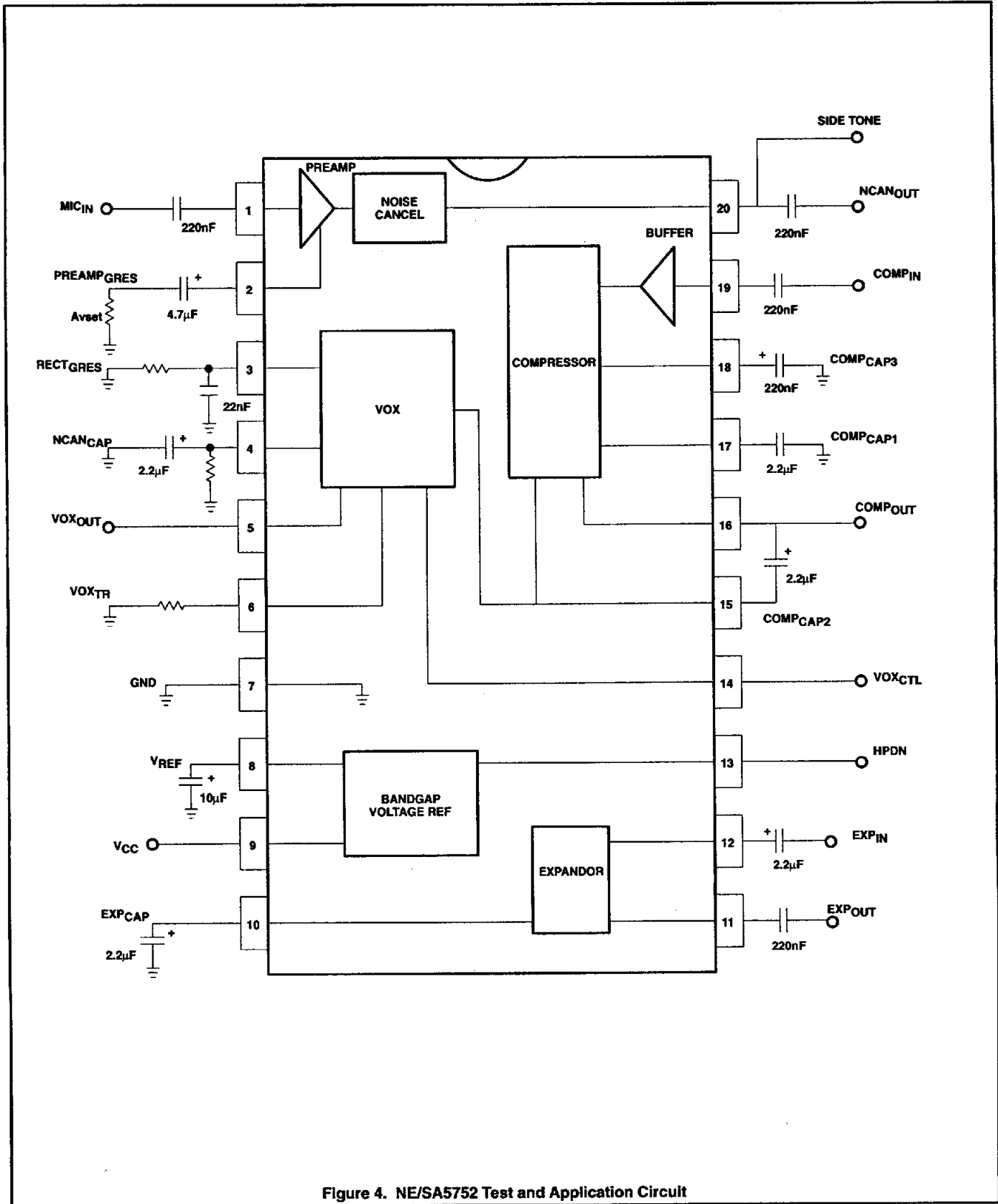

Figure 4. NE/SA5752 Test and Application Circuit

Audio processor – companding, VOX and amplifier section

NE/SA5752

PHILIPS INTERNATIONAL

60E D

7110826 0054589 T84 PHIN

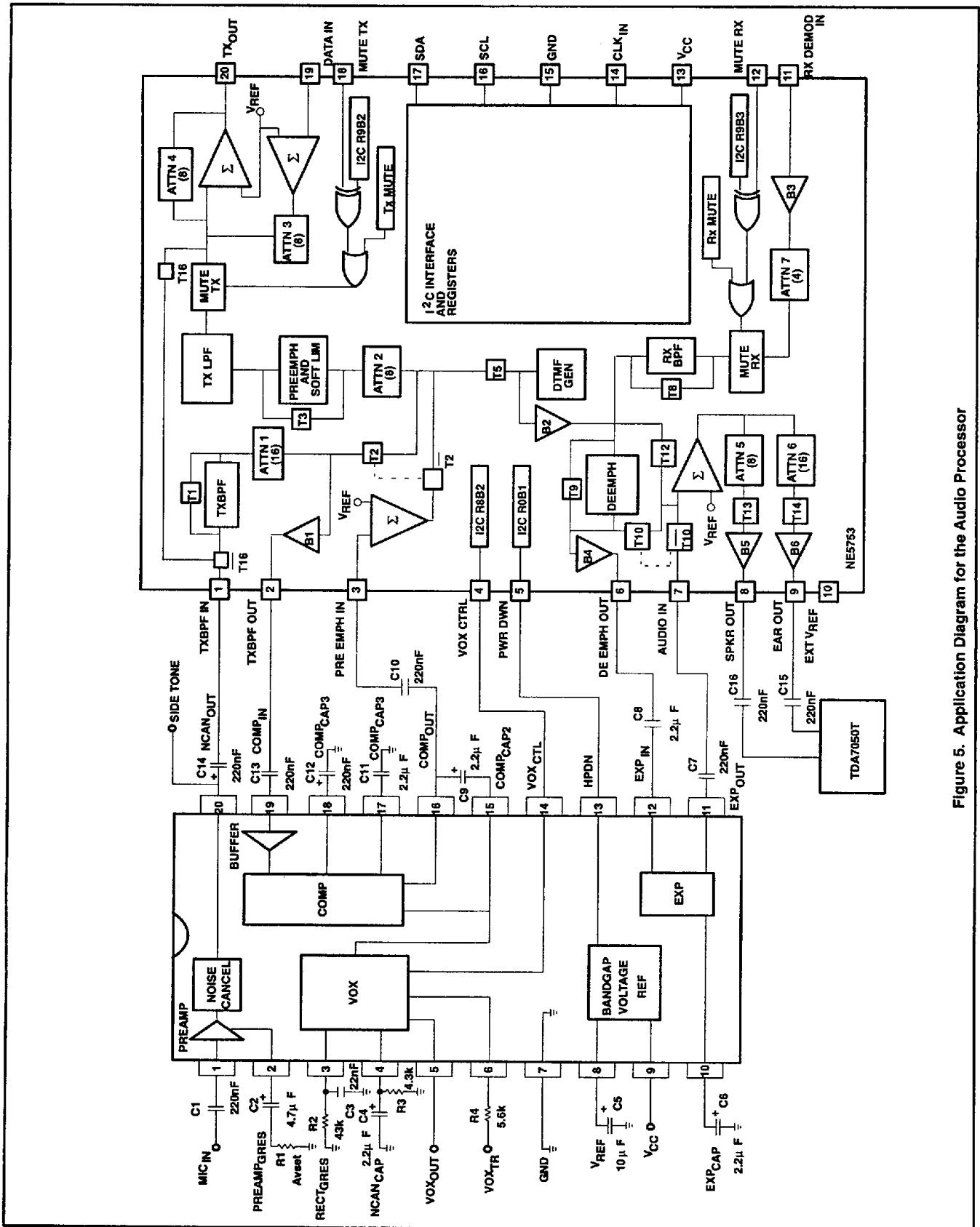

Figure 5. Application Diagram for the Audio Processor