

DATA SHEET

SA57003

Five-output composite voltage regulator

Product data
Supersedes data of 2001 Aug 01

2003 Oct 13

Five-output composite voltage regulator

SA57003

GENERAL DESCRIPTION

The SA57003 is a very low noise, low dropout voltage regulator with three independent preset outputs from 2.0 V to 5.0 V and two dependent outputs regulated from 2.82 V up to V_{OUT3} . The output current is the same for all three independent outputs 1, 2, 3 and each output is capable of supplying 200 mA. The other two dependent outputs 4, 5 are capable of supplying current up to 185 mA and 195 mA, respectively. Additionally, the SA57003 has an independent ON/OFF input pin for each output to allow individual subcircuits to be turned off when not needed, making the device very useful for applications where power conservation is important.

The independent output voltage regulators V_{OUT1} , V_{OUT2} , and V_{OUT3} have a common input voltage pin, V_{IN} . The dependent output voltage regulators, V_{OUT4} and V_{OUT5} have a common input voltage pin, V_{OUT3} .

The SA57003 regulator is offered in the TSSOP16 package.

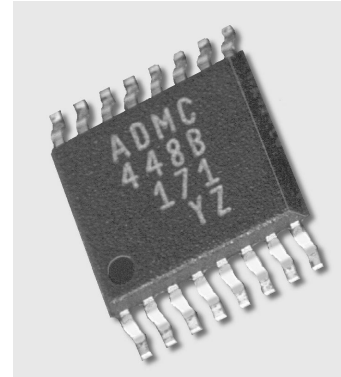

FEATURES

- V_{OUT} tolerance $\pm 3\%$ over temperature range $-40\text{ }^{\circ}\text{C}$ to $+85\text{ }^{\circ}\text{C}$
- ON/OFF input pin (logic-controlled shut-down) for each output
- Very low dropout voltage (0.15 V typical for Outputs 1, 2, 3 and 0.25 V for Outputs 4, 5)
- No load quiescent current of 170 μA
- Maximum input voltage of 12 V
- Internal current and thermal limit
- Supply voltage rejection: 60 dB (typical) @ $f = 1.0\text{ kHz}$
- Internal trimmed voltage reference

APPLICATIONS

- Mobile phones
- Video cameras
- Portable battery-powered telemetry equipment.

SIMPLIFIED SYSTEM DIAGRAM

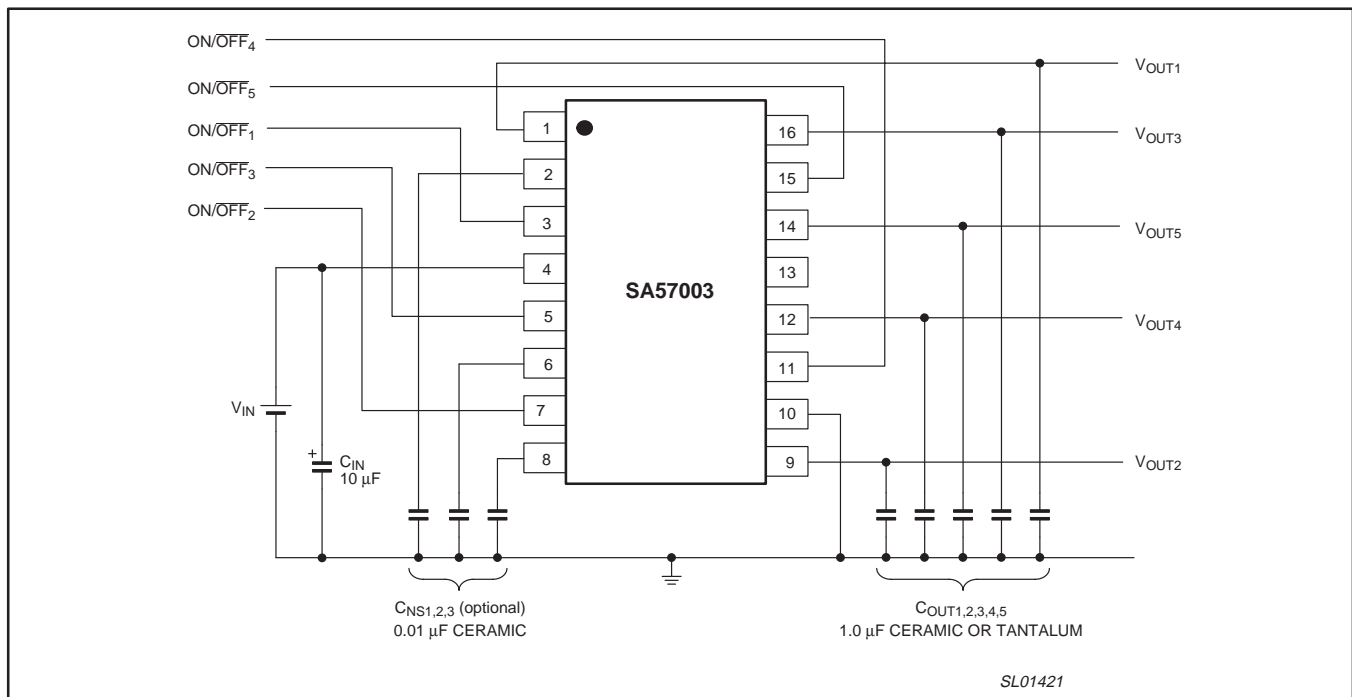

Figure 1. Simplified system diagram.

Five-output composite voltage regulator

SA57003

ORDERING INFORMATION

TYPE NUMBER	PACKAGE			TEMPERATURE RANGE
	NAME	DESCRIPTION	VERSION	
SA57003DH	TSSOP16	plastic thin shrink small outline package; 16 leads	SOP001	-40 to +85 °C

Part number marking

Each device is marked with three or four lines of alphanumeric codes. The first three letters of the top line designate the product. The fourth letter, represented by "x", is a date tracking code. The remaining lines are for manufacturing codes.

The first three letters, ADM, designate the product. The fourth letter, represented by 'x', is a date tracking code.

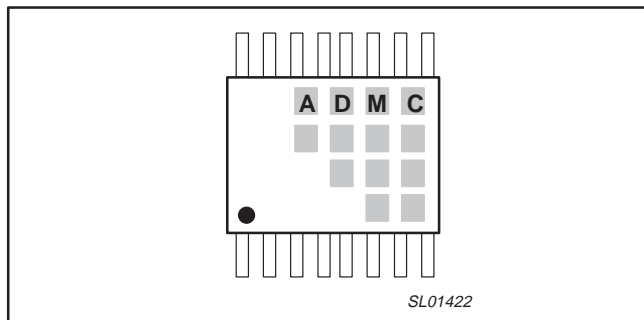

PIN CONFIGURATION

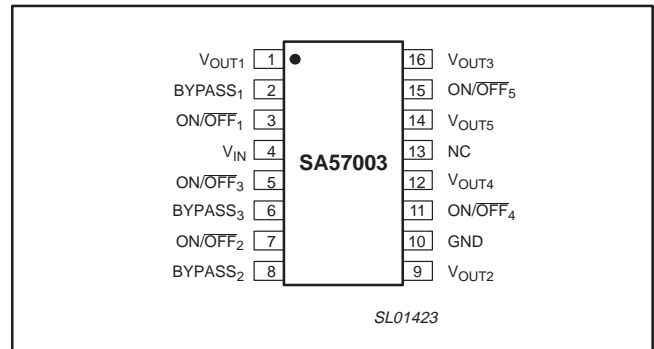

Figure 2. Pin configuration.

Five-output composite voltage regulator

SA57003

PIN DESCRIPTION

PIN	SYMBOL	DESCRIPTION	TERMINAL EQUIVALENT CIRCUIT
3, 5, 7, 11, 15	ON/OFF _n	On/Off control pins for the output pins. Connect to V _{IN} for always-on outputs.	<p>BIAS CIRCUIT</p> <p>ON/OFF_n</p> <p>R 300 kΩ</p> <p>R 400 kΩ</p> <p>SL01424</p>
2, 8, 6	NS ₁ , NS ₂ , NS ₃	Noise-decrease bypass capacitor pins.	<p>TO V_{OUT}</p> <p>POWER TRANSISTOR DRIVE CIRCUIT</p> <p>R</p> <p>NS_n</p> <p>C_{ns}</p> <p>SL01425</p>
1, 9, 16	V _{OUT1} , V _{OUT2} , V _{OUT3}	Voltage output.	<p>TO ERROR AMP</p> <p>POWER TRANSISTOR</p> <p>V_{OUT1,2,3}</p> <p>C_{OUT1,2,3}</p> <p>POWER TRANSISTOR DRIVE CIRCUIT</p> <p>SL01426</p>
12, 14	V _{OUT4} , V _{OUT5}	Voltage output. These two outputs are powered by the circuit that produced V _{OUT3} , and will be turned on an off with the V _{OUT3} output. They may be independently switched ON or OFF while V _{OUT3} is active.	<p>V_{OUT3}</p> <p>POWER TRANSISTOR</p> <p>V_{OUT4,5}</p> <p>C_{OUT4,5}</p> <p>POWER TRANSISTOR DRIVE CIRCUIT</p> <p>SL01427</p>
4	V _{IN}	Common input supply voltage for all regulators.	
10	GND	Common circuit ground pin for all regulators.	
13	N/C	No connection.	

Five-output composite voltage regulator

SA57003

MAXIMUM RATINGS

SYMBOL	PARAMETER	MIN.	MAX.	UNIT
V_{IN}	Input supply voltage	-0.3	12	V
T_{oper}	Operating ambient temperature range	-20	+75	°C
T_j	Operating junction temperature	-	t.b.d.	°C
T_{stg}	Storage temperature	-40	+125	°C
$I_{OUT1,2,3}$	Output currents; Note 1	-	200	mA
P_D	Power dissipation	-	400	mW
$R_{th(j-a)}$	Thermal resistance from junction to ambient	-	t.b.d.	°C/W
V_{ESD1}	ESD damage threshold (Human Body Model); Note 2	-	2000	V
V_{ESD2}	ESD damage threshold (Machine Model); Note 3	-	200	V
T_{solder}	Soldering temperature; Note 4	-	230	°C

NOTES:

1. Maximum current capability of one circuit ($V_{OUT1,2,3}$).
2. Performed in accordance with Human Body Model ($C_{Zap} = 100$ pF, $R_{Zap} = 1500$ Ω).
3. Performed in accordance with Machine Model ($C_{Zap} = 100$ pF, $R_{Zap} = 0$ Ω).
4. 60 second maximum exposure for SMD Reflow temperatures above 183 °C.

Five-output composite voltage regulator

SA57003

ELECTRICAL CHARACTERISTICS

$V_{IN} = 4.0$ V, $C_{IN} = 10$ μ F, $C_{OUT1,2,3} = 4.7$ μ F with 1.0 Ω series resistor, $C_{OUT4,5} = 1.0$ μ F, $C_{NS1,2,3} = 0.01$ μ F, $T_{amb} = 25$ $^{\circ}$ C, unless otherwise noted. See Test Circuit 1 for test configuration for DC parameters.

SYMBOL	PARAMETER	CONDITIONS	MIN.	TYP.	MAX.	UNIT
I_{INS}	Supply current (OFF)	$V_{ON/OFF1} = V_{ON/OFF2} = V_{ON/OFF3} = 0$ V	–	0	3	μ A
$I_{IN1,2,3}$	Supply current 1,2,3	$V_{ON/OFF1} = 3.0$ V; $V_{ON/OFF2} = V_{ON/OFF3} = V_{ON/OFF4,5} = 0$ V	–	170	350	μ A
$I_{q(standby)}$	Standby quiescent current	ON/OFF _{1,2,3,4,5} = 0 V $I_{OUT1,2,3,4,5} = 0$ mA	–	0	3.0	mA
$I_{GND(operating)}$	Operating ground current ¹	ON/OFF ₁ = 3.0 V, ON/OFF _{2,3,4,5} = 0 V; ON/OFF ₂ = 3.0 V, ON/OFF _{1,3,4,5} = 0 V; ON/OFF ₃ = 3.0 V, ON/OFF _{1,2,4,5} = 0 V	–	170	350	μ A
I_{LIM}	Output current limit ($I_{OUT1,2,3}$)		200	240	–	mA
ON/OFF						
V_{OFF}	ON/OFF LOW threshold voltage		–	–	0.4	V
V_{ON}	ON/OFF HIGH threshold voltage		1.6	–	–	V
$I_{ON/OFF}$	Terminal current	$V_{ON/OFF} - 1.6$ V	–	–	10	mA
V_{OUT1}						
V_{OUT1}	Output voltage 1	$I_{OUT1} = 30$ mA	2.42	2.50	2.58	V
V_{DMIN1}	Dropout voltage ²	$I_{OUT1} = 30$ mA; $V_{IN} = 2.3$ V	1.1	1.5	0.2	V
ΔV_{LO1}	Load regulation	$I_{OUT1} = 0 - 100$ mA	–	30	60	mV
ΔV_{LI1}	Line regulation	$I_{OUT1} = 30$ mA; $V_{IN} = 4.0 - 8.0$ V	–	10	20	mV
$\Delta V_{O1}/\Delta T$	V_{OUT} temperature coefficient	$-20 \leq T_{amb} \leq 75$ $^{\circ}$ C; $I_{OUT1} = 30$ mA	–	± 100	–	μ V/ $^{\circ}$ C
RR_1	Ripple rejection	$f = 120$ Hz; $I_{OUT1} = 30$ mA; $V_{RIPPLE} = 1.0$ V _{P-P}	50	60	–	dB
V_{N1}	Output noise voltage	$f = 10$ Hz – 10 kHz; $I_{OUT1} = 30$ mA; $C_{NS1} = 0.01$ μ F	–	–	–	μ V _{RMS}
t_{DH1}	Output delay time	$I_{OUT1} = 30$ mA; $V_{ON/OFF1} = 0 \rightarrow 4$ V	–	0.04	0.8	ms
V_{OUT2}						
V_{OUT2}	Output voltage 2	$I_{OUT2} = 30$ mA	2.42	2.80	2.88	V
V_{DMIN2}	Dropout voltage ²	$I_{OUT2} = 30$ mA; $V_{IN} = 2.3$ V	1.1	1.5	0.2	V
ΔV_{LO2}	Load regulation	$I_{OUT2} = 0 - 100$ mA	–	30	60	mV
ΔV_{LI2}	Line regulation	$I_{OUT2} = 30$ mA; $V_{IN} = 4.0 - 8.0$ V	–	10	20	mV
$\Delta V_{O2}/\Delta T$	V_{OUT} temperature coefficient	$-20 \leq T_{amb} \leq 75$ $^{\circ}$ C; $I_{OUT2} = 30$ mA	–	± 100	–	μ V/ $^{\circ}$ C
RR_2	Ripple rejection	$f = 120$ Hz; $I_{OUT2} = 30$ mA; $V_{RIPPLE} = 1.0$ V _{P-P}	50	60	–	dB
V_{N2}	Output noise voltage	$f = 10$ Hz – 10 kHz; $I_{OUT2} = 30$ mA; $C_{NS2} = 0.01$ μ F	–	–	–	μ V _{RMS}
t_{DH2}	Output delay time	$I_{OUT2} = 30$ mA; $V_{ON/OFF2} = 0 \rightarrow 4$ V	–	0.04	0.8	ms
V_{OUT3}						
V_{OUT3}	Output voltage 3	$I_{OUT3} = 80$ mA	2.92	3.00	3.08	V
V_{DMIN3}	Dropout voltage ²	$I_{OUT3} = 80$ mA; $V_{IN} = 2.3$ V	–	–	0.3	V
ΔV_{LO3}	Load regulation	$I_{OUT3} = 0 - 100$ mA	–	–	60	mV
ΔV_{LI3}	Line regulation	$I_{OUT3} = 30$ mA; $V_{IN} = 4.0 - 8.0$ V	–	–	20	mV
$\Delta V_{O3}/\Delta T$	V_{OUT} temperature coefficient	$-20 \leq T_{amb} \leq 75$ $^{\circ}$ C; $I_{OUT3} = 30$ mA	–	± 100	–	μ V/ $^{\circ}$ C
RR_3	Ripple rejection	$f = 120$ Hz; $I_{OUT3} = 30$ mA; $V_{RIPPLE} = 1.0$ V _{P-P}	50	60	–	dB
V_{N3}	Output noise voltage	$f = 10$ Hz – 10 kHz; $I_{OUT3} = 30$ mA; $C_{NS3} = 0.01$ μ F	–	30	60	μ V _{RMS}
t_{DH3}	Output delay time	$I_{OUT3} = 30$ mA; $V_{ON/OFF3} = 0 \rightarrow 4$ V	–	0.04	0.8	ms

Five-output composite voltage regulator

SA57003

SYMBOL	PARAMETER	CONDITIONS	MIN.	TYP.	MAX.	UNIT
V_{OUT4}						
V _{OUT4}	Output voltage 4	I _{OUT3} = I _{OUT4} = 20 mA; I _{OUT5} = 40 mA	2.82	–	V _{OUT3}	V
I _{O4}	Maximum output current	V _{OUT4} = 2.72 V; I _{OUT3} = I _{OUT5} = 0 mA	50	–	185	mA
t _{DH4}	Output delay time	I _{OUT4} = 20 mA; C _{OUT4} = 1 μF; V _{ON/OFF4} = 0 → 4.0 V	–	0.02	0.1	ms
I _{GND4}	Ground current	I _{OUT4} = 20 mA; V _{OUT3} = 3.0 V	–	0.5	0.8	mA
V_{OUT5}						
V _{OUT5}	Output voltage 4	I _{OUT3} = I _{OUT4} = 20 mA; I _{OUT5} = 40 mA	2.82	–	V _{OUT3}	V
I _{O5}	Maximum output current	V _{OUT5} = 2.72 V; I _{OUT3} = I _{OUT4} = 0 mA	80	–	195	mA
t _{DH5}	Output delay time	I _{OUT5} = 40 mA; C _{OUT4} = 1 μF; V _{ON/OFF5} = 0 → 4.0 V	–	0.02	0.1	ms
I _{GND5}	Ground current	I _{OUT5} = 40 mA; V _{OUT3} = 3.0 V	–	0.5	0.8	mA

NOTES:

- Individual operating ground currents for regulators 1, 2, and 3 with corresponding ON/OFF pins (ON/OFF_{1,2,3}) connected to 3.0 V and outputs open (I_{OUT1,2,3} = 0 mA). Regulators 1, 2, and 3 are the same.
- Dropout Voltage is a measure of the minimum input/output differential voltage at the specified output current.

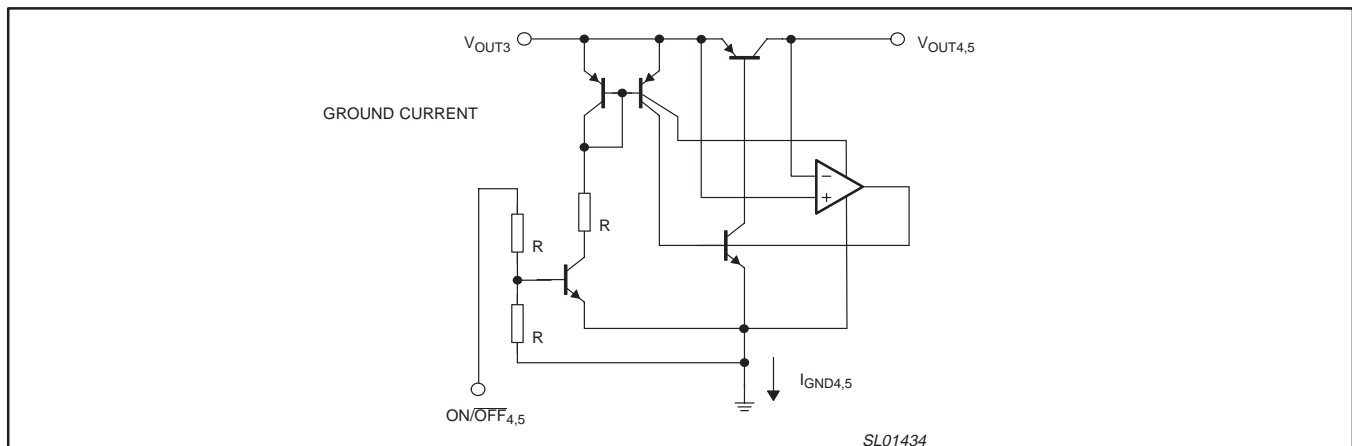

Figure 3. Ground current for V_{OUT4} and V_{OUT5}.

Five-output composite voltage regulator

SA57003

TYPICAL PERFORMANCE CURVES

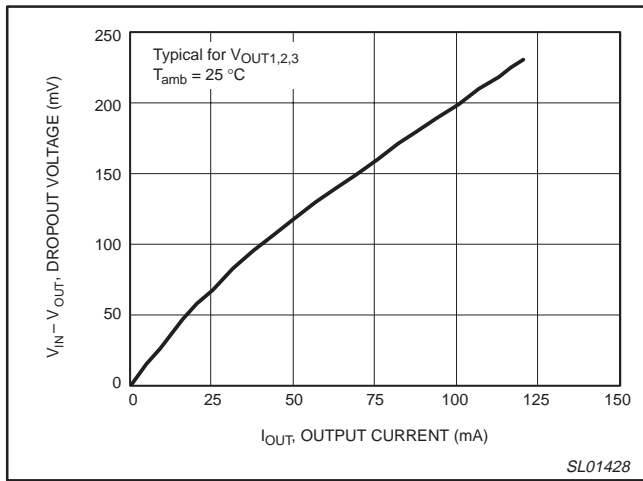

Figure 4. Dropout voltage versus output current.

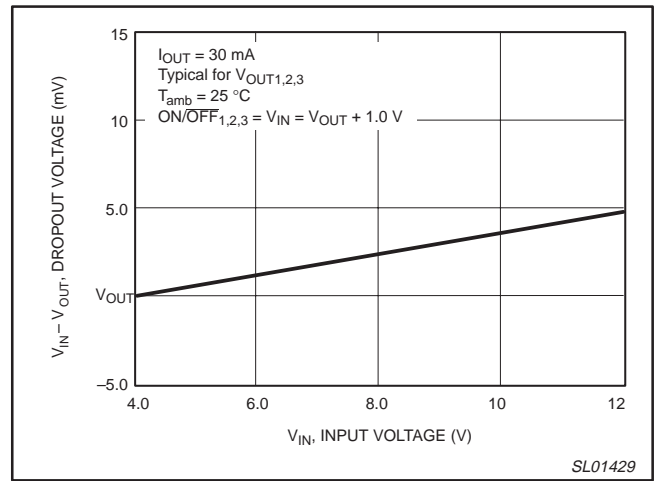

Figure 5. Normalized line regulation versus input voltage.

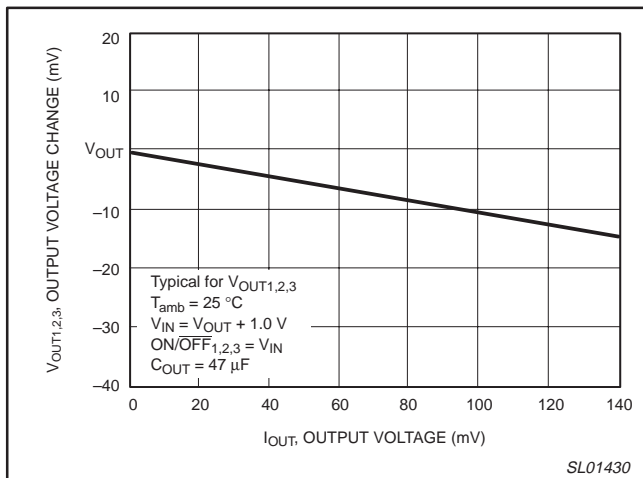

Figure 6. Normalized load regulation.

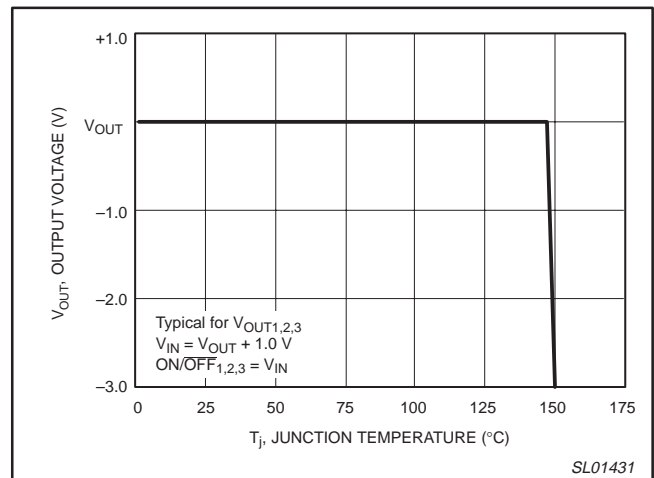

Figure 7. Thermal shutdown.

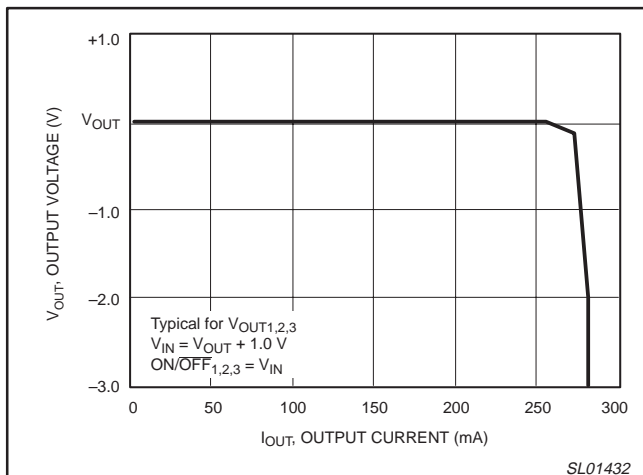

Figure 8. Typical output current limit.

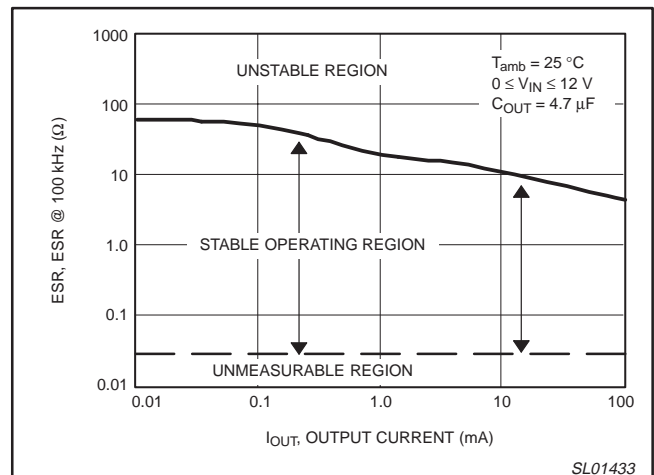

Figure 9. ESR stability versus output current.

Five-output composite voltage regulator

SA57003

TECHNICAL DESCRIPTION

The SA57003 is a monolithic composite five-output regulator developed to power the RF sections of mobile telephones. It contains three independent full-featured voltage regulator circuits. Each regulator circuit incorporates individual feedback error amplifiers for output voltage regulation, output On/Off Control, Noise Bypass Pin, Current Limiting, and Thermal Shutdown. The Noise Bypass Pins provide the option of externally bypassing an internal voltage reference node for enhanced noise reduction.

The output of one of the three regulator circuits, in addition to being pinned out, feeds two dependent switched output regulators. Both switched output regulators incorporate individual feedback error amplifiers for output voltage regulation but have no thermal shutdown or current limiting feature.

The three full-featured regulators have typical dropout voltages of 200 mV at 30 mA of output current. The two switched outputs have a minimum current capacity of 80 mA each.

Each independent regulator in the SA57003 is a series pass regulator incorporating a bandgap reference, two feedback amplifiers, thermal shutdown circuit, and output current limiting. See the device block diagram shown in Figure 10 and the equivalent circuit in Figure 11. Both feedback amplifiers are referenced to the same bandgap reference. A PNP transistor is used in the device's output and serves as a series pass element. The output PNP pass transistor incorporates a dual collector. The first feedback amplifier monitors the first collector's output voltage through the use of a voltage divider network fed from the output. The second collector monitors the output current and produces a small output current

proportional to that current delivered to the output. This small proportional current is used to generate a second feedback voltage fed to the second feedback amplifier to fold back the output current to a safe level in the event of an output short. Both feedback amplifiers act on the same control node to control the PNP pass transistor. Dual path output monitoring in this manner maintains a constant output voltage while adding the feature enhancement of output current limiting.

Operating stability of the SA57003 linear regulator is determined by start-up delay, transient response to loading, and stability of the feedback loop. The SA57003 has a fast transient loop response. No built-in delay is incorporated.

Capacitors play an important part in compensating the regulator's output. A 4.7 μ F aluminum electrolytic capacitor is recommended for most applications. This consideration is made primarily on a basis of minimal cost with good performance.

A tantalum capacitor could also be used. Tantalum capacitors have the advantage of being smaller size than electrolytic capacitors of the same value of capacitance. Tantalum capacitors are also not prone to dry-out. The electrolyte used in electrolytic capacitors tends to dry-out with time causing degradation in capacitance value. Avoid using low ESR film or ceramic capacitors to avoid instability problems.

Keep in mind that the output capacitor tries to supply any instantaneous increase in load current. Using higher values of capacitance will enhance transient load performance as well as stability. Lowering the ESR of the capacitors will also improve the transient response to load current changes but at the expense of stability.

Five-output composite voltage regulator

SA57003

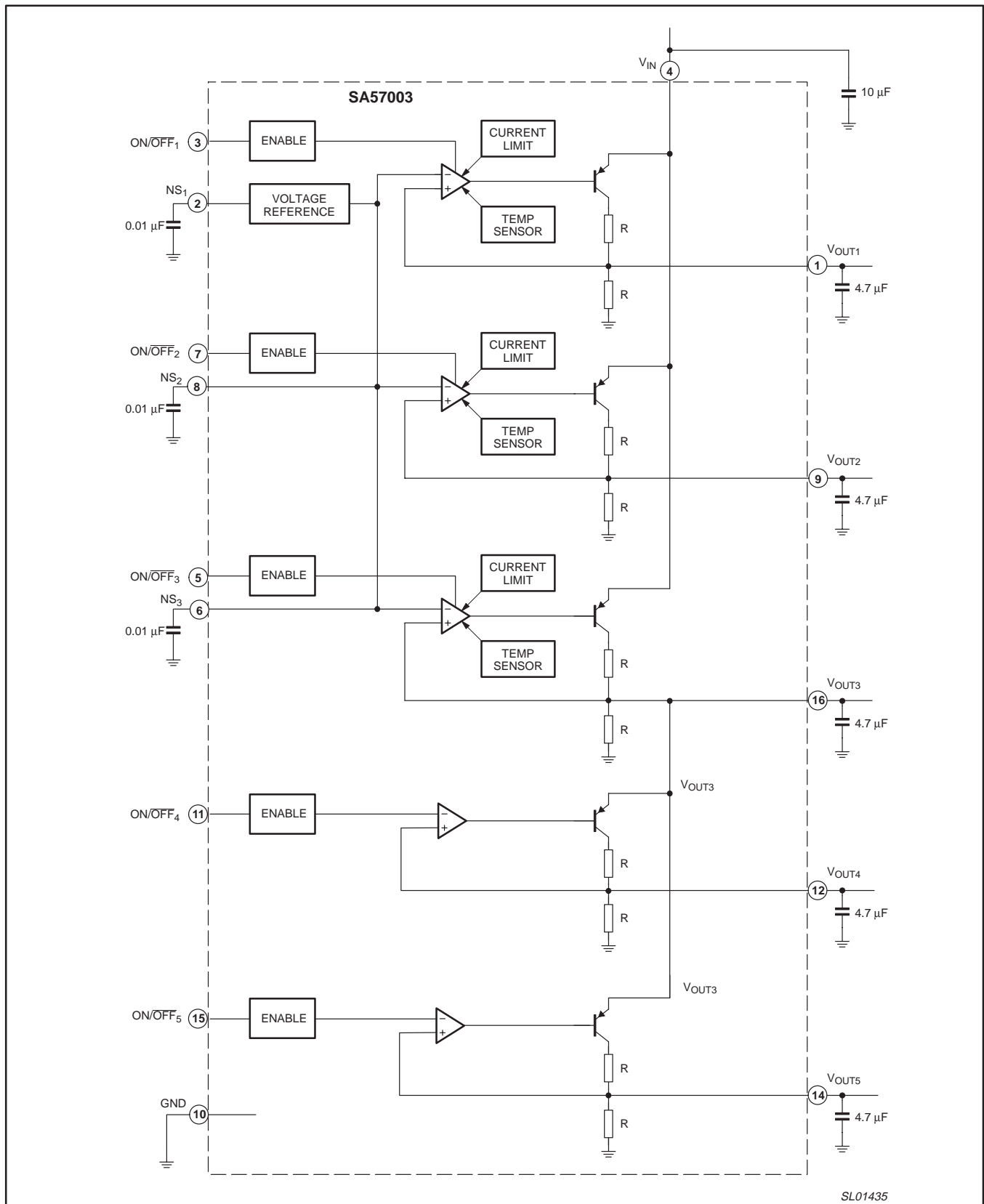

Figure 10. Simplified block diagram.

Five-output composite voltage regulator

SA57003

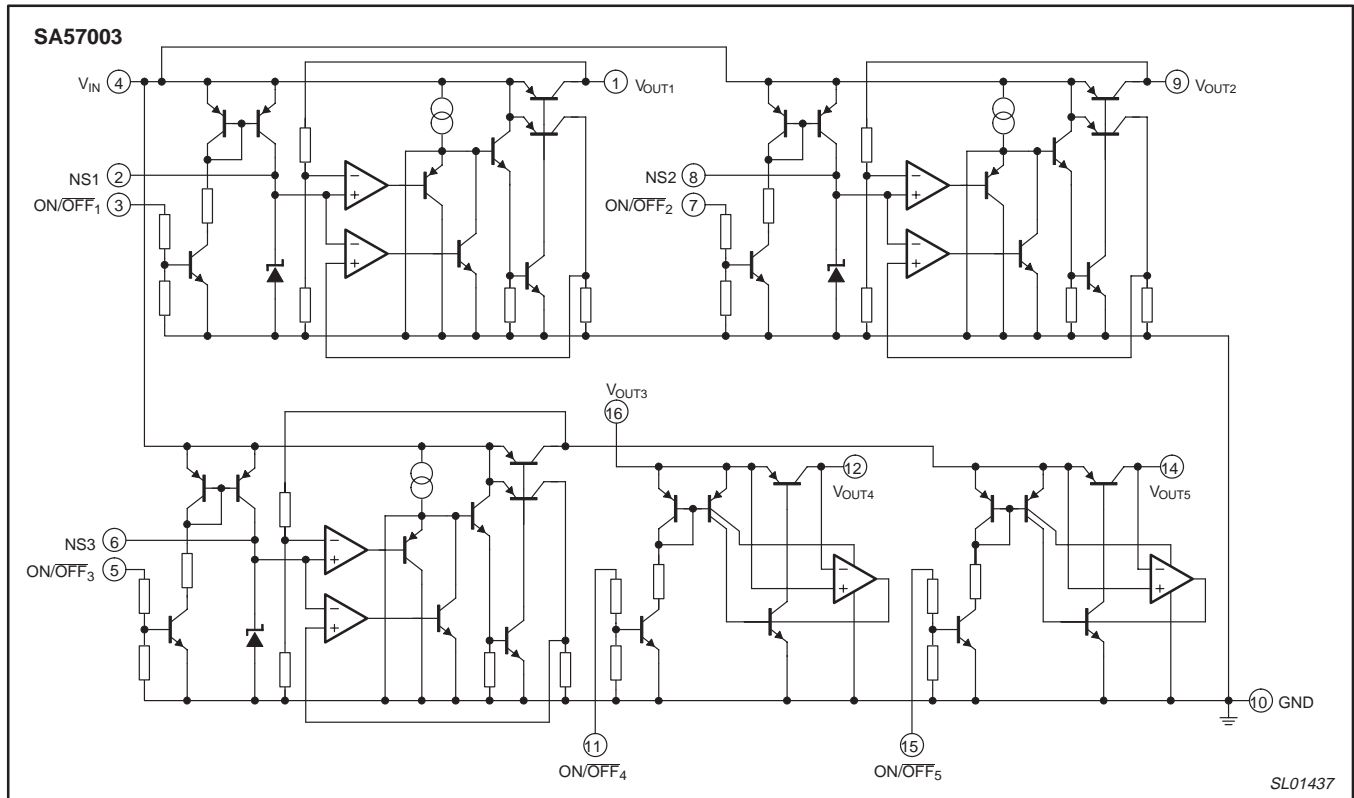

Figure 11. Equivalent circuit.

Five-output composite voltage regulator

SA57003

APPLICATION INFORMATION

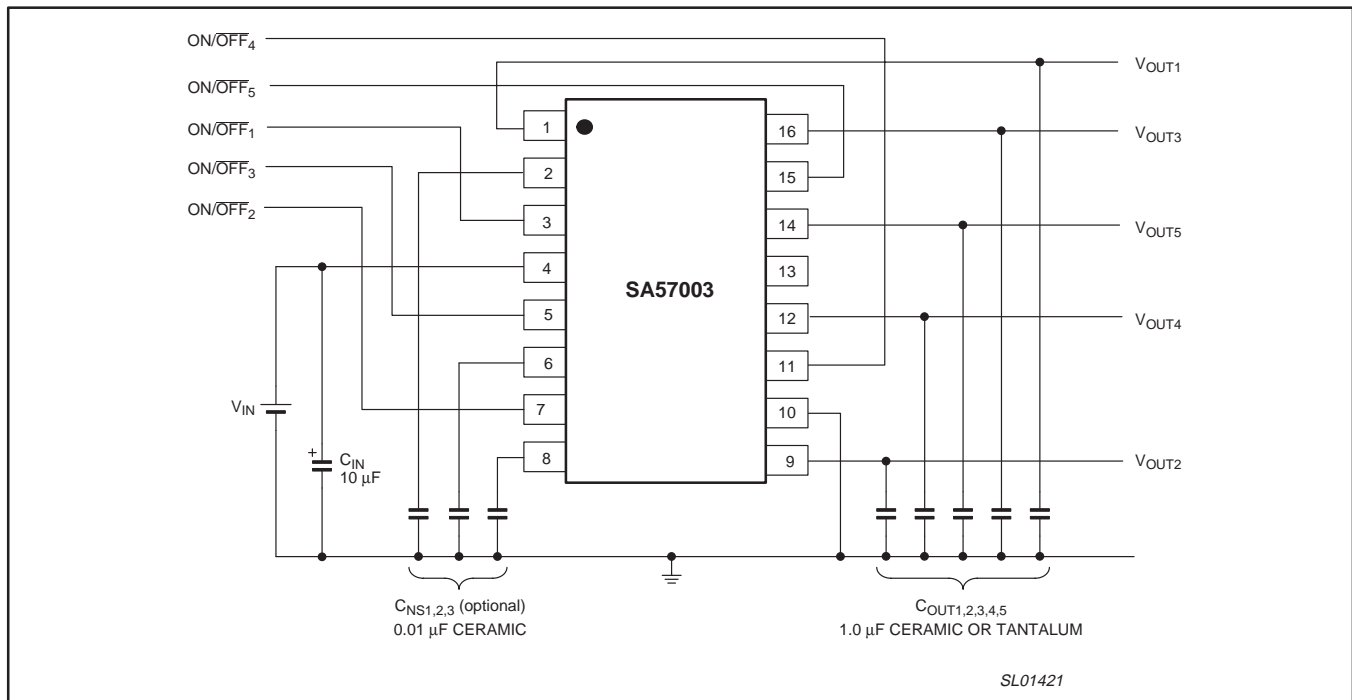

Figure 12. Typical application circuit.

Stability Factors: Capacitance and ESR

The operating stability of linear regulators is determined by start-up delay, transient response to load currents, and stability of the feedback loop. The SA57003 has a fast transient loop response, with no built-in delay.

Keep in mind that the output capacitor tries to supply any instantaneous increase in load current from its stored energy. Using higher values of capacitance will enhance transient load performance as well as stability. Lowering the ESR of the capacitors will also improve the transient response to load current changes, but it will decrease stability.

Power dissipation factors

The thermal performance of linear regulators depends on the following parameters:

- Maximum junction temperature (T_j) in °C
- Maximum ambient temperature (T_{amb}) in °C
- Power dissipation capability of the package in Watts (P_D)
- Junction-to-ambient thermal resistance in °C/W

The Maximum Junction Temperature and Maximum Power Dissipation are both determined by the manufacturer's process and device's design. For the most part the ambient temperature is under the control of the user. The Maximum Ambient Temperature depends on the process used by the manufacturer. The package type and manufacturer's process determines Junction-to-Ambient Thermal Resistance.

These parameters are related to each other as shown in the following equation:

$$T_j = T_{amb} + (P_D \times R_{th(j-a)})$$

The term $(P_D \times R_{th(j-a)})$ represents the temperature rise from the ambient to the internal junction of the device.

Power dissipation calculations

A regulator's maximum power dissipation can be determined by using the following equation:

$$P_{D(max)} = V_{IN(max)}I_G + [V_{IN(max)} - V_{OUT(min)}] I_{OUT(max)}$$

where:

- $V_{IN(max)}$ is the maximum input voltage
- I_G is the maximum Ground Current at maximum output current
- $V_{OUT(min)}$ is the minimum output voltage
- $I_{OUT(max)}$ is the maximum output current

$(V_{IN(max)}I_G)$ represents heat generated in the device due to internal circuit biasing, leakage, etc. $[V_{IN(max)} - V_{OUT(min)}]$ is the input-to-output voltage drop across the device due to the $I_{OUT(max)}$ current. When multiplied by $I_{OUT(max)}$, this represents heat generated in the device due to the output load current.

Heat dissipation factors

The SA57003 device should not be operated under conditions that would cause a junction temperature of 150 °C to be generated because the thermal shutdown protection circuit will shut down the device at or near this temperature.

Heat generated within the device is removed to the surrounding environment by radiation or conduction along several paths. In general, radiated heat is dissipated directly into the surrounding ambient from the chip package and leads. Conducted heat flows through an intermediate material, such as the leads or thermal grease, to circuit board traces and heat sinks in direct contact with the device's package or leads. The circuit board then radiates this heat to the ambient. For this reason, adequate airflow over the device and the circuit board is important.

The TSSOP16 package is too small to easily use external heat sinks to increase the surface area and enhance the dissipation of

Five-output composite voltage regulator

SA57003

generated heat. Heat dissipation must depend primarily on radiated heat into the surrounding environment and the heat flow through the leads into the printed circuit board. Some improvement can be realized by allowing additional exposed copper on the circuit board near the device to serve as heat absorbers and dissipaters for the device.

The overall thermal resistance from junction to the surrounding ambient of the package ($R_{th(j-a)}$) is made up of three series elements and can be thought of as the total resistance of a series electrical circuit. These elements are:

$$\begin{aligned} R_{th(j-c)} &= \text{Thermal resistance from Junction-to-Case} \\ R_{th(c-s)} &= \text{Thermal resistance from Case-to-heat Sink} \\ R_{th(s-a)} &= \text{Thermal resistance from heat Sink-to-Ambient} \end{aligned}$$

$R_{th(j-a)}$ is based primarily on the package type and the size of the silicon chip used in the device. The composition of package materials plays an important part. High heat conductivity materials produce reduced Junction-to-Case resistances.

$R_{th(c-s)}$ value is based on the package type, heat sink interface, and contact area of the device to the heat sink. The use of thermal grease or an insulator will increase the transfer of heat from the case to the heat sink.

$R_{th(s-a)}$, which is thermal resistance from heat sink to the ambient, is based on heat sink emissivity and airflow over the heat sink to carry the heat away. The heat sink to ambient heat flow is dependent on the ability of the surrounding ambient media to absorb the heat.

The total $R_{th(j-a)}$ thermal resistance is expressed as:

$$R_{th(j-a)} = R_{th(j-c)} + R_{th(c-s)} + R_{th(s-a)}$$

The maximum power that a given package can handle is given by:

$$P_D = \frac{T_{j(max)} - T_{amb}}{R_{th(j-a)}}$$

DEFINITIONS

Line regulation is the change in output voltage caused by a change in input line voltage. This parameter is measured using pulse measurement techniques or under conditions of low power dissipation so as to not significantly upset the thermal dynamics of the device during test.

Load regulation is the change in output voltage caused by a change in output load current for a constant device temperature.

Quiescent current is that current which flows to the ground pin of the device when the device is operated with no load.

Ground current is that current which flows to the ground pin of the device when the device is operated with output current flowing due to an applied load. It is the measurement difference of input current minus the output current.

Dropout voltage is the input/output differential at which the regulator output no longer maintains regulation against further reductions in input voltage. Measured when the output drops 100 mV below its nominal value (which is measured at 1.0 V differential input/output), dropout voltage is affected by junction temperature, load current and minimum input supply requirements.

Output noise voltage is the integrated output noise voltage (RMS AC) specified over a frequency range and expressed in nV/kHz or V_{rms} . It is measured at the output, with a constant load and no input ripple.

Current limiting is internal device circuitry incorporated to limit the output current of the device. This feature is incorporated in the device to protect the device against output over current conditions or output shorts to ground.

Thermal shutdown is internal device circuitry incorporated in the device to shut down the device when the chip temperature reaches a specified temperature. This feature protects the device from excessive operating temperatures that would otherwise be catastrophic to the device. Over heating can be created by accidental output shorts.

Maximum power dissipation is the maximum total dissipation for which the regulator will operate within specifications.

Five-output composite voltage regulator

SA57003

TEST CIRCUITS

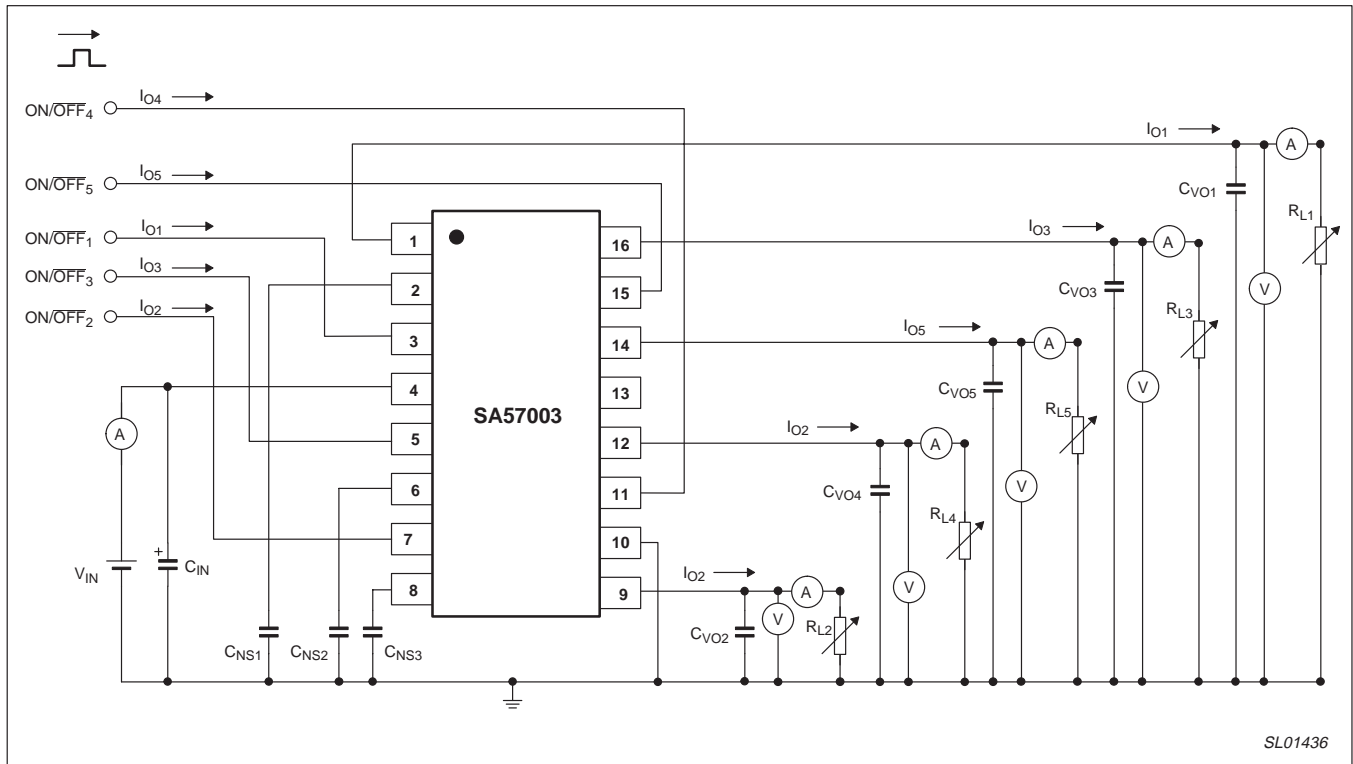

Figure 13. Test circuit 1.

PACKING METHOD

The SA57003 is packed in reels, as shown in Figure 14.

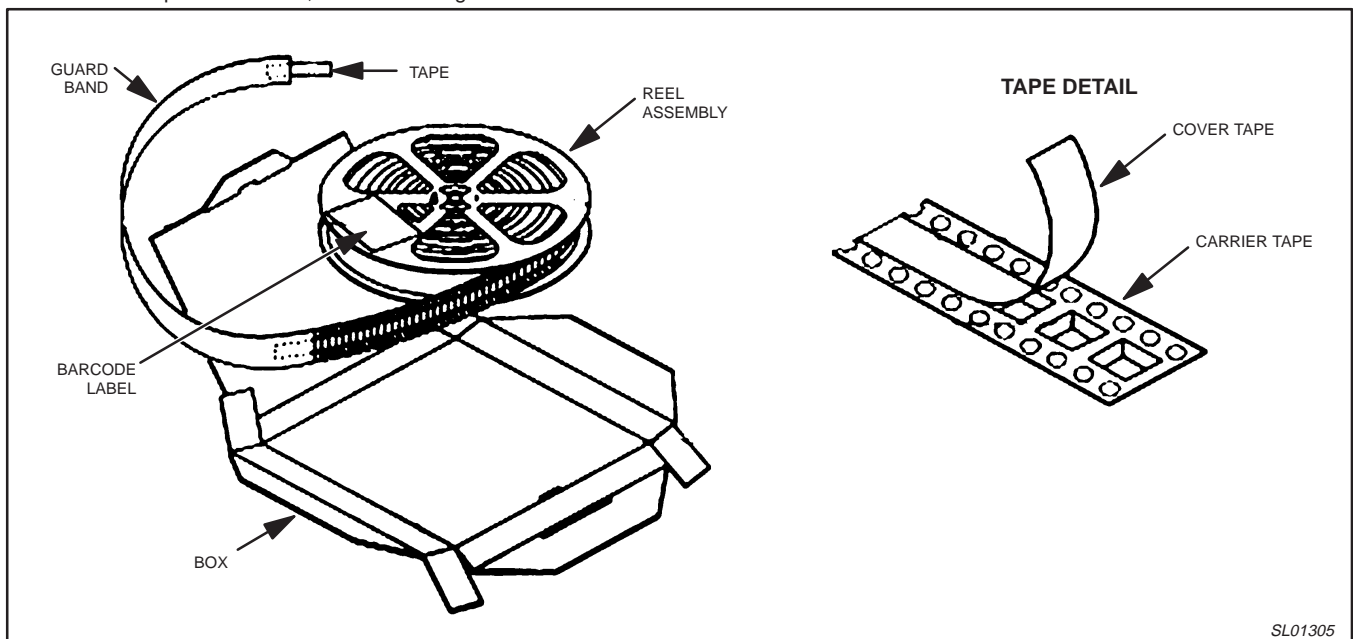

Figure 14. Tape and reel packing method

Five-output composite voltage regulator

SA57003

TSSOP16: plastic thin shrink small outline package; 16 leads; body width 4.4 mm

SOP001

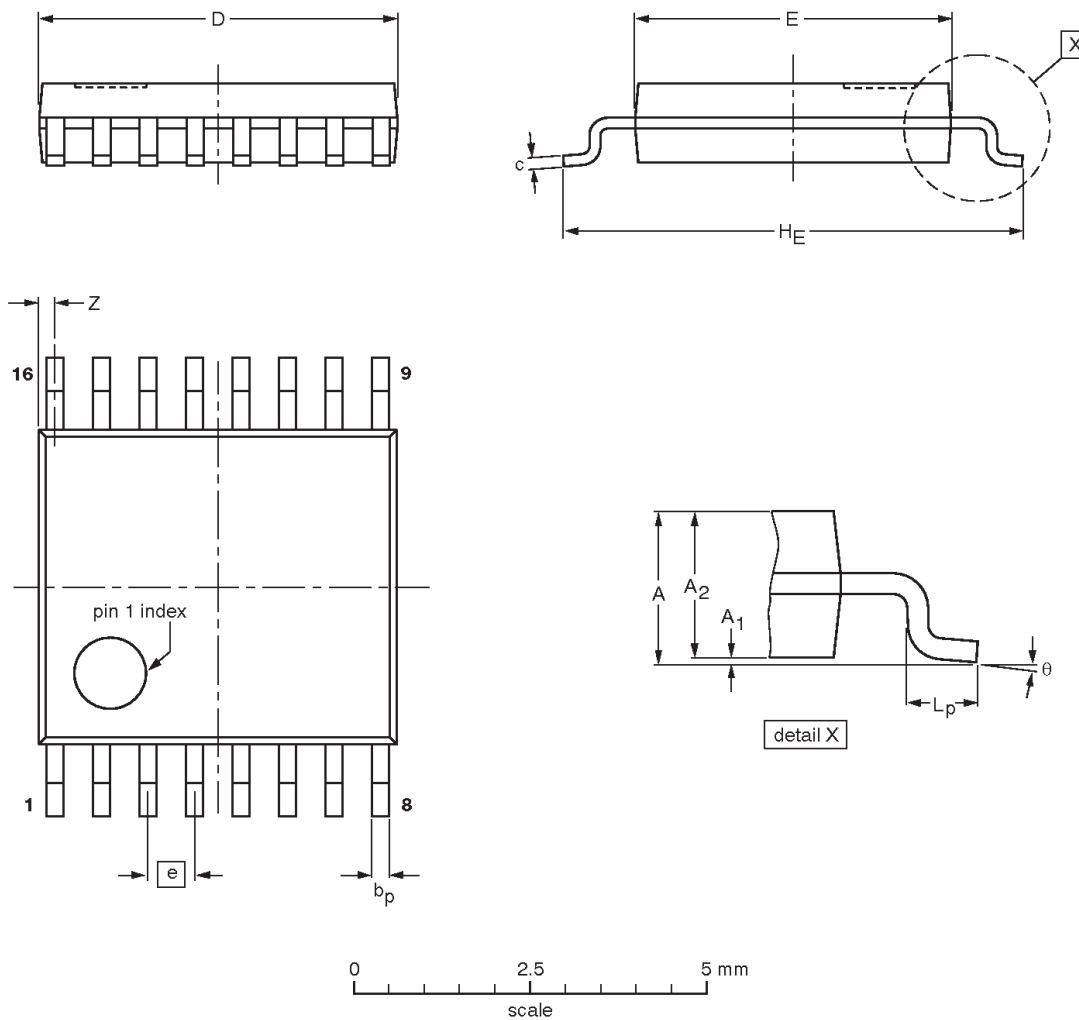

DIMENSIONS (mm are the original dimensions)

UNIT	A _{max}	A ₁	A ₂	b _p	c	D ⁽¹⁾	E ⁽²⁾	e	H _E	L _p	Z _{max.}	θ
mm	1.2	0.15 0.05	1.05	0.28 0.20	0.127	5.1 4.9	4.5 4.3	0.65	6.6 6.2	0.7 0.5	0.475	10° 0°

Notes

1. Plastic or metal protrusions of 0.15 mm maximum per side are not included.
2. Plastic or metal protrusions of 0.25 mm maximum per side are not included.

OUTLINE VERSION	REFERENCES				EUROPEAN PROJECTION	ISSUE DATE
	IEC	JEDEC	JEITA			
SOP001		MO-153				03-10-07

Five-output composite voltage regulator

SA57003

REVISION HISTORY

Rev	Date	Description
_2	20031013	Product data (9397 750 12114). ECN 853-2275 30325 of 09 September 2003. Modifications: <ul style="list-style-type: none"> • Change package version to SOP001 in Ordering information and Package outline sections.
_1	20010801	Product data (9397 750 08711). ECN 853-2275 26807 of 01 August 2001.

Data sheet status

Level	Data sheet status ^[1]	Product status ^{[2] [3]}	Definitions
I	Objective data	Development	This data sheet contains data from the objective specification for product development. Philips Semiconductors reserves the right to change the specification in any manner without notice.
II	Preliminary data	Qualification	This data sheet contains data from the preliminary specification. Supplementary data will be published at a later date. Philips Semiconductors reserves the right to change the specification without notice, in order to improve the design and supply the best possible product.
III	Product data	Production	This data sheet contains data from the product specification. Philips Semiconductors reserves the right to make changes at any time in order to improve the design, manufacturing and supply. Relevant changes will be communicated via a Customer Product/Process Change Notification (CPCN).

[1] Please consult the most recently issued data sheet before initiating or completing a design.

[2] The product status of the device(s) described in this data sheet may have changed since this data sheet was published. The latest information is available on the Internet at URL <http://www.semiconductors.philips.com>.

[3] For data sheets describing multiple type numbers, the highest-level product status determines the data sheet status.

Definitions

Short-form specification — The data in a short-form specification is extracted from a full data sheet with the same type number and title. For detailed information see the relevant data sheet or data handbook.

Limiting values definition — Limiting values given are in accordance with the Absolute Maximum Rating System (IEC 60134). Stress above one or more of the limiting values may cause permanent damage to the device. These are stress ratings only and operation of the device at these or at any other conditions above those given in the Characteristics sections of the specification is not implied. Exposure to limiting values for extended periods may affect device reliability.

Application information — Applications that are described herein for any of these products are for illustrative purposes only. Philips Semiconductors make no representation or warranty that such applications will be suitable for the specified use without further testing or modification.

Disclaimers

Life support — These products are not designed for use in life support appliances, devices, or systems where malfunction of these products can reasonably be expected to result in personal injury. Philips Semiconductors customers using or selling these products for use in such applications do so at their own risk and agree to fully indemnify Philips Semiconductors for any damages resulting from such application.

Right to make changes — Philips Semiconductors reserves the right to make changes in the products—including circuits, standard cells, and/or software—described or contained herein in order to improve design and/or performance. When the product is in full production (status 'Production'), relevant changes will be communicated via a Customer Product/Process Change Notification (CPCN). Philips Semiconductors assumes no responsibility or liability for the use of any of these products, conveys no license or title under any patent, copyright, or mask work right to these products, and makes no representations or warranties that these products are free from patent, copyright, or mask work right infringement, unless otherwise specified.

Contact information

For additional information please visit
<http://www.semiconductors.philips.com>. Fax: +31 40 27 24825

© Koninklijke Philips Electronics N.V. 2003
 All rights reserved. Printed in U.S.A.

Date of release: 10-03

For sales offices addresses send e-mail to:
sales.addresses@www.semiconductors.philips.com

Document order number:

9397 750 12114

Let's make things better.

Philips
Semiconductors



PHILIPS