

Programmable Single-/Dual-/Triple- Tone Gong

SAE 800

Pb-free lead plating; RoHS compliant

Bipolar IC

Features

- Supply voltage range 2.8 V to 18 V
- Few external components (no electrolytic capacitor)
- 1 tone, 2 tones, 3 tones programmable
- Loudness control
- Typical standby current 1 μ A
- Constant current output stage (no oscillation)
- High-efficiency power stage
- Short-circuit protection
- Thermal shutdown

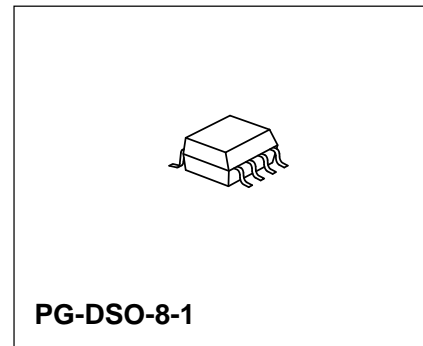
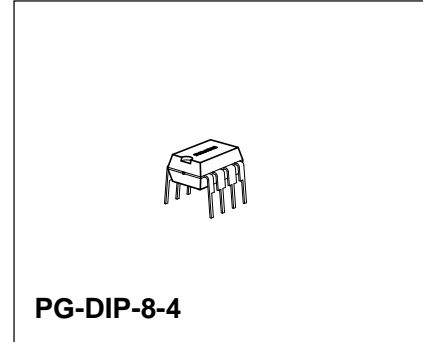
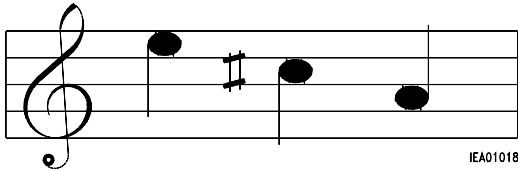

Type	Ordering Code	Package
▼ SAE 800	Q67000-A8339	PG-DIP-8-4
▼ SAE 800 G	Q67000-A8340	PG-DSO-8-1 (SMD)

▼ New type

Functional Description

The SAE 800 is a single-tone, dual-tone or triple-tone gong IC designed for a very wide supply voltage range. If the oscillator is set to $f_0 = 13.2$ kHz for example, the IC will issue in **triple-tone-mode** the minor and major third $e^2 - C$ sharp - a, corresponding to 660 Hz - 550 Hz - 440 Hz, in **dual-tone-mode** the minor third $e^2 - C$ sharp, and in **single-tone-mode** the tone e^2 (derived from the fundamental frequency f_0 ; $f_1 = f_0 / 20$, $f_2 = f_0 / 24$, $f_3 = f_0 / 30$).

When it is not triggered, the IC is in a standby state and only draws a few μ A. It comes in a compact P-DIP-8-1 or P-DSO-8-1 (SMD) package and only requires a few external components.

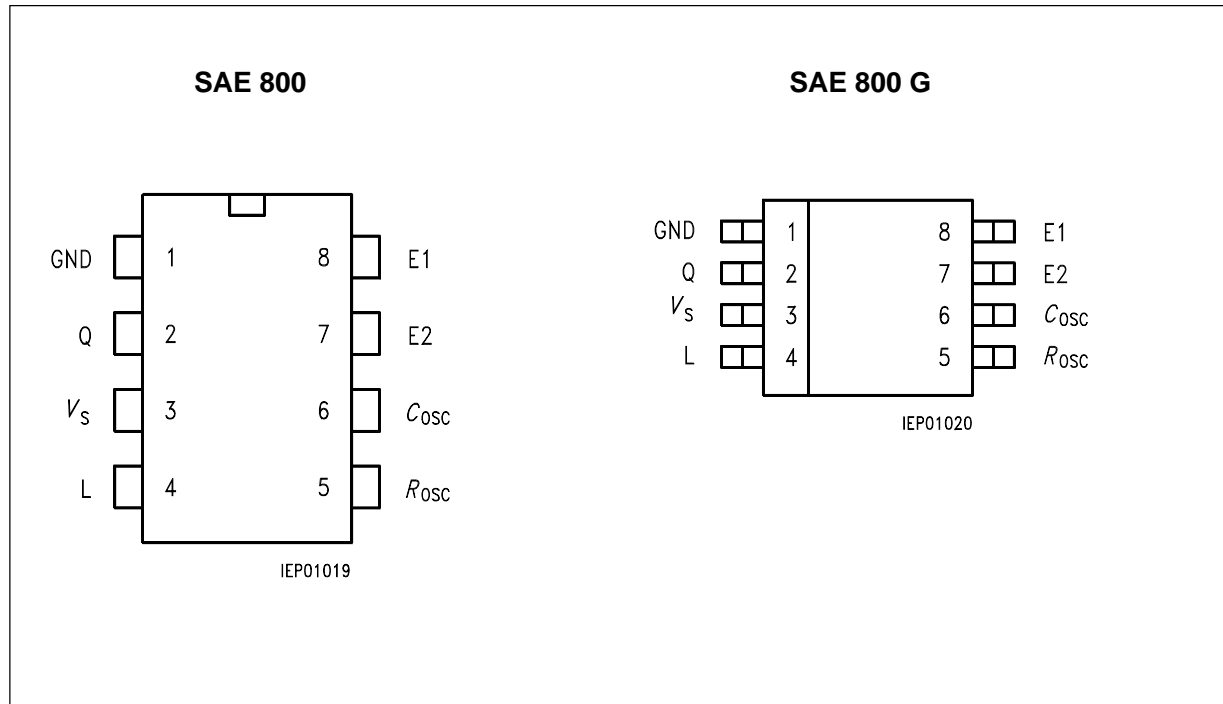

Pin Configuration (top view)

Pin Definitions and Functions

Pin	Symbol	Function
1	GND	Ground
2	Q	Output
3	V_s	Supply Voltage
4	L	Loudness Control
5	R_{osc}	Oscillator Resistor
6	C_{osc}	Oscillator Capacitor
7	E2	Trigger 2 (dual tone)
8	E1	Trigger 1 (single tone)

Functional Description (cont'd)

An RC combination is needed to generate the fundamental frequency (pin R_{osc} , C_{osc}). The volume can be adjusted with another resistor (pin L). The loudspeaker must be connected directly between the output Q and the power supply V_s . The current-sink principle combined with an integrated thermal shutdown (with hysteresis) makes the IC overload-protected and shortcircuit-protected.

There are two trigger pins (E1, E2) for setting single-tone, dual-tone or triple-tone mode.

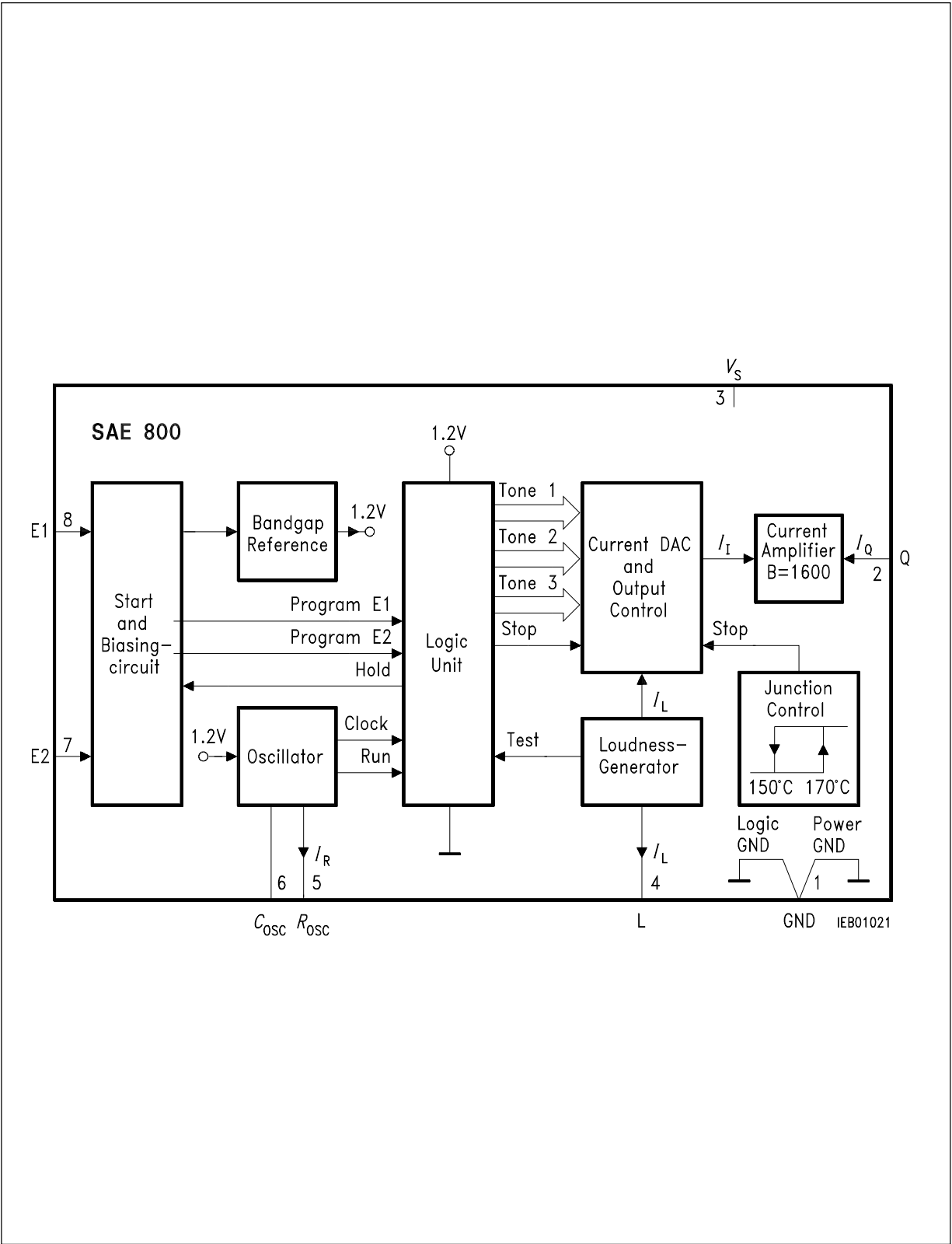

Block Diagram

Circuit Description

Trigger

Positive pulses on inputs E1 and/or E2 trigger the IC. The hold feedback in the logic has a delay of several milliseconds. After this delay has elapsed, the tone sequence is started. This prevents parasitic spikes from producing any effect on the trigger pins.

The following **table** shows the trigger options:

E1	E2	Mode	Issued Sequence
Triggered	Triggered	Triple-tone	Minor and major third
Grounded/open	Triggered	Dual-tone	Minor third
Triggered	Grounded/open	Single-tone	1st tone of minor third

Oscillator

This is a precision triangle oscillator with an external time constant ($R \times C$). Capacitor C_C on pin C_{OSC} is charged by constant current to 1 V and then discharged to 0.5 V. The constant current is obtained on pin R_{OSC} with an external resistor R_R to ground.

When the voltage on C_{OSC} is building up, the logic is reset at 350 mV. This always ensures that a complete tone sequence is issued. If the oscillator pin is short-circuited to GND during operation, the sequence is repeated.

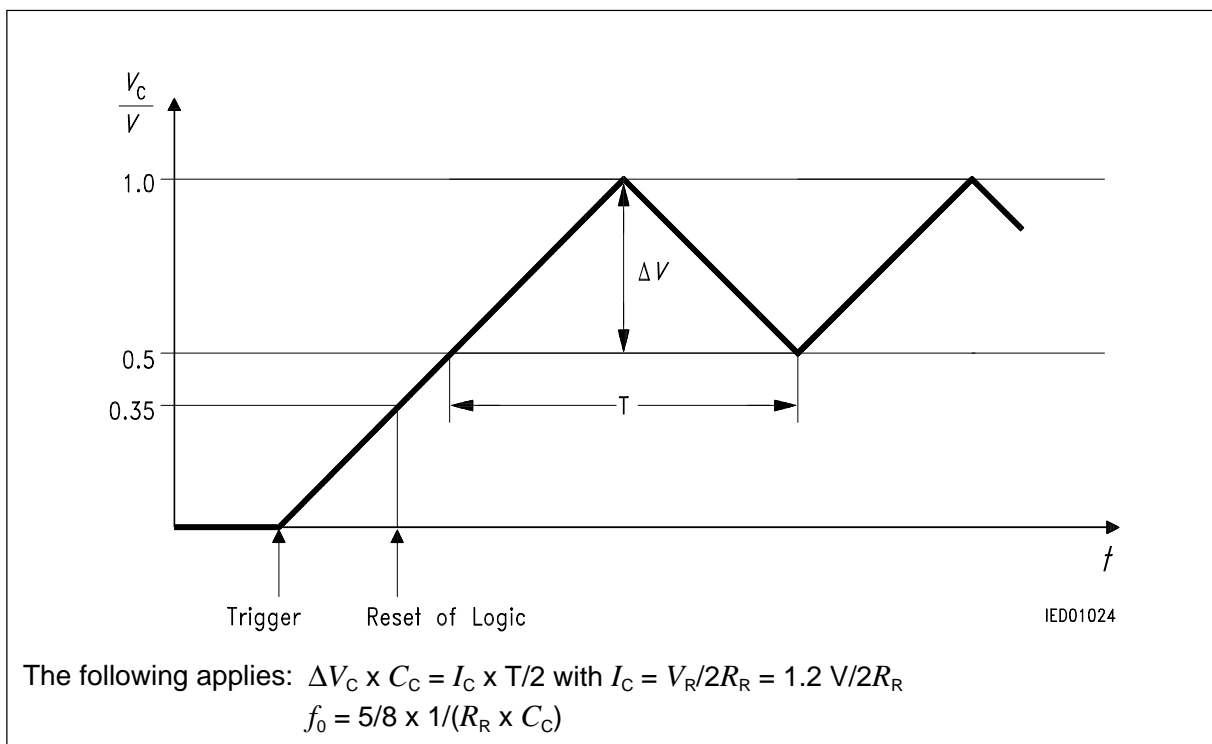

Voltages on Pin C_{OSC}

Logic

The logic unit contains the complete sequence control. The oscillator produces the power-on reset and the clock frequency. Single-tone, dual-tone or triple-tone operation is programmed on inputs E1 and E2. The 4-bit digital/analog converters are driven in parallel. In the event of oscillator disturbance, and after the sequence, the dominant stop output is set. By applying current to pin L, the sequence can be shortened by a factor of 30 for test purposes.

The following figure shows the envelope of the triple-tone sequence:

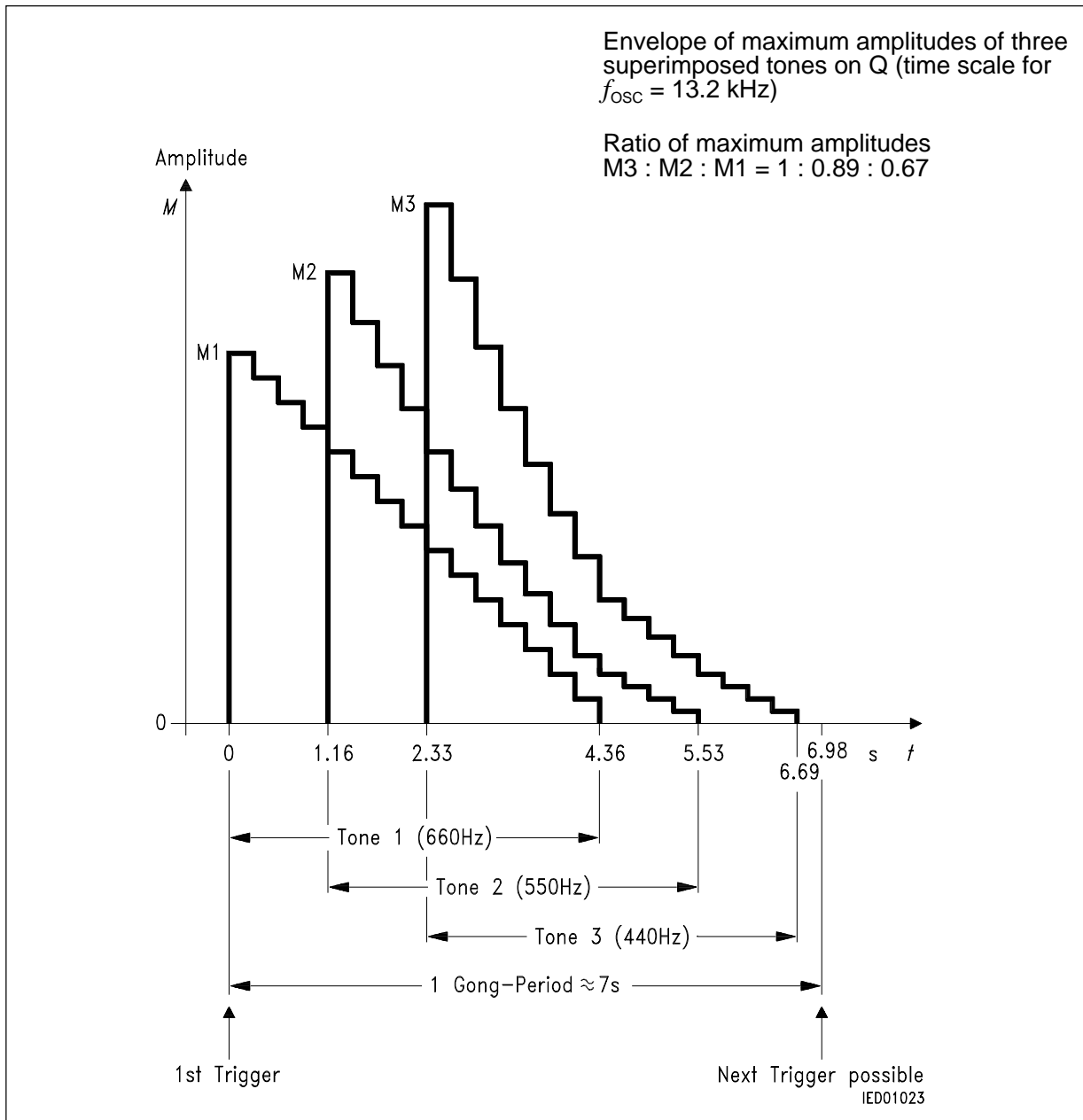

Envelope of the Triple-Tone Sequence

Digital / Analog Converter, Loudness and Junction Control

The DAC converts the 4-bit words from the logic into the appropriate staircase currents with the particular tone frequency. The sum current I_1 drives the following current amplifier. The loudness generator produces the DAC reference current I_L for all three tones. This requires connecting an external resistor to ground. The chip temperature is monitored by the junction control. At temperatures of more than approx. 170 °C the stop input will switch the output current I_1 to zero. The output current is enabled again once the chip has cooled down to approx. 150 °C.

Current Amplifier

The current amplifier with a gain of 1600 boosts the current I_1 from approx. 470 μA maximum to approx. 750 mA maximum. The output stage consists of an NPN transistor with its emitter on power GND and collector on pin Q.

The current control insures that the output stage only conducts defined currents. In conjunction with the integrated thermal shutdown, this makes the configuration shortcircuit-protected within wide limits. Because of the absence of feedback the circuit is also extremely stable and therefore uncritical in applications. Resistor R_L on pin L sets the output voltage swing. This assumes that the resistive component of the loudspeaker impedance R_Q responds similarly as the resistance R_L .

The output amplitude of the current I_1 reaches the maximum $I_{I_{max}} \cong 3 \times V_L / R_L$ at a time t of 2.33 s (only 3 tone mode), so R_L has to be scaled for this point.

The following applies:

$$I_Q = I_{I_{max}} \times B = (V_S - V_{sat}) / R_Q \approx 0.8 V_S / R_Q$$

$$3 \times B \times (V_L / R_L) \approx 0.8 V_S / R_Q$$

the result is:

$$R_L = R_Q \times 3 \times B \times (V_L / 0.8 V_S)$$

$$\text{with: } B = 1600$$

$$R_L = R_Q \times K \times (V_L / 0.8 V_S)$$

$$\text{with: } K = 4800$$

Application Hints and Application Circuit

1) Loudness Resistor (max. Load Current of 3-Tone Signal with Ensured Ratio of Amplitudes)

$$0.8 V_S / R_Q \approx (V_L / R_L) \times K$$

$$R_L = (V_L / 0.8 V_S) \times R_Q \times K; K = 4800$$

Example: $R_Q = 8 \Omega$; $V_S = 5 V$; $V_L = 1.2 V$

$$R_L = (1.2 / 4) \times 8 \Omega \times 4800 \approx 12 k\Omega$$

2) Oscillator Elements R_R , C_C

$$f = 5 / 8 \times 1 / (R_R \times C_C)$$

Example: $f = 13.2 kHz$; $C_C = 4.7 nF$

$$R_R = 5 / (8 \times 13.2 \times 4.7) \times 10^6 \Omega \approx 10 k\Omega$$

The following is a typical application circuit

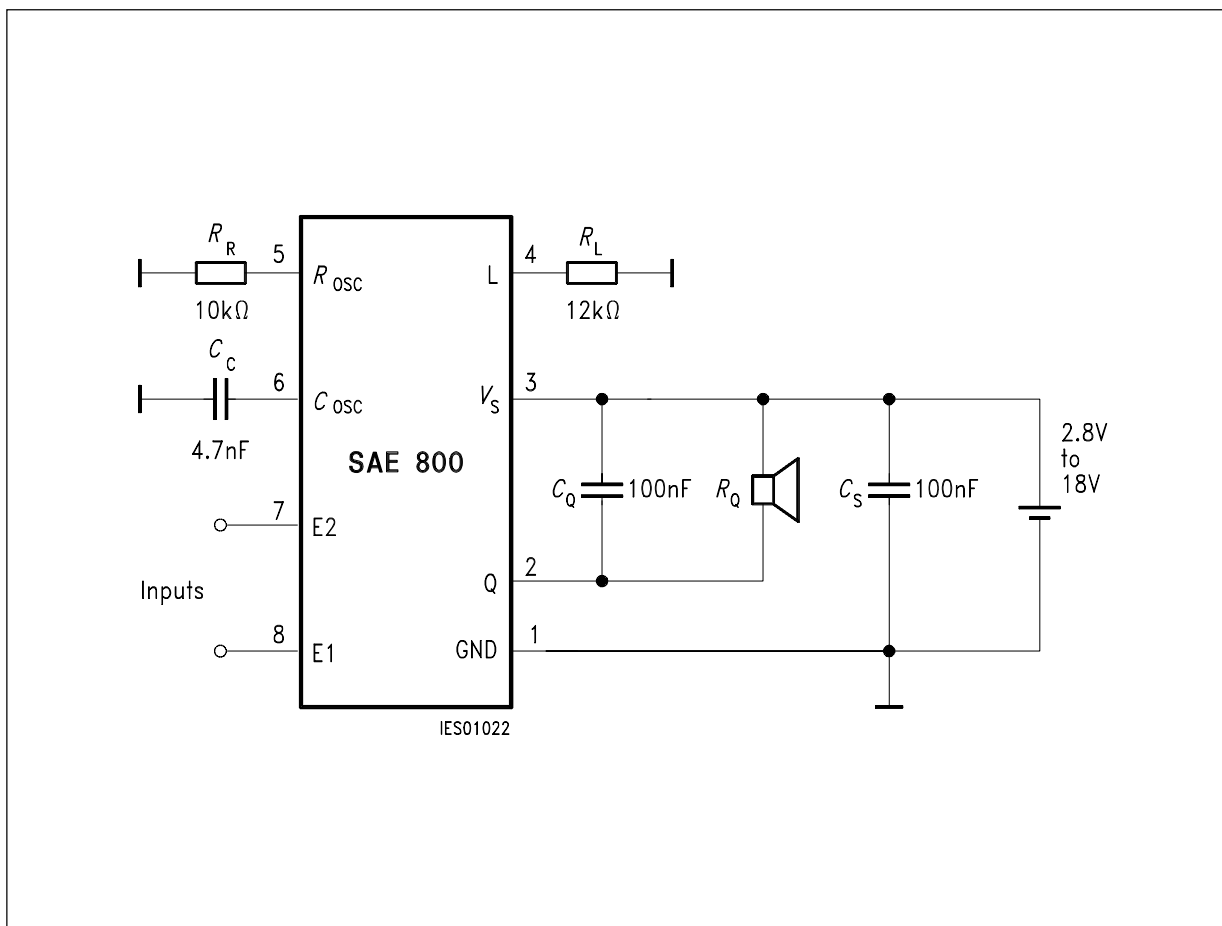

Application Circuit

Absolute Maximum Ratings

Parameter	Symbol	Limit Values		Unit
		min.	max.	
Supply voltage	V_S	- 0.3	24	V
Input voltage at E1, E2	$V_{E1, E2}$	- 5	24	V
Current at output Q	I_Q	- 50	750	mA
Current at input pins E1, E2	$I_{E1, E2}$	- 2	3	mA
Current at pin R_{OSC}	I_R	- 300	200	μA
Current at pin L	I_L	- 300	200	μA
Current at pin C_{OSC}	I_C	- 200	200	μA
Junction temperature	T_j	- 50	150	$^{\circ}C$
Storage temperature	T_{stg}	- 50	150	$^{\circ}C$

Operating Range

Supply voltage	V_S	2.8	18	V
Junction temperature	T_j	- 25	125	$^{\circ}C$
Oscillator frequency at C_{OSC}	f_C		100	kHz
Current at pin R_{OSC}	I_R	- 200	- 10	μA
Current for test mode at pin L	I_R	90	110	μA
Current at pin L	I_L	- 200	- 10	μA
Input voltage at E1, E2	$V_{E1, E2}$	- 4	18	V
Thermal resistance junction-air (PG-DIP-8-4)	$R_{th JA}$		100	K/W
junction-air (PG-DSO-8-1)	$R_{th JA}$		180	K/W

Characteristics

$T_j = -25$ to 125°C ; $V_S = 2.8$ to 18 V

Parameter	Symbol	Limit Values			Unit	Test Condition
		min.	typ.	max.		

Supply Section

Standby current	I_{St}		1	10	μA	
Quiescent current; pin L open	I_{Qu}		5	10	mA	

Output Section

Peak output power (tone 3)						
$V_S = 2.8$ V; $R_Q = 4$ Ω ; $R_L = 8.2$ k Ω	P_Q	250	330		mW	A
$V_S = 2.8$ V; $R_Q = 8$ Ω ; $R_L = 18$ k Ω	P_Q	125	165		mW	
$V_S = 5.0$ V; $R_Q = 8$ Ω ; $R_L = 10$ k Ω	P_Q	450	600		mW	
$V_S = 5.0$ V; $R_Q = 16$ Ω ; $R_L = 18$ k Ω	P_Q	225	300		mW	
$V_S = 12$ V; $R_Q = 50$ Ω ; $R_L = 33$ k Ω	P_Q	450	600		mW	
Output level differences:						
tone 1 to 3	a_{13}	-1		1	dB	A ¹⁾
tone 2 to 3	a_{23}	-1		1	dB	A ²⁾

Biasing Section

Voltage at pin R_{OSC} ; $R_R = 10$ k Ω	V_R		1.2		V	
Voltage at pin L; $R_L = 10$ k Ω	V_L		1.2		V	

Oscillator Section

Amplitude	ΔV_C		0.5		V	
Frequency $R_R = 10$ k Ω ; $C_C = 4.7$ nF	f_0		13.2		kHz	
Oscill. drift vs. temperature	D_T	-3		+3	$10^{-4}/\text{K}$	
Oscill. drift vs. supply voltage	D_V		1		$10^{-3}/\text{K}$	

Input Section

Triggering voltage at E1, E2	$V_{E1, E2}$	1.6			V	
Triggering current at E1, E2	$I_{E1, E2}$	100			μA	
Noise voltage immunity at E1, E2	$V_{E1, E2}$			0.3	V	
Triggering delay at $f_0 = 13.2$ kHz	t_{dT}	2		10	ms	

1) $a_{13} = 20 \times \log (M1 / (0.67 \times M3))$

2) $a_{23} = 20 \times \log (M2 / (0.89 \times M3))$

Output Peak Voltage V_Q versus Loudness-Current I_L

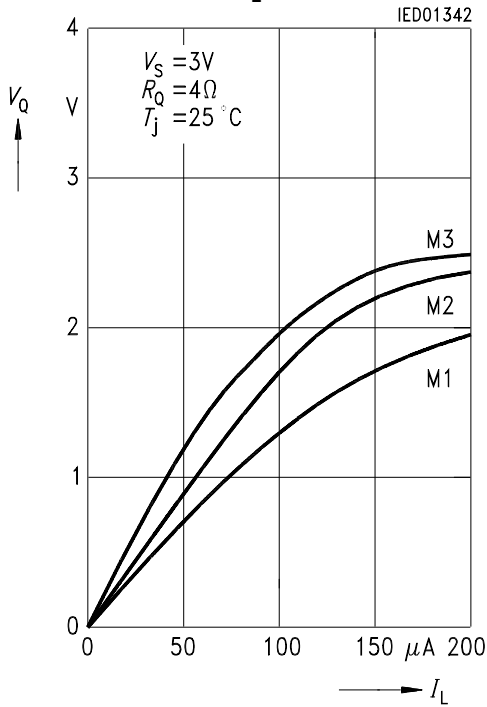

Max. Output Power P_Q versus Loudness-Current I_L

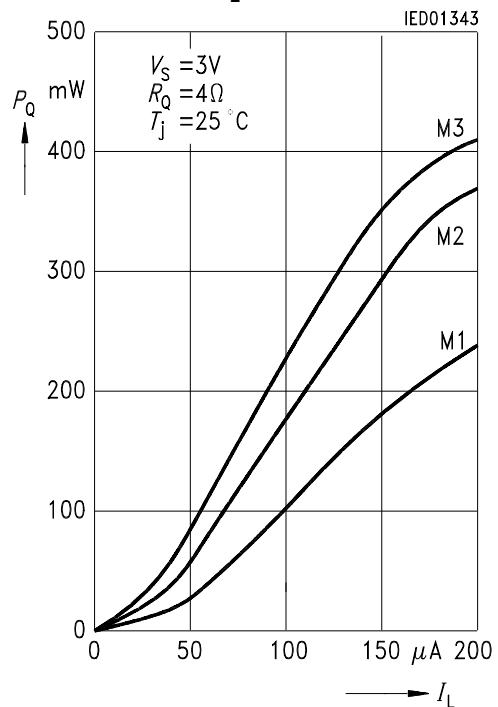

Power Dissipation P_V of Output Stage versus Loudness-Current I_L

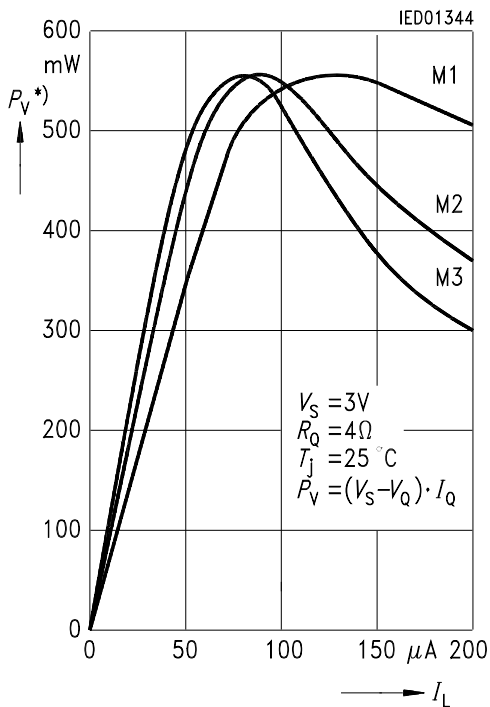

Peak Current I_Q versus Loudness-Current I_L

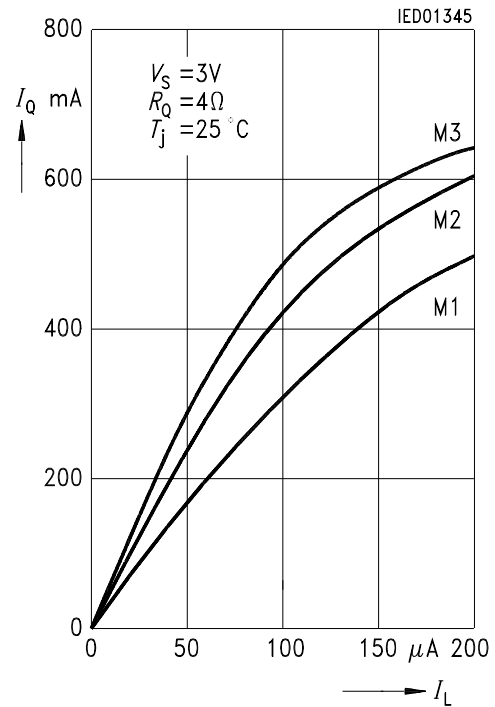

*) Note that $I_Q = f(I_L)$ varies between 0 and $K \cdot I_L$ during tone sequence. Thereby the maximum of the power dissipation during the tone sequence is the maximum of P_V (in diagram) between $I_L = 0$ and chosen $I_L = V_L/R_L$.

Output Peak Voltage V_Q versus Loudness-Current I_L

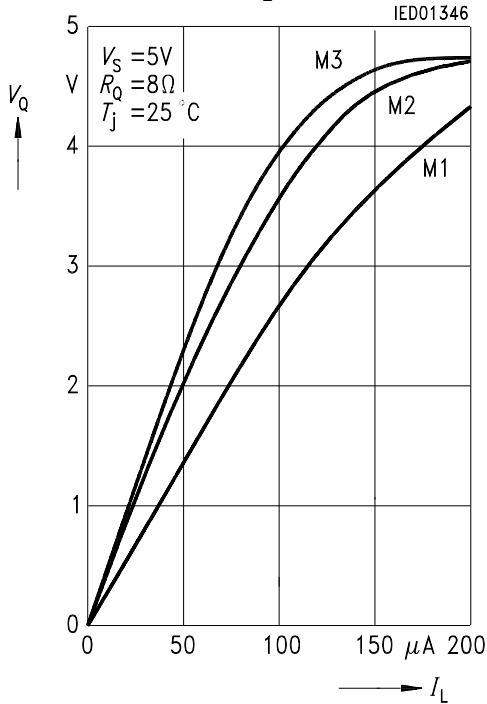

Max. Output Power P_Q versus Loudness-Current I_L

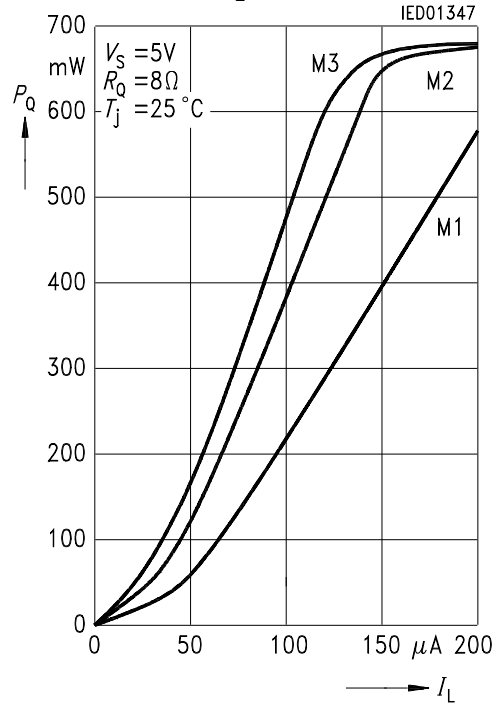

Power Dissipation P_V of Output Stage versus Loudness-Current I_L

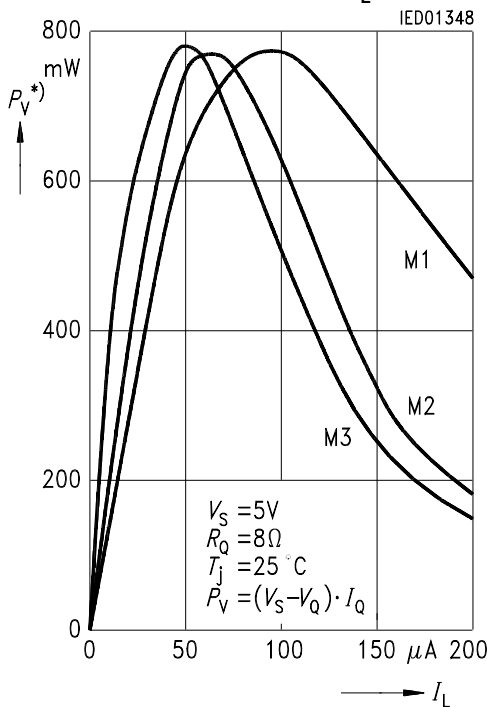

Peak Current I_Q versus Loudness-Current I_L

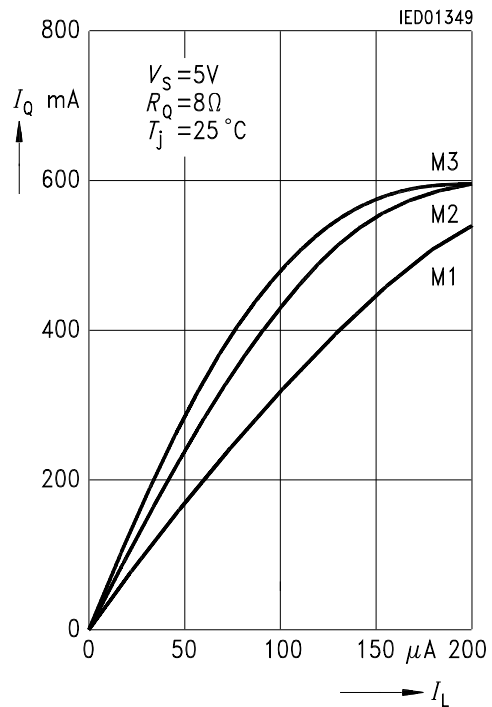

*) Note that $I_Q = f(I_L)$ varies between 0 and $K \cdot I_L$ during tone sequence. Thereby the maximum of the power dissipation during the tone sequence is the maximum of P_V (in diagram) between $I_L = 0$ and chosen $I_L = V_Q/R_L$.

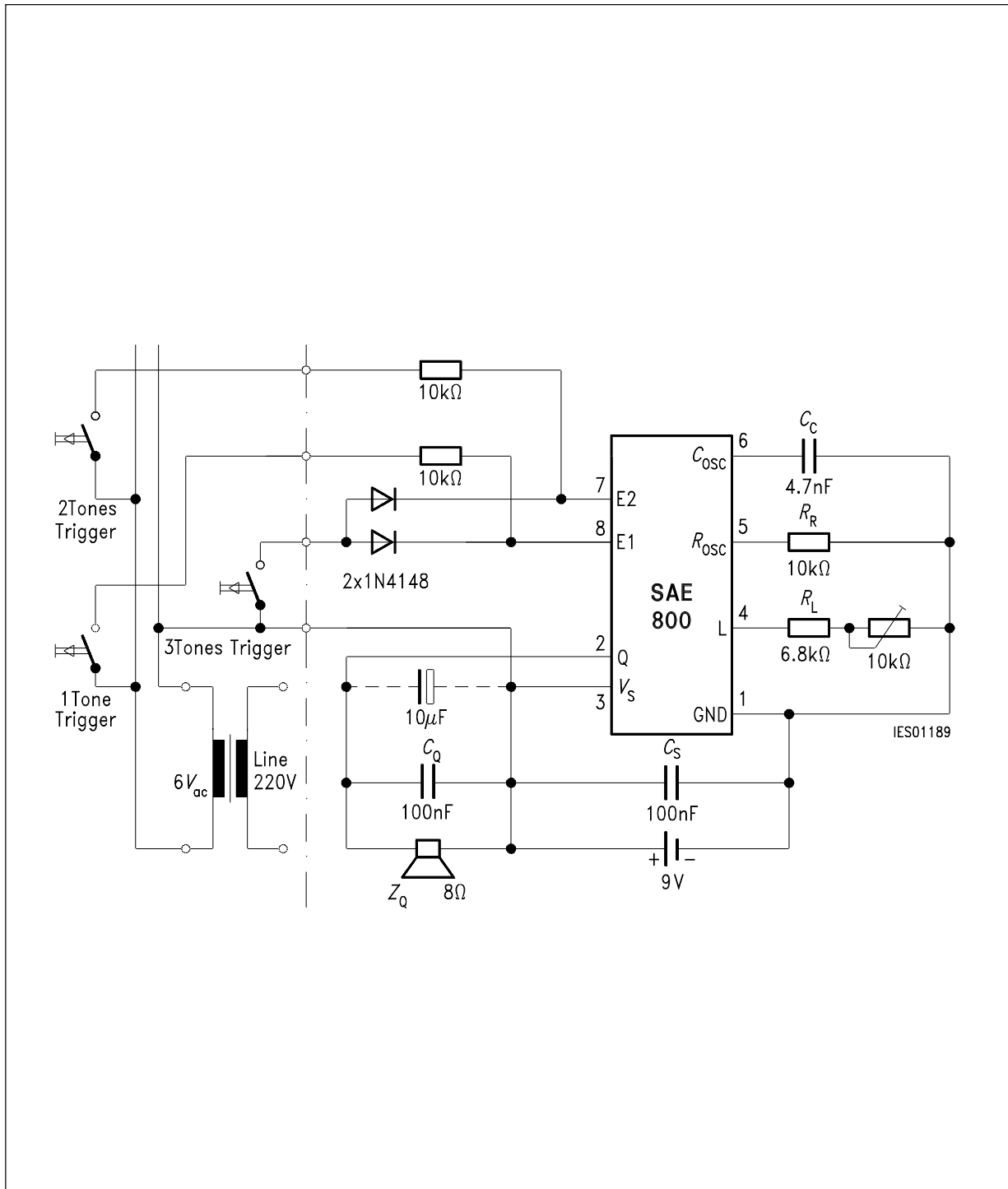

Circuit for SAE 800 Application in Home Chime Installation Utilizing AC and DC Triggering for 1, 2 or 3 Tone Chime; Adjustable Volume

PCB layout information: Because of the peak currents at V_s, Q and GND the lines should be designed in a flatspread way or as star pattern.

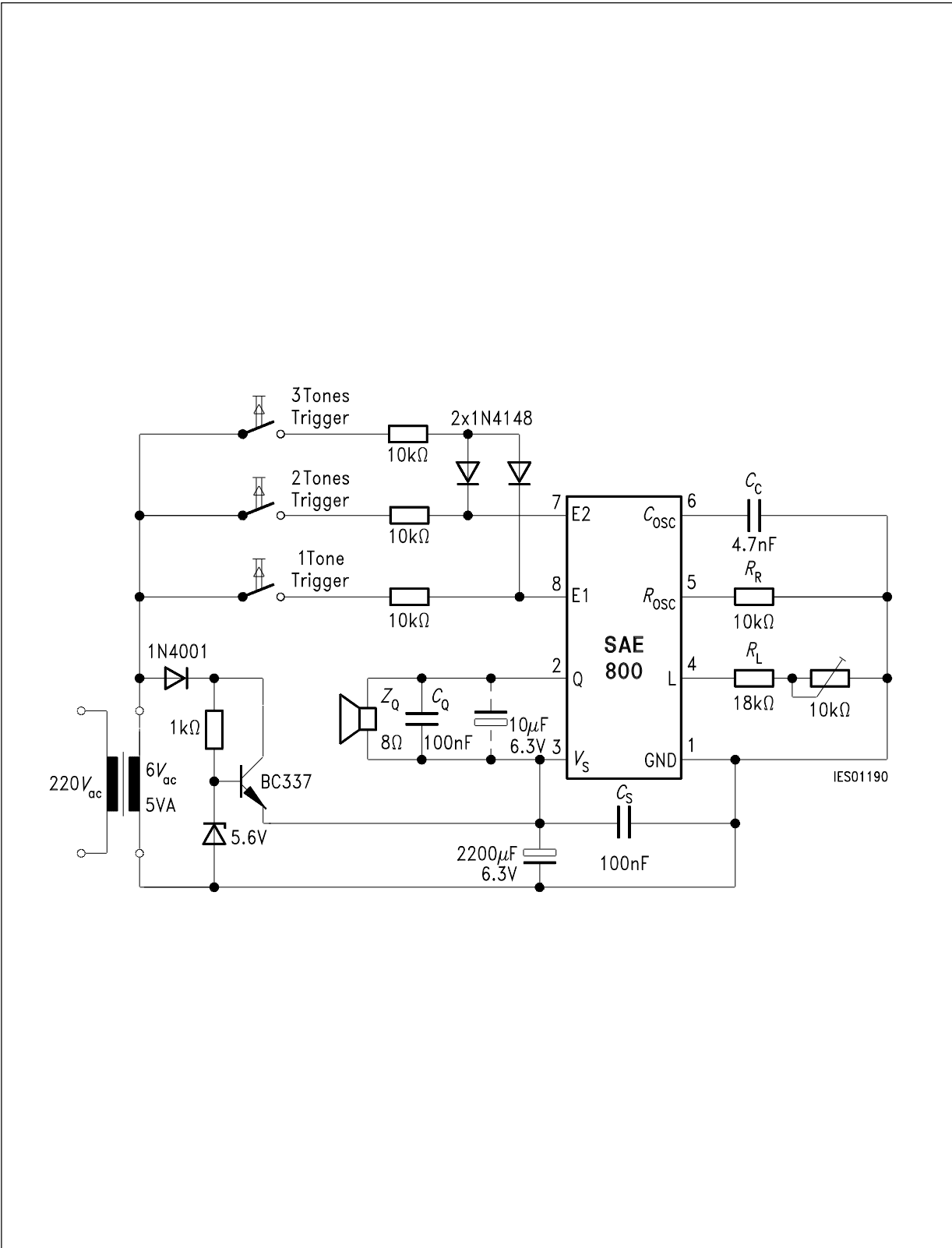

Circuit for SAE 800 Application in Home Chime Installation for Operation without Battery

Downloaded from Elcodis.com electronic components distributor

Package Outlines

Plastic-Package, PG-DIP-8-4 (Plastic Dual In-Line Package)

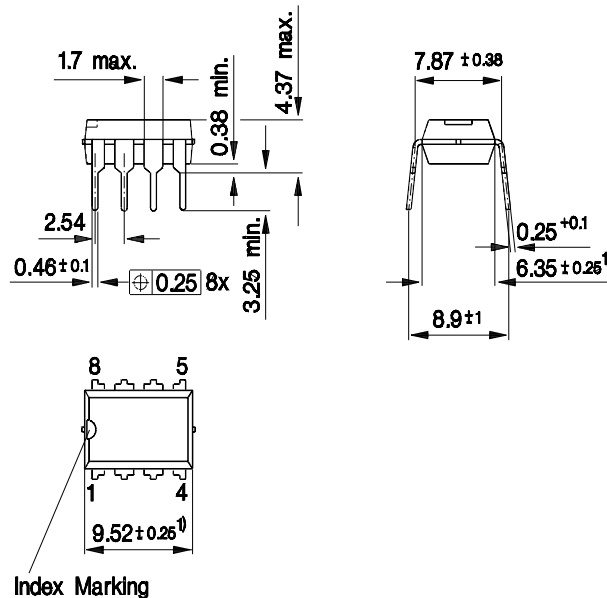

1) Does not include plastic or metal protrusion of 0.25 max. per side

GPD05583

Plastic-Package, PG-DSO-8-1 (SMD) (Plastic Dual Small Outline)

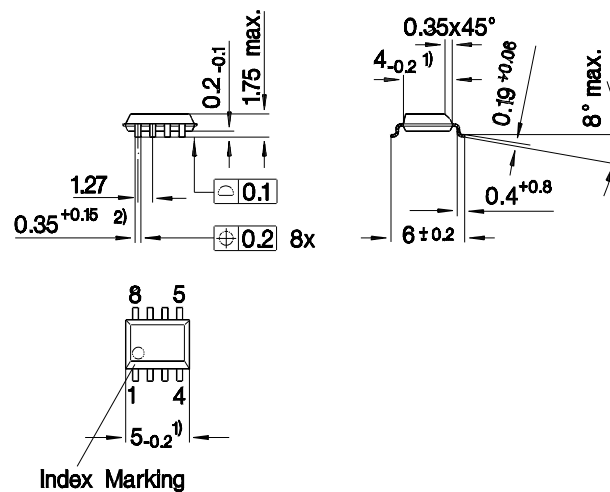

1) Does not include plastic or metal protrusion of 0.15 max. per side
2) Does not include dambar protrusion

GPS05121

SMD = Surface Mounted Device

Dimensions in mm