



**INA104**

## Very-High Accuracy INSTRUMENTATION AMPLIFIER

### FEATURES

- VERSATILE FOUR OP AMP DESIGN
- ULTRA-LOW VOLTAGE DRIFT: 0.25 $\mu$ V/ $^{\circ}$ C, max
- LOW OFFSET VOLTAGE: 25 $\mu$ V, max
- LOW NONLINEARITY: 0.002%, max
- LOW NOISE: 13nV/ $\sqrt{\text{Hz}}$  at  $f_0 = 1\text{kHz}$
- HIGH CMR: 106dB at 60Hz, min
- HIGH INPUT IMPEDANCE:  $10^{10}\Omega$
- LOW COST

### APPLICATIONS

- AMPLIFICATION OF SIGNALS FROM SOURCES SUCH AS:  
Strain Gages  
Thermocouples  
RTDs
- REMOTE TRANSDUCER AMPLIFIER
- LOW LEVEL SIGNAL CONDITIONER
- MEDICAL INSTRUMENTATION

### DESCRIPTION

The INA104 is a high accuracy, multistage, integrated-circuit instrumentation amplifier designed for signal conditioning requirements where very high performance is desired.

A multi-amplifier, monolithic design, which uses Burr-Brown's ultra-low drift, low-noise technology, provides the highest performance with maximum versatility at the lowest cost and makes the INA104 ideal for even high volume applications.

Burr-Brown's compatible thin-film resistors and laser-trimming techniques are used for minimizing offset voltage and temperature drift. This advanced technique also maximizes common-mode rejection and gain accuracy.

The INA104 also contains a fourth operational amplifier, specified separately, which can conveniently be used for some important applications such as single capacitor active low-pass filtering, easy output level shifting, common-mode voltage active guard drive, and increased gain ( $\times 10,000$  and greater).

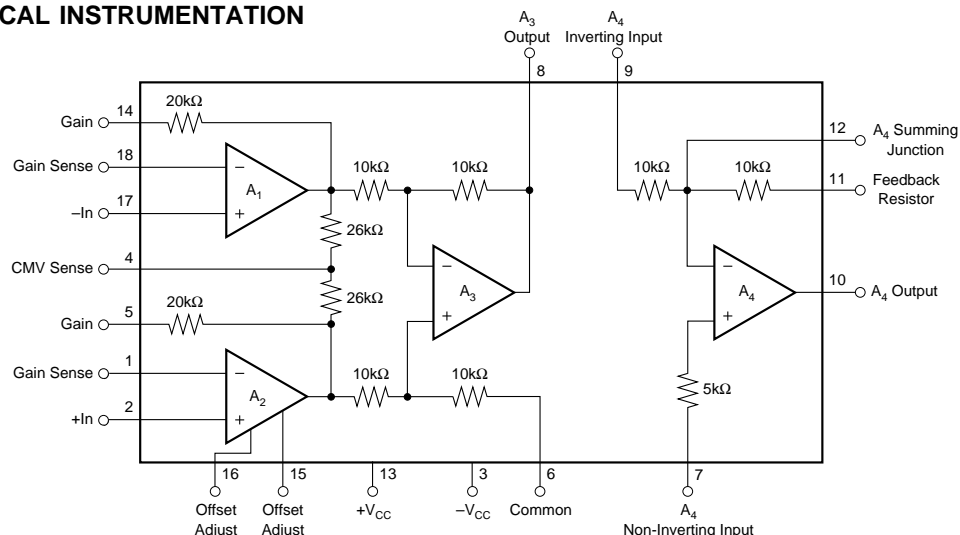

International Airport Industrial Park • Mailing Address: PO Box 11400 • Tucson, AZ 85734 • Street Address: 6730 S. Tucson Blvd. • Tucson, AZ 85706  
Tel: (520) 746-1111 • Twx: 910-952-1111 • Cable: BBRCORP • Telex: 066-6491 • FAX: (520) 889-1510 • Immediate Product Info: (800) 548-6132

# SPECIFICATIONS—INSTRUMENTATION AMPLIFIER

At  $T_A = +25^\circ\text{C}$ ,  $V_S = \pm 15\text{V}$  power supply and in circuit of Figure 1 unless otherwise noted.

PARAMETER	INA104AM			INA104BM, SM			INA104CM			UNITS
	MIN	TYP	MAX	MIN	TYP	MAX	MIN	TYP	MAX	
<b>GAIN</b>										
Range of Gain	1		1000	*	*	*	*	*	*	V/V
Gain Equation		$G = 1 + (40k/R_G)$			*	*		*	*	V/V
Error From Equation, DC <sup>(1)</sup>		$\pm(0.08 - 0.05/G)$	$\pm(0.15 - 0.1/G)$		*	*		*	*	% of FS
Gain Temp. Coefficient <sup>(2)</sup>					*	*		*	*	ppm/°C
G = 1		2	5		*	*		*	*	ppm/°C
G = 10		20	100		*	*		-10	-50	ppm/°C
G = 100		22	110		*	*		-11	-55	ppm/°C
G = 1000		22	110		*	*		-11	-55	ppm/°C
Nonlinearity, DC		$\pm(0.002 + 10^{-5}G)$	$\pm(0.005 + 2 \times 10^{-5}G)$		$\pm(0.001 + 10^{-5}G)$	$\pm(0.002 + 10^{-5}G)$		$\pm(0.001 + 10^{-5}G)$	$\pm(0.002 + 10^{-5}G)$	% of FS, p-p
<b>RATED OUTPUT</b>										
Voltage	$\pm 10$	+11.5, -12.5		*	*		*	*		V
Current	$\pm 5$	+11.5, -12.5		*	*		*	*		mA
Output Impedance		0.2			*			*		$\Omega$
<b>INPUT OFFSET VOLTAGE</b>										
Initial Offset at +25°C <sup>(3)</sup>		$\pm 25 \pm 200/G$	$\pm 50 \pm 400/G$		$\pm 10 \pm 100/G$	$\pm 25 \pm 200/G$		$\pm 10 \pm 100/G$	$\pm 25 \pm 200/G$	$\mu\text{V}$
vs Temperature			$\pm 2 \pm 20/G$			$\pm 0.75 \pm 10/G$			$\pm 0.25 \pm 10/G$	$\mu\text{V}/^\circ\text{C}$
vs Supply		$\pm(1 + 50/G)$			*			*		$\mu\text{V}/\text{V}$
vs Time		$\pm(1 + 20/G)$			*			*		$\mu\text{V}/\text{mo}$
<b>INPUT BIAS CURRENT</b>										
Initial Bias Current (each input)		$\pm 15$	$\pm 30$		$\pm 10$	*		$\pm 5$	$\pm 20$	nA
vs Temperature		$\pm 0.2$			*			*		nA/°C
vs Supply		$\pm 0.1$			*			*		nA/V
Initial Offset Current		$\pm 5$	$\pm 30$		$\pm 2$	*		$\pm 2$	$\pm 20$	nA
vs Temperature		$\pm 0.5$			*			*		nA/°C
<b>INPUT IMPEDANCE</b>										
Differential		$10^{10} \parallel 3$			*			*		$\Omega \parallel \text{pF}$
Common-Mode		$10^{10} \parallel 3$			*			*		$\Omega \parallel \text{pF}$
<b>INPUT VOLTAGE RANGE</b>										
Range, Linear Response	$\pm 10$			*			*			V
CMR with 1k $\Omega$ Source Imbalance										
DC to 60Hz, G = 1	80	90		*	*		*	*		dB
DC to 60Hz, G = 10	96	106		*	*		*	*		dB
DC to 60Hz, G = 100 to 1000	106	110		*	*		*	*		dB
<b>INPUT NOISE</b>										
Input Voltage Noise										
$f_B = 0.1\text{Hz}$ to 10Hz		0.8			*			*		$\mu\text{V}$ , p-p
Density, G = 1000					*			*		$\text{nV}/\sqrt{\text{Hz}}$
$f_O = 10\text{Hz}$		18			*			*		$\text{nV}/\sqrt{\text{Hz}}$
$f_O = 100\text{Hz}$		15			*			*		$\text{nV}/\sqrt{\text{Hz}}$
$f_O = 1\text{kHz}$		13			*			*		$\text{nV}/\sqrt{\text{Hz}}$
Input Current Noise										
$f_B = 0.01\text{Hz}$ to 10Hz		50			*			*		pA, p-p
Density					*			*		$\text{pA}/\sqrt{\text{Hz}}$
$f_O = 10\text{Hz}$		0.8			*			*		$\text{pA}/\sqrt{\text{Hz}}$
$f_O = 100\text{Hz}$		0.46			*			*		$\text{pA}/\sqrt{\text{Hz}}$
$f_O = 1\text{kHz}$		0.35			*			*		$\text{pA}/\sqrt{\text{Hz}}$
<b>DYNAMIC RESPONSE</b>										
Small Signal, $\pm 3\text{dB}$ Flatness										
G = 1		300			*			*		kHz
G = 10		140			*			*		kHz
G = 100		25			*			*		kHz
G = 1000		2.5			*			*		kHz
Small Signal, $\pm 1\%$ Flatness										
G = 1		20			*			*		kHz
G = 10		10			*			*		kHz
G = 100		1			*			*		kHz
G = 1000		200			*			*		Hz
Full Power, G = 1 - 100		6.4			*			*		kHz
Slew Rate, G = 1 - 100	0.2	0.4		*	*		*	*		V/ $\mu\text{s}$
Settling Time (0.1%)										
G = 1		30	40		*	*		*	*	$\mu\text{s}$
G = 100		40	55		*	*		*	*	$\mu\text{s}$
G = 1000		350	470		*	*		*	*	$\mu\text{s}$
Settling Time (0.01%)										
G = 1		30	45		*	*		*	*	$\mu\text{s}$
G = 100		50	70		*	*		*	*	$\mu\text{s}$
G = 1000		500	650		*	*		*	*	$\mu\text{s}$



INA104

# SPECIFICATIONS—OUTPUT AMPLIFIER, A<sub>4</sub>

At T<sub>A</sub> = +25°C, V<sub>S</sub> = ±15V power supply and in circuit of Figure 1 unless otherwise noted.

PARAMETER	INA104AM			INA104BM, SM			INA104CM			UNITS
	MIN	TYP	MAX	MIN	TYP	MAX	MIN	TYP	MAX	
<b>OPEN-LOOP GAIN</b> , V <sub>o</sub> = ±100 Rated Load R <sub>L</sub> ≥ 2kΩ R <sub>L</sub> ≥ 10kΩ	100	115		*	*		*	*		dB
	110	125		*	*		*	*		dB
<b>RATED OUTPUT</b> Voltage at R <sub>L</sub> = 2kΩ R <sub>L</sub> = 10kΩ Current Output Impedance Load Capacitance (Unity-Gain Inverting) Short Circuit Current	10	+13, -14.5		*	*		*	*		V
		+13, -14.5		*	*		*	*		V
	5	7.5		*	*		*	*		mA
		2			*			*		kΩ
		2000			*			*		pF
		10			*			*		mA
<b>FREQUENCY RESPONSE</b> Unity Gain, Small Signal Full Power Slew Rate Settling Time (Unity-Gain) 0.1% 0.01%		1			*			*		MHz
		9			*			*		kHz
	0.35	0.55		*	*		*	*		V/μs
		37			*			*		μs
		40			*			*		μs
<b>INPUT OFFSET VOLTAGE</b> Initial, T <sub>A</sub> = +25°C vs Temperature		±1	±2		*	*		*	*	mV
		±5			*			*		μV/°C
<b>INPUT BIAS CURRENT</b>		+55	+150		*	*		*	*	nA
<b>INPUT IMPEDANCE</b> Differential Common-Mode		500			*			*		kΩ
		100			*			*		MΩ
<b>RESISTORS, 10kΩ</b> Accuracy Drift Ratio Match Drift		0.5	5		*	*		*	*	%
		30	50		*	*		*	*	ppm/°C
		0.06	0.12		*	*		*	*	%
		5			*			*		ppm/°C
<b>INPUT VOLTAGE NOISE</b> f <sub>B</sub> = 0.1Hz to 10Hz Density f <sub>o</sub> = 10Hz f <sub>o</sub> = 100Hz f <sub>o</sub> = 1kHz		1.5			*			*		μV, p-p
		35			*			*		nV√Hz
		33			*			*		nV√Hz
		32			*			*		nV√Hz
						*			*	
<b>POWER SUPPLY</b> Rated Voltage Voltage Range Quiescent Current		±15			*			*	*	V
	±5		±20	*		*	*	*	*	V
		±8.1	±9.6		*	*		*	*	mA
<b>TEMPERATURE RANGE</b> Specification: AM, BM, CM SM Operation: AM, BM, CM, SM Storage: AM, BM, CM, SM θ <sub>JC</sub> θ <sub>JA</sub>	-25		+85	*		*	*	*	*	°C
	-55		+125	*		*	*	*	*	°C
			+125	*		*	*	*	*	°C
	-55		+125	*		*	*	*	*	°C
			+150	*		*	*	*	*	°C
		115			*	*		*	*	°C/W
		130			*	*		*	*	°C/W

\* Specifications same as for INA104AM.

NOTES: (1) Typically the tolerance of R<sub>G</sub> will be the major source of gain error. (2) Not including the TCR of R<sub>G</sub>. (3) Adjustable to zero at any one gain.

The information provided herein is believed to be reliable; however, BURR-BROWN assumes no responsibility for inaccuracies or omissions. BURR-BROWN assumes no responsibility for the use of this information, and all use of such information shall be entirely at the user's own risk. Prices and specifications are subject to change without notice. No patent rights or licenses to any of the circuits described herein are implied or granted to any third party. BURR-BROWN does not authorize or warrant any BURR-BROWN product for use in life support devices and/or systems.

## PIN CONFIGURATION

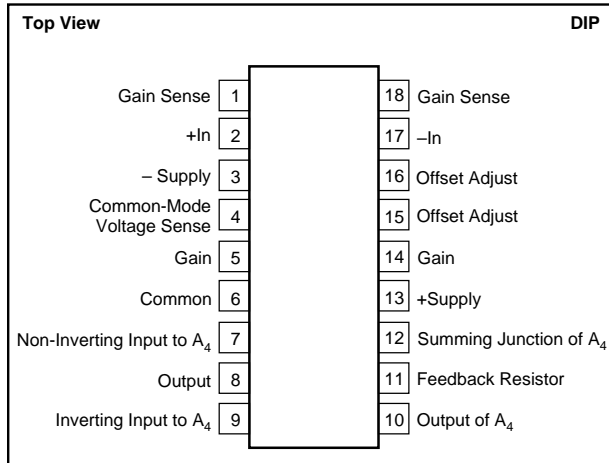

## ABSOLUTE MAXIMUM RATINGS

Supply .....	±20V
Internal Power Dissipation .....	980mW
Input Voltage Range .....	±V <sub>CC</sub>
Output Short-Circuit (to ground) .....	Continuous
Operating Temperature .....	-40°C to +125°C
Storage Temperature .....	-40°C to +125°C
Lead Temperature (soldering, 10s) .....	+300°C

## ORDERING INFORMATION

MODEL	PACKAGE	TEMPERATURE RANGE
INA104AM	18-Pin Hermetic DIP	-25°C to +85°C
INA104BM	18-Pin Hermetic DIP	-25°C to +85°C
INA104CM	18-Pin Hermetic DIP	-25°C to +85°C
INA104SM	18-Pin Hermetic DIP	-55°C to +125°C

## PACKAGE INFORMATION<sup>(1)</sup>

MODEL	PACKAGE	PACKAGE DRAWING NUMBER
INA104AM	18-Pin Hermetic DIP	108
INA104BM	18-Pin Hermetic DIP	108
INA104CM	18-Pin Hermetic DIP	108
INA104SM	18-Pin Hermetic DIP	108

NOTE: (1) For detailed drawing and dimension table, please see end of data sheet, or Appendix D of Burr-Brown IC Data Book.



## ELECTROSTATIC DISCHARGE SENSITIVITY

This integrated circuit can be damaged by ESD. Burr-Brown recommends that all integrated circuits be handled with appropriate precautions. Failure to observe proper handling and installation procedures can cause damage.

ESD damage can range from subtle performance degradation to complete device failure. Precision integrated circuits may be more susceptible to damage because very small parametric changes could cause the device not to meet its published specifications.

# TYPICAL PERFORMANCE CURVES

At  $T_A = +25^\circ\text{C}$ ,  $V_{CC} = 15\text{V}$ , and in circuit of Figure 1, unless otherwise specified.

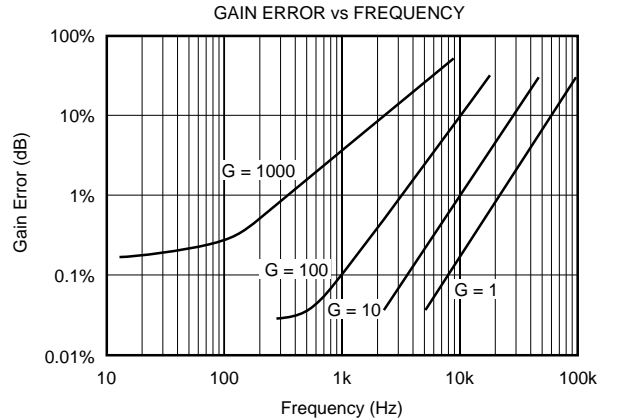
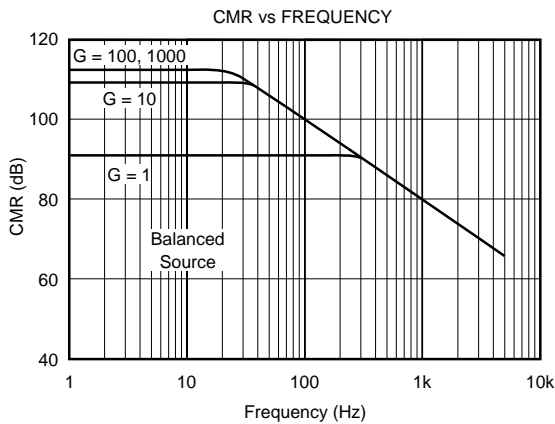
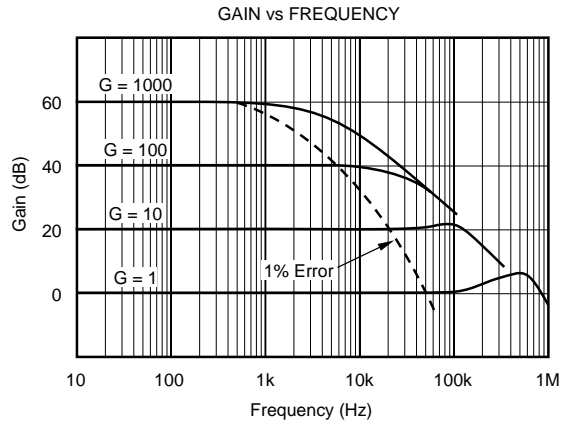
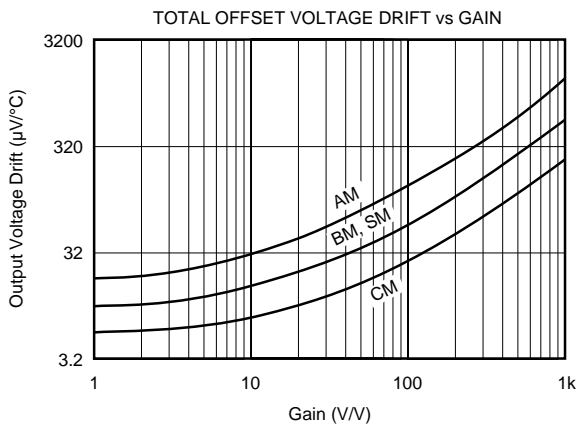
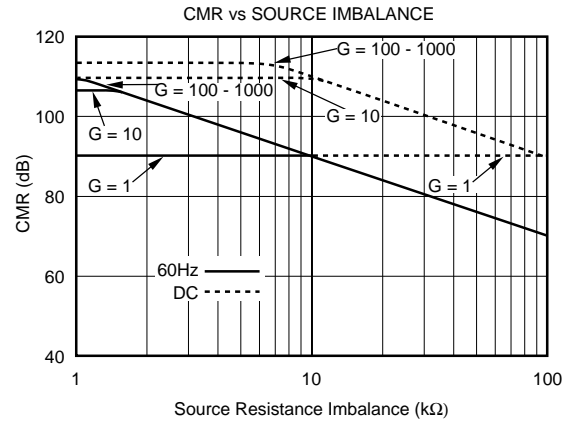
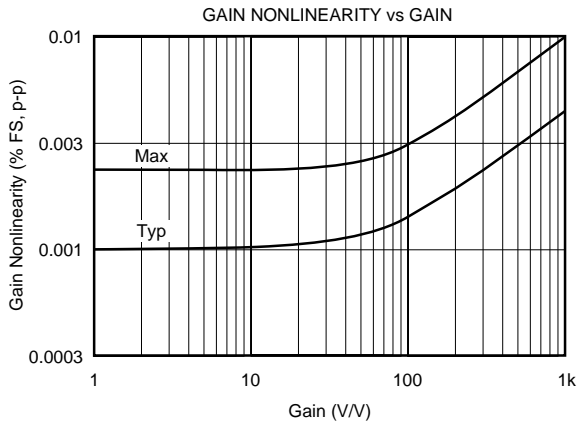

# TYPICAL PERFORMANCE CURVES (CONT)

At  $T_A = +25^\circ\text{C}$ ,  $V_{CC} = 15\text{V}$ , and in circuit of Figure 1, unless otherwise specified.

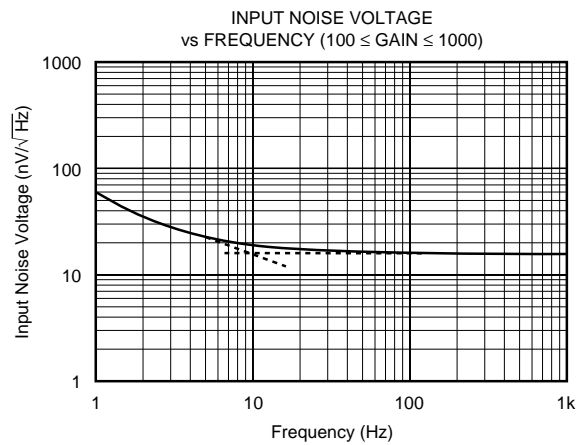
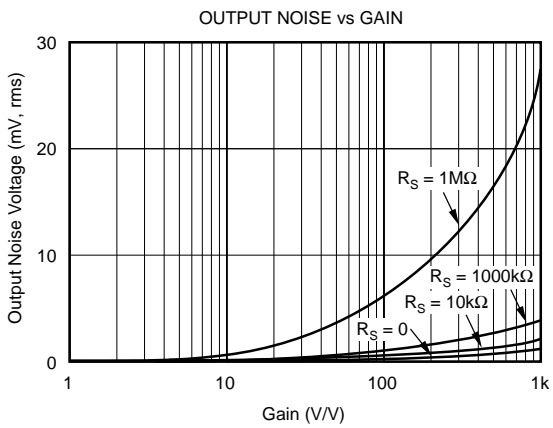
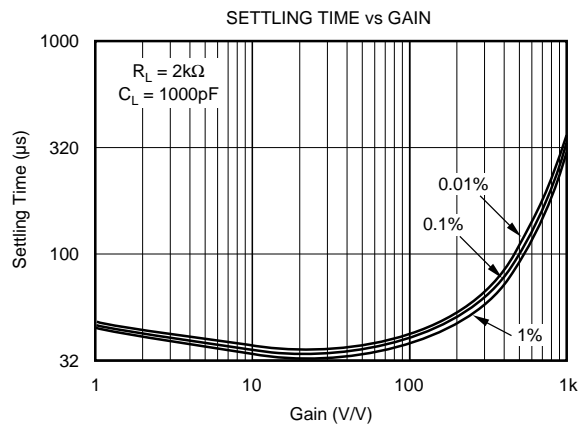
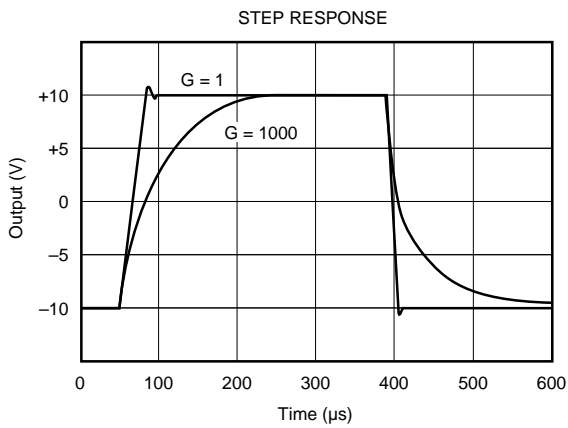
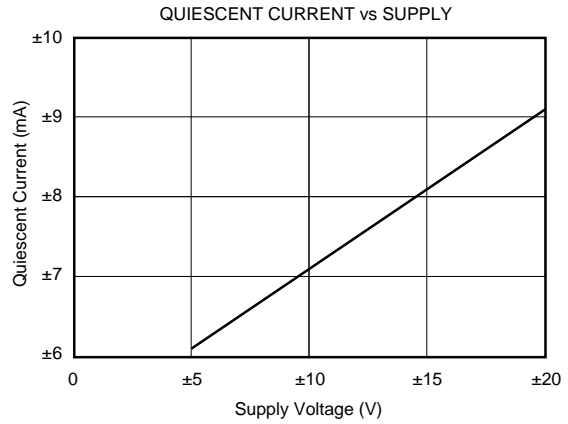
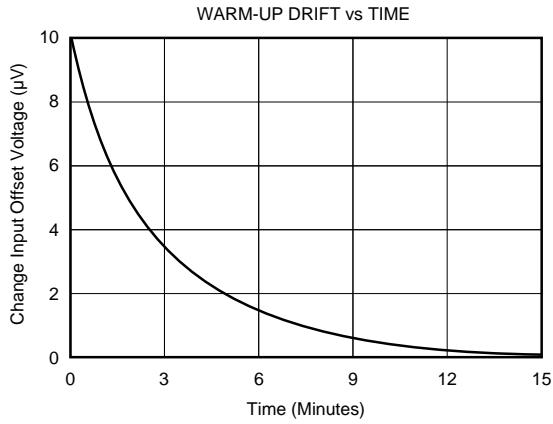

# DISCUSSION OF PERFORMANCE

## INSTRUMENTATION AMPLIFIERS

Instrumentation amplifiers are closed-loop gain blocks whose committed circuitry accurately amplifies the voltage applied to their inputs. They respond only to the difference between the two input signals and exhibit extremely high input impedance, both differentially and common-mode. Feedback networks are packaged within the amplifier module. Only one external gain setting resistor must be added. An operational amplifier, on the other hand, is an open-loop, uncommitted device that requires external networks to close the loop. While operational amplifiers can be used to achieve the same basic function as instrumentation amplifiers, it is difficult to reach the same level of performance. Using operational amplifiers often leads to design trade-offs when it is necessary to amplify low level signals in the presence of common-mode voltages while maintaining high input impedances.

### THE INA104

A simplified schematic of the INA104 is shown on the front pages of this data sheet. It is a three-amplifier device which provides all the desirable characteristics of a premium performance instrumentation amplifier. In addition, it has features not normally found on integrated circuit instrumentation amplifiers.

The input section ( $A_1$  and  $A_2$ ) incorporates high performance, low drift amplifier circuitry. The amplifiers are connected in the non-inverting configuration to provide the high input impedance ( $10^{10}\Omega$ ) desirable in the instrumentation amplifier function. The offset voltage and offset voltage versus temperature is low due to the monolithic design and improved even further by the state-of-the-art, laser-trimming techniques.

The output section ( $A_3$ ) is connected in a unity-gain difference amplifier configuration. A critical part of this stage is the matching of the four  $10k\Omega$  resistors which provide the difference function. These resistors must be initially well matched and the matching must be maintained over temperature and time in order to retain excellent common-mode rejection. (The  $106dB$  minimum at  $60Hz$  for gains greater than  $100V/V$  is a significant improvement compared to most other integrated circuit instrumentation amplifiers.)

All of the internal resistors are compatible, thin-film nichrome formed with the integrated circuit. The critical resistors are laser-trimmed to provide the desired high gain accuracy and common-mode rejection. Nichrome ensures long-term stability of trimmed resistors and excellent TCR and TCR tracking. This provides gain accuracy and common-mode rejection when the INA104 is operated over wide temperature ranges.

The fourth op amp ( $A_4$ ) of the INA104 adds a great deal of versatility and convenience to the amplifier. It allows easy implementation of active low-pass filtering, output offsetting, and additional gain generation. The pin connections make the use of this stage optional and the specifications appear separately in the table of Specifications.

### USING THE INA104

Figure 1 shows the simplest configuration of the INA104. The gain is set by the external resistor,  $R_G$ , with a gain equation of  $G = 1 + (40k/R_G)$ . The accuracy and TCR of  $R_G$  contribute directly to the gain accuracy and drift.

For gains greater than unity, resistor  $R_G$  is connected between pins 5 and 14. At high gains, where the value of  $R_G$  becomes small, additional resistance (i.e., relays, sockets) in series with  $R_G$  will contribute to gain error. Care should be taken to minimize this effect. However, this error can be virtually eliminated with the INA104 by using the Gain Sense circuit connection.

Pins 1, 5, 14, and 18 are accessible so that a four-terminal connection can be made to  $R_G$ . (Pins 1 and 18 are the voltage sense terminals, since no signal current flows into the operational amplifiers' inputs.) This is useful at high gains, where the value of  $R_G$  is small. The optional offset adjust capability is shown in Figure 1. The adjustment affects only the input stage component of the offset voltage. Thus, the null condition will be disturbed (if input offset is not adjusted to zero) when the gain is changed. Also, the input drift will be affected by approximately  $0.31\mu V/^\circ C$  per  $100\mu V$  of input offset voltage that is trimmed. Therefore, care should be taken when considering use of the control for removal of other sources of offset.

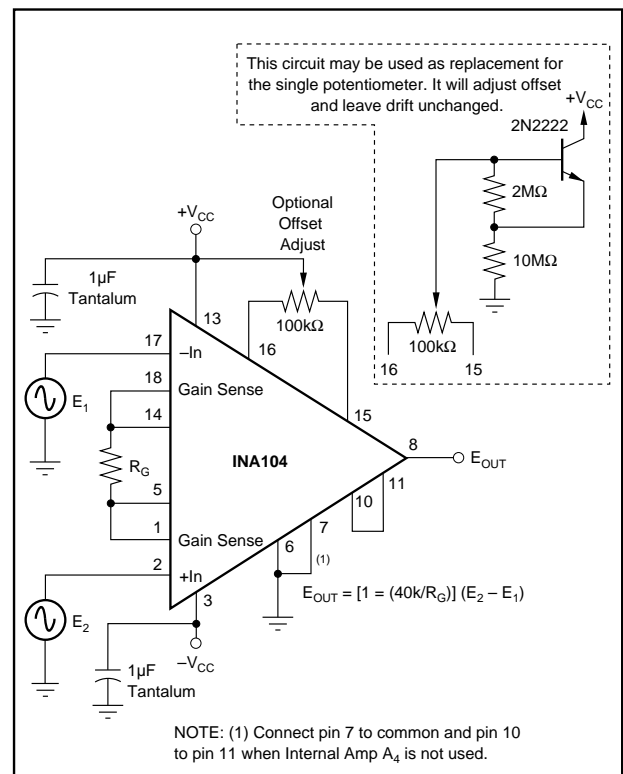

FIGURE 1. Basic Connection for the INA104 Including Optional Input Offset Null Potentiometer.

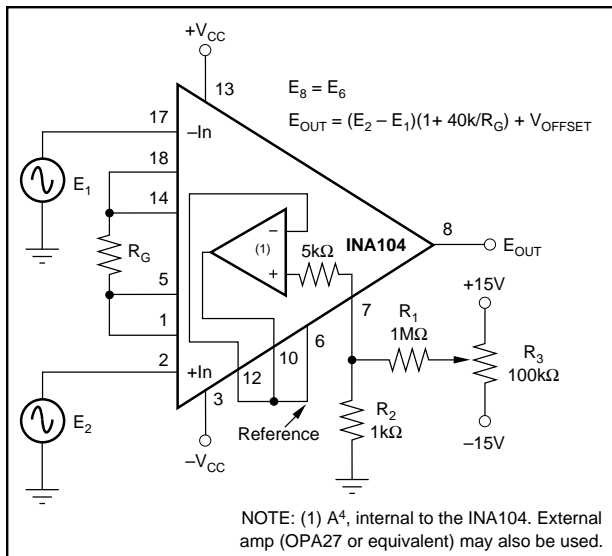

FIGURE 2. Optional Output Offset Nulling or Offsetting Using an Amplifier (Low Impedance to Pin 6).

### OPTIONAL OFFSET ADJUSTMENT PROCEDURE

It is frequently desirable to null the input component of offset (Figure 1) and occasionally that of the output (Figure 2). The quality of the potentiometer will affect the results, therefore, choose one with good temperature and mechanical-resistance stability. The procedure is as follows:

1. Set  $E_1 = E_2 = 0V$  (be sure a good ground return path exists to the input).
2. Set the gain to the desired value (greater than 1) by choosing  $R_G$ .
3. Adjust the 100kΩ potentiometer in Figure 1 until the output reads  $0V \pm 1mV$  or desired setting. Note that the offset will change when the gain is changed.
4. If the output component of offset is to be removed or if it is desired to establish an intentional offset, adjust the 100kΩ potentiometer in Figure 2 until the output reads  $0V \pm 1mV$  or desired setting. Note that the offset will not change with gain, but be sure to use a stable amplifier with good DC characteristics. The range of adjustment is  $\pm 15mV$  as shown. For larger ranges, change the ratio of  $R_1$  to  $R_2$ . The op amp is used to maintain a low resistance ( $<0.1\Omega$ ) from pin 6 to Common to avoid CMR degradation.

### BASIC CIRCUIT CONNECTION

The basic circuit connection for the INA104 is shown in Figure 1. The output voltage is a function of the differential input voltage times the gain. Figure 1 does not include additional internal op amp  $A_4$ . Power supply bypassing with a  $1\mu F$  tantalum capacitor or equivalent is always recommended.

In applications which do not use the fourth internal amplifier ( $A_4$ —pins 7, 9, 10, 11, and 12), pin 7 should be connected to Common and pins 10 and 11 should be connected together. This will prevent the output of  $A_4$  from saturating (“locking-up”) and affecting the offset of the instrumentation amplifier,  $A_1$ ,  $A_2$ , and  $A_3$ .

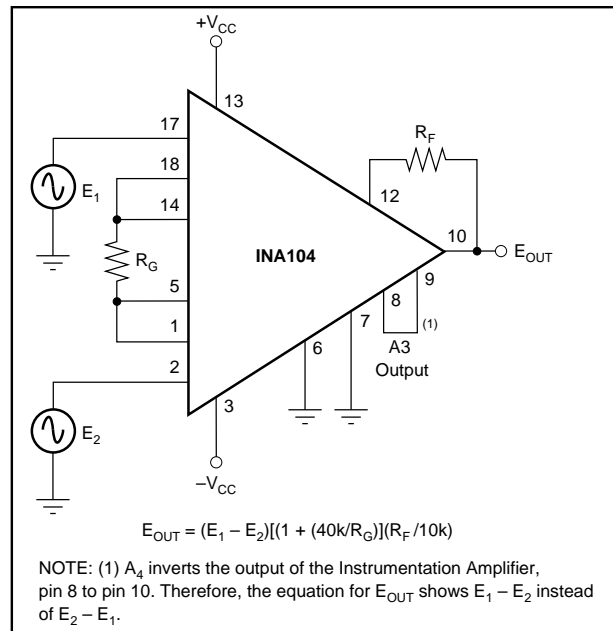

FIGURE 3. Additional Gain From Output Stage.

## TYPICAL APPLICATIONS

Many applications of instrumentation amplifiers involve the amplification of low-level differential signals from bridges and transducers such as strain gages, thermocouples, and RTDs. Some of the important parameters include common-mode rejection (differential cancellation of common-mode offset and noise), input impedance, offset voltage and drift, gain accuracy, linearity, and noise. The INA104 accomplishes all of these with high precision.

Figure 3 shows how the output stage may be used to provide additional gain. If gains greater than 1000V/V (10,000 up to 100,000 and greater) are desired, it is better to place some gain in the output amplifier rather than the input stage due

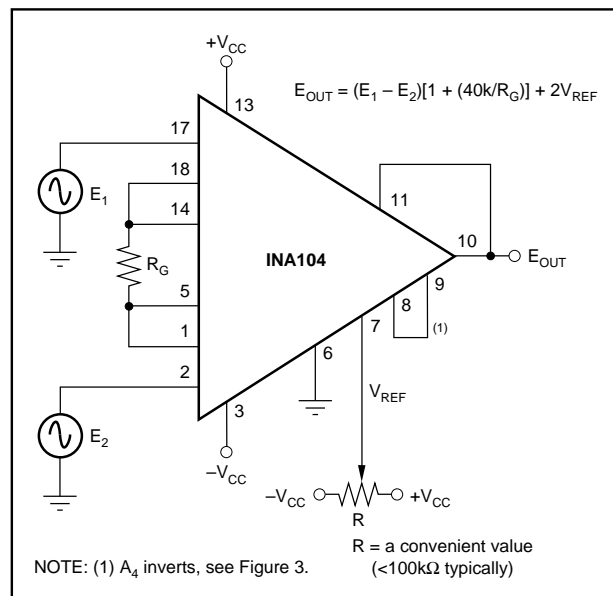

FIGURE 4. Output Offsetting.



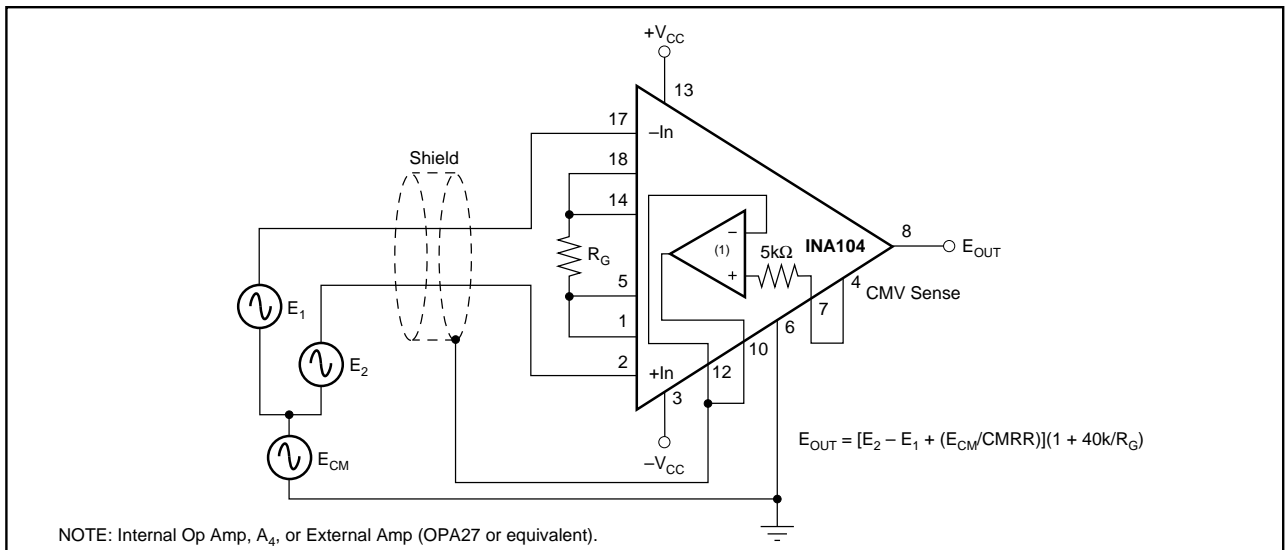

FIGURE 5. Use of Guard Drive.

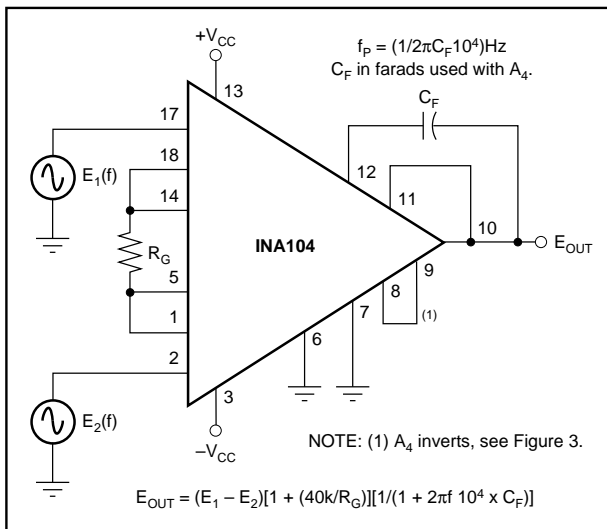

FIGURE 6. Active Low-Pass Filtering.

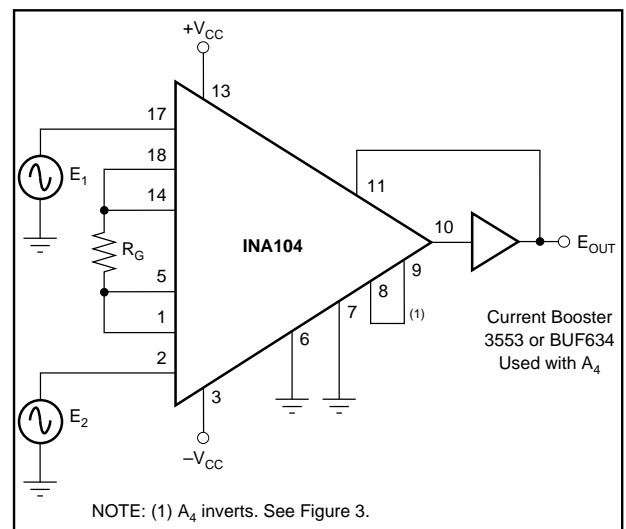

FIGURE 7. Output Power Boosting.

to the low values of  $R_G$  required ( $R_G < 40\Omega$  for  $(1 + 40k/R_G) > 1000$ ). Note, however, that accuracy can degrade due to high amplification of offset, drift, and noise errors.

Output offsetting (“zero suppression” or “zero elevation”) may be more easily accomplished with the INA104 than with most other IC instrumentation amplifiers as shown in Figure 4. The use of the extra internal op amp, A<sub>4</sub>, means that CMR of the instrumentation amp is not disturbed, and that a convenient value of variable resistor can be used. The circuit shown in Figure 2 can also be used to achieve the desired offsetting by scaling the resistors  $R_1$  and  $R_2$ . A low impedance path from pin 6 to Common should be provided to achieve the high CMR specified. Resistance above  $0.1\Omega$  will cause the CMR to fall below 106dB.

Amplifier A<sub>4</sub> also allows active low-pass filtering to be implemented conveniently with a single capacitor. Filtering can be used for noise reduction or band-limiting of the output signal as shown in Figure 6.

The common-mode voltage from the 26k $\Omega$  resistors in the input section appears at pin 4. Figure 5 shows how this voltage can be used to drive the shield of the input cable. Since the cable is driven at the common-mode voltage, the effects of distributed capacitance is reduced and the AC system common-mode rejection may be improved. Amplifier A<sub>4</sub> buffers the CMV at pin 4 from the input cable.

Some typical application circuits are shown in Figures 9 through 11.

## GENERAL RECOMMENDED HANDLING PROCEDURES FOR INTEGRATED CIRCUITS

All semiconductor devices are vulnerable, in varying degrees, to damage from the discharge of electrostatic energy. Such damaging can cause performance degradation or failure, either immediate or latent. As a general practice, we recommend the following handling procedures to reduce the risk of electrostatic damage.

1. Remove static-generating materials, such as untested plastics, from all areas that handle microcircuits.

2. Ground all operators, equipment, and work stations.

3. Transport and ship microcircuits, or products incorporating microcircuits, in static-free, shielded containers.

4. Connect together all leads of each device by means of a conductive material, when the device is not connected into a circuit.

5. Control relative humidity to as high a value as practical (50% is recommended).

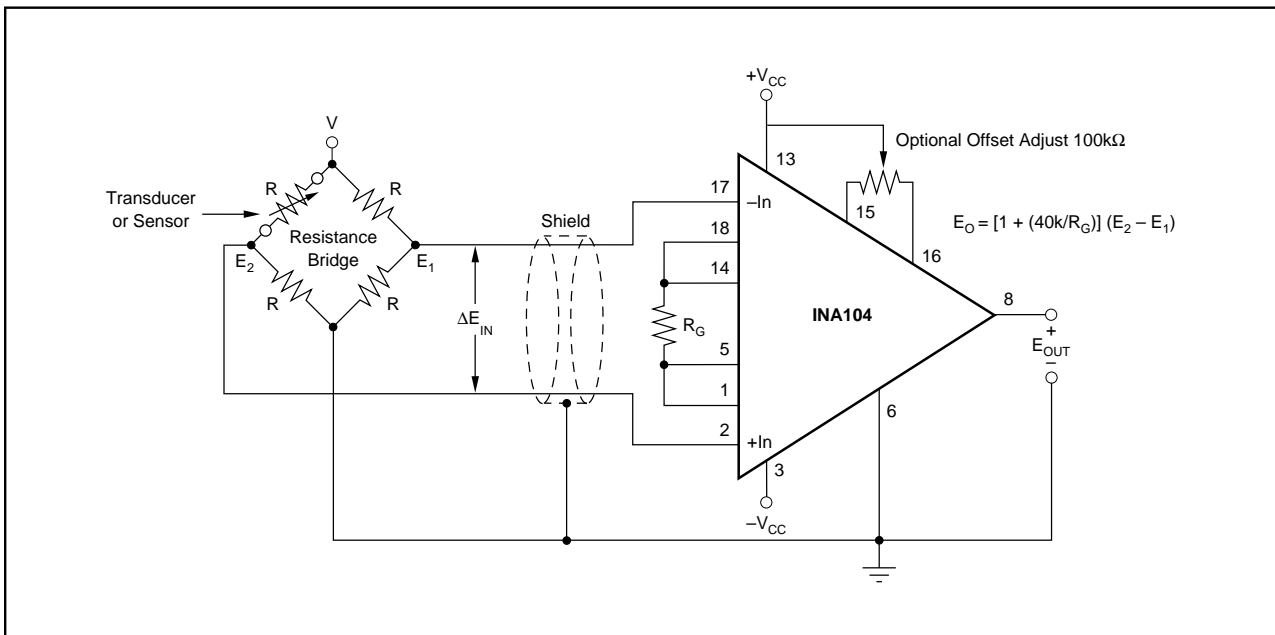

FIGURE 8. Amplification of a Differential Voltage From a Resistance Bridge.

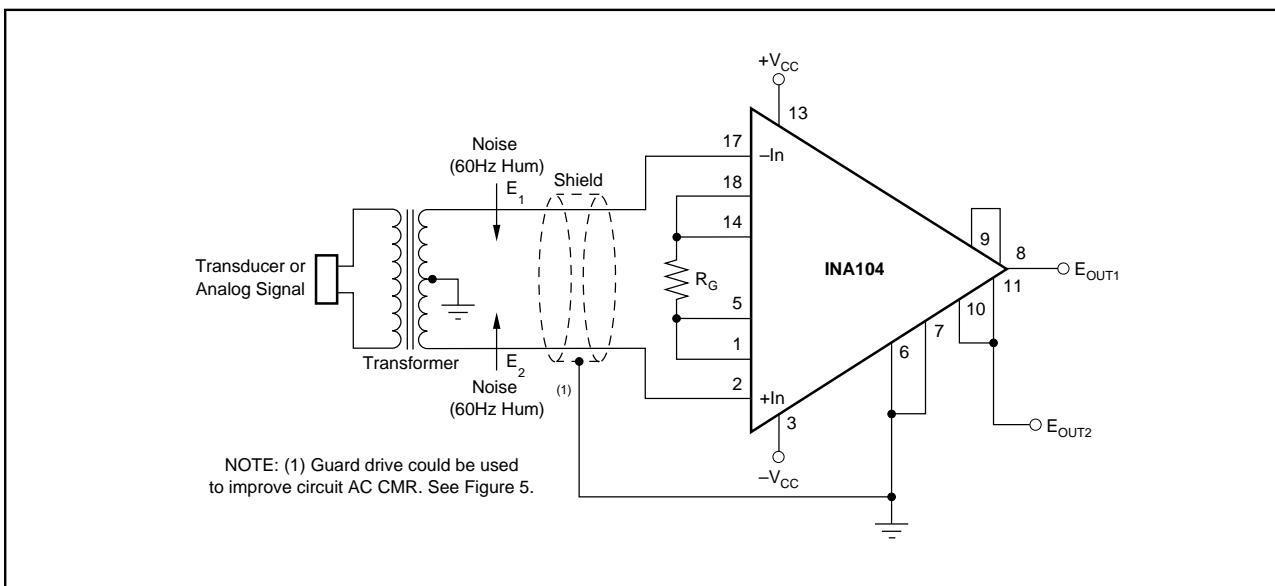

FIGURE 9. Amplification of a Transformer Coupled Analog Signal.

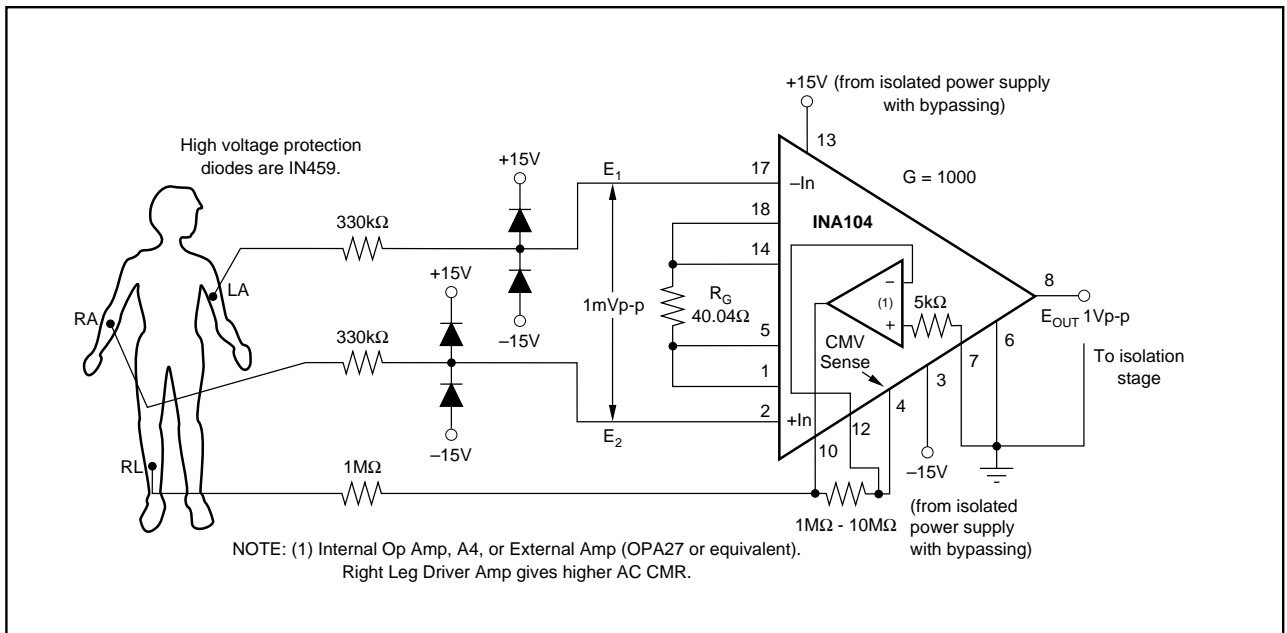

FIGURE 10. ECG Amplifier or Recorder Pre-Amp for Biological Signals.

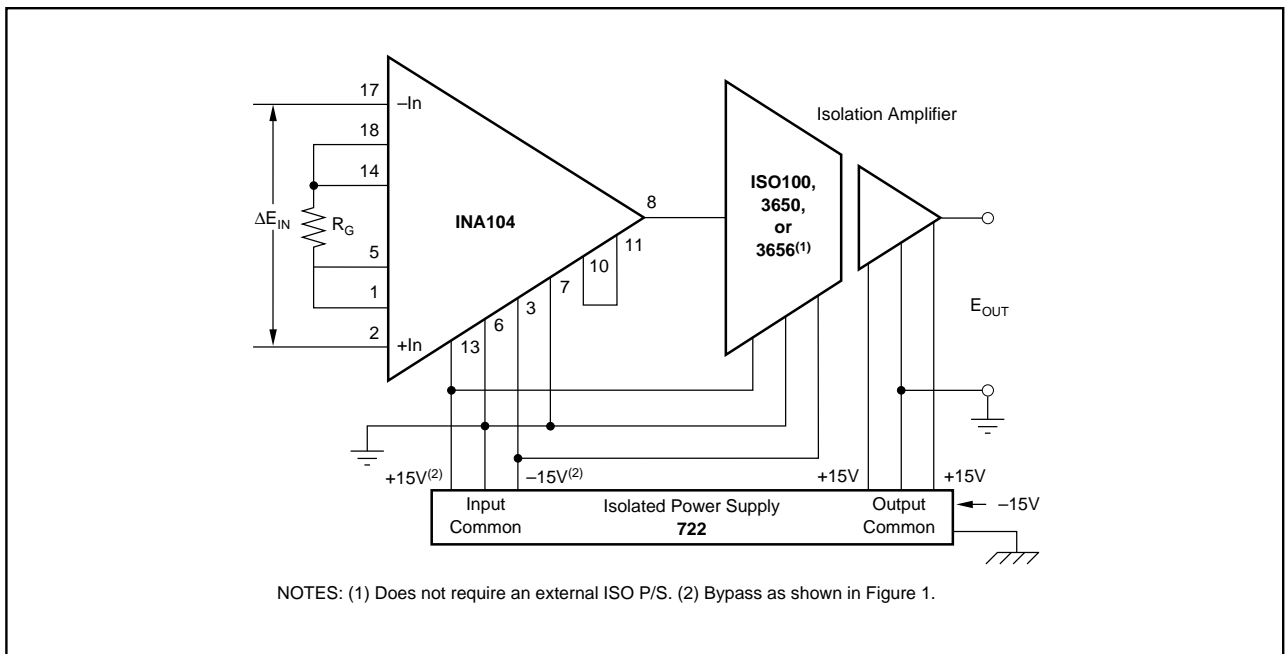

FIGURE 11. Precision Isolated Instrumentation Amplifier.