

**Low Cost, Dual, Triple and Quad Video Op Amps**



This family of dual, triple, and quad operational amplifiers built using Elantec's Complementary Bipolar

process offers unprecedented high frequency performance at a very low cost. They are suitable for any application such as consumer video, where traditional DC performance specifications are of secondary importance to the high frequency specifications. On  $\pm 5V$  supplies at a gain of +1 the EL2210, EL2310, and EL2410 will drive a  $150\Omega$  load to +2V, -1V with a bandwidth of 50MHz and a channel-to-channel isolation of 60dB or more. At a gain of +2, the EL2211, EL2311, and EL2411 will drive a  $150\Omega$  load to +2V, -1V with a bandwidth of 100MHz with the same channel-to-channel isolation. All four achieve 0.1dB bandwidth at 5MHz.

The power supply operating range is fixed at  $\pm 5V$  or +10/0V. In single supply operation the inputs and outputs will operate to ground. Each amplifier draws only 7mA of supply current.

**Features**

- Stable at gain of 2 and 100MHz gain\_bandwidth product (EL2211, EL2311, & EL2411)
- Stable at gain of 1 and 50MHz gain\_bandwidth product (EL2210, EL2310, & EL2410)
- 130V/ $\mu s$  slew rate
- Drives  $150\Omega$  load to video levels
- Inputs and outputs operate at negative supply rail
- $\pm 5V$  or +10V supplies
- -60dB isolation at 4.2MHz

**Applications**

- Consumer video amplifiers
- Active filters/integrators
- Cost-sensitive application
- Single supply amplifiers

**Ordering Information**

PART NUMBER	PACKAGE	TAPE & REEL	PKG. NO.
EL2210CN	8-Pin PDIP	-	MDP0031
EL2210CS	8-Pin SO	-	MDP0027
EL2210CS-T7	8-Pin SO	7"	MDP0027
EL2210CS-T13	8-Pin SO	13"	MDP0027
EL2211CN	8-Pin PDIP	-	MDP0031
EL2211CS	8-Pin SO	-	MDP0027
EL2310CN	8-Pin PDIP	-	MDP0031
EL2310CS	8-Pin SO	-	MDP0027
EL2311CN	8-Pin PDIP	-	MDP0031
EL2311CS	8-Pin SO	-	MDP0027
EL2410CN	14-Pin PDIP	-	MDP0031
EL2410CS	14-Pin SO	-	MDP0027
EL2410CS-T7	14-Pin SO	7"	MDP0027
EL2410CS-T13	14-Pin SO	13"	MDP0027
EL2411CN	14-Pin PDIP	-	MDP0031
EL2411CS	14-Pin SO	-	MDP0027

Pinouts

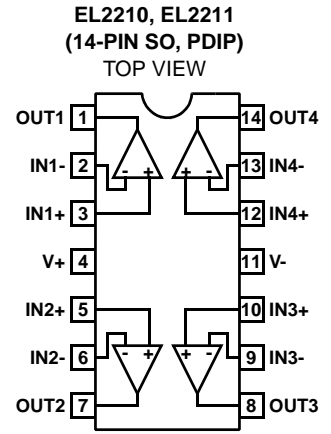
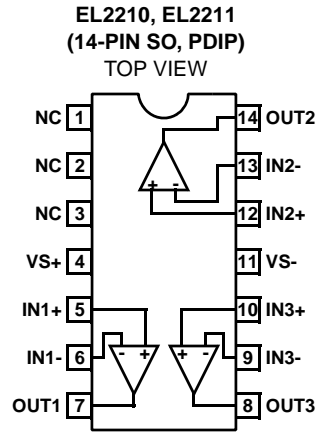
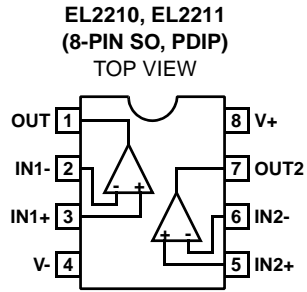

## EL2210/11, EL2310/11, EL2410/11

### Absolute Maximum Ratings ( $T_A = 25^\circ\text{C}$ )

Total Voltage Supply	18V
Input Voltage	$\pm V_S$
Differential Input Voltage	6V
Peak Output Current	75mA (per amplifier)

Power Dissipation	See Curves
Storage Temperature Range	-65°C to +150°C
Operating Temperature Range	-40°C to +85°C
Die Junction Temperature	+150°C

**CAUTION:** Stresses above those listed in "Absolute Maximum Ratings" may cause permanent damage to the device. This is a stress only rating and operation of the device at these or any other conditions above those indicated in the operational sections of this specification is not implied.

**IMPORTANT NOTE:** All parameters having Min/Max specifications are guaranteed. Typical values are for information purposes only. Unless otherwise noted, all tests are at the specified temperature and are pulsed tests, therefore:  $T_J = T_C = T_A$

### EL2210, EL2310, EL2410 - DC Electrical Specifications $V_S = \pm 5\text{V}$ , $R_L = 1\text{k}\Omega$ , $T_A = 25^\circ\text{C}$ unless otherwise noted.

PARAMETER	DESCRIPTION	CONDITIONS	MIN	TYP	MAX	UNIT
V <sub>OS</sub>	Input Offset Voltage			10	20	mV
		EL2310 only		10	25	mV
		EL2311 only		5	25	mV
TCV <sub>OS</sub>	Average Offset Voltage Drift (Note 1)			-25		$\mu\text{V}/^\circ\text{C}$
I <sub>B</sub>	Input Bias Current		-15	-7	-3	$\mu\text{A}$
I <sub>OS</sub>	Input Offset Current			0.5	1.5	$\mu\text{A}$
TCI <sub>OS</sub>	Average Offset Current Drift (Note 1)			-7		nA/°C
A <sub>VOL</sub>	Open-Loop Gain	V <sub>OUT</sub> = $\pm 2\text{V}$ , R <sub>L</sub> = 1k $\Omega$	160	250		V/V
		V <sub>OUT</sub> = +2V/0V, R <sub>L</sub> = 150 $\Omega$	160	250		
PSRR	Power Supply Rejection	V <sub>S</sub> = $\pm 4.5\text{V}$ to $\pm 5.5\text{V}$	50	60		dB
CMRR	Common Mode Rejection	V <sub>CM</sub> = $\pm 2.4\text{V}$ , V <sub>OUT</sub> = 0V	60	80		dB
CMIR	Common Mode Input Range	V <sub>S</sub> = $\pm 5\text{V}$		-5/+3		V
V <sub>OUT</sub>	Output Voltage Swing	R <sub>L</sub> = R <sub>F</sub> = 1k $\Omega$ R <sub>L</sub> to GND	-2.5	-3, 3	2.7	V
		R <sub>L</sub> = R <sub>F</sub> = 1k $\Omega$ +150 $\Omega$ to GND	-0.45	-0.6, 2.9	2.5	
		R <sub>L</sub> = R <sub>F</sub> = 1k $\Omega$ R <sub>L</sub> to V <sub>EE</sub>	-4.95		3	
I <sub>SC</sub>	Output Short Circuit Current	Output to GND (Note 1)	75	125		mA
I <sub>S</sub>	Supply Current	No Load (per channel)	5.5	6.8	10	mA
R <sub>IN</sub>	Input Resistance	Differential		150		k $\Omega$
		Common Mode		1.5		M $\Omega$
C <sub>IN</sub>	Input Capacitance	A <sub>V</sub> = +1 @ 10MHz		1		pF
R <sub>OUT</sub>	Output Resistance			0.150		$\Omega$
PSOR	Power Supply Operating Range	Dual Supply	$\pm 4.5$		$\pm 6.5$	V
		Single Supply	9		13	

NOTE:

1. A heat sink is required to keep junction temperature below absolute maximum when an output is shorted.

## EL2210/11, EL2310/11, EL2410/11

### EL2211, EL2311, EL2411 - DC Electrical Characteristics $V_S = \pm 5V$ , $R_L = 1k\Omega$ , $A_V = +2$ , $T_A = 25^\circ C$ unless otherwise noted.

PARAMETER	DESCRIPTION	CONDITIONS	MIN	TYP	MAX	UNIT
$V_{OS}$	Input Offset Voltage			5	12	mV
$TCV_{OS}$	Average Offset Voltage Drift (Note 1)			-25		$\mu V/^\circ C$
$I_B$	Input Bias Current		-15	-7	-3	$\mu A$
$I_{OS}$	Input Offset Current			0.5	1.5	$\mu A$
$TCI_{OS}$	Average Offset Current Drift (Note 1)			-7		$nA/^\circ C$
$A_{VOL}$	Open-Loop Gain	$V_{OUT} = \pm 2V$ , $R_L = 1k\Omega$	250	380		V/V
		$V_{OUT} = +2V/0V$ , $R_L = 150\Omega$	250	380		
PSRR	Power Supply Rejection	$V_S = \pm 4.5V$ to $\pm 5.5V$	55	68		dB
CMRR	Common Mode Rejection	$V_{CM} = \pm 2.5V$ , $V_{OUT} = 0V$	70	90		dB
CMIR	Common Mode Input Range	$V_S = \pm 5V$		-5/+3		V
$V_{OUT}$	Output Voltage Swing	$R_L = R_F = 1k\Omega$ $R_L$ to GND	2.5	-3.5, 3.3	2.7	V
		$R_L = R_F = 1k\Omega + 150\Omega$ to GND	-0.45	-0.6, 2.9	2.5	
		$R_L = R_F = 1k\Omega$ $R_L$ to $V_{EE}$	-4.95		3	
$I_{SC}$	Output Short Circuit Current	Output to GND (Note 1)	75	125		mA
$I_S$	Supply Current	No Load	5.5	6.8	10	mA
$R_{IN}$	Input Resistance	Differential		150		$k\Omega$
		Common Mode		1.5		$M\Omega$
$C_{IN}$	Input Capacitance	$A_V = +1$ @ 10MHz		1		pF
$R_{OUT}$	Output Resistance			0.150		$\Omega$
PSOR	Power Supply Operating Range	Dual Supply	$\pm 4.5$		$\pm 6.5$	V
		Single Supply	9		13	

**NOTE:**

1. A heat-sink is required to keep junction temperature below absolute maximum when an output is shorted

### EL2210, EL2310, EL2410 - Closed-Loop AC Characteristics $V_S = \pm 5V$ , AC Test Figure 1, $T_A = 25^\circ C$ unless otherwise noted.

PARAMETER	DESCRIPTION	CONDITIONS	MIN	TYP	MAX	UNIT
BW	-3dB Bandwidth ( $V_{OUT} = 0.4V_{PP}$ )	$A_V = +1$		110		MHz
BW	$\pm 0.1$ dB Bandwidth ( $V_{OUT} = 0.4V_{PP}$ )	$A_V = +1$		12		MHz
GBWP	Gain Bandwidth Product			55		MHz
PM	Phase Margin			60		$^\circ C$
SR	Slew Rate		85	130		V/ $\mu s$
FBWP	Full Power Bandwidth (Note 1)		8	11		MHz
$t_R, t_F$	Rise Time, Fall Time	0.1V Step		2		ns
OS	Overshoot	0.1V Step		15		%
$t_{PD}$	Propagation Delay			3.5		ns
$t_S$	Settling to 0.1% ( $A_V = 1$ )	$V_S = \pm 5V$ , 2V Step		80		ns
$d_G$	Differential Gain (Note 2)	NTSC/PAL		0.1		%
$d_P$	Differential Phase (Note 2)	NTSC/PAL		0.2		$^\circ C$
$e_N$	Input Noise Voltage	10kHz		15		nV/ $\sqrt{Hz}$
$i_N$	Input Noise Current	10kHz		1.5		pA/ $\sqrt{Hz}$

## EL2210/11, EL2310/11, EL2410/11

### EL2210, EL2310, EL2410 - Closed-Loop AC Characteristics $V_S = \pm 5V$ , AC Test Figure 1, $T_A = 25^\circ C$ unless otherwise noted.

PARAMETER	DESCRIPTION	CONDITIONS	MIN	TYP	MAX	UNIT
CS	Channel Separation	P = 5MHz		55		dB

**NOTES:**

- For  $V_S = \pm 5V$ ,  $V_{OUT} = 4 V_{PP}$  Full power bandwidth is based on slew rate measurement using:  $FPBW = SR / (2\pi * V_{peak})$
- Video performance measured at  $V_S = \pm 5V$ ,  $A_V = +2$  with 2 times normal video level across  $R_L = 150\Omega$

### EL2211, EL2311, EL2411 - Closed-Loop AC Characteristics $V_S = \pm 5V$ , AC Test Figure 1, $T_A = 25^\circ C$ unless otherwise noted.

PARAMETER	DESCRIPTION	CONDITIONS	MIN	TYP	MAX	UNIT
BW	-3dB Bandwidth ( $V_{OUT} = 0.4V_{PP}$ )	$A_V = +2$		100		MHz
BW	$\pm 0.1dB$ Bandwidth ( $V_{OUT} = 0.4V_{PP}$ )	$A_V = +2$		8		MHz
GBWP	Gain Bandwidth Product			130		MHz
PM	Phase Margin			60		$^\circ C$
SR	Slew Rate		100	140		V/ $\mu s$
FBWP	Full Power Bandwidth (Note 1)		8	11		MHz
$t_R, t_F$	Rise Time, Fall Time	0.1V Step		2.5		ns
OS	Overshoot	0.1V Step		6		%
$t_{PD}$	Propagation Delay			3.5		ns
$t_S$	Settling to 0.1% ( $A_V = 1$ )	$V_S = \pm 5V$ , 2V Step		80		ns
$d_G$	Differential Gain (Note 2)	NTSC/PAL		0.04		%
$d_P$	Differential Phase (Note 2)	NTSC/PAL		0.15		$^\circ C$
$e_N$	Input Noise Voltage	10kHz		15		nV/ $\sqrt{Hz}$
$i_N$	Input Noise Current	10kHz		1.5		pA/ $\sqrt{Hz}$
CS	Channel Separation	P = 5MHz		55		dB

**NOTES:**

- For  $V_S = \pm 5V$ ,  $V_{OUT} = 4 V_{PP}$  Full power bandwidth is based on slew rate measurement using:  $FPBW = SR / (2\pi * V_{peak})$
- Video performance measured at  $V_S = \pm 5V$ ,  $A_V = +2$  with 2 times normal video level across  $R_L = 150\Omega$ .

### Simplified Block Diagram

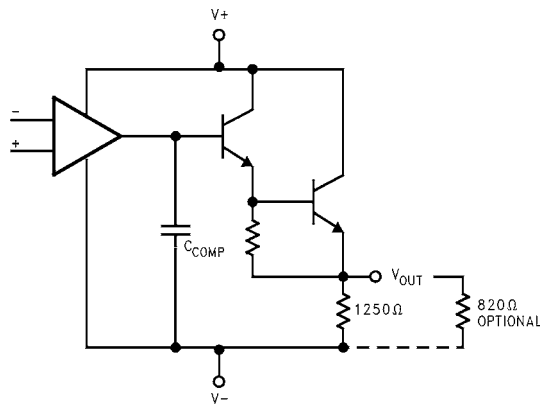

## Typical Performance Curves

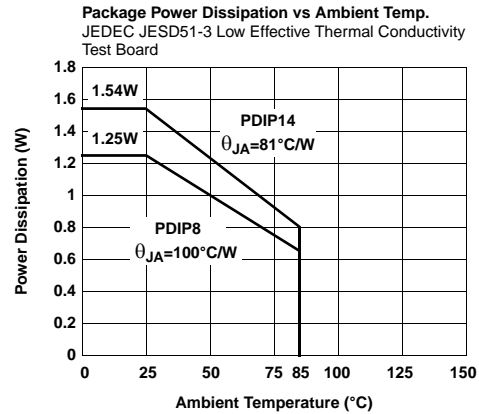
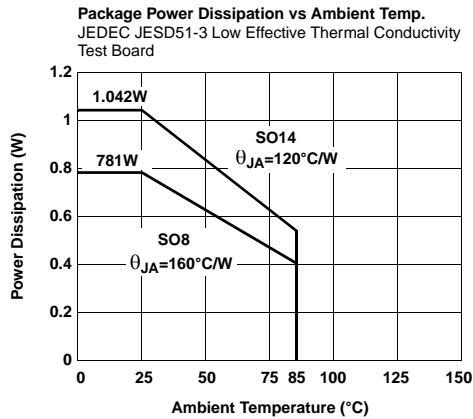

## Application Information

### Product Description

The EL2210, EL2310, and EL2410 are dual, triple, and quad operational amplifiers stable at a gain of 1. The EL2211, EL2311, and EL2411 are dual, triple, and quad operational amplifiers stable at a gain of 2. All six are built on Elantec's proprietary complimentary process and share the same voltage mode feedback topology. This topology allows them to be used in a variety of applications where current mode feedback amplifiers are not appropriate because of restrictions placed on the feedback elements. These products are especially designed for applications where high bandwidth and good video performance characteristics are desired but the higher cost of more flexible and sophisticated products are prohibitive.

### Power Supplies

These amplifiers are designed to work at a supply voltage difference of 10V to 12V. These amplifiers will work on any combination of  $\pm$  supplies. All electrical characteristics are measured with  $\pm 5V$  supplies. Below 9V total supply voltage the amplifiers' performance will degrade dramatically. The quiescent current is a direct function of total supply voltage. With a total supply voltage of 12V the quiescent supply current will increase from a typical 6.8mA per amplifier to 10mA per amplifier.

### Output Swing vs Load

Please refer to the simplified block diagram. These amplifiers provide an NPN pull-up transistor output and a passive 1250 $\Omega$  pull-down resistor to the most negative supply. In an application where the load is connected to  $V_{S-}$  the output voltage can swing to within 200mV of  $V_{S-}$ . In split supply applications where the DC load is connected to ground the negative swing is limited by the voltage divider formed by the load, the internal 1250 $\Omega$  resistor and any external pull-down

resistor. If  $R_L$  were 150 $\Omega$  then it and the 1250 $\Omega$  internal resistor limit the maximum negative swing to

$$V_{EE} = \frac{150}{1250 + 150}$$

Or -0.53V

The negative swing can be increased by adding an external resistor of appropriate value from the output to the negative supply. The simplified block diagram shows an 820 $\Omega$  external pull-down resistor. This resistor is in parallel with the internal 1250 $\Omega$  resistor. This will increase the negative swing to

$$V_{EE} = 150 \div \frac{1250 \times 820}{1250 + 820} + 150$$

Or -1.16V

### Power Dissipation and Loading

Without any load and a 10V supply difference the power dissipation is 70mW per amplifier. At 12V supply difference this increases to 105mW per amplifier. At 12V this translates to a junction temperature rise above ambient of 33 $^{\circ}C$  for the dual and 40 $^{\circ}C$  for the quad amplifier. When the amplifiers provide load current the power dissipation can rapidly rise.

In  $\pm 5V$  operation each output can drive a grounded 150 $\Omega$  load to more than 2V. This operating condition will not exceed the maximum junction temperature limit as long as the ambient temperature is below 85 $^{\circ}C$ , the device is soldered in place, and the extra pull-down resistor is 820 $\Omega$  or more.

If the load is connected to the most negative voltage (ground in single supply operation) you can easily exceed the absolute maximum die temperature. For example the maximum die temperature should be 150 $^{\circ}C$ . At a maximum

expected ambient temperature of 85°C, the total allowable power dissipation for the SO8 package would be:

$$P_D = \frac{150 - 85}{160^\circ\text{C/W}} = 361\text{mW}$$

At 12V total supply voltage each amplifier draws a maximum of 10mA and dissipates  $12\text{V} * 10\text{mA} = 120\text{mW}$  or  $240\text{mW}$  for the dual amplifier. Which leaves  $121\text{mW}$  of increased power due to the load. If the load were  $150\Omega$  connected to the most negative voltage and the maximum voltage out were  $V_S - +1\text{V}$  the load current would be  $6.67\text{mA}$ . Then an extra  $146\text{mW} ((12\text{V} - 1\text{V}) * 6.67\text{mA} * 2)$  would be dissipated in the EL2210 or EL2211. The total dual amplifier power dissipation would be  $146\text{mW} + 240\text{mW} = 386\text{mW}$ , more than the maximum  $361\text{mW}$  allowed. If the total supply difference were reduced to 10V, the same calculations would yield  $200\text{mW}$  quiescent power dissipation and  $120\text{mW}$  due to loading. This results in a die temperature of  $143^\circ\text{C}$  ( $85^\circ\text{C} + 58^\circ\text{C}$ ).

In the above example, if the supplies were split  $\pm 6\text{V}$  and the  $150\Omega$  loads were connected to ground, the load induced power dissipation would drop to  $66.7\text{mW}$  ( $6.67\text{mA} * (6 - 1) * 2$ ) and the die temperature would be below the rated maximum.

### Video Performance

Following industry standard practices (see EL2044 applications section) these six devices exhibit good differential gain (dG) and good differential phase (dP) with  $\pm 5\text{V}$  supplies and an external  $820\Omega$  resistor to the negative supply, in a gain of 2 configuration. Driving  $75\Omega$  back terminated cables to standard video levels ( $1.428\text{V}$  at the amplifier) the EL2210, EL2310, and EL2410 have dG of 0.1% and dP of  $0.2^\circ$ . The EL2211, EL2311, and EL2411 have dG of 0.04% and dP of  $0.15^\circ$ .

Due to the negative swing limitations described above, inverted video at a gain of 2 is just not practical. If swings below ground are required then changing the extra  $820\Omega$  resistor to  $500\Omega$  will allow reasonable dG and dP to approximately  $-0.75\text{mV}$ . The EL2211, EL2311, and EL2411 will achieve approximately  $0.1\%/0.4^\circ$  between  $0\text{V}$  and  $-0.75\text{V}$ . Beyond  $-0.75\text{V}$  dG and dP get worse by orders of magnitude.

Differential gain and differential phase are fairly constant for all loads above  $150\Omega$ . Differential phase performance will improve by a factor of 3 if the supply voltage is increased to  $\pm 6\text{V}$ .

### Output Drive Capability

None of these devices have short circuit protection. Each output is capable of more than  $100\text{mA}$  into a shorted output. Care must be used in the design to limit the output current with a series resistor.

### Printed-Circuit Layout

The EL2210/EL2211/EL2310/EL2311/ EL2410/EL2411 are well behaved, and easy to apply in most applications. However, a few simple techniques will help assure rapid, high quality results. As with any high-frequency device, good PCB layout is necessary for optimum performance. Ground-plane construction is highly recommended, as is good power supply bypassing. A  $0.1\mu\text{F}$  ceramic capacitor is recommended for bypassing both supplies. Lead lengths should be as short as possible, and bypass capacitors should be as close to the device pins as possible. For good AC performance, parasitic capacitances should be kept to a minimum at both inputs and at the output. Resistor values should be kept under  $5\text{k}\Omega$  because of the RC time constants associated with the parasitic capacitance. Metal-film and carbon resistors are both acceptable, use of wire-wound resistors is not recommended because of their parasitic inductance. Similarly, capacitors should be low-inductance for best performance.

**EL2210/EL2310/EL2410 Macromodel**

\* Revision A, June 1994

\* Application Hints:

\*

\* A pull down resistor between the output and V- is recommended

\* to allow output voltages to swing close to V-. See datasheet

\* for recommended values.

\*

\* Connections:

	+In				
*		-In			
*			V+		
*				V-	
*					V <sub>out</sub>
*					

```
.subckt EL2210/EL 3 2 8 4 1
q1 20 3 24 qp
q2 21 2 25 qp
q3 10 10 26 qp
q4 12 10 11 qp
q5 14 10 13 qp
q6 19 19 20 qn
q7 14 19 21 qn
q8 8 14 15 qn
q9 8 16 17 qn 10
r1 24 12 350
r2 12 25 350
r3 8 26 250
r4 8 11 150
r5 8 13 240
r6 20 4 150
r7 21 4 150
r8 15 17 700
r9 1 4 1250
r10 15 16 40
r11 17 1 15
r12 10 19 10K
r13 14 22 20
c1 22 4 0.45pF
c2 22 19 1pF
d1 1 14 dcap
.model qn npn(bf=150 tf=0.05nS)
.model qp pnp(bf=90 tf=0.05nS)
.model dcap d(rs=200 cjo=1e-12 vj=0.8 tt=100e-9)
.ends
```



**EL2211/EL2311/EL2411 Macromodel** (Continued)

\* Revision A, June 1994

\* Application Hints:

\*

\* A pull down resistor between the output and V- is recommended

\* to allow output voltages to swing close to V-. See datasheet

\* for recommended values.

\*

\* Connections:

+	In	-	In	V+	V-	V <sub>out</sub>

```
.subckt EL2211/EL 3 2 8 4 1
q1 20 3 24 qp
q2 21 2 25 qp
q3 10 10 26 qp
q4 12 10 11 qp
q5 14 10 13 qp
q6 19 19 20 qn
q7 14 19 21 qn
q8 8 14 15 qn
q9 8 16 17 qn 10
r1 24 12 175
r2 12 25 175
r3 8 26 250
r4 8 11 150
r5 8 13 240
r6 20 4 150
r7 21 4 150
r8 15 17 700
r9 1 4 1250
r10 15 16 40
r11 17 1 15
r12 10 19 10K
r13 14 22 20
c1 22 4 0.42pF
c2 22 19 1pF
d1 1 14 dcap
.model qn npn(bf=150 tf=0.05nS)
.model qp pnp(bf=90 tf=0.05nS)
.model dcap d(rs=200 cjo=1e-12 vj=0.8 tt=100e-9)
.ends
```

EL2211/EL2311/EL2411 Macromodel (Continued)

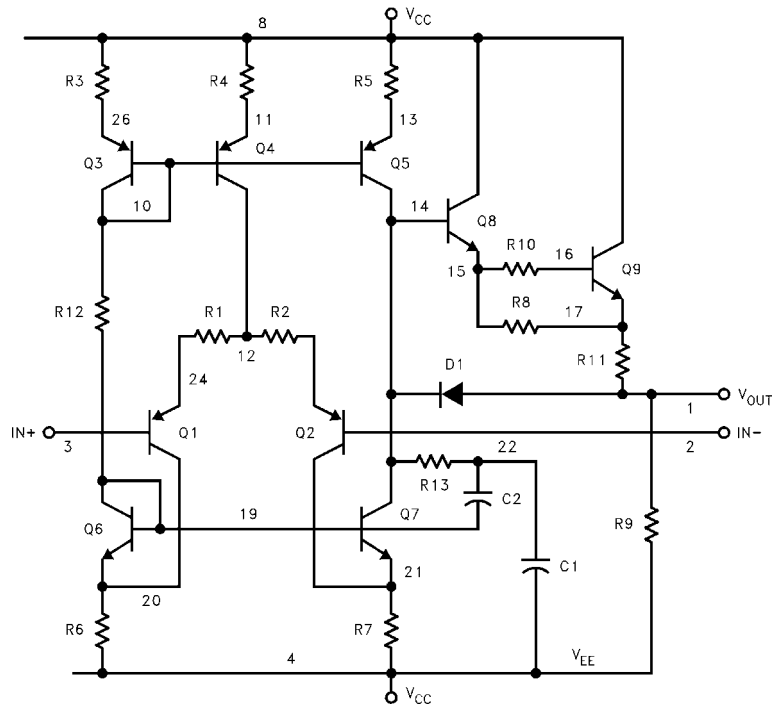

All Intersil U.S. products are manufactured, assembled and tested utilizing ISO9000 quality systems.  
 Intersil Corporation's quality certifications can be viewed at [www.intersil.com/design/quality](http://www.intersil.com/design/quality)

*Intersil products are sold by description only. Intersil Corporation reserves the right to make changes in circuit design, software and/or specifications at any time without notice. Accordingly, the reader is cautioned to verify that data sheets are current before placing orders. Information furnished by Intersil is believed to be accurate and reliable. However, no responsibility is assumed by Intersil or its subsidiaries for its use; nor for any infringements of patents or other rights of third parties which may result from its use. No license is granted by implication or otherwise under any patent or patent rights of Intersil or its subsidiaries.*

For information regarding Intersil Corporation and its products, see [www.intersil.com](http://www.intersil.com)

