

SURFACE MOUNT 1.5 AMP HIGH VOLTAGE POSITIVE AND NEGATIVE ADJUSTABLE REGULATOR

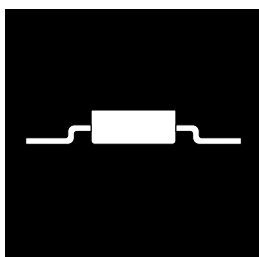

Dual Positive And Negative Adjustable High Voltage Regulators In Isolated Hermetic Surface Mount Package

FEATURES

- Similar To Industry Standard LT117AHV And LT137AHV
- Adjustable Output Voltage
- Built In Thermal Overload Protection
- Short Circuit Current Limiting
- Hermetic 6-Pin Metal Surface Mount Package
- Maximum Output Voltage Tolerance Is Guaranteed To $\pm 1\%$
- Available Hi-Rel Screened

DESCRIPTION

This device offers a positive and negative adjustable regulator in one hermetically sealed 6-pin surface mount package. All protective features are designed into the circuit, including thermal shutdown, current limiting, and safe-area control. With heat sinking, these devices can deliver up to 1.5 amps of output current. This device is ideally suited for military applications where small size and high reliability is required.

ABSOLUTE MAXIMUM RATINGS

Input - Output Voltage Differential - LT117AHV Positive Regulator	+ 60 V
Input - Output Voltage Differential - LT137AHV Negative Regulator	- 50 V
Power Dissipation (P_d) (Internally Limited)	20 W
Operating Junction Temperature Range	- 55°C to + 150°C
Storage Temperature Range	- 65°C to + 150°C
Lead Temperature (Soldering 10 seconds)	300°C
Thermal Resistance:	
θ_{JC}	4.2°C/W
θ_{JA}	42°C/W
Maximum Output Current	1.5 A

MECHANICAL OUTLINE

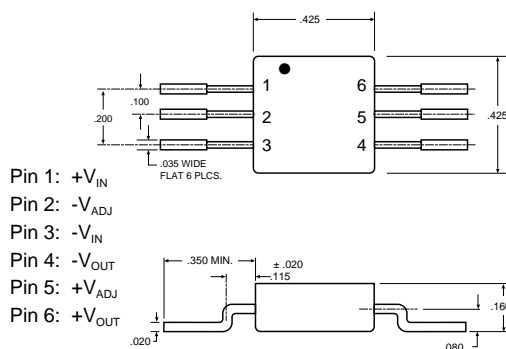

NOTES:

- Case is metal/hermetically sealed
- Isolated Tab

DUAL TRACKING SUPPLY $\pm 1.25V$ TO $\pm 20V$

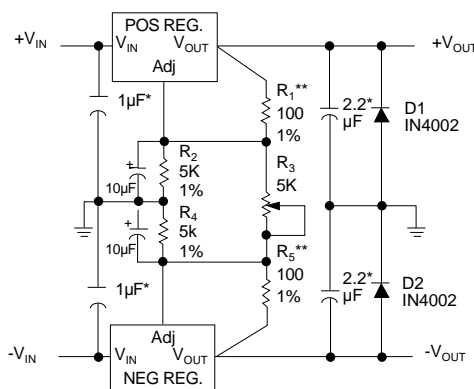

- * Solid Tantalum
- ** R_1 or R_2 may be trimmed slightly to improve tracking.

3.5

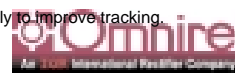

ELECTRICAL CHARACTERISTICS Positive Regulator -55°C T_A 125°C, I_L = 8mA (unless otherwise specified)

Parameter	Symbol	Test Conditions	Min.	Max.	Unit
Reference Voltage	V _{REF}	V _{DIFF} = 3.0V, T _A = 25°C V _{DIFF} = 3.3V V _{DIFF} = 40V V _{DIFF} = 60V	• 1.238 • 1.225 • 1.225 • 1.225	1.262 1.270 1.270 1.270	V
Line Regulation (Note 1)	R _{LINE}	3.0V V _{DIFF} 40V, V _{out} = V _{ref} , T _A = 25°C 3.3V V _{DIFF} 40V, V _{out} = V _{ref} 40V V _{DIFF} 60V, V _{out} = V _{ref} , T _A = 25°C 40V V _{DIFF} 60V, V _{out} = V _{ref}	• -4.5 • -9 • -5 • -10	4.5 -9 5 10	mV
Load Regulation (Note 1)	R _{LOAD}	V _{DIFF} = 3.0V, 10mA I _L 1.5A, T _A = 25°C V _{DIFF} = 3.3V, 10mA I _L 1.5A V _{DIFF} = 40V, 10mA I _L 300mA, T _A = 25°C V _{DIFF} = 40V, 10mA I _L 195mA V _{DIFF} = 60V, 10mA I _L 30mA	• -15 • -15 • -15 • -15 • -15	15 15 15 15 15	mV
Thermal Regulation	V _{RTH}	V _{in} = 14.6V, I _L = 1.5A P _d = 20 Watts, t = 20 ms, T _A = 25°C	-5	5	mV
Ripple Rejection (Note 2)	R _N	f = 120 Hz, V _{out} = V _{ref} C _{Adj} = 10 μF, I _{out} = 100 mA	• 66		dB
Adjustment Pin Current	I _{Adj}	V _{DIFF} = 3.0V, T _A = 25°C V _{DIFF} = 3.3V V _{DIFF} = 40V V _{DIFF} = 60V	• • • •	100 100 100 100	μA
Adjustment Pin	I _{Adj}	V _{DIFF} = 3.0V, 10mA I _L 1.5A, T _A = 25°C	-5	5	
Current Change		V _{DIFF} = 3.3V, 10mA I _L 1.5A V _{DIFF} = 40V, 10mA I _L 300mA, T _A = 25°C V _{DIFF} = 40V, 10mA I _L 195mA 3.0V V _{DIFF} 40V, T _A = 25°C 3.3V V _{DIFF} 40V 3.3V V _{DIFF} 60V	• -5 • -5 • -5 • -5 • -5 • -5	5 5 5 5 5 5	μA
Minimum Load Current	I _{Lmin}	V _{DIFF} = 3.0V, V _{out} = 1.4V (forced) V _{DIFF} = 3.3V, V _{out} = 1.4V (forced) V _{DIFF} = 40V, V _{out} = 1.4V (forced) V _{DIFF} = 60V, V _{out} = 1.4V (forced)	• • • •	5.0 5.0 5.0 7.0	mA
Current Limit (Note 2)	I _{CL}	V _{DIFF} = 5V V _{DIFF} = 40V, T _A = 25°C V _{DIFF} = 60V, T _A = 25°C	• 1.5 • 0.3 • 0.05	3.5 1.5 0.50	A

ELECTRICAL CHARACTERISTICS Positive Regulator -55°C T_A 125°C, I_L = 8mA (unless otherwise specified)

Parameter	Symbol	Test Conditions	Min.	Max.	Unit
Reference Voltage	V _{REF}	V _{DIFF} = 3.0V, T _A = 25°C V _{DIFF} = 3.0V V _{DIFF} = 50V, T _A = 25°C V _{DIFF} = 50V	• -1.262 • -1.28 • -1.28 • -1.28	-1.238 -1.22 -1.22 -1.22	V
Line Regulation (Note 1)	R _{LINE}	3.0 V V _{DIFF} 50V, T _A = 25°C	• -6 • -20	6 20	mV
Load Regulation (Note 1)	R _{LOAD}	V _{DIFF} = 50V, 8mA I _L 110mA, T _A = 25°C V _{DIFF} = 5V, 8mA I _L 1.5A, T _A = 25°C	• -25 • -25 • -50	25 25 50	mV
Thermal Regulation	V _{RTH}	V _{in} = -14.6V, I _L = 1.5A P _d = 20 Watts, t = 10 ms, T _A = 25°C	-5	5	mV
Ripple Rejection (Note 2)	R _N	f = 120 Hz, V _{out} = V _{ref} C _{Adj} = 10 μF, I _{out} = 100 mA	• 66		dB
Adjustment Pin Current	I _{Adj}	V _{DIFF} = 3.0V V _{DIF} = 40V V _{DIFF} = 50V	• • •	100 100 100	μA
Adjustment Pin Current Change	I _{Adj}	V _{DIFF} = 5V, 8mA I _{out} 1.5A 3V V _{DIFF} 50V, I _L 8mA	• -5 • -6	5 6	μA
Minimum Load Current	I _{Lmin}	V _{DIFF} = 3.0V, V _{out} = -1.4V (forced) V _{DIFF} = 10V, V _{out} = -1.4V (forced) V _{DIFF} = 40V, V _{out} = -1.4V (forced) V _{DIFF} = 50V, V _{out} = -1.4V (forced)	• • • •	3.0 3.0 5.0 5.0	mA
Current Limit (Note 2)	I _{CL}	V _{DIFF} = 5V V _{DIFF} = 50V, T _A = 25°C	• 1.5 • 0.2	3.5 1.0	A

3.5

Notes for both Positive and Negative Regulators Characteristics:

1. Load and Line Regulation are specified at a constant junction temperature. Pulse testing with low duty cycle is used. Changes in output voltage due to heating effects must be taken into account separately.
2. If not tested, shall be guaranteed to the specified limits.
3. The • denotes the specifications which apply over the full operating temperature range.



POSITIVE REGULATOR - TYPICAL PERFORMANCE CHARACTERISTICS

LOAD REGULATION

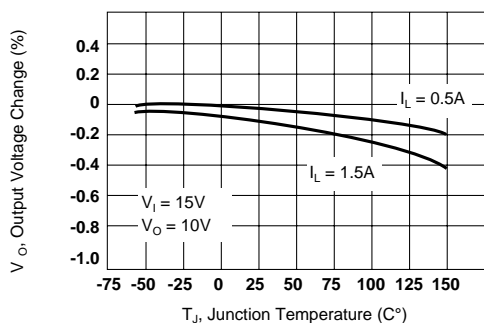

CURRENT LIMIT

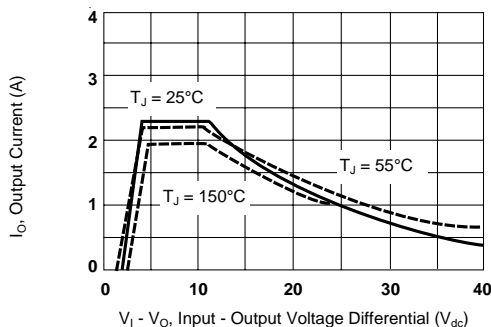

ADJUSTMENT PIN CURRENT

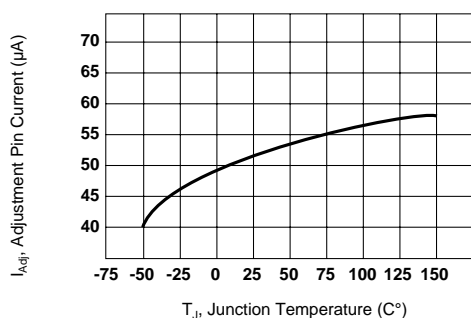

DROPOUT VOLTAGE

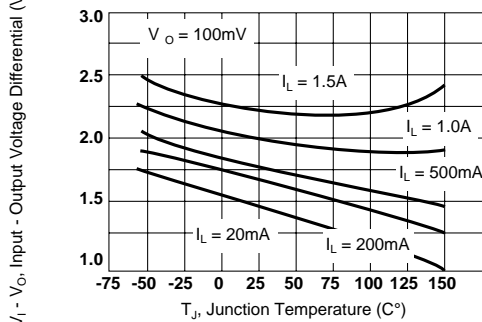

TEMPERATURE STABILITY

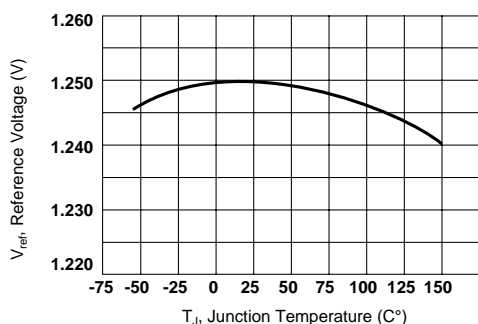

MINIMUM OPERATING CURRENT

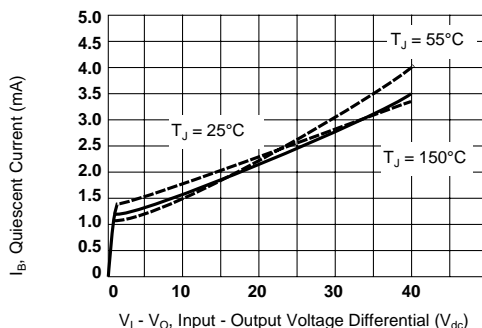

STANDARD APPLICATION

* C_{in} is required if regulator is located an appreciable distance from power supply filter.

** C_o is not needed for stability, however it does improve transient response.

$$V_{out} = 1.25 V \left(1 + \frac{R_2}{R_1} \right) + I_{Adj} R_2$$

Since I_{Adj} is controlled to less than 100 µA, the error associated with this term is negligible in most applications.

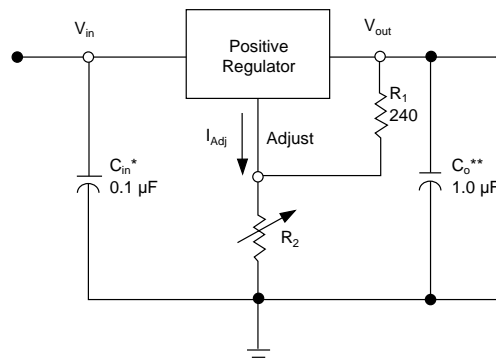

3.5

Copyright © Each Manufacturing Company.

All Datasheets cannot be modified without permission.

This datasheet has been download from :

www.AllDataSheet.com

100% Free DataSheet Search Site.

Free Download.

No Register.

Fast Search System.

www.AllDataSheet.com