

FEATURES

- Wide bandwidth: 1 MHz to 10 GHz
- Dual-channel and channel difference outputs ports
- Integrated accurately scaled temperature sensor
- 50 dB dynamic range up to 8 GHz
- Stability over temperature ± 0.5 dB
- Low noise measurement/controller output VOUT
- Pulse response time: 8/10 ns (fall/rise)
- Small footprint 5 mm x 5 mm LFCSP package
- Supply operation: 3.0 V to 5.5 V @ 65 mA
- Fabricated using high speed SiGe process

APPLICATIONS

- RF transmitter PA setpoint control and level monitoring
- Power monitoring in radiolink transmitters
- RSSI measurement in base stations, WLAN, WiMAX, radar
- Antenna VSWR monitor
- Dual-channel wireless infrastructure radios

GENERAL DESCRIPTION

The ADL5519 is a dual-demodulating logarithmic amplifier, using the AD8317 core. It has the capability of accurately converting an RF input signal to a corresponding decibel-scaled output. The ADL5519 provides accurately scaled, independent, logarithmic outputs of both RF measurement channels. Difference output ports, which measure the difference between the two channels, are also available. The on-chip channel matching makes the log-amp channel difference outputs extremely stable with temperature and process variations. The device also includes a useful temperature sensor with an accurately scaled voltage proportional to temperature, specified over the device operating temperature range.

The ADL5519 maintains accurate log conformance for signals of 1 MHz to 8 GHz and provides useful operation to 10 GHz. The input dynamic range is typically 50 dB (re: 50 Ω) with error less than ± 1 dB. The ADL5519 has 8/10 ns response time (fall time/rise time) that enables RF burst detection to a pulse rate of beyond 50 MHz. The device provides unprecedented logarithmic intercept stability vs. ambient temperature conditions. A supply of 3.0 V to 5.5 V is required to power the device. Current

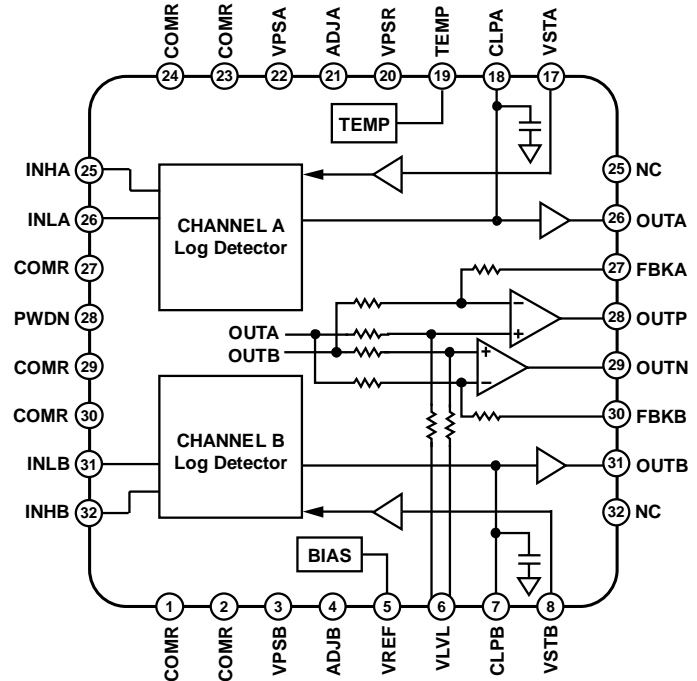

Figure 1. Functional Block Diagram

consumption is typically 65 mA, and it decreases to 1 mA when the device is disabled.

The device is capable of supplying four log-amp measurements simultaneously. Linear-in-dB measurements are provided at OUTA and OUTB, with conveniently scaled slopes of -22 mV/dB. The log-amp difference between OUTA and OUTB is available as differential or single-ended signals at OUTP and OUTN. An optional voltage applied to VLVL provides a common mode reference level to offset OUTP and OUTN above ground. On-chip wide bandwidth output op amps are connected to accommodate flexible configurations that support many system solutions.

The ADL5519 can be easily configured to provide a control voltage to a power amplifier at any output pin. Since the output can be used for controller applications, special attention has been paid to minimize wideband noise

The ADL5519 is fabricated on a SiGe bipolar IC process and is available in a 5 mm x 5 mm, 32-lead LFCSP package for an operating temperature range of -40°C to $+125^{\circ}\text{C}$.

Rev. PrB

Information furnished by Analog Devices is believed to be accurate and reliable. However, no responsibility is assumed by Analog Devices for its use, nor for any infringements of patents or other rights of third parties that may result from its use. Specifications subject to change without notice. No license is granted by implication or otherwise under any patent or patent rights of Analog Devices. Trademarks and registered trademarks are the property of their respective owners.

TABLE OF CONTENTS

Features	1	Setpoint Interface, VST[A, B]	15
Applications.....	1	Output Interface, OUT[A, B]	15
General Description	1	Difference Output, OUT[P, N]	15
Specifications.....	3	Measurement Mode	16
Absolute Maximum Ratings.....	9	Controller Mode.....	17
ESD Caution.....	9	Temperature Compensation Adjustment.....	20
Pin Configuration and Function Descriptions.....	10	Device Calibration and Error Calculation.....	20
Typical Performance Characteristics	12	Altering the Slope.....	21
Theory of Operation	13	Output Filtering.....	21
Using the ADL5519.....	14	Basis for Error Calculations.....	21
Basic Connections	14	Evaluation Board	23
Input Signal Coupling.....	14	Outline Dimensions	27
Temperature Sensor Interface.....	14	Ordering Guide	27
Power-Down Interface.....	15		

SPECIFICATIONS

V_{POS} = 5 V, C_{LPF} = 1000 pF, T_A = 25°C, 52.3 Ω termination resistor at INHI, unless otherwise noted.

Table 1.

Parameter	Conditions	Min	Typ	Max	Unit
SIGNAL INPUT INTERFACE	INH[A, B] (Pins 19, 24)				
Specified Frequency Range		0.001		10	GHz
DC Common-Mode Voltage			V _{POS} - 0.6		V
MEASUREMENT MODE	OUT[A, B] (Pins 12, 7) shorted to VST[A,B] (Pin 13, 6), OUT[P, N] (Pins 10, 9) shorted to FBK[A, B] [Pins 11, 8] respectively, sinusoidal input signal, error referred to best fit line using linear regression @ P _{INH[A, B]} = -40 dBm and -20 dBm, T _A = +25°C				
f = 100 MHz	ADJA = ADJB = TBD to GND				
Input Impedance			TBD		Ω pF
OUT[A, B] ±1 dB Dynamic Range	T _A = +25°C		50		dB
	-40°C < T _A < +85°C		46		dB
	-40°C < T _A < +125°C		TBD		dB
OUT[A, B] Maximum Input Level	±1 dB error		-3		dBm
OUT[A, B] Minimum Input Level	±1 dB error		-53		dBm
OUT[A, B, P, N] Slope		TBD	-22	TBD	mV/dB
OUT[A, B] Intercept		TBD	15	TBD	dBm
Output Voltage - High Power In	Pins OUT[A, B] @ P _{INH[A, B]} = -10 dBm	TBD	0.58	TBD	V
Output Voltage - Low Power In	Pins OUT[A, B] @ P _{INH[A, B]} = -40 dBm	TBD	1.27	TBD	V
Temperature Sensitivity	Deviation from OUT[A, B] @ 25°C				
	-40°C < T _A < 85°C; P _{INH[A, B]} = -10 dBm		TBD		dB
	-40°C < T _A < 85°C; P _{INH[A, B]} = -25 dBm		TBD		dB
	-40°C < T _A < 85°C; P _{INH[A, B]} = -40 dBm		TBD		dB
OUTP-OUTN Dynamic Gain Range	±1 dB error		TBD		dB
	-40°C < T _A < 85°C		TBD		dB
Temperature Sensitivity	OUTP-OUTN Dynamic Gain Range		TBD		
	-40°C < T _A < 85°C; P _{INH[A, B]} = -10 dBm, -25 dBm		TBD		dB
	-40°C < T _A < 85°C; P _{INH[A, B]} = -25 dBm, -25 dBm		TBD		dB
	-40°C < T _A < 85°C; P _{INH[A, B]} = -40 dBm, -25 dBm		TBD		dB
Input A to Input B Isolation			TBD		dB
Input A to OUTB Isolation	Freq separation = 1 kHz		TBD		
Input B to OUTA Isolation	P _{INHB} = -50 dBm, OUTB = OUTB _{P_{INHB}} ± 1 dB		TBD		dB
	P _{INHA} = -50 dBm, OUTA = OUTA _{P_{INHA}} ± 1 dB		TBD		dB
f = 900 MHz	ADJA = ADJB = TBD to GND				
Input Impedance			TBD		Ω pF
OUT[A, B] ±1 dB Dynamic Range	T _A = +25°C		50		dB
	-40°C < T _A < +85°C		46		dB
	-40°C < T _A < +125°C		TBD		
OUT[A, B] Maximum Input Level	±1 dB error		-3		dBm
OUT[A, B] Minimum Input Level	±1 dB error		-53		dBm
OUT[A, B, P, N] Slope		TBD	-22	TBD	mV/dB
OUT[A, B] Intercept		TBD	15	TBD	dBm
Output Voltage - High Power In	Pins OUT[A, B] @ P _{INH[A, B]} = -10 dBm	TBD	0.58	TBD	V
Output Voltage - Low Power In	Pins OUT[A, B] @ P _{INH[A, B]} = -40 dBm	TBD	1.27	TBD	V

Parameter	Conditions	Min	Typ	Max	Unit
Temperature Sensitivity	Deviation from OUT[A, B] @ 25°C 25°C < T _A < 85°C; P _{INH[A, B]} = -10 to -15 dBm -20°C < T _A < 25°C; P _{INH[A, B]} = -10 to -15 dBm 25°C < T _A < 85°C; P _{INH[A, B]} = -10 to -40 dBm -20°C < T _A < 25°C; P _{INH[A, B]} = -10 to -40 dBm	±.25	TBD		dB
OUTP-OUTN Dynamic Gain Range	±1 dB error -40°C < T _A < 85°C		TBD		dB
Temperature Sensitivity	OUTP-OUTN Dynamic Gain Range 25°C < T _A < 85°C; P _{INH[A, B]} = -10 to -15 dBm -20°C < T _A < 25°C; P _{INH[A, B]} = -10 to -15 dBm 25°C < T _A < 85°C; P _{INH[A, B]} = -10 to -40 dBm -20°C < T _A < 25°C; P _{INH[A, B]} = -10 to -40 dBm	±.25	TBD		dB
Input A to Input B Isolation			TBD		dB
Input A to OUTB Isolation	Freq separation = 1 kHz		TBD		dB
Input B to OUTA Isolation	P _{INH[B]} = -50 dBm, OUTB = OUTB _{PINH[B]} ± 1 dB P _{INH[A]} = -50 dBm, OUTA = OUTA _{PINH[A]} ± 1 dB		TBD		dB
f = 1.9 GHz	ADJA = ADJB = TBD to GND				
Input Impedance			950 0.38		Ω pF
OUT[A, B] ±1 dB Dynamic Range	T _A = +25°C -40°C < T _A < +85°C -40°C < T _A < +125°C		50 48 TBD		dB dB
OUT[A, B] Maximum Input Level	±1 dB error		-4		dBm
OUT[A, B] Minimum Input Level	±1 dB error		-54		dBm
OUT[A, B, P, N] Slope		TBD	-22	TBD	mV/dB
OUT[A, B] Intercept		TBD	14	TBD	dBm
Output Voltage - High Power In	Pins OUT[A, B] @ P _{INH[A, B]} = -10 dBm	TBD	0.54	TBD	V
Output Voltage - Low Power In	Pins OUT[A, B] @ P _{INH[A, B]} = -40 dBm	TBD	1.21	TBD	V
Temperature Sensitivity	Deviation from OUT[A, B] @ 25°C 25°C < T _A < 85°C; P _{INH[A, B]} = -10 to -15 dBm -20°C < T _A < 25°C; P _{INH[A, B]} = -10 to -15 dBm 25°C < T _A < 85°C; P _{INH[A, B]} = -10 to -40 dBm -20°C < T _A < 25°C; P _{INH[A, B]} = -10 to -40 dBm	±.25	TBD		dB
OUTP-OUTN Dynamic Gain Range	±1 dB error -40°C < T _A < 85°C		TBD		dB
Temperature Sensitivity	OUTP-OUTN Dynamic Gain Range 25°C < T _A < 85°C; P _{INH[A, B]} = -10 to -15 dBm -20°C < T _A < 25°C; P _{INH[A, B]} = -10 to -15 dBm 25°C < T _A < 85°C; P _{INH[A, B]} = -10 to -40 dBm -20°C < T _A < 25°C; P _{INH[A, B]} = -10 to -40 dBm	±.25	TBD		dB
Input A to Input B Isolation			TBD		dB
Input A to OUTB Isolation	Freq separation = 1 kHz		TBD		dB
Input B to OUTA Isolation	P _{INH[B]} = -50 dBm, OUTB = OUTB _{PINH[B]} ± 1 dB P _{INH[A]} = -50 dBm, OUTA = OUTA _{PINH[A]} ± 1 dB		TBD		dB
f = 2.2 GHz	ADJA = ADJB = TBD to GND				
Input Impedance			TBD		Ω pF
OUT[A, B] ±1 dB Dynamic Range	T _A = +25°C -40°C < T _A < +85°C -40°C < T _A < +125°C		50 47 TBD		dB dB

Parameter	Conditions	Min	Typ	Max	Unit
OUT[A, B] Maximum Input Level	±1 dB error		-5		dBm
OUT[A, B] Minimum Input Level	±1 dB error		-55		dBm
OUT[A, B, P, N] Slope			-22		mV/dB
OUT[A, B] Intercept			14		dBm
Output Voltage - High Power In	Pins OUT[A, B] @ P _{INH[A, B]} = -10 dBm		0.53		V
Output Voltage - Low Power In	Pins OUT[A, B] @ P _{INH[A, B]} = -40 dBm		1.20		V
Temperature Sensitivity	Deviation from OUT[A, B] @ 25°C				
	25°C < T _A < 85°C; P _{INH[A, B]} = -10 to -15 dBm	±.25	TBD		dB
	-20°C < T _A < 25°C; P _{INH[A, B]} = -10 to -15 dBm	±.25	TBD		dB
	25°C < T _A < 85°C; P _{INH[A, B]} = -10 to -40 dBm	±.25	TBD		dB
	-20°C < T _A < 25°C; P _{INH[A, B]} = -10 to -40 dBm	±.5	TBD		dB
OUTP-OUTN Dynamic Gain Range	±1 dB error		TBD		dB
	-40°C < T _A < 85°C		TBD		dB
Temperature Sensitivity	OUTP-OUTN Dynamic Gain Range		TBD		
	25°C < T _A < 85°C; P _{INH[A, B]} = -10 to -15 dBm	±.25	TBD		dB
	-20°C < T _A < 25°C; P _{INH[A, B]} = -10 to -15 dBm	±.25	TBD		dB
	25°C < T _A < 85°C; P _{INH[A, B]} = -10 to -40 dBm	±.25	TBD		dB
	-20°C < T _A < 25°C; P _{INH[A, B]} = -10 to -40 dBm	±.5	TBD		dB
Input A to Input B Isolation			TBD		dB
Input A to OUTB Isolation	Freq separation = 1 kHz		TBD		
Input B to OUTA Isolation ¹	P _{INH[B]} = -50 dBm, OUTB = OUTB _{PINH[B]} ± 1 dB P _{INH[A]} = -50 dBm, OUTA = OUTA _{PINH[A]} ± 1 dB		TBD		dB
			TBD		dB
f = 3.6 GHz	ADJA = ADJB = TBD to GND				
Input Impedance			TBD		Ω pF
OUT[A, B] ±1 dB Dynamic Range	T _A = +25°C		42		dB
	-40°C < T _A < +85°C		40		dB
	-40°C < T _A < +125°C		TBD		
OUT[A, B] Maximum Input Level	±1 dB error		-6		dBm
OUT[A, B] Minimum Input Level	±1 dB error		-48		dBm
OUT[A, B, P, N] Slope			-22		mV/dB
OUT[A, B] Intercept			11		dBm
Output Voltage - High Power In	Pins OUT[A, B] @ P _{INH[A, B]} = -10 dBm		0.47		V
Output Voltage - Low Power In	Pins OUT[A, B] @ P _{INH[A, B]} = -40 dBm		1.16		V
Temperature Sensitivity	Deviation from OUT[A, B] @ 25°C				
	-40°C < T _A < 85°C; P _{INH[A, B]} = -10 dBm		TBD		dB
	-40°C < T _A < 85°C; P _{INH[A, B]} = -25 dBm		TBD		dB
	-40°C < T _A < 85°C; P _{INH[A, B]} = -40 dBm		TBD		dB
OUTP-OUTN Dynamic Gain Range	±1 dB error		TBD		dB
	-40°C < T _A < 85°C		TBD		dB
Temperature Sensitivity	OUTP-OUTN Dynamic Gain Range		TBD		
	-40°C < T _A < 85°C; P _{INH[A, B]} = -10 dBm, -25 dBm		TBD		dB
	-40°C < T _A < 85°C; P _{INH[A, B]} = -25 dBm, -25 dBm		TBD		dB
	-40°C < T _A < 85°C; P _{INH[A, B]} = -40 dBm, -25 dBm		TBD		dB
Input A to Input B Isolation			TBD		dB
Input A to OUTB Isolation	Freq separation = 1 kHz		TBD		
Input B to OUTA Isolation ²	P _{INH[B]} = -50 dBm, OUTB = OUTB _{PINH[B]} ± 1 dB P _{INH[A]} = -50 dBm, OUTA = OUTA _{PINH[A]} ± 1 dB		TBD		dB
			TBD		dB

Parameter	Conditions	Min	Typ	Max	Unit
f = 5.8 GHz	ADJA = ADJB = TBD to GND				
Input Impedance			TBD		Ω pF
OUT[A, B] ± 1 dB Dynamic Range	$T_A = +25^\circ\text{C}$		50		dB
	$-40^\circ\text{C} < T_A < +85^\circ\text{C}$		48		dB
	$-40^\circ\text{C} < T_A < +125^\circ\text{C}$		TBD		
OUT[A, B] Maximum Input Level	± 1 dB error		-4		dBm
OUT[A, B] Minimum Input Level	± 1 dB error		-54		dBm
OUT[A, B, P, N] Slope			-22		mV/dB
OUT[A, B] Intercept			16		dBm
Output Voltage - High Power In	Pins OUT[A, B] @ $P_{\text{INH}[A, B]} = -10$ dBm		0.59		V
Output Voltage - Low Power In	Pins OUT[A, B] @ $P_{\text{INH}[A, B]} = -40$ dBm		1.27		V
Temperature Sensitivity	Deviation from OUT[A, B] @ 25°C				
	$-40^\circ\text{C} < T_A < 85^\circ\text{C}; P_{\text{INH}[A, B]} = -10$ dBm		TBD		dB
	$-40^\circ\text{C} < T_A < 85^\circ\text{C}; P_{\text{INH}[A, B]} = -25$ dBm		TBD		dB
	$-40^\circ\text{C} < T_A < 85^\circ\text{C}; P_{\text{INH}[A, B]} = -40$ dBm		TBD		dB
OUTP-OUTN Dynamic Gain Range	± 1 dB error		TBD		dB
	$-40^\circ\text{C} < T_A < 85^\circ\text{C}$		TBD		dB
Temperature Sensitivity	OUTP-OUTN Dynamic Gain Range		TBD		
	$-40^\circ\text{C} < T_A < 85^\circ\text{C}; P_{\text{INH}[A, B]} = -10$ dBm, -25 dBm		TBD		dB
	$-40^\circ\text{C} < T_A < 85^\circ\text{C}; P_{\text{INH}[A, B]} = -25$ dBm, -25 dBm		TBD		dB
	$-40^\circ\text{C} < T_A < 85^\circ\text{C}; P_{\text{INH}[A, B]} = -40$ dBm, -25 dBm		TBD		dB
Input A to Input B Isolation			TBD		dB
Input A to OUTB Isolation	Freq separation = 1 kHz		TBD		
Input B to OUTA Isolation ³	$P_{\text{INHB}} = -50$ dBm, $\text{OUTB} = \text{OUTB}_{\text{PINHB}} \pm 1$ dB		TBD		dB
	$P_{\text{INHA}} = -50$ dBm, $\text{OUTA} = \text{OUTA}_{\text{PINHA}} \pm 1$ dB		TBD		dB
f = 8 GHz	ADJA = ADJB = TBD to GND				
Input Impedance			TBD		Ω pF
OUT[A, B] ± 1 dB Dynamic Range	$T_A = +25^\circ\text{C}$		44		dB
	$-40^\circ\text{C} < T_A < +85^\circ\text{C}$				dB
	$-40^\circ\text{C} < T_A < +125^\circ\text{C}$				
OUT[A, B] Maximum Input Level	± 1 dB error		-2		dBm
OUT[A, B] Minimum Input Level	± 1 dB error		-46		dBm
OUT[A, B, P, N] Slope			-22		mV/dB
OUT[A, B] Intercept			21		dBm
Output Voltage - High Power In	Pins OUT[A, B] @ $P_{\text{INH}[A, B]} = -10$ dBm		0.7		V
Output Voltage - Low Power In	Pins OUT[A, B] @ $P_{\text{INH}[A, B]} = -40$ dBm		1.39		V
Temperature Sensitivity	Deviation from OUT[A, B] @ 25°C				
	$-40^\circ\text{C} < T_A < 85^\circ\text{C}; P_{\text{INH}[A, B]} = -10$ dBm		TBD		dB
	$-40^\circ\text{C} < T_A < 85^\circ\text{C}; P_{\text{INH}[A, B]} = -25$ dBm		TBD		dB
	$-40^\circ\text{C} < T_A < 85^\circ\text{C}; P_{\text{INH}[A, B]} = -40$ dBm		TBD		dB
OUTP-OUTN Dynamic Gain Range	± 1 dB error		TBD		dB
	$-40^\circ\text{C} < T_A < 85^\circ\text{C}$		TBD		dB
Temperature Sensitivity	OUTP-OUTN Dynamic Gain Range		TBD		
	$-40^\circ\text{C} < T_A < 85^\circ\text{C}; P_{\text{INH}[A, B]} = -10$ dBm, -25 dBm		TBD		dB
	$-40^\circ\text{C} < T_A < 85^\circ\text{C}; P_{\text{INH}[A, B]} = -25$ dBm, -25 dBm		TBD		dB
	$-40^\circ\text{C} < T_A < 85^\circ\text{C}; P_{\text{INH}[A, B]} = -40$ dBm, -25 dBm		TBD		dB
Input A to Input B Isolation			TBD		dB
Input A to OUTB Isolation	Freq separation = 1 kHz		TBD		

Parameter	Conditions	Min	Typ	Max	Unit
Input B to OUTA Isolation	$P_{INH B} = -50 \text{ dBm}$, $OUT_B = OUT_{B_{PINHB}} \pm 1 \text{ dB}$		TBD		dB
	$P_{INH A} = -50 \text{ dBm}$, $OUT_A = OUT_{A_{PINHA}} \pm 1 \text{ dB}$		TBD		dB
OUTPUT INTERFACE	OUT[A, B] (Pins 12, 7), OUT[P, N] (Pins 10, 9)				
OUT[A, B] Voltage Range Min	VST[A, B] = TBD RFIN = open $RL \geq 240\Omega$ to ground		TBD		V
	VST[A, B] = 0V RFIN = open $RL \geq 240\Omega$ to ground		TBD		V
OUT[P, N] output	OUT[A, B] = OUT[P, N]		VLVL		
OUT[P, N] Voltage Range Min	FBK[A, B] = TBD RFIN = open $RL \geq 240\Omega$ to ground		TBD		V
	FBK[A, B] = 0V RFIN = open $RL \geq 240\Omega$ to ground		TBD		V
Source/Sink Current	Output held at 1V to 1% change		2.2		mA
Small Signal Bandwidth	RFIN = -10 dBm, from CLP[A,B] to OUT[A,B]		TBD		MHz
Output Noise	RF Input = 2.2 GHz, -10 dBm, $f_{NOISE} = 100 \text{ kHz}$, $C_{LP[A,B]} = \text{open}$		TBD		nV/ $\sqrt{\text{Hz}}$
Fall Time	Input level = no signal to -10 dBm, 90% to 10%, $C_{LP[A,B]} = 8 \text{ pF}$		TBD		ns
Fall Time	Input level = no signal to -10 dBm, 90% to 10%, $C_{LP[A,B]} = \text{open}$;		TBD		ns
Rise Time	Input level = -10 dBm to no signal, 10% to 90%, $C_{LP[A,B]} = 8 \text{ pF}$		TBD		ns
Rise Time	Input level = -10 dBm to no signal, 10% to 90%, $C_{LP[A,B]} = \text{open}$,		TBD		ns
Video Bandwidth (or Envelope Bandwidth)			50		MHz
SETPOINT INTERFACE	VST[A, B] (Pins 13, 6)				
Nominal Input Range	Input level = 0 dBm, measurement mode		0.5		V
	Input level = -50 dBm, measurement mode		1.75		V
Logarithmic Scale Factor			-45		dB/V
Logarithmic Intercept			TBD		
Input Resistance	Input level = -20 dBm, controller mode, VST[A,B] = 1 V		40		k Ω
DIFFERENCE LEVEL ADJUST	VLVL (Pin 4)				
Voltage Range	OUT[P, N] = FBK[A, B]		TBD		V
OUT[P, N] Voltage Range	OUT[P, N] = FBK[A, B]		TBD		V
Input Impedance			TBD		ΩpF
TEMPERATURE COMPENSATION	ADJ[A, B] (Pins 17, 2)				
Input Resistance	ADJ[A, B] = 0.9 V, sourcing 50 μA		13		k Ω
Disable Threshold Voltage	ADJ[A, B] = open		$V_{POS} - 0.4$		V
VOLTAGE REFERENCE	VREF (Pin 3)				
Output Voltage			1.15		V
Temperature Sensitivity	$-40^\circ\text{C} < T_A < +85^\circ\text{C}$		TBD		mV/ $^\circ\text{C}$
Current Limit Source/Sink			3/3		mA
TEMPERATURE REFERENCE	TEMP (Pin 15)				
Output Voltage			1.3		V
Temperature Sensitivity	$-40^\circ\text{C} < T_A < +125^\circ\text{C}$		4.5		mV/ $^\circ\text{C}$
Current Limit Source/Sink			5/40		mA/ μA
POWER-DOWN INTERFACE	Pin PWDN				
Logic Level to Enable	Logic LO enables		TBD		V
Logic Level to Disable	Logic HI disables		TBD		V
Input Current	Logic HI PWDN = 5 V		TBD		μA
	Logic LO PWDN = 0 V		TBD		μA
Enable Time	PWDN LO to OUTA/OUTB at 100% final value, $C_{HPA/B} = \text{Open}$, $C_{HPA/B} = 10 \text{ nF}$, RF in = 0 dBm		TBD		μs

Parameter	Conditions	Min	Typ	Max	Unit
Disable Time	PWDN HI to OUTA/OUTB at 10% final value, $C_{LPA/B} = \text{Open}$, $C_{HPA/B} = 10\text{nF}$, RF in = 0 dBm		TBD		μs
POWER INTERFACE	VPS[A, B, R] (Pins 18, 1, 16)				
Supply Voltage		3.0		5.5	V
Quiescent Current			65		mA
vs. Temperature	$-40^{\circ}\text{C} \leq T_A \leq +125^{\circ}\text{C}$		TBD		$\mu\text{A}/^{\circ}\text{C}$
Disable Current	ADJ[A,B] = PWDN = VPOS		1		mA

ABSOLUTE MAXIMUM RATINGS

Table 2.

Parameter	Rating
Supply Voltage: VPSA, VPSB, VPSR	5.7 V
V _{SET} Voltage: VSTA, VSTB	0 to V _{POS}
Input Power (Single-Ended, Re: 50 Ω) INHA, INLA, INHB, INLB	12 dBm
Internal Power Dissipation θ _{JA}	55°C/W
Maximum Junction Temperature	165°C
Operating Temperature Range	-40°C to +125°C
Storage Temperature Range	-65°C to +150°C
Lead Temperature (Soldering 60 sec)	260°C

Stresses above those listed under Absolute Maximum Ratings may cause permanent damage to the device. This is a stress rating only; functional operation of the device at these or any other conditions above those indicated in the operational section of this specification is not implied. Exposure to absolute maximum rating conditions for extended periods may affect device reliability.

ESD CAUTION

ESD (electrostatic discharge) sensitive device. Electrostatic charges as high as 4000 V readily accumulate on the human body and test equipment and can discharge without detection. Although this product features proprietary ESD protection circuitry, permanent damage may occur on devices subjected to high energy electrostatic discharges. Therefore, proper ESD precautions are recommended to avoid performance degradation or loss of functionality.



PIN CONFIGURATION AND FUNCTION DESCRIPTIONS

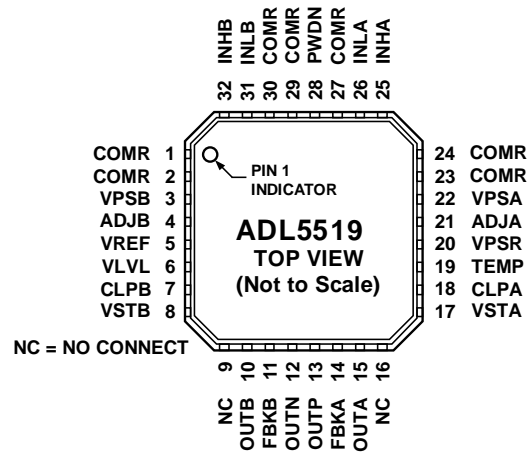

Figure 2. Pin Configuration

Table 3. Pin Function Descriptions

PIN	Name	Description
1	COMR	Common for difference output and Temp Sensor
2	COMR	Common for difference output and Temp Sensor
3	VPSB	Positive Supply for Channel B. Must be the same as VPS[A/R]. Apply 3.0V to 5.5V supply voltage.
4	ADJB	Dual function pin. Channel B Temperature adjust. Connect a resistor to ground to vary temperature compensation. Connect to VPS[A/B/R] to power down Channel B.
5	VREF	1.15V voltage reference
6	VLVL	DC common mode adjust for difference output
7	CLPB	Loop filter pin for Channel B
8	VSTB	Setpoint Control input for Channel B
9	NC	No Connect
10	OUTB	Output voltage for Channel B
11	FBKB	Difference op-amp feedback pin
12	OUTN	Difference output (OUTB - OUTA + VLVL)
13	OUTP	Difference output (OUTA - OUTB + VLVL)
14	FBKA	Difference op-amp feedback pin
15	OUTA	Output voltage for Channel A
16	NC	No Connect
17	VSTA	Setpoint Control input for Channel A
18	CLPA	Loop filter pin for Channel A
19	TEMP	Temp Sensor output (1.3V with 4.5mV/°C slope)
20	VPSR	Positive Supply for difference output and temperature sensor. Must be the same as VPS[A/B]. Apply 3.0V to 5.5V supply voltage.
21	ADJA	Dual function pin. Channel A Temperature adjust. Connect a resistor to ground to vary temperature compensation. Connect to VPS[A/B/R] to power down Channel A.
22	VPSA	Positive Supply for Channel A. Must be the same as VPS[B/R]. Apply 3.0V to 5.5V supply voltage.
23	COMR	Common for difference output and Temp Sensor
24	COMR	Common for difference output and Temp Sensor
25	INHA	AC coupled RF input for Channel A
26	INLA	AC coupled RF common for Channel A
27	COMR	Common for difference output and Temp Sensor
28	PWDN	Power down for difference output and Temp Sensor

29	COMR	Common for difference output and Temp Sensor
30	COMR	Common for difference output and Temp Sensor
31	INLB	AC coupled RF common for Channel B
32	INHB	AC coupled RF input for Channel B
	Paddle	Internally connected to COMR

TYPICAL PERFORMANCE CHARACTERISTICS

$V_P = 5\text{ V}$; $T_A = +25^\circ\text{C}$, -40°C , $+85^\circ\text{C}$; CLPA/B = OPEN. Colors: $+25^\circ\text{C}$ black, -40°C blue, $+85^\circ\text{C}$ red.

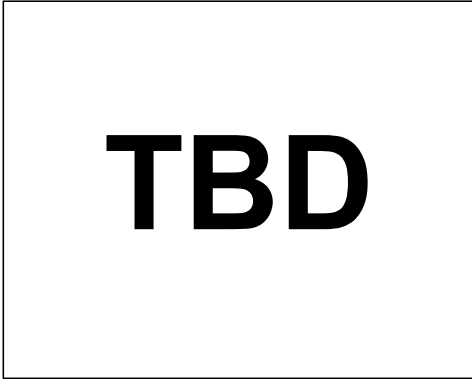

Figure 3: $OUT[A, B]$ Voltage and Log Conformance vs. Input Amplitude at 450 MHz, Typical Device, $ADJ[A, B] = 0\text{ V}$, Sine Wave, Differential Drive,

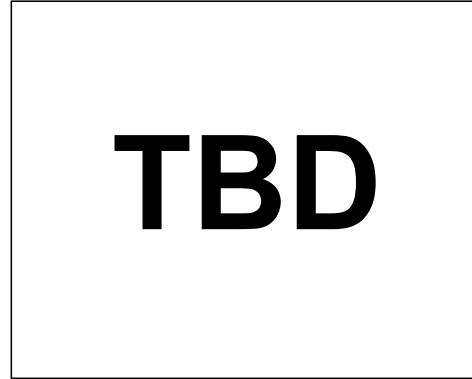

Figure 6: $OUT[P, N]$ Gain and Log Conformance vs. Input Amplitude at 450 MHz, Typical Device, $ADJ[A, B] = 0\text{ V}$, Sine Wave, Differential Drive (Note that the $OUTP$ and $OUTN$ Error Curves Overlap)

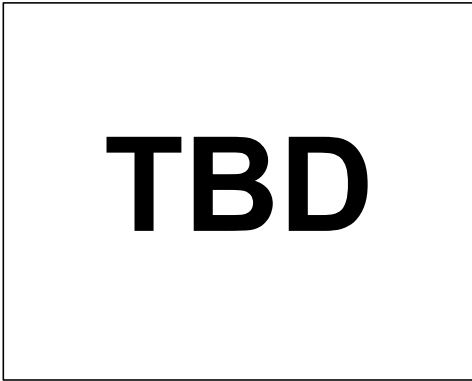

Figure 4: Distribution of $OUT[A, B]$ Voltage and Error over Temperature After Ambient Normalization vs. Input Amplitude for at Least 30 Devices from Multiple Lots, Frequency = 450 MHz, $ADJ[A, B] = 0\text{ V}$, Sine Wave, Differential Drive

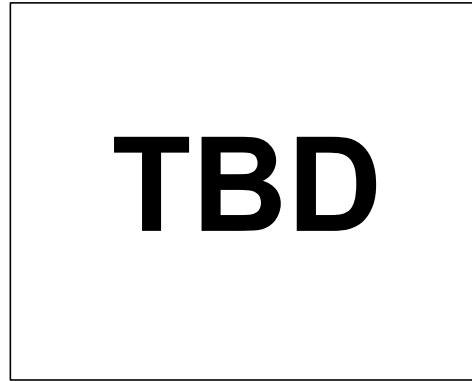

Figure 7: Distribution of $[OUTP - OUTN]$ Gain and Error over Temperature After Ambient Normalization vs. Input Amplitude for at Least 30 Devices from Multiple Lots, Frequency = 450 MHz, $ADJ[A, B] = 0\text{ V}$, Sine Wave, Differential Drive, P_{IN} Ch. B = -25 dBm , Channel A Swept

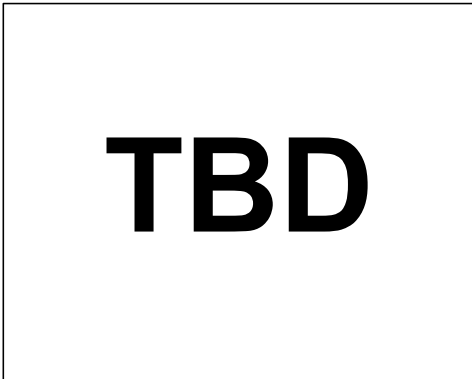

Figure 5: Distribution of $[OUTA - OUTB]$ Gain vs. Input Amplitude over Temperature for at Least 30 Devices from Multiple Lots, Frequency = 450 MHz, $ADJ[A, B] = 0\text{ V}$, Sine Wave, Differential Drive

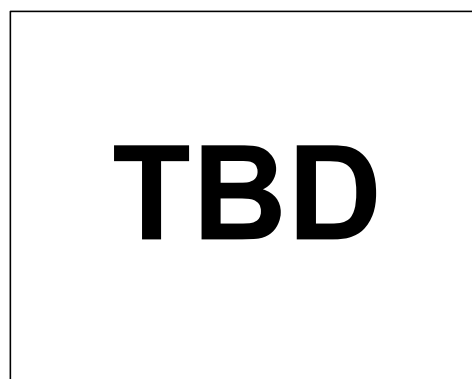

Figure 8: $OUT[A, B]$ Voltage and Log Conformance vs. Input Amplitude at 880 MHz, Typical Device, $ADJ[A, B] = 0.5\text{ V}$, Sine Wave, Differential Drive,

THEORY OF OPERATION

The ADL5519 is a dual-channel 6-stage demodulating logarithmic amplifier, specifically designed for use in RF measurement and power control applications at frequencies up to 10 GHz. Sharing much of its design with the AD8317 logarithmic detector/controller, the ADL5519 maintains tight intercept variability vs. temperature over a 50 dB range. Each measurement channel offers equivalent performance to the AD8317. The complete circuit block diagram is shown in Figure 9.

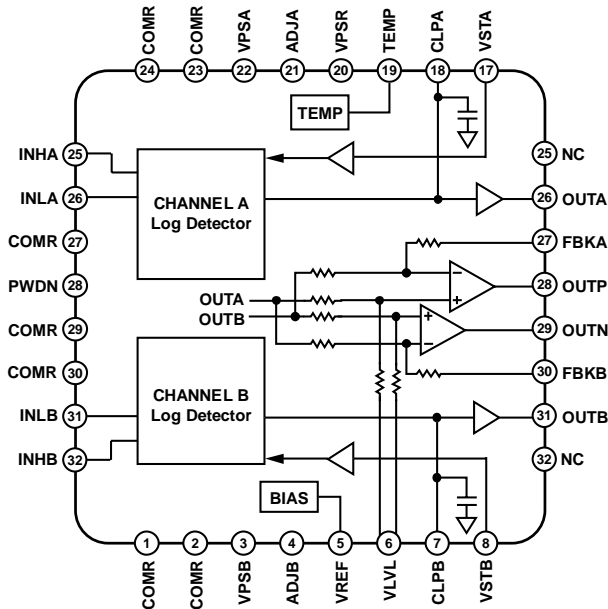

Figure 9. Block Diagram

Each measurement channel is a fully differential design and uses a proprietary, high speed SiGe process, extending high frequency performance. Figure 10 shows the basic diagram of the ADL5519's channel A signal path, the functionality is identical for channel B.

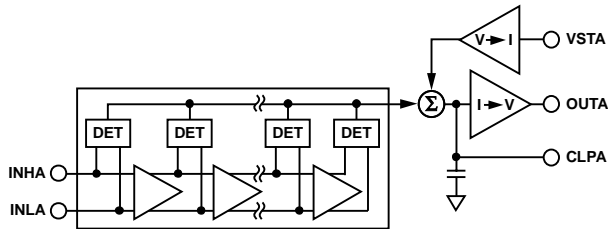

Figure 10. Single Channel Block Diagram

The maximum input with ±1 dB log-conformance error is typically 0 dBm (re: 50 Ω). The noise spectral density referred to the input is 1.15 nV/√Hz, which is equivalent to a voltage of 118 μV rms in a 10.5 GHz bandwidth or a noise power of -66 dBm (re: 50 Ω). This noise spectral density sets the lower limit of the dynamic range. However, the low end accuracy of the ADL5519 is enhanced by specially shaping the demodulating transfer characteristic to partially compensate for errors due to internal noise. The common pin, COMR, provides a quality low impedance connection to the printed circuit board (PCB) ground. The package paddle, which is internally connected to the COMR pin, should also be grounded to the PCB to reduce thermal impedance from the die to the PCB.

The logarithmic function is approximated in a piecewise fashion by six cascaded gain stages. (For a more comprehensive explanation of the logarithm approximation, please refer to the AD8307 data sheet, available at www.analog.com.) The cells have a nominal voltage gain of 9 dB each and a 3 dB bandwidth of 10.5 GHz. Using precision biasing, the gain is stabilized over temperature and supply variations. The overall dc gain is high, due to the cascaded nature of the gain stages. An offset compensation loop is included to correct for offsets within the cascaded cells. At the output of each of the gain stages, a square-law detector cell is used to rectify the signal.

The RF signal voltages are converted to a fluctuating differential current having an average value that increases with signal level. Along with the six gain stages and detector cells, an additional detector is included at the input of each measurement channel, providing a 50 dB dynamic range in total. After the detector currents are summed and filtered, the following function is formed at the summing node:

$$I_D \times \log_{10}(V_{IN}/V_{INTERCEPT})$$

where:

I_D is the internally set detector current.

V_{IN} is the input signal voltage.

$V_{INTERCEPT}$ is the intercept voltage (that is, when $V_{IN} = V_{INTERCEPT}$, the output voltage would be 0 V, if it were capable of going to 0 V).

USING THE ADL5519

BASIC CONNECTIONS

The ADL5519 is specified for operation up to 10 GHz; as a result, low impedance supply pins with adequate isolation between functions are essential. A power supply voltage of between 3.0 V and 5.5 V should be applied to VPSA, VPSB, and VPSR. Power supply decoupling capacitors of 100 pF and 0.1 μ F should be connected close to these power supply pins.

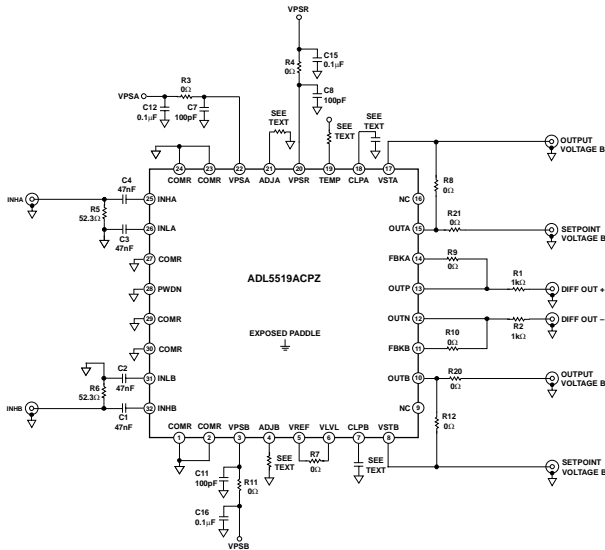

Figure 11. Basic Connections

The paddle of the LFCSP_VD package is internally connected to COMR. For optimum thermal and electrical performance, the paddle should be soldered to a low impedance ground plane.

INPUT SIGNAL COUPLING

The RF inputs (INHA and INHB) are single-ended and must be ac-coupled. INLA and INLB (input common) should be ac-coupled to ground. Suggested coupling capacitors are 47 nF ceramic 0402-style capacitors for input frequencies of 1 MHz to 10 GHz. The coupling capacitors should be mounted close to the INHA[INHB] and INLA[INLB] pins. The coupling capacitor values can be increased to lower the input stage's high-pass cutoff frequency. The high-pass corner is set by the input coupling capacitors and the internal 10 pF high-pass capacitor. The dc voltage on INHA[INHB] and INLA[INLB] is about one diode voltage drop below the supply voltage.

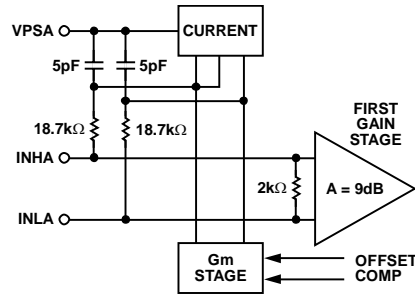

Figure 12. Single Channel Input Interface

While the input can be reactively matched, in general this is not necessary. An external 52.3 Ω shunt resistor (connected on the signal side of the input coupling capacitors, as shown in Figure 11) combines with the relatively high input impedance to give an adequate broadband 50 Ω match.

The coupling time constant, $50 \times C_c/2$, forms a high-pass corner with a 3 dB attenuation at $f_{HP} = 1/(2\pi \times 50 \times C_c)$, where $C_1 = C_2 = C_c$. Using the typical value of 47 nF, this high pass corner will be ~ 68 kHz. In high frequency applications, f_{HP} should be as large as possible to minimize the coupling of unwanted low frequency signals. In low frequency applications, a simple RC network forming a low-pass filter should be added at the input for similar reasons. This should generally be placed at the generator side of the coupling capacitors, thereby lowering the required capacitance value for a given high-pass corner frequency.

TEMPERATURE SENSOR INTERFACE

The ADL5519 provides a temperature sensor output capable of driving about 1.6 mA. The temperature scaling factor of the output voltage is approximately 2 mV/ $^{\circ}$ C. The typical absolute voltage at 25 $^{\circ}$ C is ~ 620 mV.

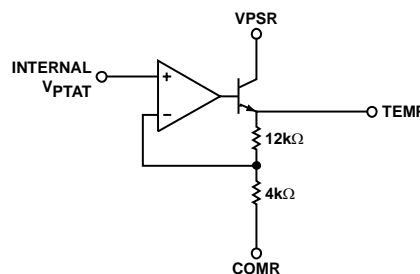

Figure 13. TEMP Interface Simplified Schematic

POWER-DOWN INTERFACE

The operating and stand-by currents for the ADL5519 at 25°C are approximately 65 mA and 1 mA, respectively. The PWDN and ADJ[A,B] pins are connected to the base of and NPN transistor to force a power down condition. Typically, when PWDN is pulled >2.5 V, the ADL5519 is powered down from 65mA to <1mA. The output reaches to within 0.1 dB of its steady-state value in about 1.6 μs; the reference voltage is available to full accuracy in a much shorter time. This wake-up response time varies depending on the input coupling network and the capacitance at pins CLP[A, B].

The individual log channels can be disabled by installing a 0Ω pull up resistor from ADJ[A,B] to VPS[A,B].

SETPOINT INTERFACE, VST[A, B]

The V_{SET} input drives the high impedance (20 kΩ) input of an internal op amp. The V_{SET} voltage appears across the internal 1.5 kΩ resistor to generate I_{SET}. When a portion of V_{OUT} is applied to VSET, the feedback loop forces

$$-I_D \times \log_{10}(V_{IN}/V_{INTERCEPT}) = I_{SET}$$

If $V_{SET} = V_{OUT}/2x$, then $I_{SET} = V_{OUT}/(2x \times 1.5 \text{ k}\Omega)$.

The result is

$$V_{OUT} = (-I_D \times 1.5 \text{ k}\Omega \times 2x) \times \log_{10}(V_{IN}/V_{INTERCEPT})$$

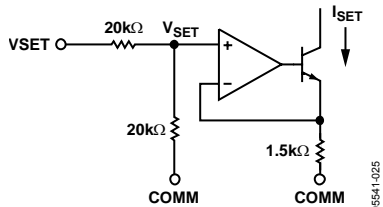

Figure 14. VST[A, B] Interface Simplified Schematic

The slope is given by $-I_D \times 2x \times 1.5 \text{ k}\Omega = -22 \text{ mV/dB} \times x$. For example, if a resistor divider to ground is used to generate a V_{SET} voltage of V_{OUT}/2, then x = 2. The slope is set to -880 V/decade or -44 mV/dB.

OUTPUT INTERFACE, OUT[A, B]

The OUT[A,B] pin is driven by a PNP output stage. An internal 10 Ω resistor is placed in series with the output and the OUT[A,B] pin. The rise time of the output is limited mainly by the slew on CLP[A,B]. The fall time is an RC-limited slew given by the load capacitance and the pull-down resistance at OUT[A,B]. There is an internal pull-down resistor of 1.6 kΩ. A resistive load at OUT[A,B] is placed in parallel with the internal pull-down resistor to provide additional discharge current.

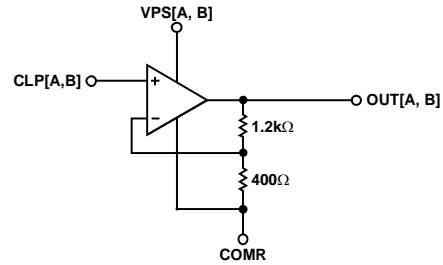

Figure 15. OUT[A, B] Interface Simplified Schematic

OUT[A, B] can source and sink up to 2.2 mA.

DIFFERENCE OUTPUT, OUT[P, N]

The ADL5519 incorporates two operational amplifiers with rail-to-rail output capability to provide a channel difference output.

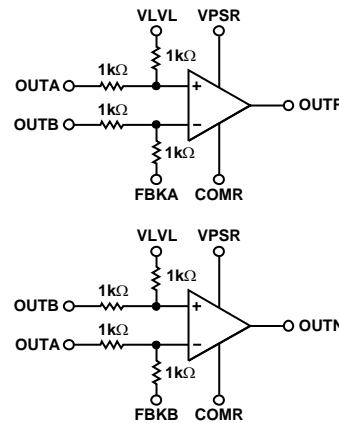

Figure 16. OUT[P, N] Interface Simplified Schematic

As in the case of the output drivers for OUT[A, B], the output stages have the capability of driving 2.2 mA. OUTA and OUTB are internally connected through 1 kΩ resistors to the inputs of each op amp. The pin VLVL is connected to the positive terminal of both op amps through 1 kΩ resistors to provide level shifting. The negative feedback terminal is also made available through a 1 kΩ resistor. The input impedance of VLVL is 1 kΩ and FBK[A, B] is 2 kΩ. See Figure 17 for the connections of these pins.

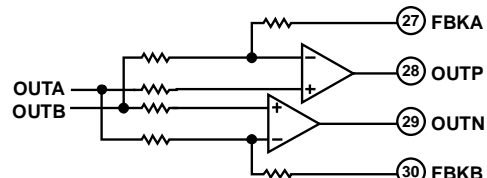

Figure 17. Op Amp Connections (All Resistors are 1 kΩ ± 20%)

If OUTP is connected to FBKA, then OUTP is given as

$$OUTP = OUTA - OUTB + VLVL \tag{9}$$

If OUTN is connected to FBKB, then OUTN is given as

$$OUTN = OUTB - OUTA + VLVL \tag{10}$$

In this configuration, all four measurements, OUT[A, B, P, N], are made available simultaneously. A differential output can be taken from OUTP – OUTN, and VLVL can be used to adjust the common-mode level for an ADC connection.

MEASUREMENT MODE

The ADL5519 requires a single supply of 3.0 V to 5 V. The supply is connected to the three supply pins, VP_{SA}, VP_{SB}, and VP_{SR}. Each pin should be decoupled using the two capacitors with values equal or similar to those shown in Figure 19. These capacitors must provide a low impedance over the full frequency range of the input, and they should be placed as close as possible to the positive supply pins. Two different capacitors are used in parallel to provide a broadband ac short to ground.

The device is placed in measurement mode by connecting OUTA and/or OUTB to VSTA and/or VSTB, respectively. As seen in Figure 18, the ADL5519 has an offset voltage, a negative slope, and a $V_{OUT[A,B]}$ measurement intercept at the high end of its input signal range.

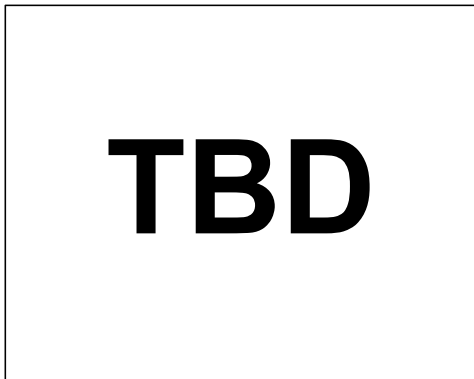

Figure 18. Typical Output Voltage vs. Input Signal, Single Channel

The output voltage vs. input signal voltage of the ADL5519 is linear-in-dB over a multidecade range. The equation for this function is of the form

$$V_{OUT} = X \times V_{SLOPE/DEC} \times \log_{10}(V_{IN}/V_{INTERCEPT}) = \quad (1)$$

$$X \times V_{SLOPE/DB} \times 20 \times \log_{10}(V_{IN}/V_{INTERCEPT}) \quad (2)$$

where:

X is the feedback factor in $V_{SET} = V_{OUT}/X$.

$V_{SLOPE/DEC}$ is nominally -440 mV/decade or -22 mV/dB.

$V_{INTERCEPT}$ is the x-axis intercept of the linear-in-dB portion of the V_{OUT} vs. V_{IN} curve (Figure 18).

$V_{INTERCEPT}$ is $+2$ dBV for a sinusoidal input signal.

An offset voltage, V_{OFFSET} , of 0.35 V is internally added to the detector signal, so that the minimum value for V_{OUT} is $X \times V_{OFFSET}$. So for $X = 1$, minimum V_{OUT} is 0.35 V.

The slope is very stable vs. process and temperature variation. When base-10 logarithms are used, $V_{SLOPE/DECADE}$ represents the volts/decade. A decade corresponds to 20 dB; $V_{SLOPE/DECADE}/20 = V_{SLOPE/DB}$ represents the slope in volts/dB.

As noted in Equation 1 and Equation 2, the V_{OUT} voltage has a *negative* slope. This is also the correct slope polarity to control the gain of many power amplifiers in a negative feedback configuration. Because both the slope and intercept vary slightly with frequency, it is recommended to refer to the Specifications section for application-specific values for slope and intercept.

Although demodulating log amps respond to input signal voltage, not input signal power, it is customary to discuss the amplitude of high frequency signals in terms of power. In this case, the characteristic impedance of the system, Z_0 , must be known to convert voltages to their corresponding power levels. The following equations are used to perform this conversion:

$$P(\text{dBm}) = 10 \times \log_{10}(V_{rms}^2/(Z_0 \times 1 \text{ mW})) \quad (3)$$

$$P(\text{dBV}) = 20 \times \log_{10}(V_{rms}/1 \text{ V}_{rms}) \quad (4)$$

$$P(\text{dBm}) = P(\text{dBV}) - 10 \times \log_{10}(Z_0 \times 1 \text{ mW}/1 \text{ V}_{rms}^2) \quad (5)$$

For example, $P_{INTERCEPT}$ for a sinusoidal input signal expressed in terms of dBm (decibels referred to 1 mW), in a 50Ω system is

$$P_{INTERCEPT}(\text{dBm}) = P_{INTERCEPT}(\text{dBV}) - 10 \times \log_{10}(Z_0 \times 1 \text{ mW}/1 \text{ V}_{rms}^2) = \quad (6)$$

$$+2 \text{ dBV} - 10 \times \log_{10}(50 \times 10^{-3}) = +15 \text{ dBm}$$

For a square wave input signal in a 200Ω system,

$$P_{INTERCEPT} = -1 \text{ dBV} - 10 \times \log_{10}[(200 \Omega \times 1 \text{ mW}/1 \text{ V}_{rms}^2)] = +6 \text{ dBm}$$

Further information on the intercept variation dependence upon waveform can be found in the AD8313 and AD8307 data sheets.

As the input signal to Channel A and Channel B are swept over their nominal input dynamic range of $+10$ dBm to -50 dBm, the output swings from 0.5 V to 1.75 V. The voltages OUTA and OUTB are also internally applied to a difference amplifier with a gain of two. So as the dB difference between INA and INB ranges from approximately -30 dB to $+30$ dB, the difference voltage on OUTP and OUTN swings from 0.5 V to 1.75 V.

Input differences larger than ± 30 dB can be measured as long as the absolute input level at INA and INB are within their nominal ranges of $+10$ dBm to -50 dBm. However, measurement of large differences between INA and INB are affected by on-chip signal leakage. The common-mode level of OUTP and OUTN is set by the voltage applied to VLVL. These output can be easily biased up to a common-mode voltage of 2.5 V by connecting VREF to VLVL. As the gain range is swept, OUTP swings from approximately 0.5 V to 1.75 V and OUTN swings from 1.75 V to 0.5 V.

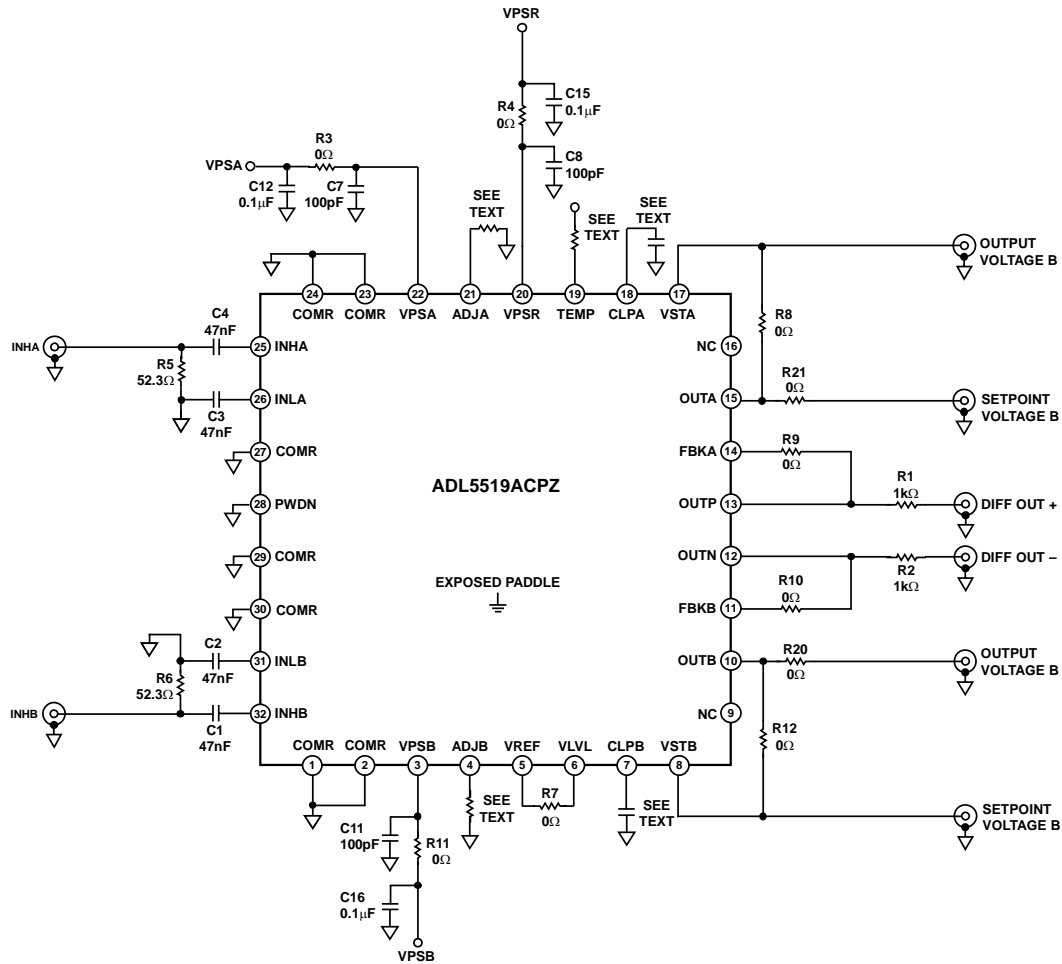

Figure 19. Basic Connections for Operation in Measurement Mode

CONTROLLER MODE

In addition to being a measurement device, the ADL5519 can also be configured to measure and control signal levels. The ADL5519 has two controller modes. Each of the two log detectors can be separately configured to set and control the output power level of a variable gain amplifier (VGA) or variable voltage attenuator (VVA). Alternatively, the two log detectors can be configured to measure and control the gain of an amplifier or signal chain.

The channel difference outputs can be used for controlling a feedback loop to the ADL5519’s RF inputs. A capacitor connected between FBKA and OUTP forms an integrator, keeping in mind that the on-chip 1 kΩ feedback resistor forms a zero. (The value of the on-chip resistors can vary as much as ±20% with manufacturing process variation.) If Channel A is driven and Channel B has a feedback loop from OUTP through a PA, then OUTP integrates to a voltage value such that

$$OUTB = (OUTA + VLVL)/2 \tag{11}$$

The output value from OUTN may or may not be useful. It is given by

$$OUTN = 0 \text{ V} \tag{12}$$

For $VLVL < OUTA/3$,

Otherwise,

$$OUTN = (3 \times VLVL - OUTA)/2 \tag{13}$$

If VLVL is connected to OUTA, then OUTB is forced to equal OUTA through the feedback loop. This flexibility provides the user with the capability to measure one channel operating at a given power level and frequency while forcing the other channel to a desired power level at another frequency. ADJA and ADJB should be set to different voltage levels to reduce the temperature drift of the output measurement. The temperature drift will be statistical sum of the drift from Channel A and Channel B. As stated before, VLVL can be used to force the slaved channel to operate at a different power than the other channel. If the two channels are forced to operate at different power levels, then some static offset occurs due to voltage drops across metal wiring in the IC.

If an inversion is necessary in the feedback loop, OUTN can be used as the integrator by placing a capacitor between OUTN

and OUTP. This changes the output equation for OUTB and OUTP to

$$OUTB = 2 \times OUTA - VLVL \quad (14)$$

For $VLVL < OUTA/2$,

$$OUTN = 0 \text{ V} \quad (15)$$

Otherwise,

$$OUTN = 2 \times VLVL - OUTA \quad (16)$$

The previous equations are valid when Channel A is driven and Channel B is slaved through a feedback loop. When Channel B is driven and Channel A is slaved, the above equations can be altered by changing OUTB to OUTA and OUTN to OUTP.

Automatic Power Control

Figure 20 shows how the device should be reconfigured to control output power.

The RF input to the device is configured as before. A directional coupler taps off some of the power being generated by the VGA (typically a 10 dB to 20 dB coupler is used). A power splitter can be used instead of a directional coupler if there are no concerns about reflected energy from the next stage in the signal chain. Some additional attenuation may be required to set the maximum input signal at the ADL5519 to be equal to the recommended maximum input level for optimum linearity and temperature stability at the frequency of operation.

VSTA and OUTA are no longer shorted together. OUTA now provides a bias or gain control voltage to the VGA. The gain control sense of the VGA must be positive and monotonic, that is, increasing voltage tends to increase gain. However, the gain control transfer function of the device does not need to be well controlled or particularly linear. If the gain control sense of the VGA is negative, an inverting op amp circuit with a dc offset shift can be used between the ADL5519 and the VGA to keep the gain control voltage in the 0 V to 5 V range.

VSTA becomes the setpoint input to the system. This can be driven by a DAC, as shown in Figure 20, if the output power is expected to vary, or it can simply be driven by a stable reference voltage if constant output power is required. This DAC should have an output swing that covers the 0 V to 3.5 V range. The AD7391 and AD7393 serial-input and parallel-input 10-bit DACs provide adequate resolution (4 mV/bit) and an output swing up to 4.5 V.

When VSTA is set to a particular value, the ADL5519 compares this value to the equivalent input power present at the RF input. If these two values do not match, OUTA increases or decreases in an effort to balance the system. The dominant pole of the error amplifier/integrator circuit that drives OUTA is set by the capacitance on Pin CLPA; some experimentation may be necessary to choose the right value for this capacitor. In general,

CLPA should be chosen to provide stable loop operation for the complete output power control range. If the slope (in dB/V) of the gain control transfer function of the VGA is not constant, CLPA must be chosen to guarantee a stable loop when the gain control slope is at its maximum. On the other hand, CLPA must provide adequate averaging to the internal low range squaring detector so that the rms computation is valid. Larger values of CLPA tend to make the loop less responsive.

The relationship between VSTA and the RF input follows from the measurement mode behavior of the device. For example, from Figure 8, which shows the measurement mode transfer function at 880 MHz, it can be seen that an input power of -10 dBm yields an output voltage of 2.5 V. Therefore, in controller mode, VSTA should be set to 2.5 V, which results in an input power of -10 dBm to the ADL5519.

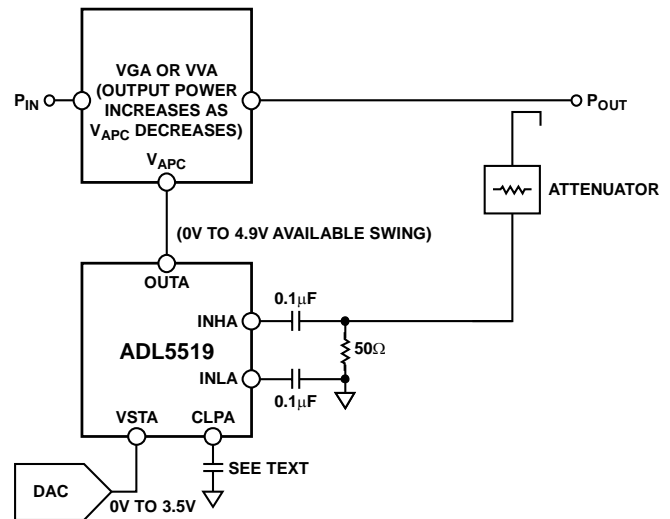

Figure 20. Operation in Controller Mode for Automatic Power Control

Automatic Gain Control

Figure 21 shows how the ADL5519 can be connected to provide automatic gain control to an amplifier or signal chain.

Additional pins are omitted for clarity. In this configuration, both log detectors are connected in measurement mode with appropriate filtering being used on CLP[A, B]. OUTA, however, is also connected to the VLVL pin of the on-board difference amplifier. Also, the OUTP output of the difference amplifier drives a variable gain element (either VVA or VGA) and is connected back to the FBKA input via a capacitor so that it is operating as an integrator.

Assume that OUTA is much bigger than OUTB. Because OUTA also drives VLVL, this voltage is also present on the noninverting input of the op amp driving OUTP. This results in a net current flow from OUTP through the integrating capacitor into the FBKA input. This results in the voltage on OUTP decreasing. If the gain control transfer function of the VVA/VGA is negative, this increases the gain, which in turn increases the input signal to INHB. The output voltage on the integrator continues to

increase until the power on the two input channels is equal, resulting in a signal chain gain of unity.

If a gain other than 0 dB is required, an attenuator can be used in one of the RF paths, as shown in Figure 21. Alternatively, power splitters or directional couplers of different coupling factors can be used. Another convenient option is to apply a voltage on VLVL other than OUTA. Refer to Equation 11 and the Controller Mode section for more detail.

If the VGA/VVA has a positive gain control sense, the OUTN output of the difference amplifier can be used with the integrating capacitor tied back to FBKB.

The choice of the integrating capacitor affects the response time of the AGC loop. Small values give a faster response time but can result in instability, whereas larger values reduce the response time. Note that in this mode, the capacitors on CLPA and CLPB, which perform the rms averaging function, must still be used and also affect the loop response time.

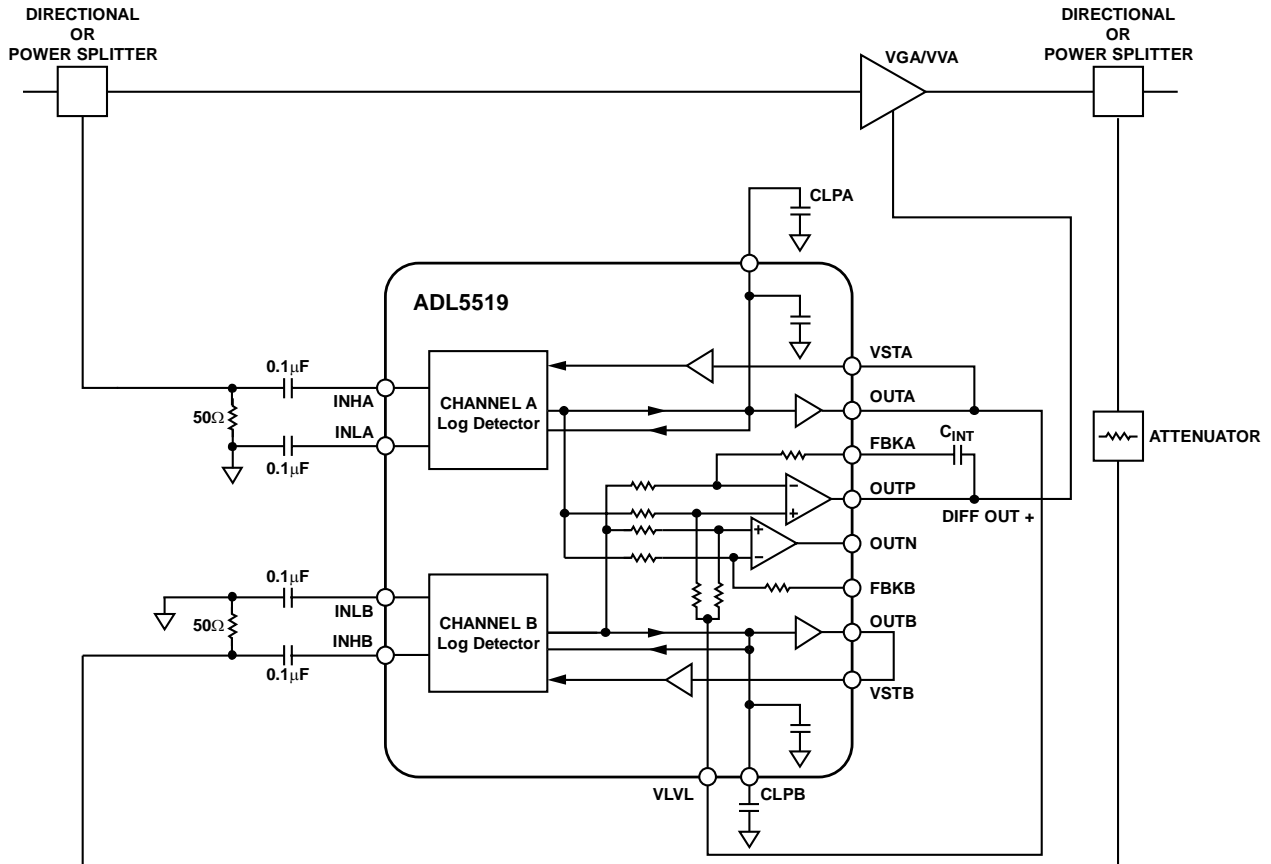

Figure 21. Operation in Controller Mode for Automatic Gain Control

TEMPERATURE COMPENSATION ADJUSTMENT

The ADL5519 has a highly stable measurement output with respect to temperature. However, when the RF inputs exceed a frequency of 600 MHz, the output temperature drift must be compensated for using ADJ[A, B] for optimal performance. Proprietary techniques are used to compensate for the temperature drift. The absolute value of compensation varies with frequency and circuit board material. Table 4 shows recommended voltages for ADJ[A, B] to maintain a temperature drift error of typically ±0.5 dB or better over the entire rated temperature range with the recommended baluns.

Table 4: Recommended ADJ[A,B] Voltage Levels

Frequency	Recommended ADJ[A,B] Voltage
50 MHz	TBD
100 MHz	TBD
900 MHz	TBD
1.8 GHz	TBD
1.9 GHz	TBD
2.2 GHz	TBD
3.6 GHz	TBD
5.3 GHz	TBD
5.8 GHz	TBD
8 GHz	TBD

Compensating the device for temperature drift using ADJ[A, B] allows for great flexibility. If the user requires minimum temperature drift at a given input power or subset of the dynamic range, the ADJ[A, B] voltage can be swept while monitoring OUT[A, B] over temperature. Figure 22 shows the result of such an exercise. The value of ADJ[A, B] where the output has minimum movement (approximately 0.77 V for the example in Figure 22) is the recommended voltage for ADJ[A, B] to achieve minimum temperature drift at a given power and frequency.

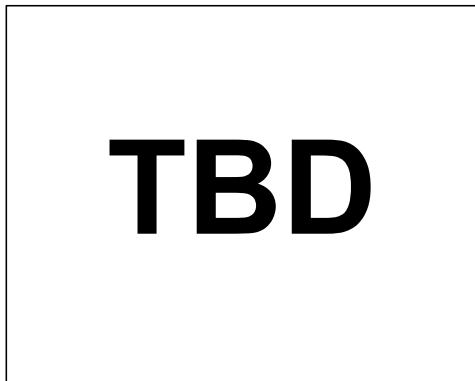

Figure 22. OUTA vs. ADJA over Temp. Pin = -30 dBm, 1.9 GHz

The ADJ[A, B] input has high input impedance. The input can be conveniently driven from an attenuated value of VREF using a resistor divider, if desired.

Figure 23 shows a simplified schematic representation of the ADJ[A, B] interface.

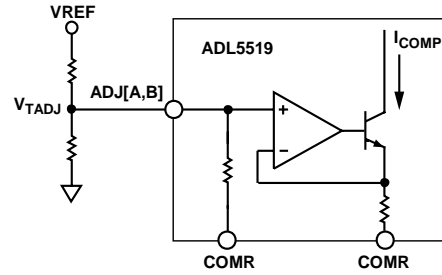

Figure 23. ADJ[A, B] Interface Simplified Schematic

DEVICE CALIBRATION AND ERROR CALCULATION

The measured transfer function of the ADL5519 at 2.14 GHz is shown in Figure 24. The figure shows plots of both output voltage vs. input power and calculated error vs. input power. As the input power varies from -50 dBm to 0 dBm, the output voltage varies from 0.4 V to about 2.8 V.

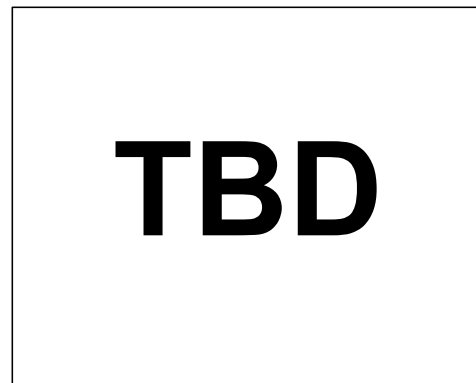

Figure 24. Transfer Function at 2.14 GHz.

Because slope and intercept vary from device to device, board-level calibration must be performed to achieve high accuracy. The equation for output voltage can be written as

$$V_{OUT} = Slope \times (P_{IN} - Intercept)$$

Where *Slope* is the change in output voltage divided by the change in power (dB), and *Intercept* is the calculated power at which the output voltage would be 0 V. (Note that *Intercept* is a theoretical value; the output voltage can never achieve 0 V).

In general, the calibration is performed by applying two known signal levels to the ADL5519's input and measuring the corresponding output voltages. The calibration points are generally chosen to be within the linear-in-dB operating range of the device (see the Specifications section for more details).

Calculation of the slope and intercept is done using the equations:

$$Slope = (V_{OUT1} - V_{OUT2}) / (P_{IN1} - P_{IN2})$$

$$Intercept = P_{IN1} - (V_{OUT1} / Slope)$$

Once slope and intercept have been calculated, an equation can be written that will allow calculation of the input power based on the output voltage of the detector.

$$P_{IN} (unknown) = (V_{OUT1(measured)}/Slope) + Intercept$$

The log conformance error of the calculated power is given by

$$Error (dB) = (V_{OUT(MEASURED)} - V_{OUT(IDEAL)})/Slope$$

Figure 24 includes a plot of the error at 25°C, the temperature at which the log amp is calibrated. Note that the error is not zero. This is because the log amp does not perfectly follow the ideal V_{OUT} vs. P_{IN} equation, even within its operating region. The error at the calibration points (-43 dBm and -23 dBm in this case) will, however, be equal to zero by definition.

Figure 24 also includes error plots for the output voltage at -40°C and +85 °C. These error plots are calculated using the slope and intercept at 25°C. This is consistent with calibration in a mass-production environment, where calibration at temperature is not practical.

ALTERING THE SLOPE

None of the changes to operating conditions discussed so far affect the logarithmic slope, V_{SLOPE} , in Equation 7. The slope can readily be altered by controlling the fraction of $OUT[A, B]$ that is fed back to the setpoint interface at the $VST[A, B]$ pin. When the full signal from $OUT[A, B]$ is applied to $VST[A, B]$, the slope assumes its nominal value of -22 mV/dB. It can be increased by including a voltage divider between these pins, as shown in Figure 25. Moderately low resistance values should be used to minimize scaling errors due to the approximately 40 kΩ input resistance at the $VST[A, B]$ pin. Keep in mind that this resistor string also loads the output, and it eventually reduces the load-driving capabilities if very low values are used. Equation 17 can be used to calculate the resistor values.

$$R1 = R2' (S_D/-22 - 1) \tag{17}$$

where:

S_D is the desired slope, expressed in mV/dB.

$R2'$ is the value of $R2$ in parallel with 40 kΩ.

For example, using $R1 = 1.65$ kΩ and $R2 = 1.69$ kΩ ($R2' = 1.62$ kΩ), the nominal slope is increased to -44 mV/dB.

Operating at a high slope is useful when it is desired to measure a particular section of the input range in greater detail.

When the slope is raised by some factor, the loop capacitor, $CLP[A, B]$, should be raised by the same factor to ensure stability and to preserve a chosen averaging time. The slope can be lowered by placing a voltage divider after the output pin, following standard practice.

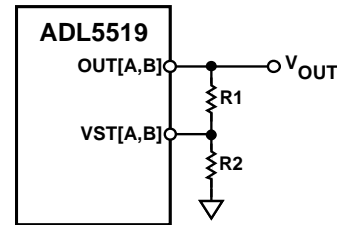

Figure 25. External Network to Raise Slope

OUTPUT FILTERING

Accurate power detection for signals with RF bursts is achieved when the ADL5519 is able to respond quickly to the change in RF power. For applications in which maximum video bandwidth and, consequently, fast rise time are desired, it is essential that the $CLP[A,B]$ pin be left unconnected and free of any stray capacitance.

The nominal output video bandwidth of 50 MHz can be reduced by connecting a ground-referenced capacitor (C_{FLT}) to the $CLPF$ pin, as shown in Figure 26. This is generally done to reduce output ripple (at twice the input frequency for a symmetric input waveform such as sinusoidal signals).

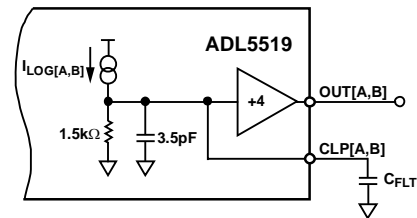

Figure 26. Lowering the Postdemodulation Bandwidth

C_{FLT} is selected using the following equation:

$$C_{FLT} = \frac{1}{(\pi \times 1.5 \text{ k}\Omega \times \text{Video Bandwidth})} - 3.5 \text{ pF} \tag{10}$$

The video bandwidth should typically be set to a frequency equal to about one-tenth the minimum input frequency. This ensures that the output ripple of the demodulated log output, which is at twice the input frequency, is well filtered.

BASIS FOR ERROR CALCULATIONS

The slope and intercept are derived using the coefficients of a linear regression performed on data collected in its central operating range. Error is stated in two forms: (1) error from linear response to CW waveform and (2) output delta from 25°C performance.

The error from linear response to CW waveform is the decibel difference in output from the ideal output defined by the conversions gain and output reference. This is a measure of the linearity of the device response to both CW and modulated waveforms. The error in dB is calculated by

$$\text{Error (dB)} = \frac{V_{OUT} - \text{Slope} \times (P_{IN} - P_Z)}{\text{Slope}}$$

where P_Z is the x-axis intercept expressed in dBm. This is analogous to the input amplitude that would produce an output of 0 V, if such an output was possible.

Error from the linear response to the CW waveform is not a measure of absolute accuracy, since it is calculated using the

slope and intercept of each device. However, it verifies the linearity and the effect of modulation on the device's response. Similarly, error from 25°C performance uses the 25°C performance of a given device and waveform type as the reference from which all other performance parameters shown alongside it are compared. It is predominantly (and most often) used as a measurement of output variation with temperature.

EVALUATION BOARD

Table 5. Evaluation Board (Rev. A) Configuration Options

Component	Function	Default Conditions
VPOS, GND1, GND2, GND3	Supply and Ground Connections. GND1, GND2, GND3 are internally connected together.	Not applicable
R5, R6, C1, C2, C3, C4	Input Interface. The 52.3 Ω resistor in positions R5 and R6 combine with the ADL5519's internal input impedance to give a broadband input impedance of about 50 Ω . Capacitors C1, C2, C3, and C4 are dc-blocking capacitors. A reactive impedance match can be implemented by replacing R5[R6] with an inductor and C1[C3] and C2[C4] with appropriately valued capacitors.	R5 = 52.3 Ω (Size 0402) C1 = 47 nF (Size 0402) C2 = 47 nF (Size 0402) R6 = 52.3 Ω (Size 0402) C3 = 47 nF (Size 0402) C4 = 47 nF (Size 0402)
R14	Temperature Sensor Interface: The temperature sensor output voltage is available at the test point labeled TEMP.	R14 = 0 Ω (Size 0603)
R13, R17, R18, R19, R27, R28, R29	Temperature Compensation Interface. The internal temperature compensation network is optimized for input signals up to TBD GHz when the voltage applied to the ADJ[A,B] pin is TBD V. This circuit can be adjusted to optimize performance for other input frequencies by changing the value of this voltage. See Table 4 for specific voltage levels. The pads for R27/R28 or R27/R29 can be used for voltage dividers to set the ADJ[A,B] voltages for temperature compensation at different frequencies. The individual log channels can be disabled by installing 0 Ω resistors in positions R18 and R19.	R13 = open (size 0603) R17 = open (size 0603) R18 = 0 Ω (size 0603) R19 = 0 Ω (size 0603) R27 = 0 Ω (size 0603) R28 = open (size 0603) R29 = open (size 0603)
R8, R12, R15, R16, R20, R21, R22, R23, C13, C14	Output Interface—Measurement Mode. In measurement mode, a portion of the output voltage is fed back to Pin VSTA[VSTB] via R8[R12]. The magnitude of the slope of the OUTA[OUTB] output voltage response can be increased by reducing the portion of V_{OUTA} [V _{OUTB}] that is fed back to VSTA[VSTB]. R20[R21] can be used as a back-terminating resistor or as part of a single-pole, low-pass filter.	R8 = 0 Ω (Size 0603) R12 = 0 Ω (Size 0603) R15 = open (Size 0603) R16 = open (Size 0603) R20 = 0 Ω (Size 0603) R21 = 0 Ω (Size 0603) R22 = open (Size 0603) R23 = open (Size 0603) C13 = open (Size 0603) C14 = open (Size 0603)
R8, R12, R22, R23	Output Interface—Controller Mode. In this mode, R8[R12] must be open. In controller mode, the ADL5519 can control the gain of an external component. A setpoint voltage is applied to Pin VSTA[VSTB], the value of which corresponds to the desired RF input signal level applied to the corresponding ADL5519 RF input. A sample of the RF output signal from this variable-gain component is selected, typically via a directional coupler, and applied to ADL5519 RF input. The voltage at Pin OUTA[OUTB] is applied to the gain control of the variable gain element. A control voltage is applied to Pin VSTA[VSTB]. The magnitude of the control voltage can optionally be attenuated via the voltage divider comprising R8[R12] and R22[R23], or a capacitor can be installed in position R22[R23] to form a low-pass filter along with R8[R12].	R8 = 0 Ω (Size 0603) R12 = 0 Ω (Size 0603) R22 = open (Size 0603) R23 = open (Size 0603)
R3, R4, R11, C7, C8, C11, C12, C15, C16	Power Supply Decoupling. The nominal supply decoupling consists of a 100 pF filter capacitor placed physically close to the ADL5519 and a 0.1 μ F capacitor placed nearer to each power supply input pin.	R3 = 0 Ω (Size 0603) R4 = 0 Ω (Size 0603) R11 = 0 Ω (Size 0603) C7 = 100 pF (Size 0603) C8 = 100 pF (Size 0603) C11 = 100 pF (Size 0603) C12 = 0.1 μ F (Size 0603) C15 = 0.1 μ F (Size 0603) C16 = 0.1 μ F (Size 0603)

R1, R2, R9, R10	Output Interface – Difference	R1 = 1K Ω (Size 0603) R2 = 1K Ω (Size 0603) R9 = open (Size 0603) R10 = open (Size 0603)
C9, C10	Filter Capacitor. The low-pass corner frequency of the circuit that drives Pin OUTA[OUTB] can be lowered by placing a capacitor between CLPA[CLPB] and ground. Increasing this capacitor increases the overall rise/fall time of the ADL5519 for pulsed input signals. See the Output Filtering section for more details.	C9 = 100 pF (Size 0603) C10 = 100 pF (Size 0603)

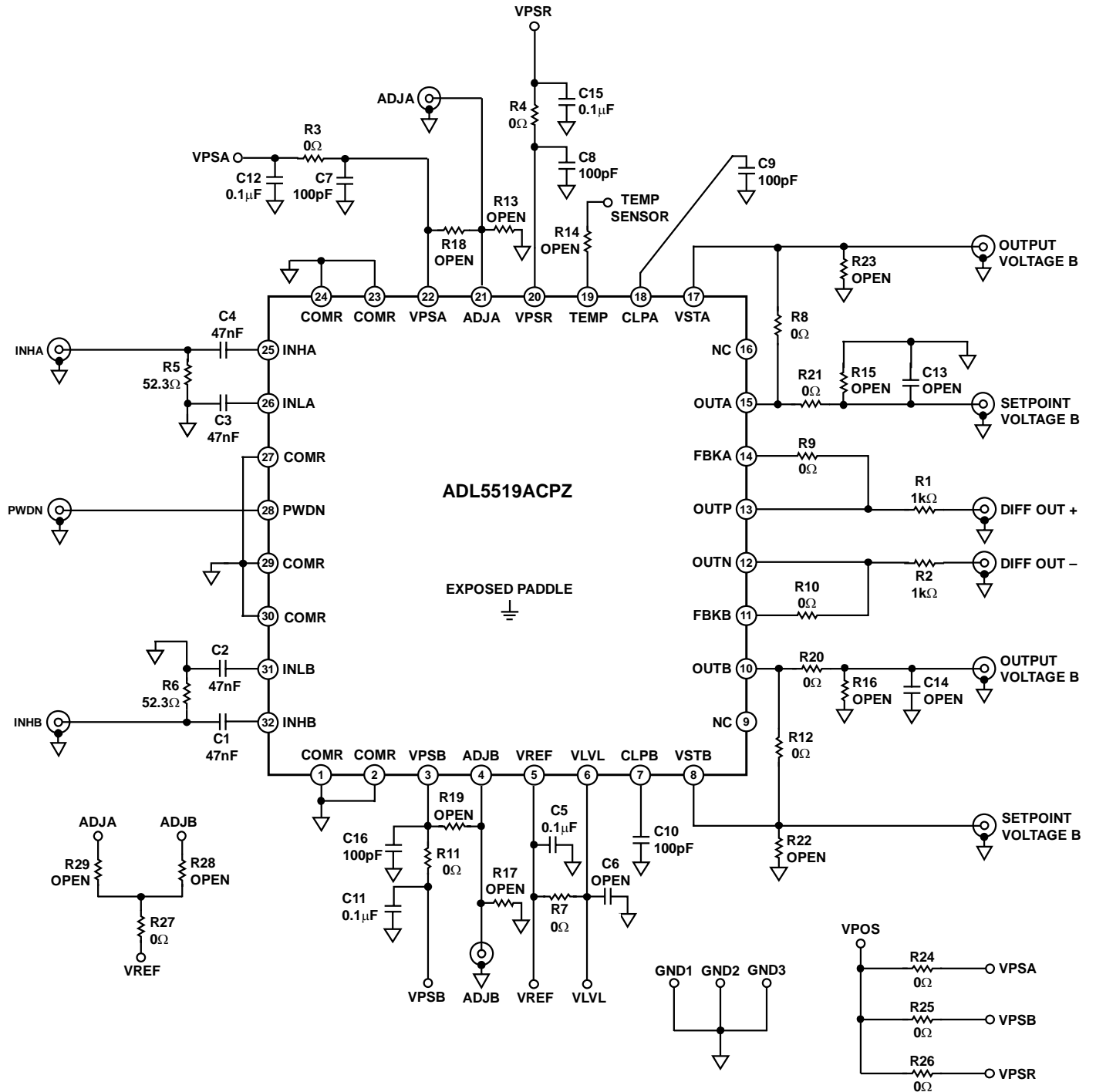

Figure 27. Evaluation Board Schematic

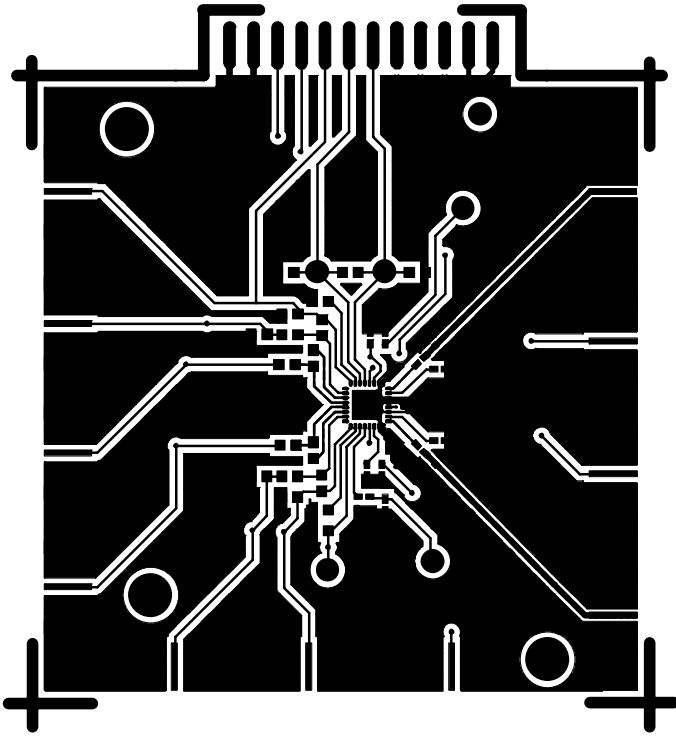

Figure 28. Top Side Layout

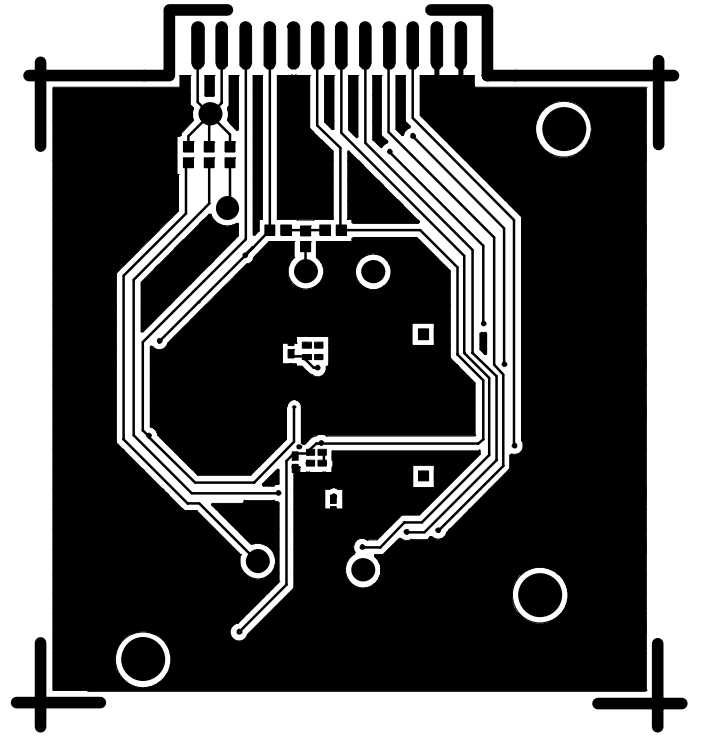

Figure 30: Bottom Side Layout

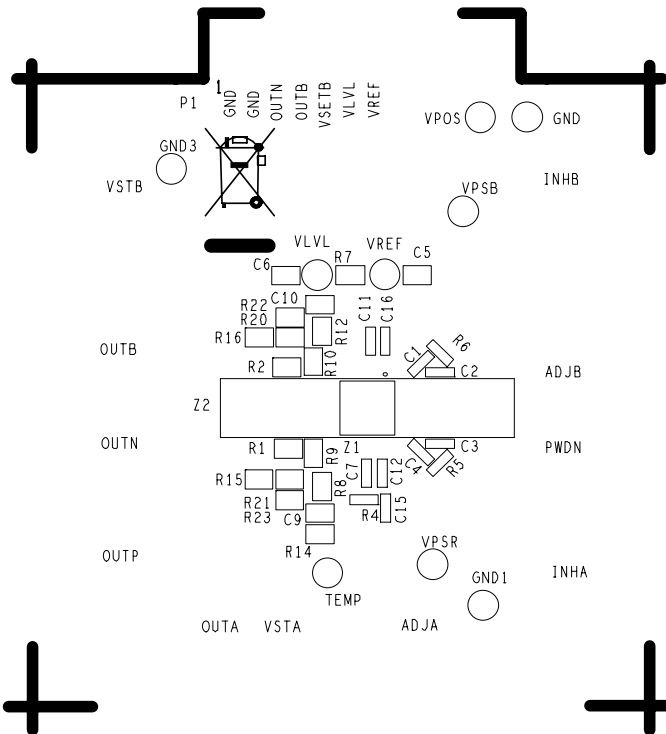

Figure 29. Top Side Silkscreen

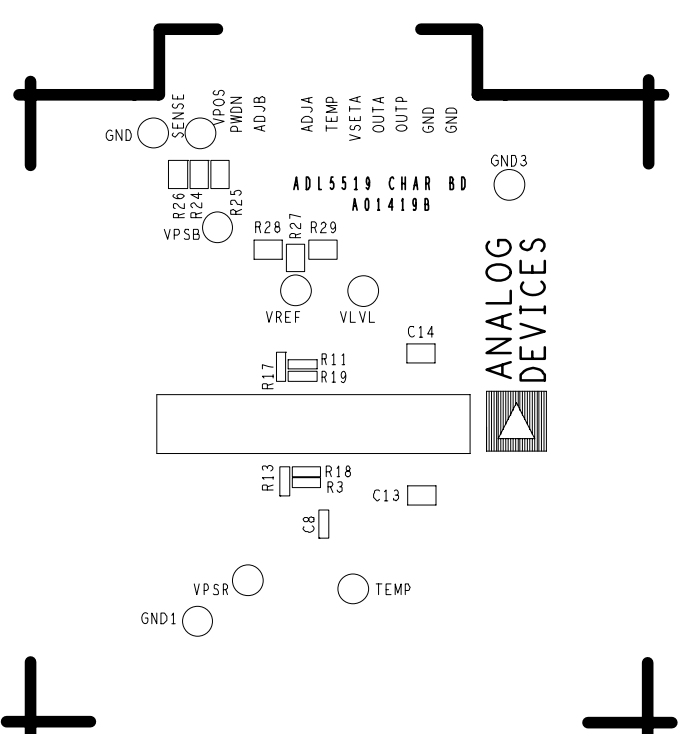
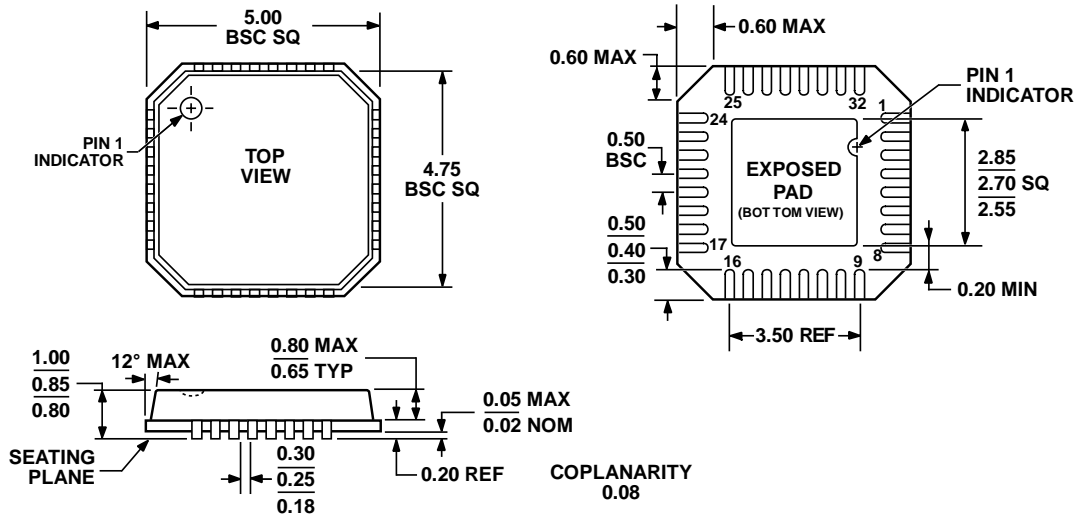

Figure 31: Bottom Side Silkscreen

OUTLINE DIMENSIONS



COMPLIANT TO JEDEC STANDARDS MO-220-VHHD-2

Figure 32. 32-Lead Lead Frame Chip Scale Package [LFCSP_VD]
 5 mm x 5 mm Body, Very Thin, Dual Lead
 (CP-32-8)
 Dimensions shown in millimeters

ORDERING GUIDE

Model	Temperature Package	Package Description	Package Option	Branding
ADL5519ACPZ-R7 ¹	-40°C to +85°C	32-Lead LFCSP_VD	CP-32-8	TBD
ADL5519ACPZ-R2 ¹	-40°C to +85°C	32-Lead LFCSP_VD	CP-32-8	TBD
ADL5519ACPZ-WP ^{1, 2}	-40°C to +85°C	32-Lead LFCSP_VD	CP-32-8	TBD
ADL5519-EVALZ ¹		Evaluation Board		

¹ Z = Pb-free part.
² WP = waffle pack.