

FEATURES

Operation from 2.3 GHz to 4.0 GHz
Gain of +14 dB at 2600 MHz
OIP3 of +40 dBm at 2600 MHz
P1dB of +25 dBm at 2600 MHz
Noise figure of 4 dB at 2600 MHz
Power supply of 5 V
Power supply current of 84 mA
Internal active biasing
Thermally efficient SOT-89 package
The ADL5320 is a 400 MHz to 2700 MHz driver
ESD rating of ± 4 kV (Class 3A)

GENERAL DESCRIPTION

The ADL5321 is a broadband, linear driver RF amplifier that operates at frequencies from 2.3 GHz to 4.0 GHz. The device can be used in a wide variety of wired and wireless applications including LTE, WiMAX, WiBro, and WLL.

The ADL5321 operates with a 5V supply voltage, while only consuming 84 mA of current.

The ADL5321 is fabricated on a GaAs HBT process. The device is packaged in a low-cost SOT-89 that uses an exposed paddle for excellent thermal impedance. It operates from -40°C to $+85^{\circ}\text{C}$, and a fully populated evaluation board is available.

The ADL5320 is a companion part that offers lower frequency operation from 400 MHz to 2700 MHz.

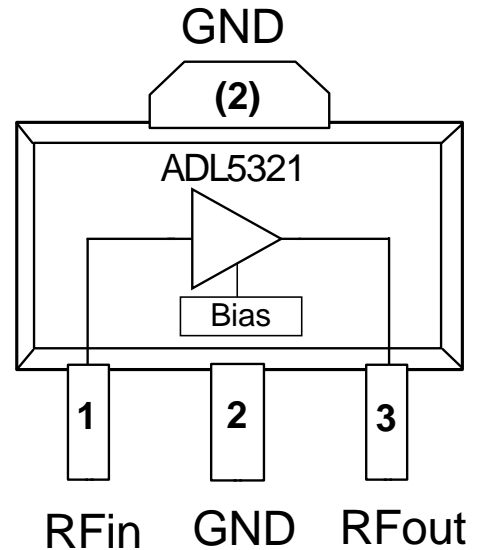
FUNCTIONAL BLOCK DIAGRAM*Figure 1.***Rev. PrB**

Information furnished by Analog Devices is believed to be accurate and reliable. However, no responsibility is assumed by Analog Devices for its use, nor for any infringements of patents or other rights of third parties that may result from its use. Specifications subject to change without notice. No license is granted by implication or otherwise under any patent or patent rights of Analog Devices. Trademarks and registered trademarks are the property of their respective owners.

TABLE OF CONTENTS

Features	1	Pin Configuration and Function Descriptions.....	5
General Description	1	Typical Performance Characteristics	6
Functional Block Diagram	1	Evaluation Board	7
Revision History	2	Outline Dimensions	9
Specifications.....	3	Ordering Guide	9
Absolute Maximum Ratings.....	4		
ESD Caution.....	4		

REVISION HISTORY

1/08—Rev. PrB: Preliminary Version

SPECIFICATIONS

VCC = 5 V and T_A = 25°C, unless otherwise noted.

Table 1.

Parameter	Conditions	Min	Typ	Max	Unit
OVERALL FUNCTION Frequency Range		2.3		4.0	GHz
FREQUENCY = 2600 MHz					
Gain			13.8		dB
vs. Frequency	± 50 MHz		± 0.2		dB
vs. Temperature	-40°C ≤ T _A ≤ +85°C		± 0.8		dB
vs. Supply	4.75 V to 5.25 V		± 0.65		dB
Output 1 dB Compression Point			24.9		dBm
Output Third-Order Intercept	Δf = 1 MHz, Output Power (P _{OUT}) = 10 dBm per tone		39.7		dBm
Noise Figure	VCC = 5 V		4.1		dB
Input Return Loss (S11)			18.3		dB
Output Return Loss (S22)			10.9		dB
Reverse Isolation (S12)			24.5		dB
FREQUENCY = 3700 MHz					
Gain			12.7		dB
vs. Frequency	± 50 MHz		± 0.2		dB
vs. Temperature	-40°C ≤ T _A ≤ +85°C		± 1.1		dB
vs. Supply	4.75 V to 5.25 V		± 0.07		dB
Output 1 dB Compression Point			26.1		dBm
Output Third-Order Intercept	Δf = 1 MHz, P _{OUT} = 10 dBm per tone		34.1		dBm
Noise Figure	VCC = 5 V		5.0		dB
Input Return Loss (S11)			20.6		dB
Output Return Loss (S22)			17.2		dB
Reverse Isolation (S12)			26.4		dB
POWER INTERFACE	Pin RFOUT,				
Supply Voltage		4.75	5	5.25	V
Supply Current			84		mA
vs. Temp	-40°C ≤ T _A ≤ +85°C		97		mA
Power Dissipation	VCC = 5V		420		mW

ABSOLUTE MAXIMUM RATINGS

Table Summary

Table 2.

Parameter	Rating
Supply Voltage, VCC	6 V
Input Power (re: 50 Ω)	+20 dBm
Internal Power Dissipation (Paddle Soldered)	582 mW
θ_{jc} (Junction to Paddle)	TBD $^{\circ}\text{C}/\text{W}$
Maximum Junction Temperature	TBD $^{\circ}\text{C}$
Operating Temperature Range	-40°C to $+85^{\circ}\text{C}$
Storage Temperature Range	-65°C to $+150^{\circ}\text{C}$

Stresses above those listed under Absolute Maximum Ratings may cause permanent damage to the device. This is a stress rating only; functional operation of the device at these or any other conditions above those indicated in the operational section of this specification is not implied. Exposure to absolute maximum rating conditions for extended periods may affect device reliability.

ESD CAUTION



ESD (electrostatic discharge) sensitive device. Charged devices and circuit boards can discharge without detection. Although this product features patented or proprietary protection circuitry, damage may occur on devices subjected to high energy ESD. Therefore, proper ESD precautions should be taken to avoid performance degradation or loss of functionality.

PIN CONFIGURATION AND FUNCTION DESCRIPTIONS

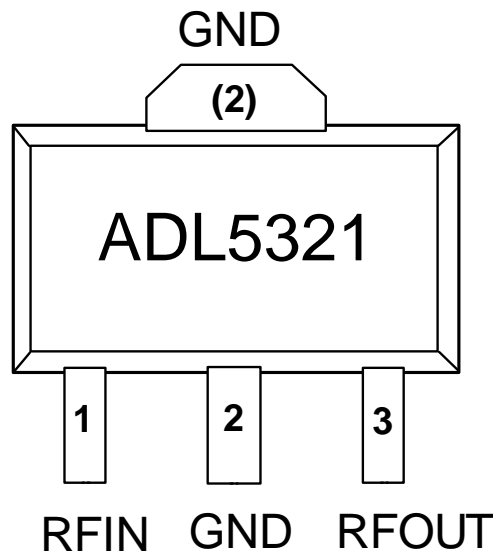

Figure 2.

Table 3. Pin Function Descriptions

Pin No.	Mnemonic	Description
1	RFIN	RF Input. Requires a dc blocking capacitor
2	GND	Ground: Connect to a low impedance ground plane
3	RFOUT	RF Output and Supply Voltage: DC bias is provided to this pin through an inductor that is tied to the external power supply. RF path requires a DC blocking capacitor.
Exposed Paddle		Exposed Paddle: Internally connected to GND. Solder to a low impedance ground plane.

TYPICAL PERFORMANCE CHARACTERISTICS

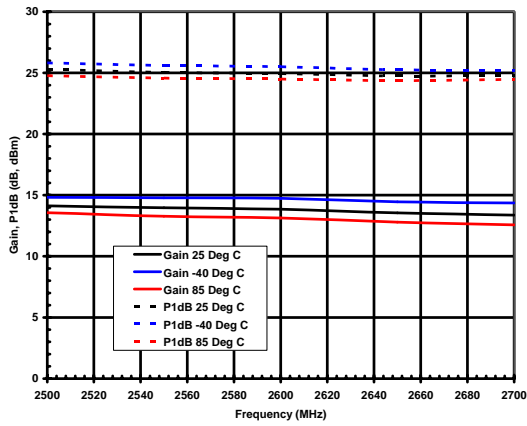

Figure 3. Gain and P1dB vs. Frequency and Temperature 2500 MHz – 2700 MHz

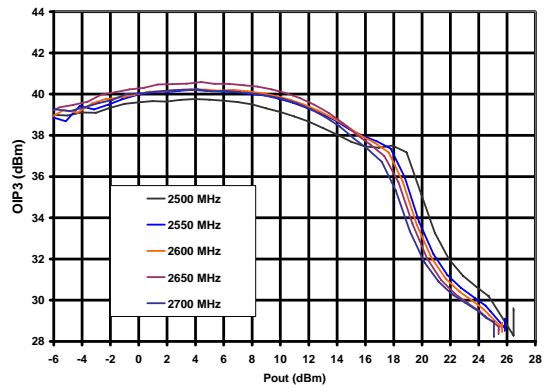

Figure 5. OIP3 vs. Pout and Frequency 2500 MHz – 2700 MHz

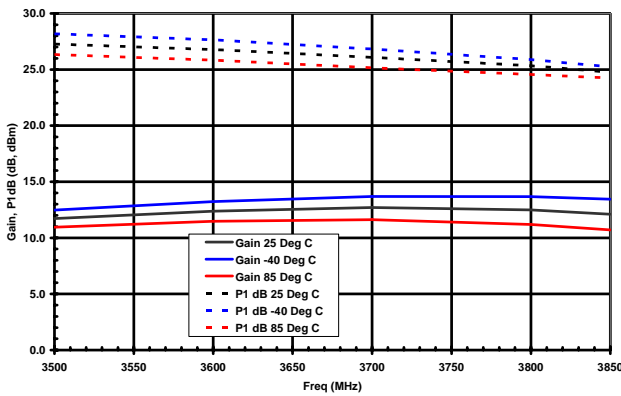

Figure 4. Gain and P1dB vs. Frequency and Temperature 3500 MHz – 3850 MHz
Pout = 10 dBm

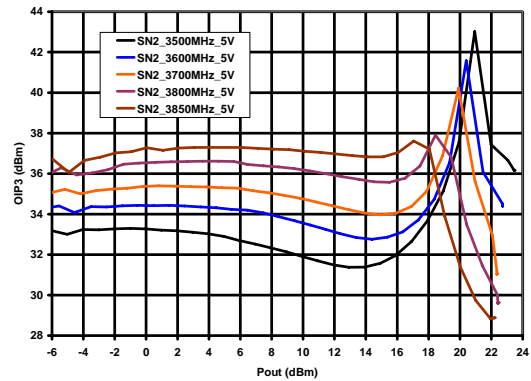

Figure 6. OIP3 vs. Pout and Frequency 3500 MHz – 3850 MHz

EVALUATION BOARD

The basic connections for operating the ADL5321 are shown in Figure 8. The inputs and outputs should be ac coupled with appropriately sized capacitors. DC bias is provided to the amplifier via an inductor connected to the RF output pin. A bias voltage of 5 V is recommended.

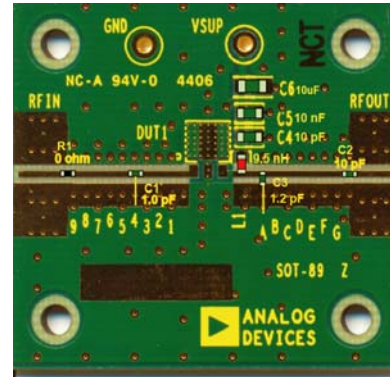

Figure 7. Evaluation Board Layout showing component placement 2500 MHz to 2700 MHz operation

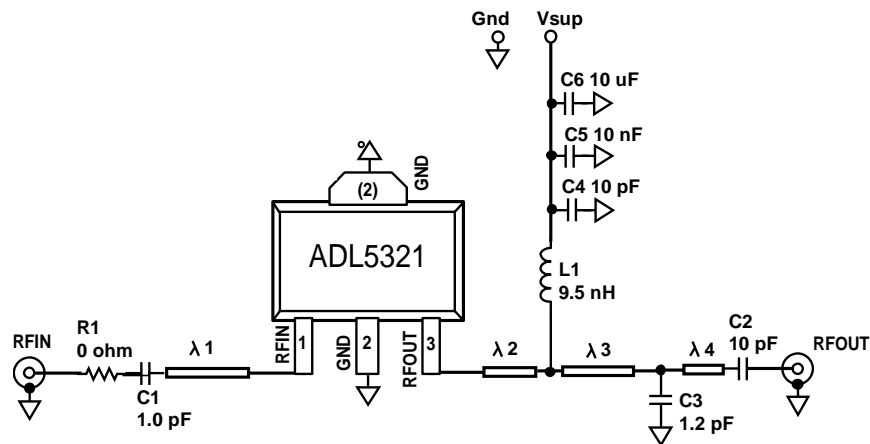

Figure 8. Basic Connections default condition is for 2500 MHz to 2700 MHz

Table 4. Matching Component Spacing 2500 MHz - 2700 MHz

$\lambda 1^1$	$\lambda 2$	$\lambda 3$	$\lambda 4$
240 mils	75 mils	89 mils	325 mils

¹ 50 ohm traces 25 mils wide substrate used is FR4.

Table 5. Evaluation Board Configuration Options 2500 MHz - 2700 MHz

Component	Function	Default Value
R1	jumper	0402 0 ohm
C1	Tuning capacitor	0402 1.0 pF
C2	AC - coupling capacitor	0402 10 pF
C3	Tuning capacitors	C3 0402 1.2 pF
C4, C5, C6	Power supply bypassing capacitors	C4 0603 10 pF C5 0603 10 nF C6 1206 10µF
L1	DC bias inductor	0603 9.5 nH
Vsup, Gnd	Power supply connections	Vsup red testloop Gnd Black testloop

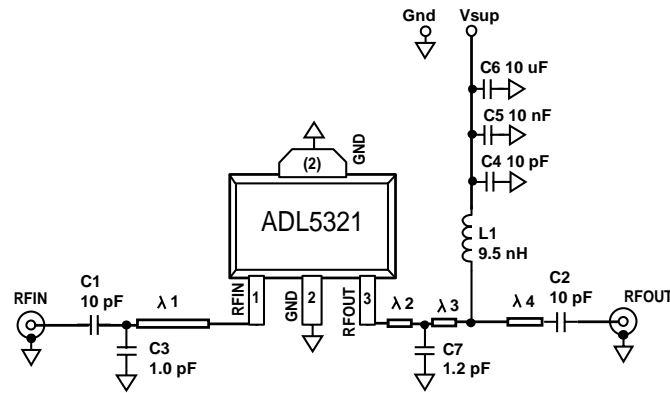

Figure 9. Basic Connections for 3500 MHz to 3850 MHz

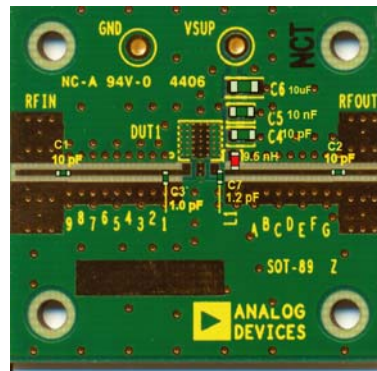

Figure 10. Evaluation Board Layout showing component placement 3500 MHz to 3850 MHz operation

Table 5. Matching Component Spacing 3500 MHz – 3850 MHz

$\lambda 1^1$	$\lambda 2$	$\lambda 3$	$\lambda 4$
90 mils	35 mils	40 mils	416 mils

¹ 50 ohm traces 25 mils wide substrate used is FR4.

Table 6. Evaluation Board Configuration Options 3500 MHz – 3850 MHz

Component	Function	Default Value
C1, C2	AC - coupling capacitors	0402 10 pF
C4, C5, C6	Power supply bypassing capacitors	C4 0603 10 pF C5 0603 10 nF C6 1206 10µF
L1	DC bias inductor	0603 9.5 nH
C3, C7	Tuning capacitors	C3 0402 1.0 pF C7 0402 1.2 pF
Vsup, Gnd	Power supply connections	Vsup red testloop Gnd Black testloop

OUTLINE DIMENSIONS

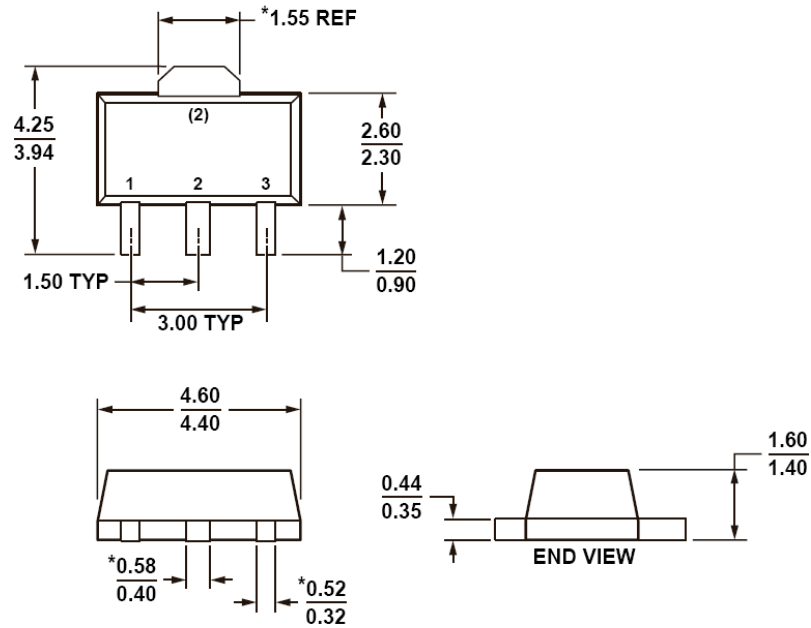

***COMPLIANT TO JEDEC STANDARDS TO-243 WITH EXCEPTION TO DIMENSIONS INDICATED BY AN ASTERISK.**

Figure 11. 3-Lead Small Outline Transistor Package [SOT-89] (RK-3)
Dimensions shown in millimeters

ORDERING GUIDE

Model	Temperature Range	Package Description	Package Option	Branding	Ordering Quantity
ADL5321ARKZ-R7 ¹ ADL5231-EVALZ ¹	-40°C to +85°C	3 Lead SOT89, Tape and Reel Evaluation Board	RK-3	TBD	TBD

¹ Z = RoHS Compliant Part.