

FEATURES

- Internally frequency compensated for unity gain
- Large DC voltage gain : 100dB
- Wide power supply range : 3V~32V(or±1.5V~15V)
- Input common-mode voltage range includes ground
- Large output voltage swing : 0V DC to $V_{CC}-1.5V$ DC
- Power drain suitable for battery operation
- Moisture Sensitivity Level 3

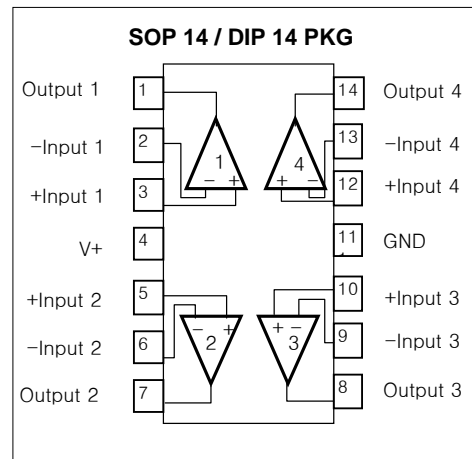

ORDERING INFORMATION

Device	Package
LM324D	14 SOP
LM324N	14 DIP

QUAD OPERATION AMPLIFIERS

LM324 is consists of four independent, high gain, internally frequency compensated operational amplifiers which were designed specifically to operate from a single power supply over a wide voltage range.

Operation from split power supplies is also possible so long as the difference between the two supplies is 3 volts to 32 volts voltage.

Application areas include transducer amplifier, DC gain blocks and all the conventional OP amp circuits which now can be easily implemented in single power supply systems.

EQUIMENT CIRCUIT

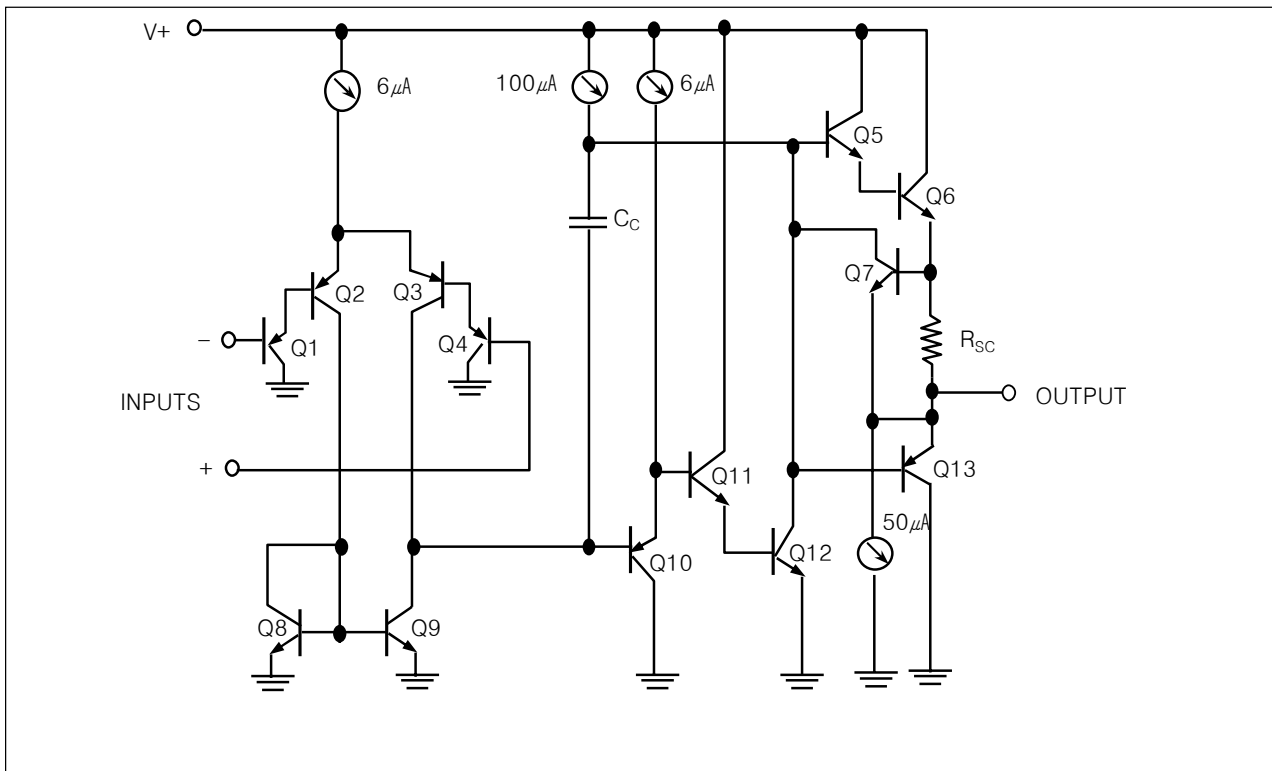

ABSOLUTE MAXIMUM RATINGS

CHARACTERISTIC	SYMBOL	VALUE	UNIT
Power Supply Voltage	V_{CC}	± 18 or 32	V
Differential Input Voltage	$V_{I(DIFF)}$	32	V
Input Voltage	V_I	-0.3 to +32	V
Output Short Circuit to GND $V_{CC} \leq 15V$ $T_A = 25^\circ C$ (One Amp)		Continuous	
Power Dissipation	P_D	570	mW
Operating Temperature Range	T_{OPR}	0~+70	$^\circ C$
Storage Temperature Range	T_{STG}	-65 to +150	$^\circ C$

Electrical characteristics at specified free-air temperature, $V_{CC}=5V$ (unless otherwise noted)

PARAMETER	*TEST CONDITIONS	LM324D			UNIT	
		MIN	TYP	MAX		
V_{IO} Input Offset Voltage	$V_{CC}=5V$ to MAX, $V_{IC}=V_{ICRMIN}$, $V_O=1.4V$	25 $^\circ C$	3	7	mV	
		Full Range		9		
αV_{IO} Average Temperature Coefficient of Input Offset Voltage		Full Range	7		$\mu V / ^\circ C$	
I_{IO} Input Offset Current	$V_O=1.4V$	25 $^\circ C$	2	50	nA	
		Full Range		150		
αI_{IO} Average Temperature Coefficient of Input Offset Current		Full Range	10		pA/ $^\circ C$	
I_{IB} Input Bias Current	$V_O=1.4V$	25 $^\circ C$	-20	-250	nA	
		Full Range		-500		
V_{ICR} Common-Mode Input Voltage Range	$V_{CC}=5V$ to MAX	25 $^\circ C$	0to $V_{CC}-1.5$		V	
		Full Range	0to $V_{CC}-2$			
V_{OH} High-Level Output Voltage	$R_L \geq 2k\Omega$	25 $^\circ C$	$V_{CC}-1.5$		V	
	$V_{CC}=MAX$, $R_L=2k\Omega$	Full Range	26			
	$V_{CC}=MAX$, $R_L \geq 10k\Omega$	Full Range	27	28		
V_{OL} Low-Level Output Voltage	$R_L \geq 10k\Omega$	Full Range	5	20	mV	
A_{VD} Large-Signal Differential Voltage Amplification	$V_{CC}=15V$, $V_O=1V$ to 11V, $R_L \geq 2k\Omega$	25 $^\circ C$	25	100	V/mV	
		Full Range	15			
CMRR Common-Mode Rejection Ratio	$V_{CC}=5V$ to MAX, $V_{IC}=V_{ICRMIN}$,	25 $^\circ C$	65	80	dB	
K_{SVR} Supply Voltage Rejection Ratio($\Delta V_{CC}/\Delta V_{IO}$)	$V_{CC}=5V$ to MAX	25 $^\circ C$	65	100	dB	
V_{O1}/V_{O2} Crosstalk Attenuation	f=1 kHz to 20kHz	25 $^\circ C$		120	dB	
I_O Output Current	$V_{CC}=15V$, $V_{ID}=1V$, $V_O=0$	25 $^\circ C$	-20	-30	mA	
		Full Range	-10			
	$V_{CC}=15V$, $V_{ID}=1V$, $V_O=15V$	25 $^\circ C$	10	20		
		Full Range	5			
I_{OS} Short-Circuit Output Current	V_{CC} at 5V, GND at -5V, $V_O=0$	25 $^\circ C$		± 40	± 60	mA
I_{CC} Supply Current (Four Amplifiers)	$V_O=2.5V$, No Load	Full Range	0.7	1.2	mA	
	$V_{CC}=MAX$, $V_O=0.5V_{CC}$, No load	Full Range	1.1	3		

* All characteristics are measured under open loop conditions with zero common-mode input voltage unless otherwise specified <<MAX>> V_{CC} for testing purpose is 30V. Full range is 0 $^\circ C$ to 70 $^\circ C$.

TYPICAL PERFORMANCE CHARACTERISTICS

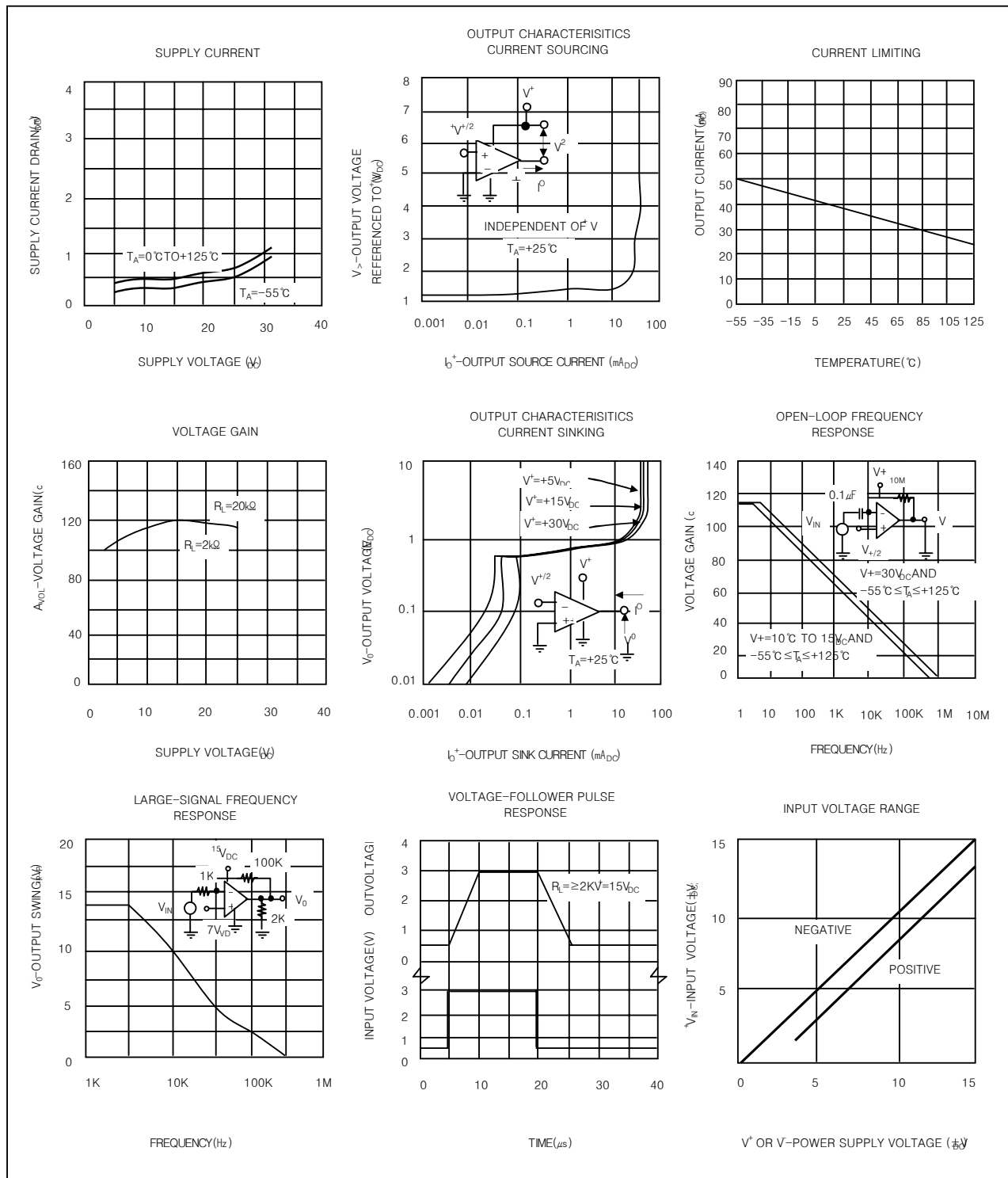

TYPICAL PERFORMANCE CHARACTERISTICS (CONTINUED)

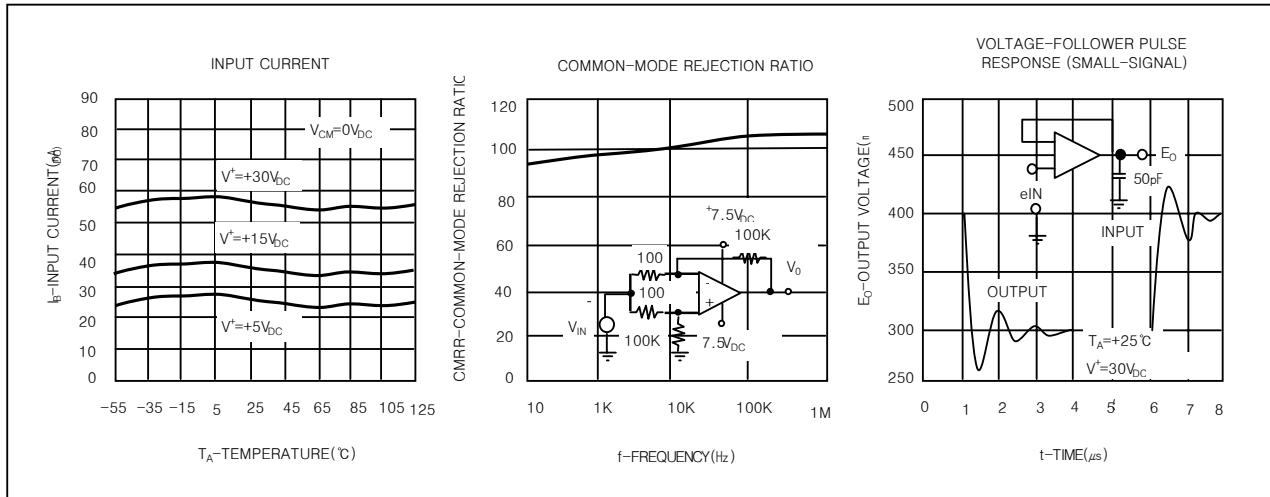

TYPICAL APPLICATIONS

