



LM358

LINEAR INTEGRATED CIRCUIT

DUAL OPERATIONAL AMPLIFIER

DESCRIPTION

The UTC LM358 consists of two independent high gain, internally frequency compensated operational amplifier. It can be operated from a single power supply and also split power supplies.

FEATURES

- *Internally frequency compensated for unity gain.
- *Wide power supply range 3V - 32V.
- *Input common-mode voltage range include ground.
- *Large DC voltage gain.

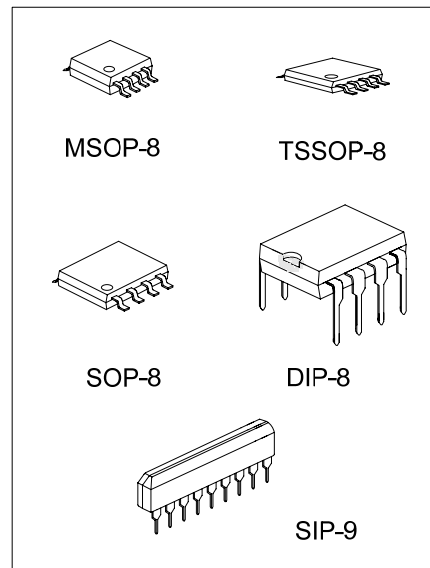

*Pb-free plating product number: LM358L

ORDERING INFORMATION

| Ordering Number | | Package | Packing |
|-----------------|-------------------|---------|-----------|
| Normal | Lead Free Plating | | |
| LM358-D08-T | LM358L-D08-T | DIP-8 | Tube |
| LM358-G09-T | LM358L-G09-T | SIP-9 | Tube |
| LM358-P08-R | LM358L-P08-R | TSSOP-8 | Tape Reel |
| LM358-P08-T | LM358L-P08-T | TSSOP-8 | Tube |
| LM358-S08-R | LM358L-S08-R | SOP-8 | Tape Reel |
| LM358-S08-T | LM358L-S08-T | SOP-8 | Tube |
| LM358-SM1-R | LM358L-SM1-R | MSOP-8 | Tape Reel |
| LM358-SM1-T | LM358L-SM1-T | MSOP-8 | Tube |

| | |
|---|---|
| <p>LM358L-D08-T</p> <p>(1) Packing Type (2) Package Type (3) Lead Plating</p> | <p>(1) R: Tape Reel, T: Tube (2) D08: DIP-8, G09: SIP-9, S08: SOP-8, SM1: MSOP-8, P08: TSSOP-8 (3) L: Lead Free Plating, Blank: Pb/Sn</p> |
|---|---|

■ PIN DESCRIPTION

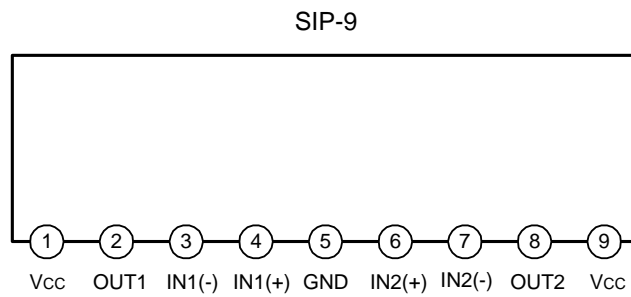
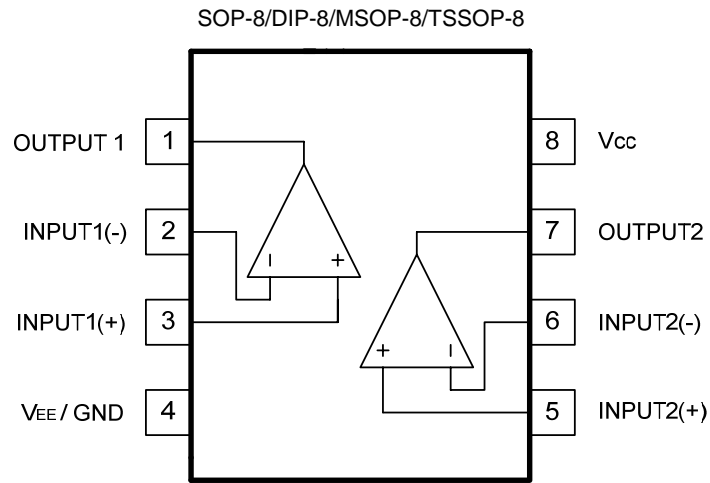

■ BLOCK DIAGRAM

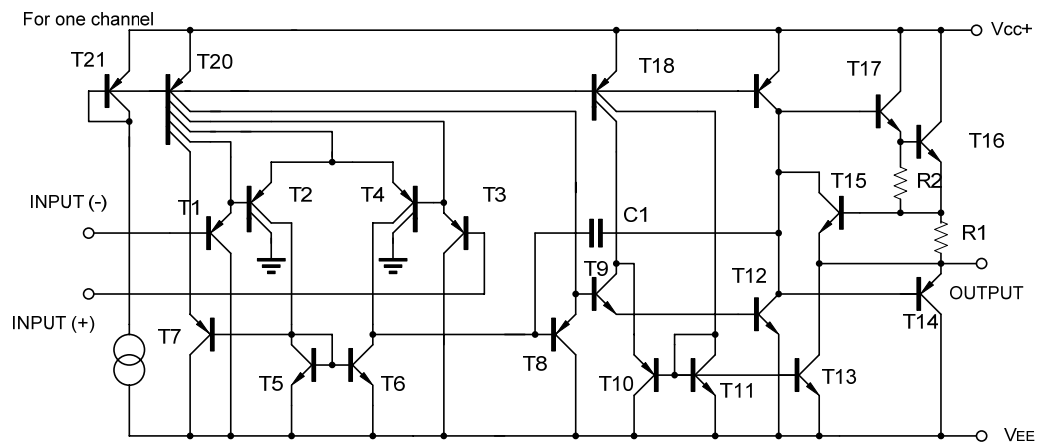

■ ABSOLUTE MAXIMUM RATINGS

| PARAMETER | | SYMBOL | RATINGS | UNIT |
|----------------------------|----------------|---------------|----------------|--------------------|
| Supply Voltage | | V_{CC} | ± 16 or 32 | V |
| Differential Input Voltage | | $V_{I(DIFF)}$ | ± 32 | V |
| Input Voltage | | V_I | -0.3 ~ +32 | V |
| Output Short to Ground | | | Continuous | |
| Power Dissipation | SIP-9 | P_D | 600 | mW |
| | DIP-8 | | 500 | |
| | SOP-8 | | 280 | |
| | TSSOP-8/MSOP-8 | | 200 | |
| Junction Temperature | | T_J | +125 | $^{\circ}\text{C}$ |
| Operating Temperature | | T_{OPR} | 0 ~ +70 | $^{\circ}\text{C}$ |
| Storage Temperature | | T_{STG} | -65 ~ +150 | $^{\circ}\text{C}$ |

Note Absolute maximum ratings are those values beyond which the device could be permanently damaged. Absolute maximum ratings are stress ratings only and functional device operation is not implied.

■ ELECTRICAL CHARACTERISTICS ($V_{CC}=5.0\text{V}$, $V_{EE}=\text{GND}$, $T_a=25^{\circ}\text{C}$, unless otherwise specified)

| PARAMETER | SYMBOL | TEST CONDITIONS | MIN | TYP | MAX | UNIT |
|---------------------------------|---------------|--|-----|-----|--------------|------|
| Input Offset Voltage | $V_{I(OFF)}$ | $V_{CM}=0\text{V}$ to $V_{CC}-1.5\text{V}$ $V_{O(P)}=1.4\text{V}$, $R_S=0\Omega$ | | 2.9 | 7.0 | mV |
| Input Common Mode Voltage | $V_{I(CM)}$ | $V_{CC}=30\text{V}$ | 0 | | $V_{CC}-1.5$ | V |
| Differential Input Voltage | $V_{I(DIFF)}$ | | | | V_{CC} | V |
| Output Voltage Swing | V_{OH} | $V_{CC}=30\text{V}$, $R_L=2\text{K}\Omega$ | 26 | | | V |
| | | $V_{CC}=30\text{V}$, $R_L=10\text{K}\Omega$ | 27 | 28 | | V |
| | V_{OL} | $V_{CC}=5\text{V}$, $R_L \geq 10\text{K}\Omega$ | | 5 | 20 | mV |
| Large Signal Voltage Gain | G_V | $V_{CC}=15\text{V}$, $R_L \geq 2\text{K}\Omega$ $V_{O(P)}=1\text{V} \sim 11\text{V}$ | 25 | 100 | | V/mV |
| Power Supply Current | I_{CC} | $R_L=\infty$, $V_{CC}=30\text{V}$ | | 0.8 | 2.0 | mA |
| | | $R_L=\infty$, Full Temperature Range | | 0.5 | 1.2 | mA |
| Input Offset Current | $I_{I(OFF)}$ | | | 5 | 50 | nA |
| Input Bias Current | $I_{I(BIAS)}$ | | | 45 | 250 | nA |
| Short Circuit Current to Ground | I_{SC} | | | 40 | 60 | mA |
| Output Current | I_{SOURCE} | $V_{I(+)}=1\text{V}$, $V_{I(-)}=0\text{V}$ $V_{CC}=15\text{V}$, $V_{O(P)}=2\text{V}$ | 10 | 30 | | mA |
| | | $V_{I(+)}=0\text{V}$, $V_{I(-)}=1\text{V}$ $V_{CC}=15\text{V}$, $V_{O(P)}=2\text{V}$ | 10 | 15 | | mA |
| | I_{SINK} | $V_{I(+)}=0\text{V}$, $V_{I(-)}=1\text{V}$ $V_{CC}=15\text{V}$, $V_{O(P)}=200\text{mV}$ | 12 | 100 | | mA |
| Common Mode Rejection Ratio | CMRR | | 65 | 80 | | dB |
| Power Supply Rejection Ratio | PSRR | | 65 | 100 | | dB |
| Channel Separation | CS | $f=1\text{KHZ} \sim 20\text{KHZ}$ | | 120 | | dB |

TYPICAL CHARACTERISTICS

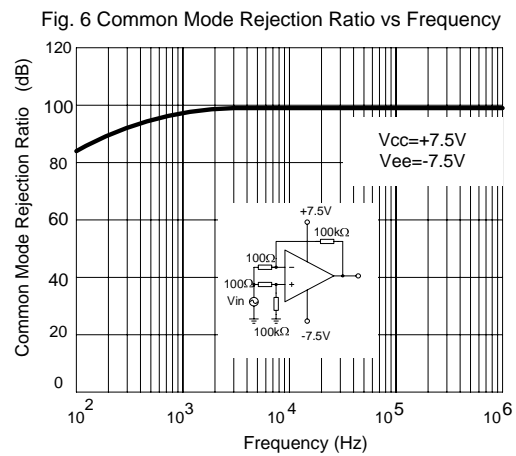
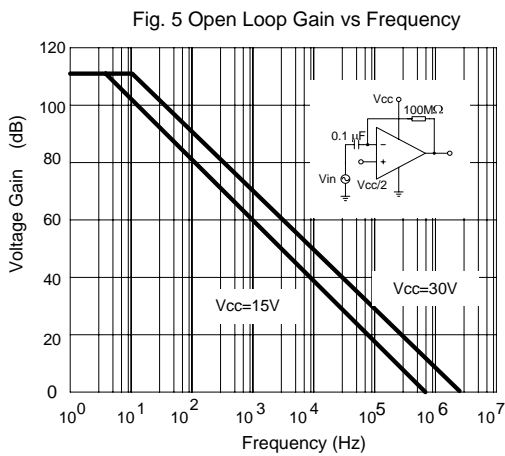
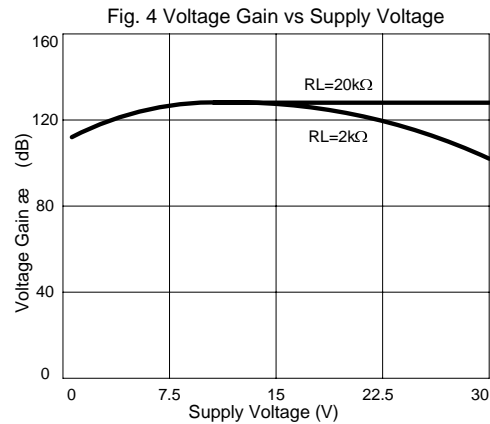
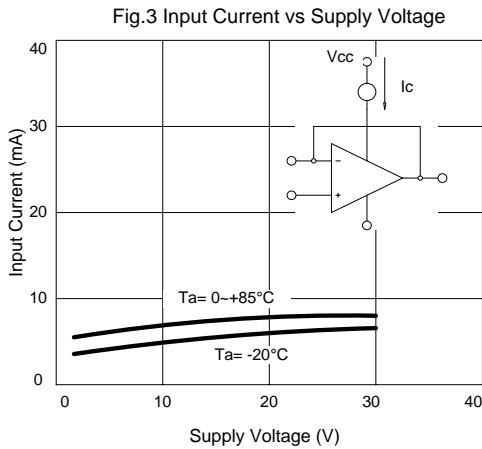
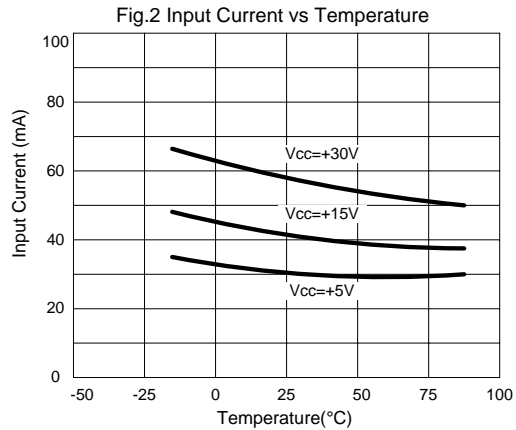
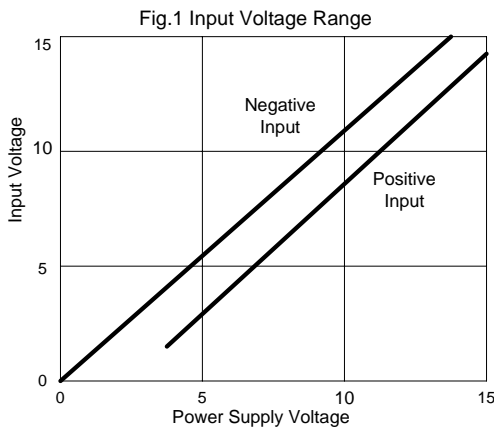

TYPICAL CHARACTERISTICS(Cont.)

Fig. 7 Voltage Follower Pulse Response

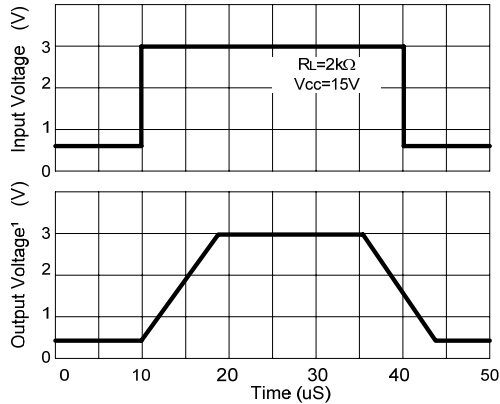

Fig. 8 Voltage Follower Response (Small Signal)

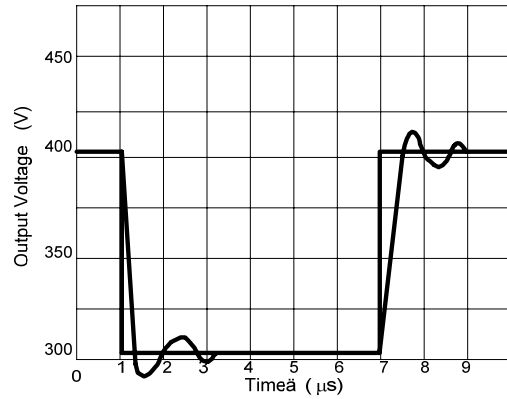

Fig. 9 Gain vs Large Signal Frequency

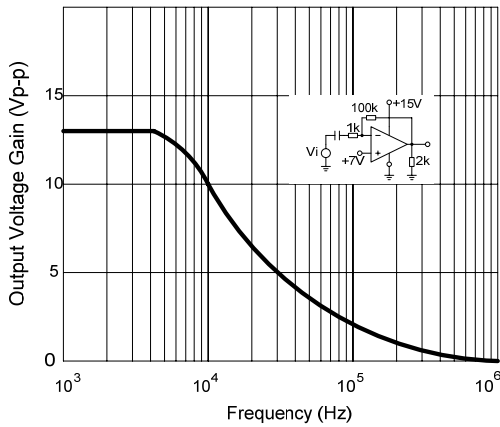

Fig. 10 Output Current Sinking vs Output Voltage

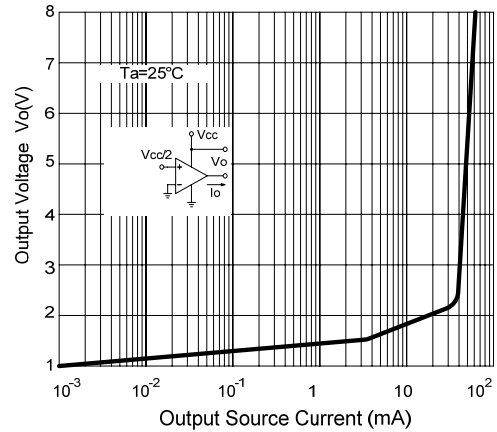

Fig. 11 Output Sink Current vs Output Voltage

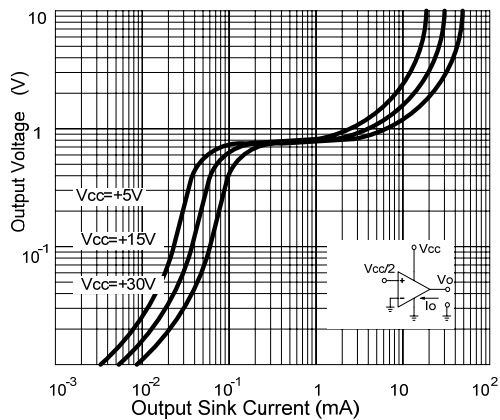
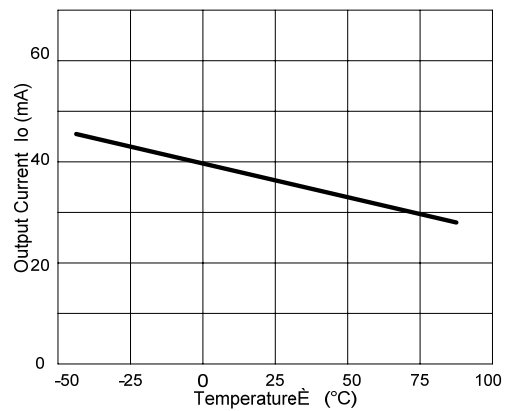

Fig. 12 Current Limiting vs Temperature



UTC assumes no responsibility for equipment failures that result from using products at values that exceed, even momentarily, rated values (such as maximum ratings, operating condition ranges, or other parameters) listed in products specifications of any and all UTC products described or contained herein. UTC products are not designed for use in life support appliances, devices or systems where malfunction of these products can be reasonably expected to result in personal injury. Reproduction in whole or in part is prohibited without the prior written consent of the copyright owner. The information presented in this document does not form part of any quotation or contract, is believed to be accurate and reliable and may be changed without notice.

