



0.7Ω, Low-Voltage, Quad 2:1 Analog Multiplexers

MAX4780/MAX4784

General Description

The MAX4780/MAX4784 are low on-resistance, low-voltage, quad 2:1 analog multiplexers that operate from a single +1.6V to +4.2V supply. These devices have fast switching speeds ($t_{ON} = 20ns$, $t_{OFF} = 8ns$), handle rail-to-rail analog signals, and consume less than 1μW of quiescent power.

When powered from a +2.7V supply, the MAX4780/MAX4784 feature low 0.7Ω on-resistance (R_{ON}), and 0.1Ω R_{ON} flatness. The digital logic input is +1.8V CMOS-logic compatible when using a single +3V supply.

The MAX4780/MAX4784 are available in 16-pin TSSOP and 3mm x 3mm thin QFN packages.

Applications

- Power Routing
- Battery-Powered Systems
- Audio and Video Signal Routing
- Low-Voltage Data-Acquisition Systems
- Communications Circuits
- PCMCIA Cards
- Cellular Phones
- Modems
- Hard Drives

Features

- ◆ Single-Supply Operation from 1.6V to 4.2V
- ◆ Low R_{ON}
 - 0.7Ω (+2.7V Supply)
 - 2Ω (+1.8V Supply)
- ◆ 0.1Ω R_{ON} Flatness (+2.7V Supply)
- ◆ 3mm x 3mm Thin QFN Package
- ◆ +1.8V CMOS Logic Compatible
- ◆ Fast Switching: $t_{ON} = 20ns$, $t_{OFF} = 8ns$

Ordering Information

PART	TEMP RANGE	PIN-PACKAGE
MAX4780ETE	-40°C to +85°C	16 Thin QFN-EP*
MAX4780EUE	-40°C to +85°C	16 TSSOP
MAX4784ETE	-40°C to +85°C	16 Thin QFN-EP*
MAX4784EUE	-40°C to +85°C	16 TSSOP

*EP = Exposed pad.

Pin Configurations/Functional Diagrams/Truth Tables

TOP VIEW

THIN QFN-EP

MAX4780	
A0	ON SWITCH
0	NC1, NC2
1	NO1, NO2
A1	ON SWITCH
0	NC3, NC4
1	NO3, NO4

MAX4784		
EN	A0	ON SWITCH
1	X	NONE
0	0	COM1-NC1 COM2-NC2 COM3-NC3 COM4-NC4
0	1	COM1-NO1 COM2-NO2 COM3-NO3 COM4-NO4

THIN QFN-EP

Pin Configurations/Functional Diagrams/Truth Tables continued at end of data sheet.



For pricing, delivery, and ordering information, please contact Maxim Direct at 1-888-629-4642, or visit Maxim's website at www.maxim-ic.com.

0.7 Ω , Low-Voltage, Quad 2:1 Analog Multiplexers

ABSOLUTE MAXIMUM RATINGS

Voltages Referenced to GND

V+, A_, \overline{EN}	-0.3V to +4.6V
COM_, NO_, NC_ (Note 1)	-0.3V to (V+ + 0.3V)
Continuous Current COM_, NO_, NC_	\pm 300mA
Peak Current COM_, NO_, NC_ (pulsed at 1ms 10% duty cycle)	\pm 500mA

Continuous Power Dissipation ($T_A = +70^\circ\text{C}$)

16-Pin Thin QFN (derate 14.7mW/ $^\circ\text{C}$ above $+70^\circ\text{C}$)	1176.5mW
16-Pin TSSOP (derate 9.4mW/ $^\circ\text{C}$ above $+70^\circ\text{C}$)	755mW
Operating Temperature Range	-40°C to $+85^\circ\text{C}$
Maximum Junction Temperature	$+150^\circ\text{C}$
Storage Temperature Range	-65°C to $+150^\circ\text{C}$
Lead Temperature (soldering, 10s)	$+300^\circ\text{C}$

Note 1: Signals on COM_, NO_, or NC_ exceeding V+ or GND are clamped by internal diodes. Limit forward current to maximum current rating.

Stresses beyond those listed under "Absolute Maximum Ratings" may cause permanent damage to the device. These are stress ratings only, and functional operation of the device at these or any other conditions beyond those indicated in the operational sections of the specifications is not implied. Exposure to absolute maximum rating conditions for extended periods may affect device reliability.

ELECTRICAL CHARACTERISTICS—Single +3V Supply

(V+ = +2.7V to +4.2V, $V_{IH} = +1.4\text{V}$, $V_{IL} = +0.5\text{V}$, $T_A = T_{MIN}$ to T_{MAX} , unless otherwise specified. Typical values are at V+ = +3.0V, $T_A = +25^\circ\text{C}$.) (Notes 2, 3)

PARAMETER	SYMBOL	CONDITIONS	T_A	MIN	TYP	MAX	UNITS
ANALOG SWITCH							
Analog Signal Range	$V_{COM_}$, $V_{NO_}$, $V_{NC_}$			0		V+	V
On-Resistance (Note 4)	R_{ON}	V+ = 2.7V, $I_{COM_} = 100\text{mA}$, $V_{NO_}$ or $V_{NC_} = 1.5\text{V}$	$+25^\circ\text{C}$	0.7		1	Ω
			T_{MIN} to T_{MAX}			1.2	
On-Resistance Match Between Channels (Notes 4, 5)	ΔR_{ON}	V+ = 2.7V, $I_{COM_} = 100\text{mA}$, $V_{NO_}$ or $V_{NC_} = 1.5\text{V}$	$+25^\circ\text{C}$	0.1		0.15	Ω
			T_{MIN} to T_{MAX}			0.2	
On-Resistance Flatness (Note 6)	$R_{FLAT(ON)}$	V+ = 2.7V, $I_{COM_} = 100\text{mA}$; $V_{NO_}$ or $V_{NC_} = 1\text{V}, 1.5\text{V}, 2\text{V}$	$+25^\circ\text{C}$	0.1		0.2	Ω
			T_{MIN} to T_{MAX}			0.3	
NO_ or NC_ Off-Leakage Current (Note 7)	$I_{NO_(OFF)}$, $I_{NC_(OFF)}$	V+ = 3.6V; $V_{COM_} = 0.3\text{V}, 3.3\text{V}$; $V_{NO_}$ or $V_{NC_} = 3.3\text{V}, 0.3\text{V}$	$+25^\circ\text{C}$	-1	± 0.002	+1	nA
			T_{MIN} to T_{MAX}	-5		+5	
COM_ Off-Leakage Current (MAX4784 Only) (Note 7)	$I_{COM_(OFF)}$	V+ = 3.6V; $V_{COM_} = 0.3\text{V}, 3.3\text{V}$; $V_{NO_}$ or $V_{NC_} = 3.3\text{V}, 0.3\text{V}$, or unconnected	$+25^\circ\text{C}$	-1	± 0.002	+1	nA
			T_{MIN} to T_{MAX}	-5		+5	
COM_ On-Leakage Current (Note 7)	$I_{COM_(ON)}$	V+ = 3.6V; $V_{COM_} = 3.3\text{V}, 0.3\text{V}$; $V_{NO_}$ or $V_{NC_} = 3.3\text{V}, 0.3\text{V}$, or unconnected	$+25^\circ\text{C}$	-2	± 0.002	+2	nA
			T_{MIN} to T_{MAX}	-10		+10	

0.7Ω, Low-Voltage, Quad 2:1 Analog Multiplexers

MAX4780/MAX4784

ELECTRICAL CHARACTERISTICS—Single +3V Supply (continued)

(V+ = +2.7V to +4.2V, V_{IH} = +1.4V, V_{IL} = +0.5V, T_A = T_{MIN} to T_{MAX}, unless otherwise specified. Typical values are at V+ = +3.0V, T_A = +25°C.) (Notes 2, 3)

PARAMETER	SYMBOL	CONDITIONS	T _A	MIN	TYP	MAX	UNITS
SWITCH DYNAMIC CHARACTERISTICS							
Turn-On Time	t _{ON}	V _{NO_} , V _{NC_} = 1.5V, R _L = 50Ω, C _L = 35pF, Figure 1	+25°C	20	25	ns	
			T _{MIN} to T _{MAX}	30			
Turn-Off Time	t _{OFF}	V _{NO_} , V _{NC_} = 1.5V, R _L = 50Ω, C _L = 35pF, Figure 1	+25°C	8	10	ns	
			T _{MIN} to T _{MAX}	18			
Break-Before-Make (Note 8)	t _{BBM}	V _{NO_} , V _{NC_} = 1.5V, R _L = 50Ω, C _L = 35pF, Figure 2	+25°C	7		ns	
			T _{MIN} to T _{MAX}	1			
Charge Injection	Q	V _{GEN} = 0, R _{GEN} = 0, C _L = 1.0nF, Figure 3	+25°C	5		pC	
NO_ or NC_ Off-Capacitance	C _{OFF}	f = 1MHz, Figure 4	+25°C	33		pF	
COM_ Off-Capacitance	C _{COM_(OFF)}	f = 1MHz, Figure 4	+25°C	60		pF	
COM_ On-Capacitance	C _{COM_(ON)}	f = 1MHz, Figure 4	+25°C	85		pF	
-3dB On-Channel Bandwidth	BW	Signal = 0, R _{IN} = R _{OUT} = 50Ω, C _L = 5pF, Figure 5		123		MHz	
Off-Isolation (Note 9)	V _{ISO}	f = 1MHz, V _{COM_} = 1V _{P-P} , R _L = 50Ω, C _L = 5pF, Figure 5	+25°C	-67		dB	
Crosstalk (Note 10)	V _{CT}	f = 1MHz, V _{COM_} = 1V _{P-P} , R _L = 50Ω, C _L = 5pF, Figures 4, 5	+25°C	-95		dB	
Total Harmonic Distortion	THD	f = 20Hz to 20kHz, V _{COM_} = 2V _{P-P} , R _L = 32Ω	+25°C	0.008		%	
LOGIC INPUT (A_, \overline{EN})							
Input Logic-High	V _{IH}			1.8		V	
Input Logic-Low	V _{IL}			0.5		V	
Input Leakage Current	I _{IN}	V \overline{EN} = 0 or +3.6V, V _{A0} = 0 or +3.6V		-1	0.005	+1	μA
POWER SUPPLY							
Power-Supply Range	V+			1.6	3.6		V
Positive Supply Current	I+	V+ = 3.6V, \overline{EN} , A0 = 0 or V+, all channels on or off	T _{MIN} to T _{MAX}	2		μA	

0.7Ω, Low-Voltage, Quad 2:1 Analog Multiplexers

ELECTRICAL CHARACTERISTICS—Single +1.8V Supply

($V_+ = +1.8V$, $V_{IH} = +1.0V$, $V_{IL} = +0.4V$, $T_A = T_{MIN}$ to T_{MAX} , unless otherwise specified. Typical values are at $T_A = +25^\circ C$.) (Notes 2, 3)

PARAMETER	SYMBOL	CONDITIONS	T_A	MIN	TYP	MAX	UNITS
ANALOG SWITCH							
Analog Signal Range	$V_{COM_}$, $V_{NO_}$, $V_{NC_}$			0		V_+	V
On-Resistance	R_{ON}	$I_{COM_} = 10mA$, $V_{NO_}$ or $V_{NC_} = 1.0V$	+25°C	2	3		Ω
			T_{MIN} to T_{MAX}			5	
NO_ or NC_ Off-Leakage Current (Note 7)	$I_{NO_ (OFF)}$, $I_{NC_ (OFF)}$	$V_{COM_} = 0.3V, 1.5V$; $V_{NO_}$ or $V_{NC_} = 1.5V$, 0.3V	+25°C	-1		+1	nA
			T_{MIN} to T_{MAX}	-5		+5	
COM_ Off-Leakage Current (MAX4784 Only) (Note 7)	$I_{COM_ (OFF)}$	$V_{COM_} = 0.3V, 1.5V$; $V_{NO_}$ or $V_{NC_} = 1.5V$, 0.3V	+25°C	-1		+1	nA
			T_{MIN} to T_{MAX}	-5		+5	
COM_ On-Leakage Current (Note 7)	$I_{COM_ (ON)}$	$V_{COM_} = 0.3V, 1.5V$; $V_{NO_}$ or $V_{NC_} = 0.3V$, 1.5V, or unconnected	+25°C	-2		+2	nA
			T_{MIN} to T_{MAX}	-10		+10	
SWITCH DYNAMIC CHARACTERISTICS							
Turn-On Time	t_{ON}	$V_{NO_}, V_{NC_} = 1.0V$, $R_L = 50\Omega$, $C_L = 35pF$, Figure 1	+25°C	25	30		ns
			T_{MIN} to T_{MAX}			35	
Turn-Off Time	t_{OFF}	$V_{NO_}, V_{NC_} = 1.0V$, $R_L = 50\Omega$, $C_L = 35pF$, Figure 1	+25°C	10	15		ns
			T_{MIN} to T_{MAX}			20	
Break-Before-Make (Note 8)	t_{BBM}	$V_{NO_}, V_{NC_} = 1.0V$, $R_L = 50\Omega$, $C_L = 35pF$, Figure 2	+25°C	10			ns
			T_{MIN} to T_{MAX}	1			
Charge Injection	Q	$V_{GEN} = 0$, $R_{GEN} = 0$, $C_L = 1nF$, Figure 3	+25°C		5		pC

0.7Ω, Low-Voltage, Quad 2:1 Analog Multiplexers

MAX4780/MAX4784

ELECTRICAL CHARACTERISTICS—Single +1.8V Supply (continued)

($V_+ = +1.8V$, $V_{IH} = +1.0V$, $V_{IL} = +0.4V$, $T_A = T_{MIN}$ to T_{MAX} , unless otherwise specified. Typical values are at $T_A = +25^\circ C$.) (Notes 2, 3)

PARAMETER	SYMBOL	CONDITIONS	T_A	MIN	TYP	MAX	UNITS
LOGIC INPUT (A_+, \overline{EN})							
Input Logic-High	V_{IH}			1.8			V
Input Logic-Low	V_{IL}					0.4	V
Input Leakage Current	I_{IN}	$V_{\overline{EN}} = 0$ or $+3.6V$, $V_{A0} = 0$ or $+3.6V$		-1		+1	μA

Note 2: The algebraic convention, where the most negative value is a minimum and the most positive value is a maximum, is used in this data sheet.

Note 3: $-40^\circ C$ specifications are guaranteed by design.

Note 4: R_{ON} and ΔR_{ON} matching specifications for QFN packaged parts are guaranteed by design.

Note 5: $\Delta R_{ON} = R_{ON(MAX)} - R_{ON(MIN)}$.

Note 6: Flatness is defined as the difference between the maximum and the minimum value of on-resistance as measured over the specified analog signal ranges.

Note 7: Leakage parameters are 100% tested at $T_A = +85^\circ C$, and guaranteed by correlation over the full rated temperature range.

Note 8: Guaranteed by design.

Note 9: Off-isolation = $20 \log_{10}(V_{COM_}/V_{NO_})$. $V_{COM_}$ = output, $V_{NO_}$ = input to off switch.

Note 10: Between two switches.

Note 11: Parts are guaranteed to 1 million cycles of operation. (Cycle = switch on \rightarrow switch off \rightarrow switch on.)

Note 12: The minimum load resistance is 8Ω . (See the *Typical Application Circuit*.)

Typical Operating Characteristics

($T_A = +25^\circ C$, unless otherwise noted.)

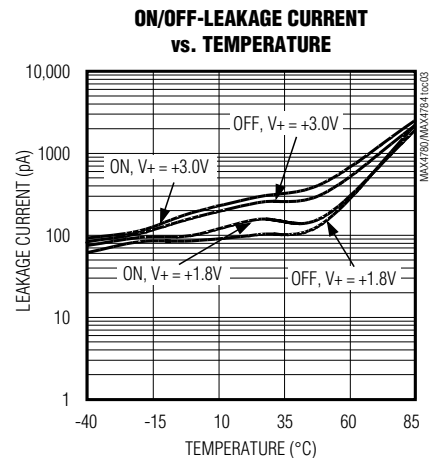
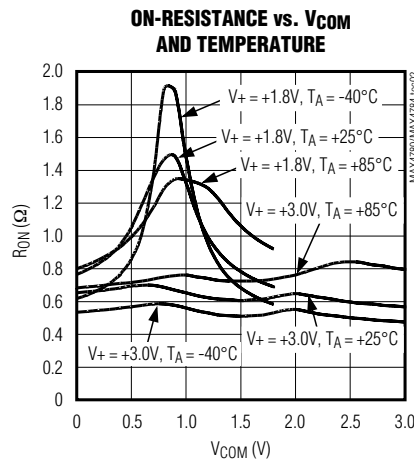
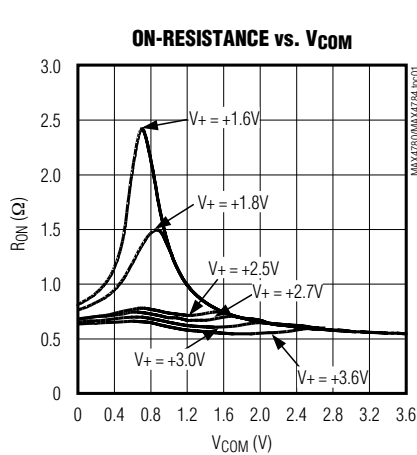

0.7Ω, Low-Voltage, Quad 2:1 Analog Multiplexers

Typical Operating Characteristics (continued)

(T_A = +25°C, unless otherwise noted.)

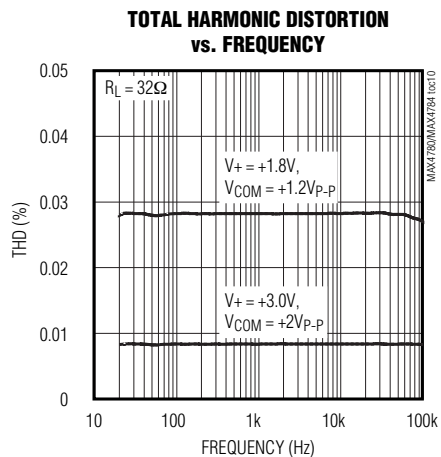
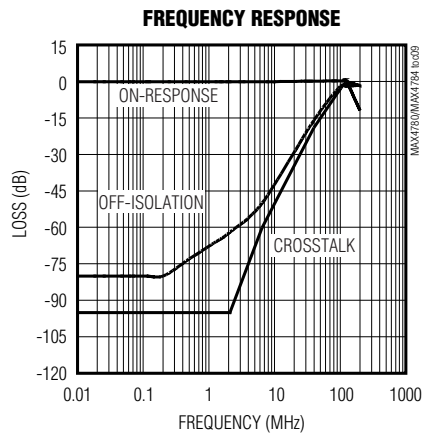
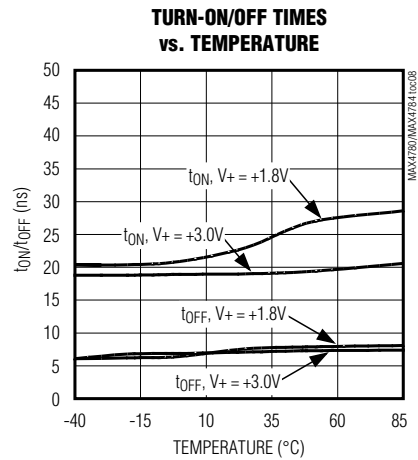
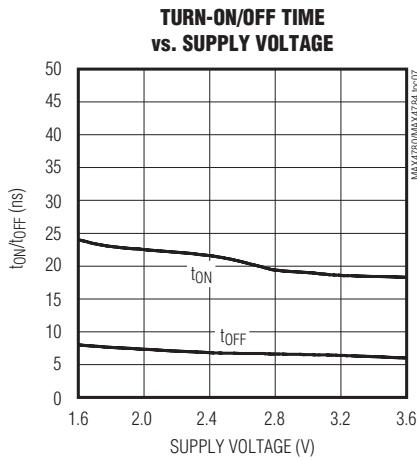
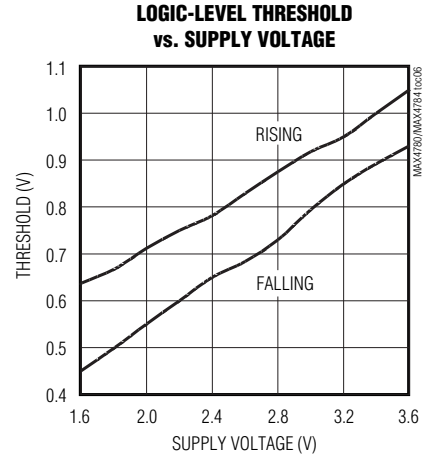
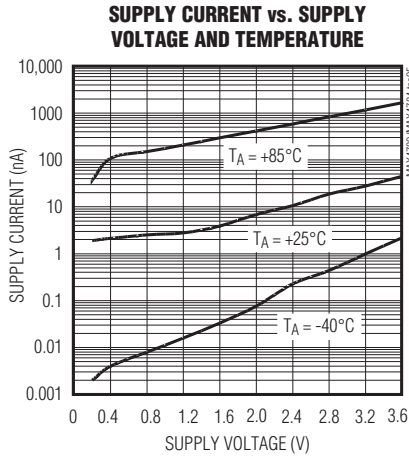
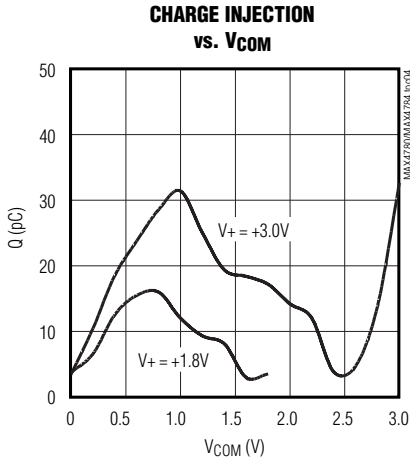

0.7Ω, Low-Voltage, Quad 2:1 Analog Multiplexers

Pin Description

MAX4780/MAX4784

PIN				NAME	FUNCTION
MAX4780		MAX4784			
TSSOP	THIN QFN-EP	TSSOP	THIN QFN-EP		
1	15	1	15	A0	Address Input
2	16	2	16	NC1	Normally Closed Terminal
3	1	3	1	NO1	Normally Open Terminal
4	2	4	2	COM1	Analog Switch Common Terminal
5	3	5	3	NC2	Normally Closed Terminal
6	4	6	4	NO2	Normally Open Terminal
7	5	7	5	COM2	Analog Switch Common Terminal
8	6	8	6	GND	Ground
9	7	9	7	COM3	Analog Switch Common Terminal
10	8	10	8	NO3	Normally Open Terminal
11	9	11	9	NC3	Normally Closed Terminal
12	10	12	10	COM4	Analog Switch Common Terminal
13	11	13	11	NO4	Normally Open Terminal
14	12	14	12	NC4	Normally Closed Terminal
15	13	—	—	A1	Address Input
—	—	15	13	$\overline{\text{EN}}$	Enable. Connect to GND for normal operation. Connect to logic-level high to turn all switches off.
16	14	16	14	V+	Positive Supply Voltage
—	—	—	—	EP	Exposed Pad. Internally connected to GND. Connect to a large ground plane to maximize thermal performance. Not intended as an electrical connection point. (Thin QFN package only.)

Detailed Description

The MAX4780/MAX4784 are low 0.7Ω (at V+ = +2.7V) on-resistance, low-voltage, quad 2:1 analog multiplexers/demultiplexers that operate from a +1.6V to +4.2V single supply. CMOS switch construction allows switching analog signals that are within the supply voltage range (GND to V+).

When powered from a +2.7V supply, the 0.7Ω R_{ON} allows high continuous currents to be switched in a variety of applications.

Applications Information

Proper power-supply sequencing is recommended for all CMOS devices. Do not exceed the absolute maximum ratings, because stresses beyond the listed ratings can cause permanent damage to the devices. Always sequence V+ on first, followed by NO_, NC_, or COM_.

Although it is not required, power-supply bypassing improves noise margin and prevents switching noise propagation from the V+ supply to other components. A 0.1μF capacitor, connected from V+ to GND, is adequate for most applications.

Typical Application Circuit

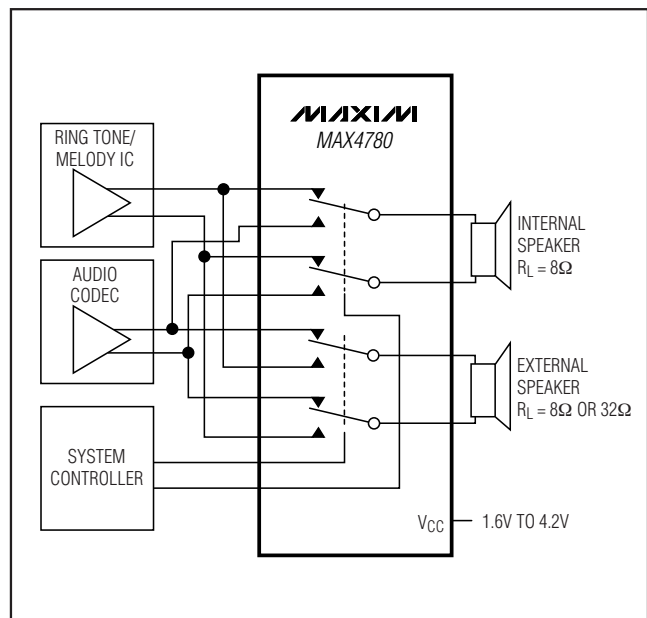

0.7Ω, Low-Voltage, Quad 2:1 Analog Multiplexers

Logic Inputs

The MAX4780/MAX4784 logic inputs can be driven up to +4.2V regardless of the supply voltage. For example, with a +1.8V supply, A₋ and EN̄ may be driven low to GND and high to +4.2V. Driving A₋ and EN̄ rail-to-rail minimizes power consumption. Drive EN̄ low to enable the COM₋ outputs. When EN̄ is high, the COM₋ outputs are high impedance.

Analog Signal Levels

Analog signals that range over the entire supply voltage (V₊ to GND) can be passed with very little change in on-

resistance (see the *Typical Operating Characteristics*). The switches are bidirectional, so the NO₋, NC₋, and COM₋ pins can be used as either inputs or outputs.

Layout

High-speed switches require proper layout and design procedures for optimum performance. Reduce stray inductance and capacitance by keeping traces short and wide. Ensure that bypass capacitors are as close to the device as possible. Use large ground planes where possible.

Test Circuits/Timing Diagrams

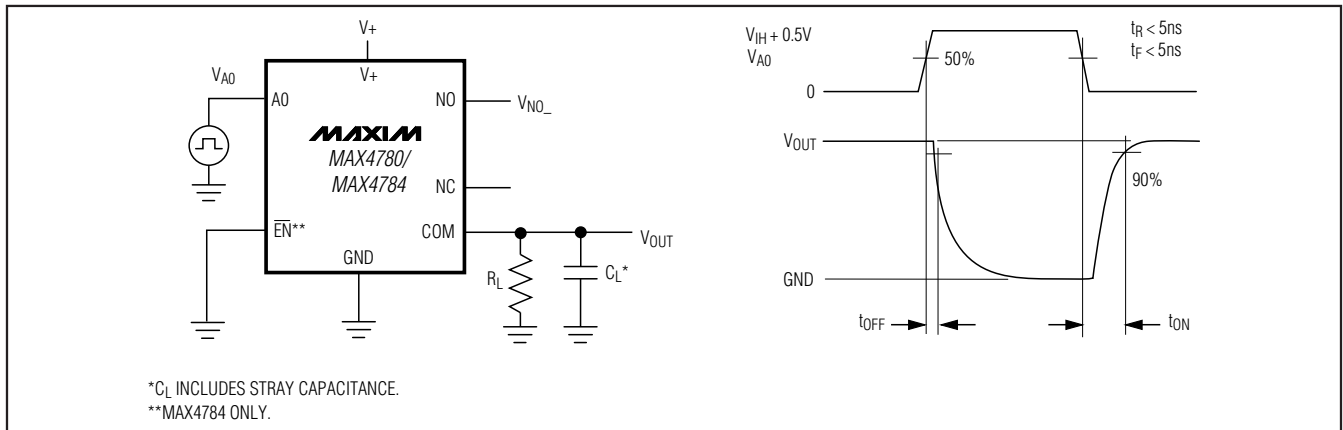

Figure 1. Turn-On and Turn-Off Times

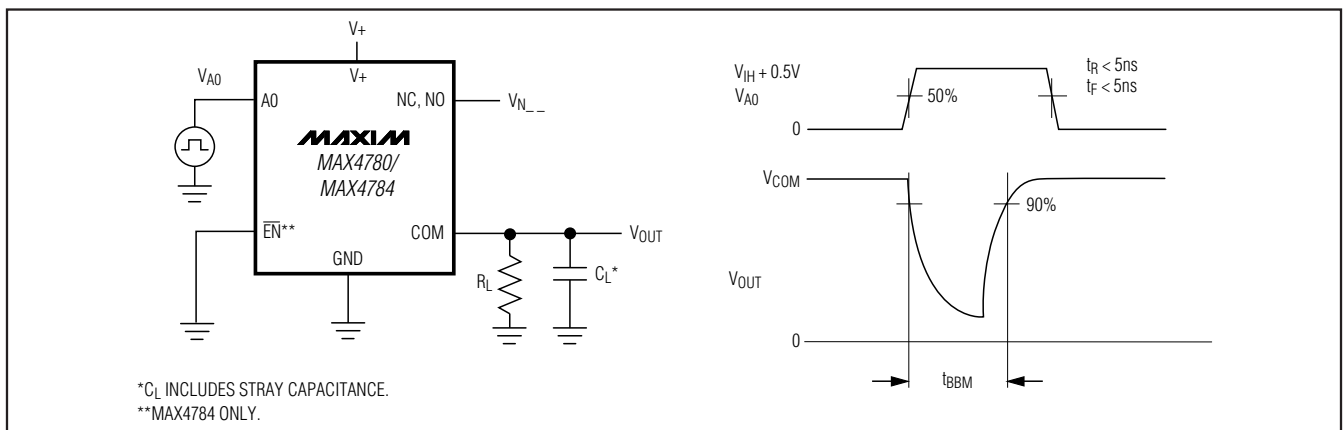

Figure 2. Break-Before-Make Interval

0.7Ω, Low-Voltage, Quad 2:1 Analog Multiplexers

Test Circuits/Timing Diagrams (continued)

MAX4780/MAX4784

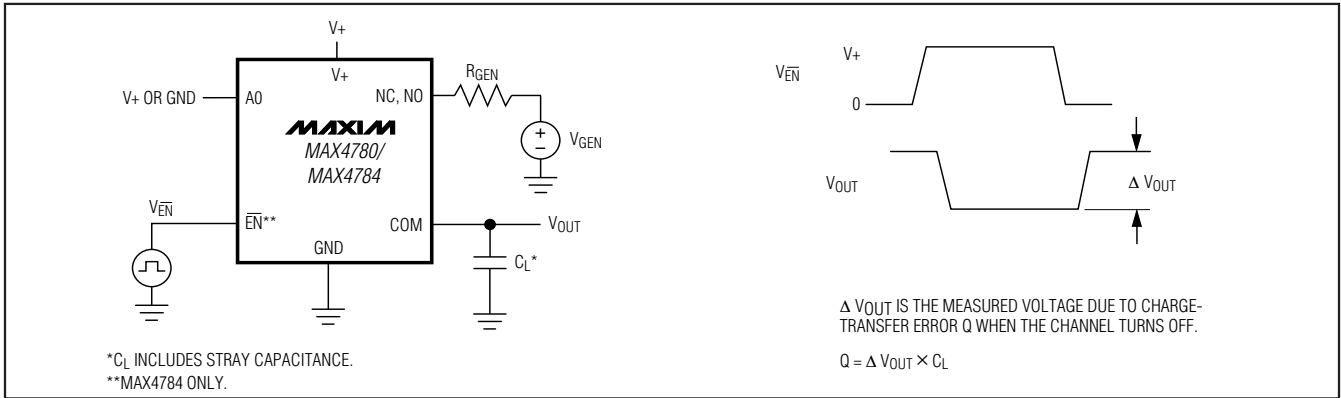

Figure 3. Charge Injection

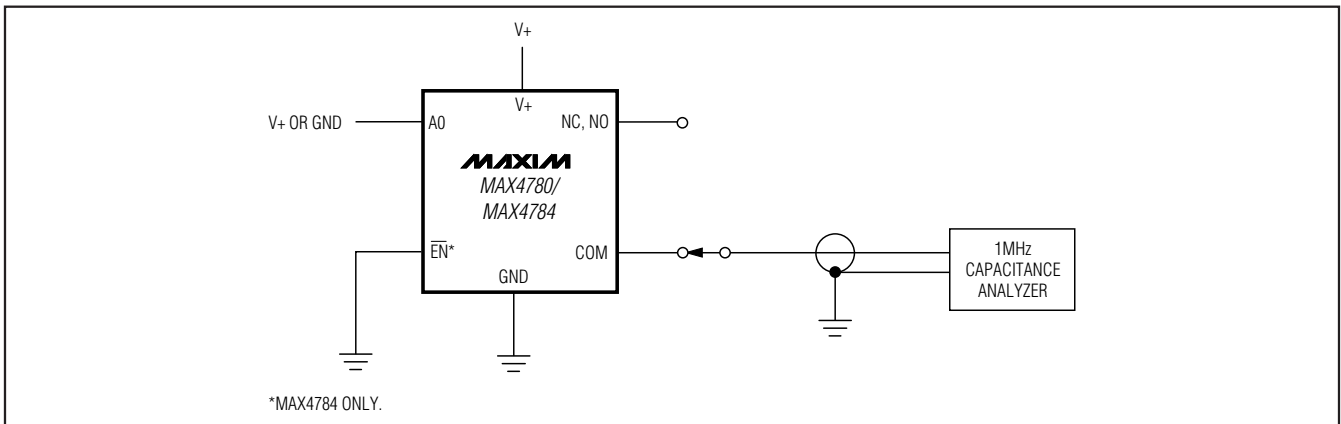

Figure 4. Capacitance

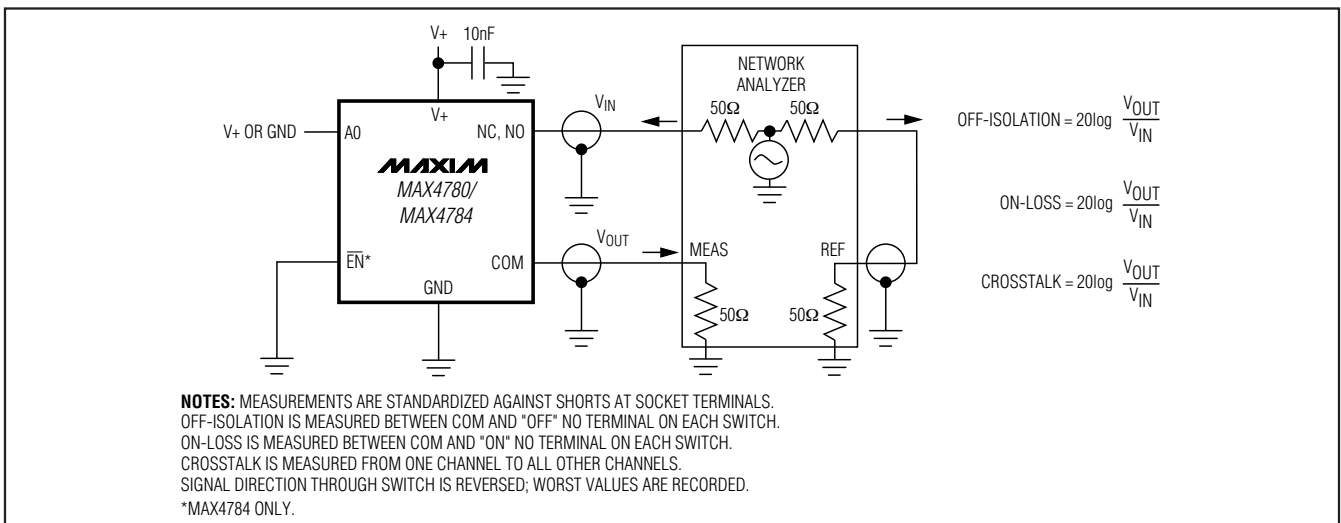
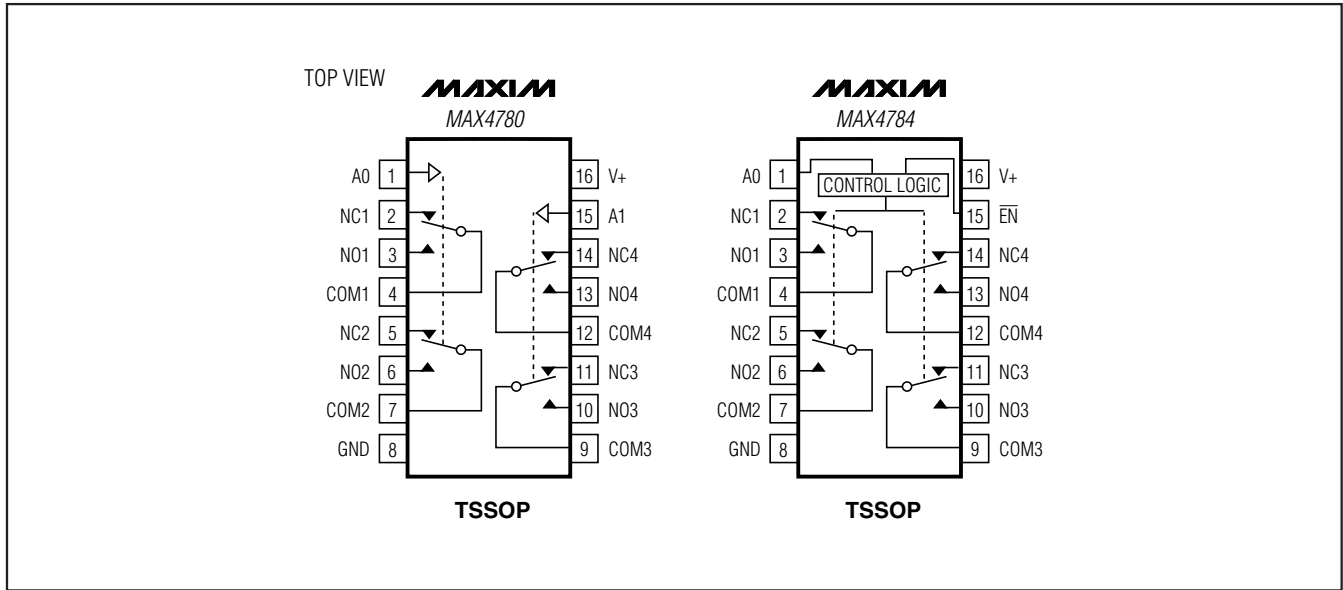

Figure 5. Off-Isolation, On-Loss, and Crosstalk

0.7Ω, Low-Voltage, Quad 2:1 Analog Multiplexers

Pin Configurations/Functional Diagrams/Truth Tables (continued)



Chip Information

PROCESS: CMOS

Package Information

For the latest package outline information and land patterns, go to www.maxim-ic.com/packages.

PACKAGE TYPE	PACKAGE CODE	DOCUMENT NO.
16 TQFN	T1633+4	21-0136
16 TSSOP	U16+2	21-0066

0.7Ω, Low-Voltage, Quad 2:1 Analog Multiplexers

Revision History

REVISION NUMBER	REVISION DATE	DESCRIPTION	PAGES CHANGED
0	4/02	Initial release	—
1	1/04	Added MAX4780	—
2	9/04	Changed Ab max voltage	—
3	12/04	Change operation to 4.2V	—
4	3/09	Added exposed pad information	1, 2, 4, 7, 10,

MAX4780/MAX4784

Maxim cannot assume responsibility for use of any circuitry other than circuitry entirely embodied in a Maxim product. No circuit patent licenses are implied. Maxim reserves the right to change the circuitry and specifications without notice at any time.

Maxim Integrated Products, 120 San Gabriel Drive, Sunnyvale, CA 94086 408-737-7600 _____ 11

© 2009 Maxim Integrated Products

Maxim is a registered trademark of Maxim Integrated Products, Inc.