

LM4675 Boomer® Audio Power Amplifier Series

Ultra-Low EMI, Filterless, 2.65W, Mono, Class D Audio Power Amplifier with Spread Spectrum

General Description

The LM4675 is a single supply, high efficiency, 2.65W, mono, Class D audio amplifier. A spread spectrum, filterless PWM architecture reduces EMI and eliminates the output filter, reducing external component count, board area consumption, system cost, and simplifying design.

The LM4675 is designed to meet the demands of mobile phones and other portable communication devices. Operating on a single 5V supply, it is capable of driving a 4Ω speaker load at a continuous average output of 2.2W with less than 1% THD+N. Its flexible power supply requirements allow operation from 2.4V to 5.5V. The wide band spread spectrum architecture of the LM4675 reduces EMI-radiated emissions due to the modulator frequency.

The LM4675 has high efficiency with speaker loads compared to a typical Class AB amplifier. With a 3.6V supply driving an 8Ω speaker, the IC's efficiency for a 100mW power level is 80%, reaching 89% at 400mW output power.

The LM4675 features a low-power consumption shutdown mode. Shutdown may be enabled by driving the Shutdown pin to a logic low (GND).

The gain of the LM4675 is externally configurable which allows independent gain control from multiple sources by summing the signals. Output short circuit and thermal overload protection prevent the device from damage during fault conditions.

Key Specifications

- Efficiency at 3.6V, 400mW into 8Ω speaker 89% (typ)
- Efficiency at 3.6V, 100mW into 8Ω speaker 80% (typ)
- Efficiency at 5V, 1W into 8Ω speaker 89% (typ)
- Quiescent current, 3.6V supply 2.2mA (typ)
- Total shutdown power supply current 0.01μA (typ)
- Single supply range 2.4V to 5.5V
- PSRR, f = 217Hz 82dB

Features

- Spread spectrum architecture reduces EMI
- Mono Class D Operation
- No output filter required for inductive loads
- Externally configurable gain
- Very fast turn on time: 17μs (typ)
- Minimum external components
- "Click and pop" suppression circuitry
- Micro-power shutdown mode
- Available in space-saving 0.5mm pitch micro SMD and LLP packages

Applications

- Mobile phones
- PDAs
- Portable electronic devices

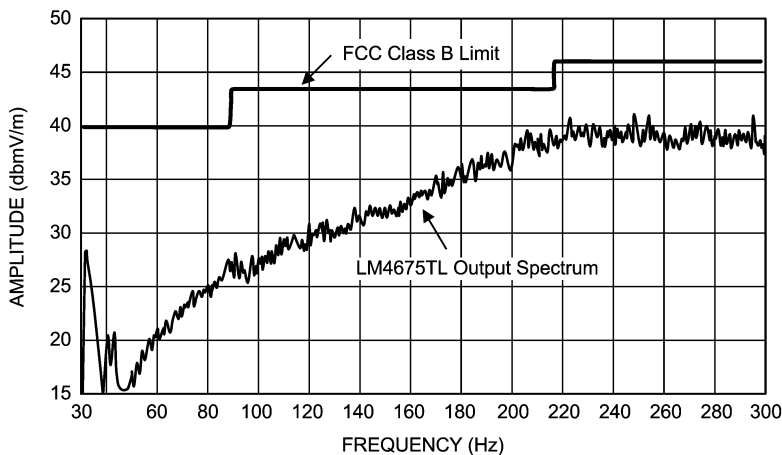

LM4675 Rf Emissions — 6in cable

20182721

Boomer® is a registered trademark of National Semiconductor Corporation.

Typical Application

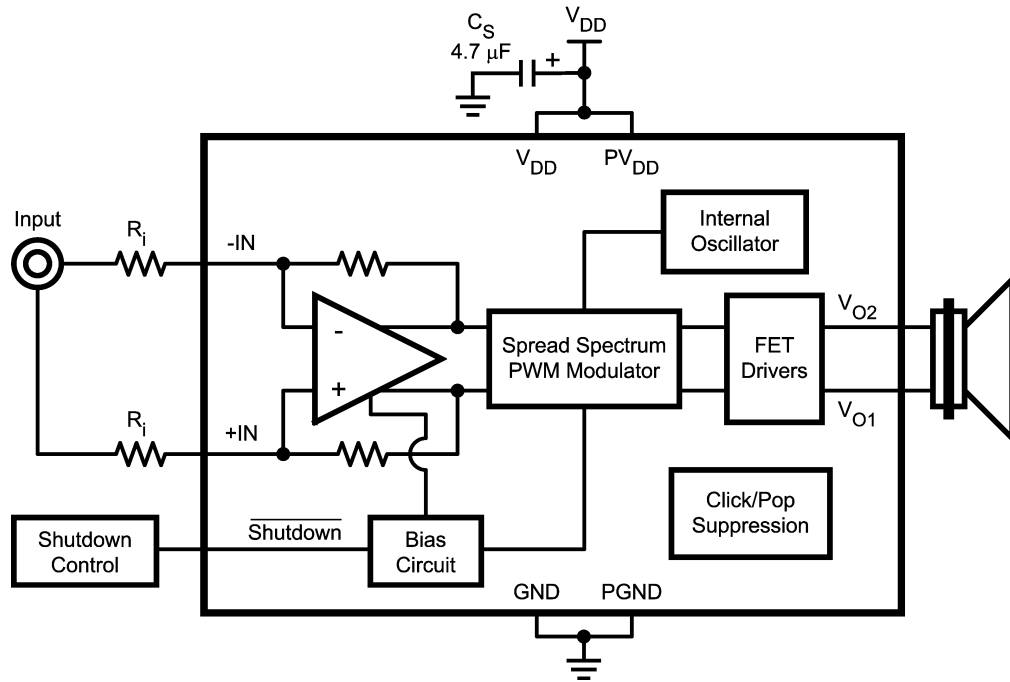

201827J3

FIGURE 1. Typical Audio Amplifier Application Circuit

Connection Diagrams

9 Bump micro SMD Package

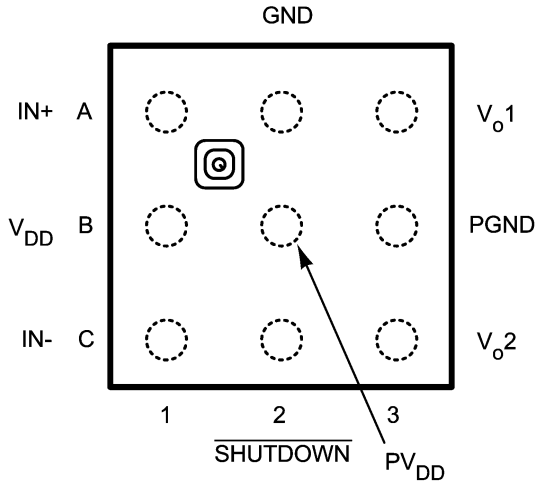

20182736

Top View
 Order Number LM4675TL
 See NS Package Number TBD

Leadless Leadframe Package (LLP)

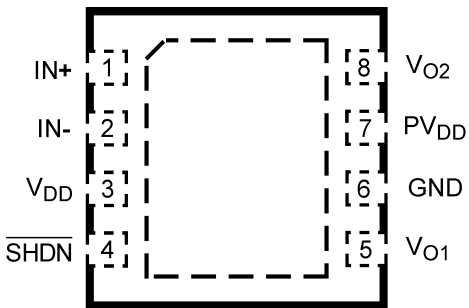

20182703

Top View
 Order Number LM4675SD
 See NS Package Number SDA08A
 Contact NSC Sales Office for Availability

micro SMD Marking

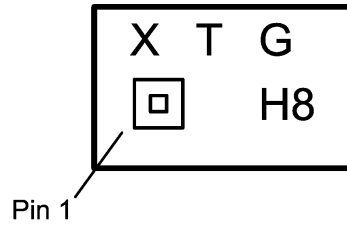

20182757

Top View
 X — Date Code
 T — Die Traceability
 G — Boomer Family
 H8 — LM4675TL

LLP Marking

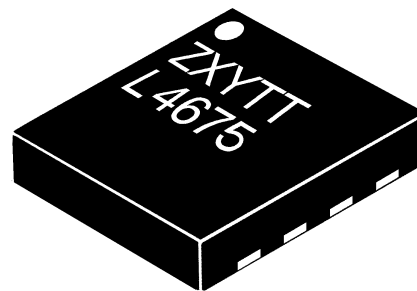

20182704

Top View
 Z — Plant Code
 XY — Date Code
 TT — Die Traceability
 L4675 — LM4675SD

Absolute Maximum Ratings (Notes 1, 2)

If Military/Aerospace specified devices are required, please contact the National Semiconductor Sales Office/Distributors for availability and specifications.

Supply Voltage (Note 1)	6.0V
Storage Temperature	-65°C to +150°C
Voltage at Any Input Pin	$V_{DD} + 0.3V \geq V \geq GND - 0.3V$
Power Dissipation (Note 3)	Internally Limited
ESD Susceptibility, all other pins (Note 4)	2.0kV
ESD Susceptibility (Note 5)	200V
Junction Temperature (T_{JMAX})	150°C
Thermal Resistance	

 θ_{JA} (micro SMD) 220°C/W

 θ_{JA} (LLP) 73°C/W

Soldering Information

See AN-1112 "microSMD Wafers Level Chip Scale Package."

Operating Ratings (Note 1) (Note 2)

Temperature Range

 $T_{MIN} \leq T_A \leq T_{MAX}$ -40°C ≤ T_A ≤ 85°C

Supply Voltage

 $2.4V \leq V_{DD} \leq 5.5V$
Electrical Characteristics (Notes 1, 2)

The following specifications apply for $A_V = 2V/V$ ($R_L = 150k\Omega$), $R_L = 15\mu H + 8\Omega + 15\mu H$ unless otherwise specified. Limits apply for $T_A = 25^\circ C$.

Symbol	Parameter	Conditions	LM4675		Units (Limits)
			Typical	Limit	
			(Note 6)	(Notes 7, 8)	
$ V_{OS} $	Differential Output Offset Voltage	$V_I = 0V, A_V = 2V/V,$ $V_{DD} = 2.4V$ to 5.0V	3		mV
$ I_{IH} $	Logic High Input Current	$V_{DD} = 5.0V, V_I = 5.5V$	17	100	μA (max)
$ I_{IL} $	Logic Low Input Current	$V_{DD} = 5.0V, V_I = -0.3V$	0.9	5	μA (max)
I_{DD}	Quiescent Power Supply Current	$V_{IN} = 0V, \text{No Load}, V_{DD} = 5.0V$	2.8	3.9	mA (max)
		$V_{IN} = 0V, \text{No Load}, V_{DD} = 3.6V$	2.2	2.9	mA
		$V_{IN} = 0V, \text{No Load}, V_{DD} = 2.4V$	1.6	2.3	mA (max)
		$V_{IN} = 0V, R_L = 8\Omega, V_{DD} = 5.0V$	2.8		
		$V_{IN} = 0V, R_L = 8\Omega, V_{DD} = 3.6V$	2.2		
		$V_{IN} = 0V, R_L = 8\Omega, V_{DD} = 2.4V$	1.6		
I_{SD}	Shutdown Current	$V_{SHUTDOWN} = 0V$ $V_{DD} = 2.4V$ to 5.0V	0.01	1.0	μA (max)
V_{SDIH}	Shutdown voltage input high			1.4	V (min)
V_{SDIL}	Shutdown voltage input low			0.4	V (max)
R_{OSD}	Output Impedance	$V_{SHUTDOWN} = 0.4V$	100		k Ω
A_V	Gain		300k Ω/R_L		V/V (min) V/V (max)
R_{SD}	Resistance from Shutdown Pin to GND		300		k Ω
P_O	Output Power	$R_L = 15\mu H + 4\Omega + 15\mu H$ THD = 10% (max) $f = 1kHz, 22kHz$ BW $V_{DD} = 5V$	2.7		W
		$V_{DD} = 3.6V$	1.3		W
		$V_{DD} = 2.5V$	560		mW
		$R_L = 15\mu H + 4\Omega + 15\mu H$ THD = 1% (max) $f = 1kHz, 22kHz$ BW $V_{DD} = 5V$	2.2		W
		$V_{DD} = 3.6V$	1.08		W
		$V_{DD} = 2.5V$	450		mW

Electrical Characteristics (Notes 1, 2)

The following specifications apply for $A_V = 2V/V$ ($R_I = 150k\Omega$), $R_L = 15\mu H + 8\Omega + 15\mu H$ unless otherwise specified. Limits apply for $T_A = 25^\circ C$. (Continued)

Symbol	Parameter	Conditions	LM4675		Units (Limits)
			Typical	Limit	
			(Note 6)	(Notes 7, 8)	
P_O	Output Power	$R_L = 15\mu H + 8\Omega + 15\mu H$ THD = 10% (max) $f = 1kHz, 22kHz$ BW			
		$V_{DD} = 5V$	1.6		W
		$V_{DD} = 3.6V$	820		mW
		$V_{DD} = 2.5V$	350		mW
		$R_L = 15\mu H + 8\Omega + 15\mu H$ THD = 1% (max) $f = 1kHz, 22kHz$ BW			
		$V_{DD} = 5V$	1.3		W
		$V_{DD} = 3.6V$	650	600	mW
		$V_{DD} = 2.5V$	290		mW
THD+N	Total Harmonic Distortion + Noise	$V_{DD} = 5V, P_O = 0.1W, f = 1kHz$	0.03		%
		$V_{DD} = 3.6V, P_O = 0.1W, f = 1kHz$	0.02		%
		$V_{DD} = 2.5V, P_O = 0.1W, f = 1kHz$	0.04		%
PSRR	Power Supply Rejection Ratio (Input Referred)	$V_{Ripple} = 200mV_{PP}$ Sine, $f_{Ripple} = 217Hz, V_{DD} = 3.6, 5V$ Inputs to AC GND, $C_1 = 2\mu F$	82		dB
		$V_{Ripple} = 200mV_{PP}$ Sine, $f_{Ripple} = 1kHz, V_{DD} = 3.6, 5V$ Inputs to AC GND, $C_1 = 2\mu F$	80		dB
SNR	Signal to Noise Ratio	$V_{DD} = 5V, P_O = 1W_{RMS}$	97		dB
ϵ_{OUT}	Output Noise (Input Referred)	$V_{DD} = 3.6V, f = 20Hz - 20kHz$ Inputs to AC GND, $C_1 = 2\mu F$ No Weighting	28		μV_{RMS}
		$V_{DD} = 3.6V, \text{Inputs to AC GND}$ $C_1 = 2\mu F, A$ Weighted	22		μV_{RMS}
CMRR	Common Mode Rejection Ratio (Input Referred)	$V_{DD} = 3.6V, V_{Ripple} = 1V_{PP}$ Sine $f_{Ripple} = 217Hz$	80		dB
T_{WU}	Wake-up Time	$V_{DD} = 3.6V$	17		μs
T_{SD}	Shutdown Time		140		μs
η	Efficiency	$V_{DD} = 3.6V, P_{OUT} = 400mW$ $R_L = 8\Omega$	89		%
		$V_{DD} = 5V, P_{OUT} = 1W$ $R_L = 8\Omega$	89		%

Note 1: All voltages are measured with respect to the ground pin, unless otherwise specified.

Note 2: *Absolute Maximum Ratings* indicate limits beyond which damage to the device may occur. *Operating Ratings* indicate conditions for which the device is functional, but do not guarantee specific performance limits. *Electrical Characteristics* state DC and AC electrical specifications under particular test conditions which guarantee specific performance limits. This assumes that the device is within the Operating Ratings. Specifications are not guaranteed for parameters where no limit is given, however, the typical value is a good indication of device performance.

Note 3: The maximum power dissipation must be derated at elevated temperatures and is dictated by T_{JMAX} , θ_{JA} , and the ambient temperature T_A . The maximum allowable power dissipation is $P_{DMAX} = (T_{JMAX} - T_A) / \theta_{JA}$ or the number given in Absolute Maximum Ratings, whichever is lower. For the LM4675, $T_{JMAX} = 150^\circ\text{C}$. The typical θ_{JA} is 99.1°C/W for the micro SMD package.

Note 4: Human body model, 100pF discharged through a $1.5\text{k}\Omega$ resistor.

Note 5: Machine Model, 220pF – 240pF discharged through all pins.

Note 6: Typical specifications are specified at 25°C and represent the parametric norm.

Note 7: Tested limits are guaranteed to National's AOQL (Average Outgoing Quality Level).

Note 8: Datasheet min/max specification limits are guaranteed by design, test, or statistical analysis.

Note 9: Shutdown current is measured in a normal room environment. Exposure to direct sunlight will increase I_{SD} by a maximum of $2\mu\text{A}$. The Shutdown pin should be driven as close as possible to GND for minimal shutdown current and to V_{DD} for the best THD performance in PLAY mode. See the **Application Information** section under SHUTDOWN FUNCTION for more information.

Note 10: The performance graphs were taken using the Audio Precision AUX-0025 Switching Amplifier measurement Filter in series with the LC filter on the demo board.

External Components Description

(Figure 1)

Components		Functional Description
1.	C_S	Supply bypass capacitor which provides power supply filtering. Refer to the Power Supply Bypassing section for information concerning proper placement and selection of the supply bypass capacitor.
2.	C_I	Input AC coupling capacitor which blocks the DC voltage at the amplifier's input terminals.

Typical Performance Characteristics

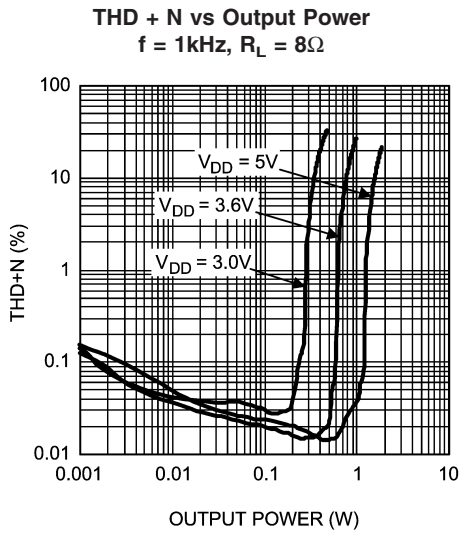

20182706

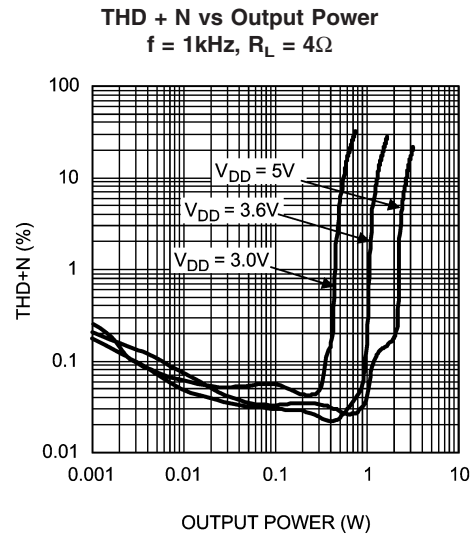

20182707

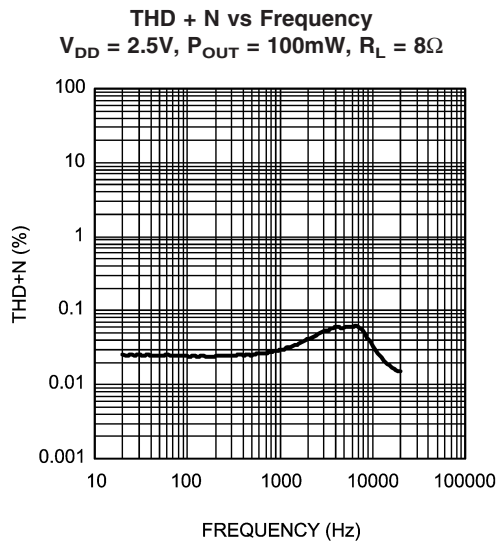

20182708

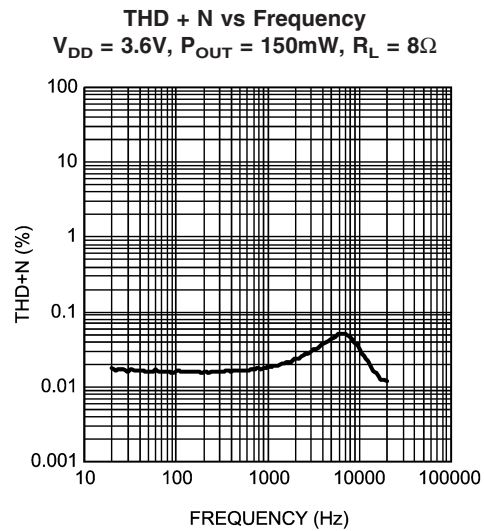

20182709

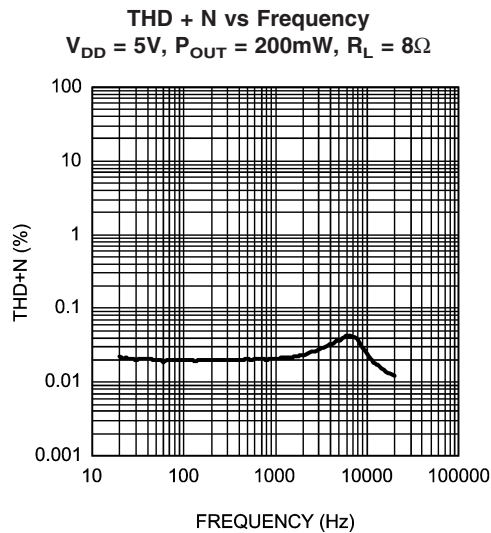

20182710

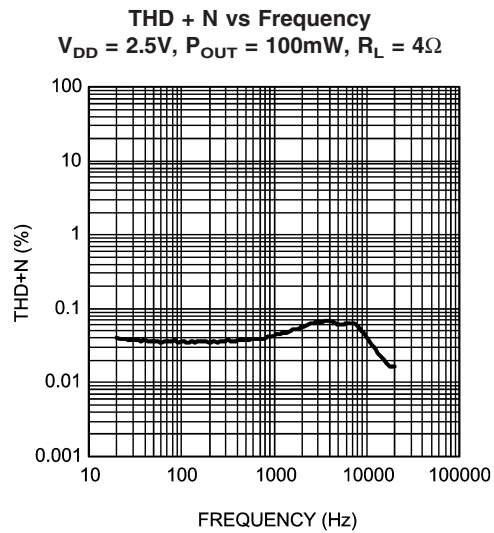

20182711

Typical Performance Characteristics (Continued)

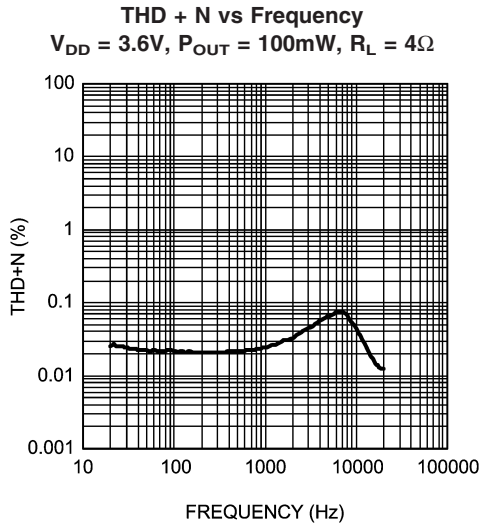

20182712

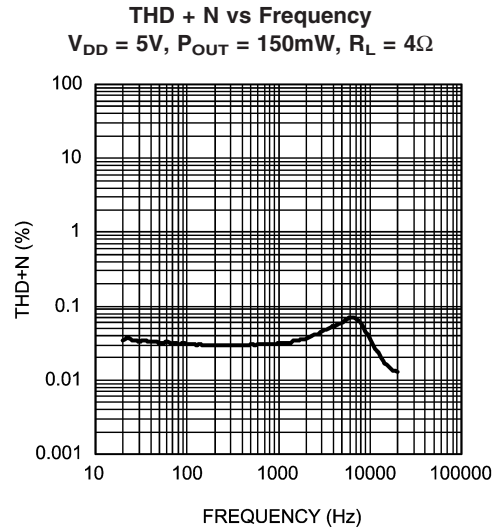

20182713

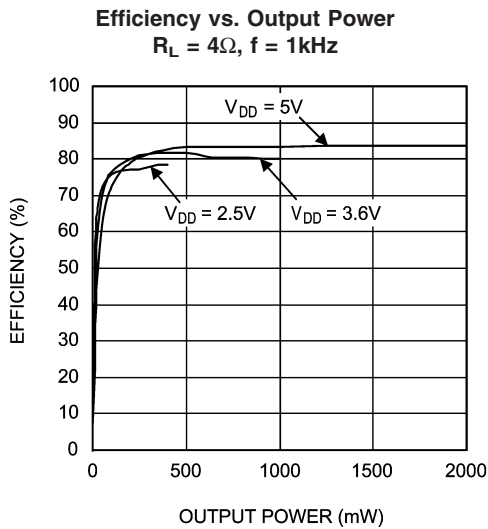

20182714

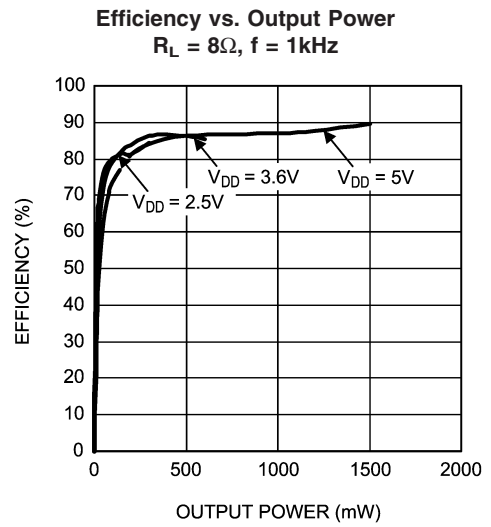

20182715

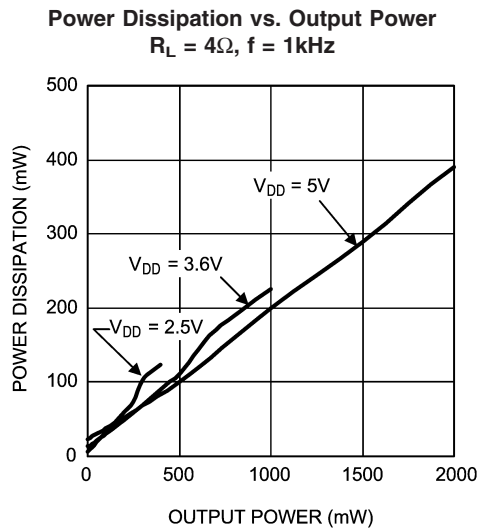

20182716

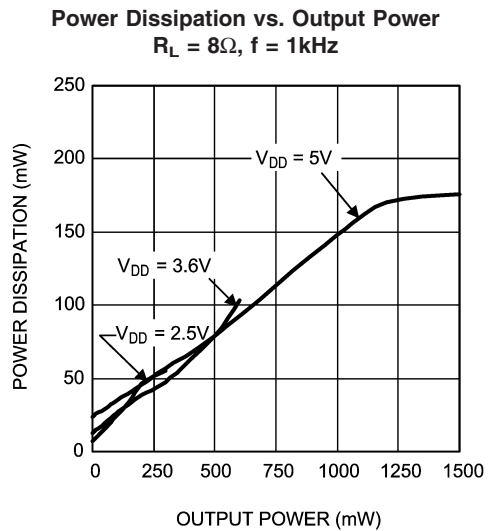

20182717

Typical Performance Characteristics (Continued)

Output Power vs. Supply Voltage
 $R_L = 4\Omega, f = 1\text{kHz}$

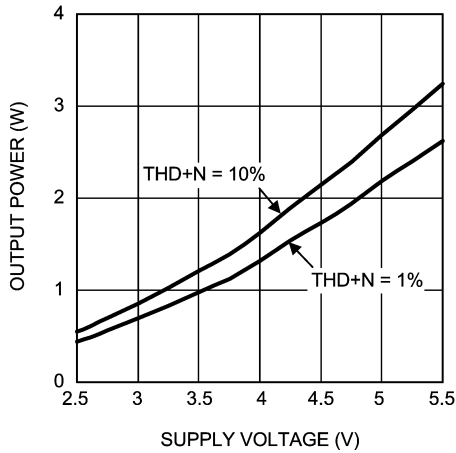

20182718

Output Power vs. Supply Voltage
 $R_L = 8\Omega, f = 1\text{kHz}$

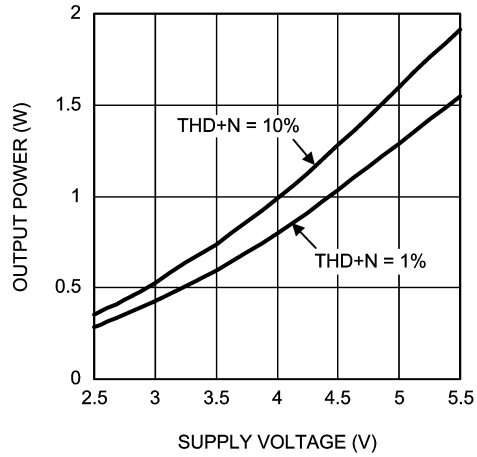

20182719

PSRR vs. Frequency
 $V_{DD} = 3.6\text{V}, V_{RIPPLE} = 200\text{mV}_{P-P}, R_L = 8\Omega$

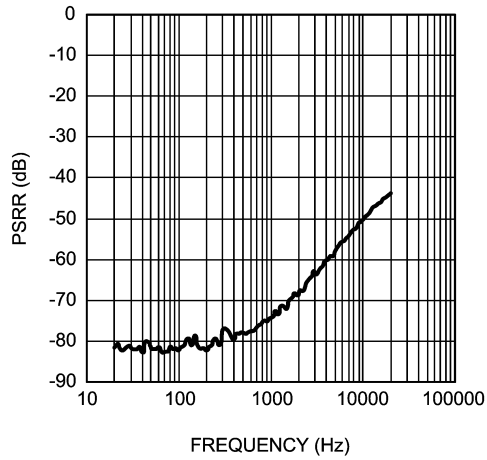

20182720

CMRR vs. Frequency
 $V_{DD} = 3.6\text{V}, V_{CM} = 1\text{V}_{P-P}, R_L = 8\Omega$

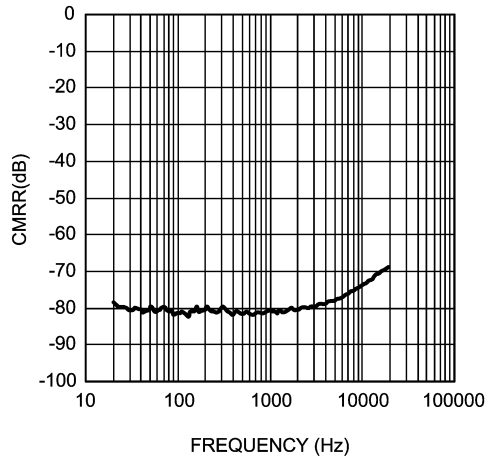

20182729

Supply Current vs. Supply Voltage
 No Load

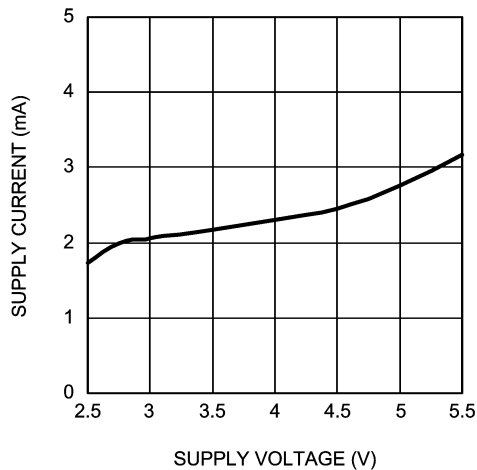

20182730

Shutdown Supply Current vs. Supply Voltage
 No Load

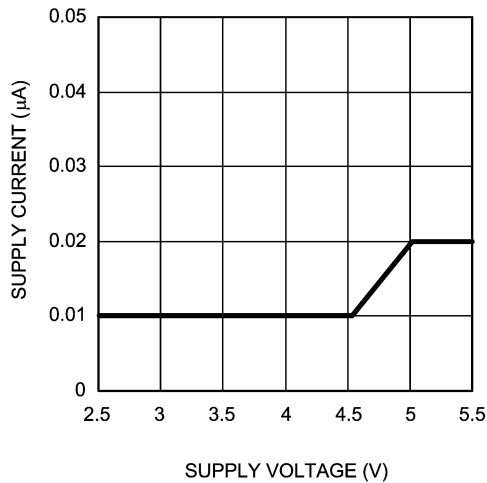

20182731

Typical Performance Characteristics (Continued)

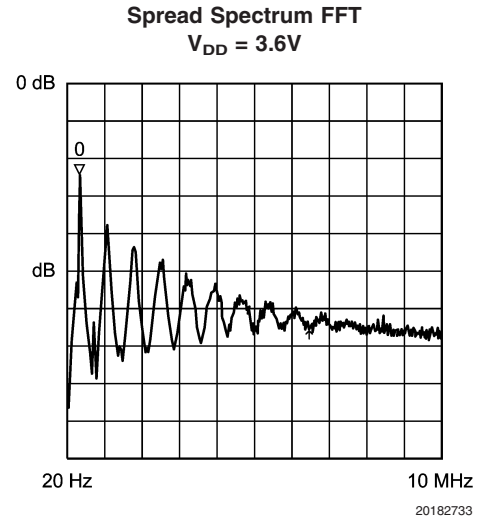
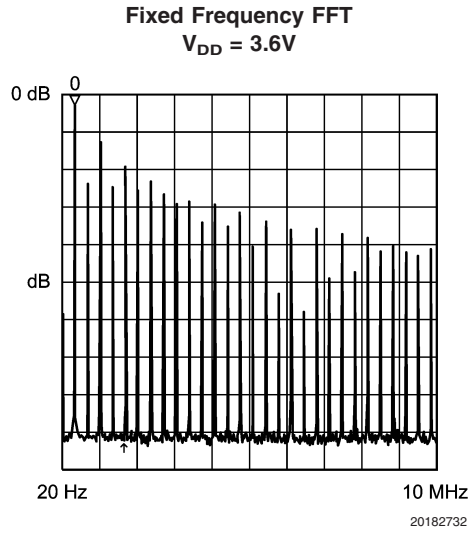

Application Information

GENERAL AMPLIFIER FUNCTION

The LM4675 features a filterless modulation scheme. The differential outputs of the device switch at 300kHz from V_{DD} to GND. When there is no input signal applied, the two outputs (V_{O1} and V_{O2}) switch with a 50% duty cycle, with both outputs in phase. Because the outputs of the LM4675 are differential, the two signals cancel each other. This results in no net voltage across the speaker, thus there is no load current during an idle state, conserving power.

With an input signal applied, the duty cycle (pulse width) of the LM4675 outputs changes. For increasing output voltages, the duty cycle of V_{O1} increases, while the duty cycle of V_{O2} decreases. For decreasing output voltages, the converse occurs, the duty cycle of V_{O2} increases while the duty cycle of V_{O1} decreases. The difference between the two pulse widths yields the differential output voltage.

SPREAD SPECTRUM MODULATION

The LM4675 features a filterless spread spectrum modulation scheme that eliminates the need for output filters, ferrite beads or chokes. The switching frequency varies by TBD% about a 300kHz center frequency, reducing the wideband spectral content, improving EMI emissions radiated by the speaker and associated cables and traces. Where a fixed frequency class D exhibits large amounts of spectral energy at multiples of the switching frequency, the spread spectrum architecture of the LM4675 spreads that energy over a larger bandwidth. The cycle-to-cycle variation of the switching period does not affect the audio reproduction of efficiency.

POWER DISSIPATION AND EFFICIENCY

In general terms, efficiency is considered to be the ratio of useful work output divided by the total energy required to produce it with the difference being the power dissipated, typically, in the IC. The key here is "useful" work. For audio systems, the energy delivered in the audible bands is considered useful including the distortion products of the input signal. Sub-sonic (DC) and super-sonic components (>22kHz) are not useful. The difference between the power flowing from the power supply and the audio band power being transduced is dissipated in the LM4675 and in the transducer load. The amount of power dissipation in the LM4675 is very low. This is because the ON resistance of the switches used to form the output waveforms is typically less than 0.25Ω . This leaves only the transducer load as a potential "sink" for the small excess of input power over audio band output power. The LM4675 dissipates only a fraction of the excess power requiring no additional PCB area or copper plane to act as a heat sink.

DIFFERENTIAL AMPLIFIER EXPLANATION

As logic supply voltages continue to shrink, designers are increasingly turning to differential analog signal handling to preserve signal to noise ratios with restricted voltage swing. The LM4675 is a fully differential amplifier that features differential input and output stages. A differential amplifier amplifies the difference between the two input signals. Traditional audio power amplifiers have typically offered only single-ended inputs resulting in a 6dB reduction in signal to noise ratio relative to differential inputs. The LM4675 also offers the possibility of DC input coupling which eliminates

the two external AC coupling, DC blocking capacitors. The LM4675 can be used, however, as a single ended input amplifier while still retaining its fully differential benefits. In fact, completely unrelated signals may be placed on the input pins. The LM4675 simply amplifies the difference between the signals. A major benefit of a differential amplifier is the improved common mode rejection ratio (CMRR) over single input amplifiers. The common-mode rejection characteristic of the differential amplifier reduces sensitivity to ground offset related noise injection, especially important in high noise applications.

PCB LAYOUT CONSIDERATIONS

As output power increases, interconnect resistance (PCB traces and wires) between the amplifier, load and power supply create a voltage drop. The voltage loss on the traces between the LM4675 and the load results in lower output power and decreased efficiency. Higher trace resistance between the supply and the LM4675 has the same effect as a poorly regulated supply, increased ripple on the supply line also reducing the peak output power. The effects of residual trace resistance increases as output current increases due to higher output power, decreased load impedance or both. To maintain the highest output voltage swing and corresponding peak output power, the PCB traces that connect the output pins to the load and the supply pins to the power supply should be as wide as possible to minimize trace resistance.

The use of power and ground planes will give the best THD+N performance. While reducing trace resistance, the use of power planes also creates parasite capacitors that help to filter the power supply line.

The inductive nature of the transducer load can also result in overshoot on one or both edges, clamped by the parasitic diodes to GND and V_{DD} in each case. From an EMI standpoint, this is an aggressive waveform that can radiate or conduct to other components in the system and cause interference. It is essential to keep the power and output traces short and well shielded if possible. Use of ground planes, beads, and micro-strip layout techniques are all useful in preventing unwanted interference.

As the distance from the LM4675 and the speaker increase, the amount of EMI radiation will increase since the output wires or traces acting as antenna become more efficient with length. What is acceptable EMI is highly application specific. Ferrite chip inductors placed close to the LM4675 may be needed to reduce EMI radiation. The value of the ferrite chip is very application specific.

POWER SUPPLY BYPASSING

As with any power amplifier, proper supply bypassing is critical for low noise performance and high power supply rejection ratio (PSRR). The capacitor (C_S) location should be as close as possible to the LM4675. Typical applications employ a voltage regulator with a $10\mu\text{F}$ and a $0.1\mu\text{F}$ bypass capacitors that increase supply stability. These capacitors do not eliminate the need for bypassing on the supply pin of the LM4675. A $4.7\mu\text{F}$ tantalum capacitor is recommended.

SHUTDOWN FUNCTION

In order to reduce power consumption while not in use, the LM4675 contains shutdown circuitry that reduces current draw to less than $0.01\mu\text{A}$. The trigger point for shutdown is

Application Information (Continued)

shown as a typical value in the Electrical Characteristics Tables and in the Shutdown Hysteresis Voltage graphs found in the **Typical Performance Characteristics** section. It is best to switch between ground and supply for minimum current usage while in the shutdown state. While the LM4675 may be disabled with shutdown voltages in between ground and supply, the idle current will be greater than the typical 0.01µA value. Increased THD may also be observed with voltages less than V_{DD} on the Shutdown pin when in PLAY mode.

The LM4675 has an internal resistor connected between GND and Shutdown pins. The purpose of this resistor is to eliminate any unwanted state changes when the Shutdown pin is floating. The LM4675 will enter the shutdown state when the Shutdown pin is left floating or if not floating, when the shutdown voltage has crossed the threshold. To minimize the supply current while in the shutdown state, the Shutdown pin should be driven to GND or left floating. If the Shutdown pin is not driven to GND, the amount of additional resistor current due to the internal shutdown resistor can be found by Equation (1) below.

$$(V_{SD} - GND) / 300k\Omega \quad (1)$$

With only a 0.5V difference, an additional 1.7µA of current will be drawn while in the shutdown state.

PROPER SELECTION OF EXTERNAL COMPONENTS

The gain of the LM4675 is set by the external resistors, R_i in Figure 1, The Gain is given by Equation (2) below. Best THD+N performance is achieved with a gain of 2V/V (6dB).

$$A_v = 2 * 150 k\Omega / R_i (V/V) \quad (2)$$

It is recommended that resistors with 1% tolerance or better be used to set the gain of the LM4675. The R_i resistors should be placed close to the input pins of the LM4675. Keeping the input traces close to each other and of the same length in a high noise environment will aid in noise rejection due to the good CMRR of the LM4675. Noise coupled onto input traces which are physically close to each other will be common mode and easily rejected by the LM4675.

Input capacitors may be needed for some applications or when the source is single-ended (see Figures 3, 5). Input capacitors are needed to block any DC voltage at the source so that the DC voltage seen between the input terminals of the LM4675 is 0V. Input capacitors create a high-pass filter with the input resistors, R_i . The -3dB point of the high-pass filter is found using Equation (3) below.

$$f_c = 1 / (2\pi R_i C_i) (Hz) \quad (3)$$

The input capacitors may also be used to remove low audio frequencies. Small speakers cannot reproduce low bass frequencies so filtering may be desired. When the LM4675

is using a single-ended source, power supply noise on the ground is seen as an input signal by the +IN input pin that is capacitor coupled to ground (See Figures 5 – 7). Setting the high-pass filter point above the power supply noise frequencies, 217Hz in a GSM phone, for example, will filter out this noise so it is not amplified and heard on the output. Capacitors with a tolerance of 10% or better are recommended for impedance matching.

DIFFERENTIAL CIRCUIT CONFIGURATIONS

The LM4675 can be used in many different circuit configurations. The simplest and best performing is the DC coupled, differential input configuration shown in Figure 2. Equation (2) above is used to determine the value of the R_i resistors for a desired gain.

Input capacitors can be used in a differential configuration as shown in Figure 3. Equation (3) above is used to determine the value of the C_i capacitors for a desired frequency response due to the high-pass filter created by C_i and R_i . Equation (2) above is used to determine the value of the R_i resistors for a desired gain.

The LM4675 can be used to amplify more than one audio source. Figure 4 shows a dual differential input configuration. The gain for each input can be independently set for maximum design flexibility using the R_i resistors for each input and Equation (2). Input capacitors can be used with one or more sources as well to have different frequency responses depending on the source or if a DC voltage needs to be blocked from a source.

SINGLE-ENDED CIRCUIT CONFIGURATIONS

The LM4675 can also be used with single-ended sources but input capacitors will be needed to block any DC at the input terminals. Figure 5 shows the typical single-ended application configuration. The equations for Gain, Equation (2), and frequency response, Equation (3), hold for the single-ended configuration as shown in Figure 5.

When using more than one single-ended source as shown in Figure 6, the impedance seen from each input terminal should be equal. To find the correct values for C_{i3} and R_{i3} connected to the +IN input pin the equivalent impedance of all the single-ended sources are calculated. The single-ended sources are in parallel to each other. The equivalent capacitor and resistor, C_{i3} and R_{i3} , are found by calculating the parallel combination of all C_i values and then all R_i values. Equations (4) and (5) below are for any number of single-ended sources.

$$C_{i3} = C_{i1} + C_{i2} + C_{in} \dots (F) \quad (4)$$

$$R_{i3} = 1 / (1/R_{i1} + 1/R_{i2} + 1/R_{in} \dots) (\Omega) \quad (5)$$

The LM4675 may also use a combination of single-ended and differential sources. A typical application with one single-ended source and one differential source is shown in Figure 7. Using the principle of superposition, the external component values can be determined with the above equations corresponding to the configuration.

Application Information (Continued)

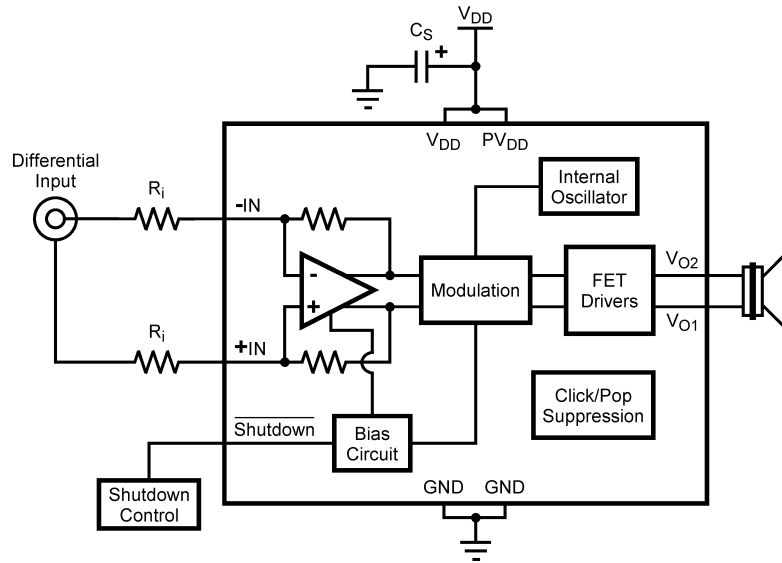

20182722

FIGURE 2. Differential Input Configuration

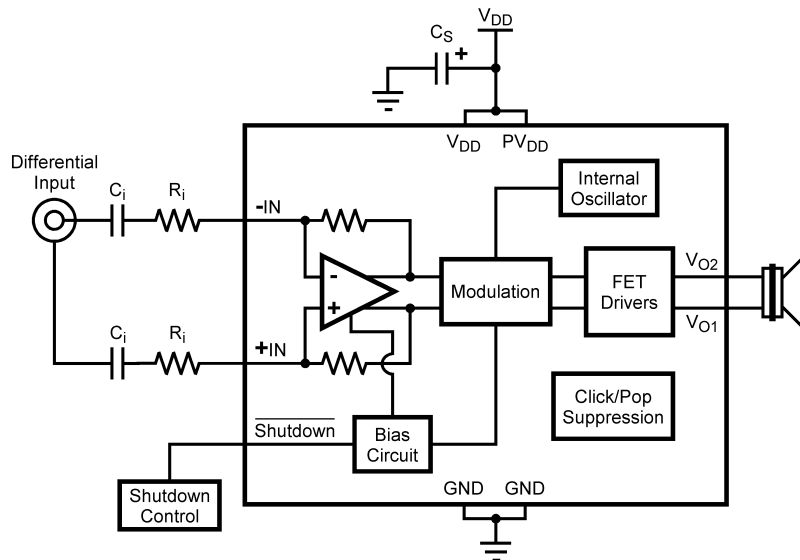

20182723

FIGURE 3. Differential Input Configuration with Input Capacitors

Application Information (Continued)

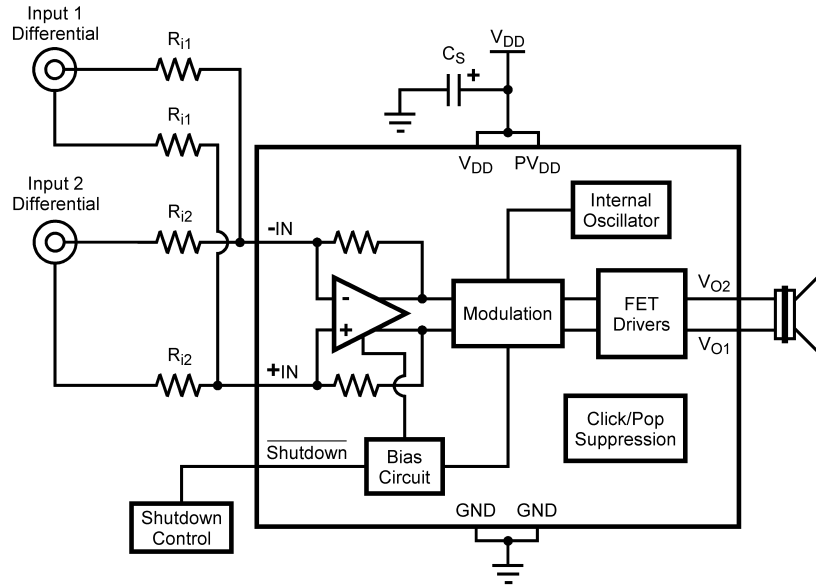

20182724

FIGURE 4. Dual Differential Input Configuration

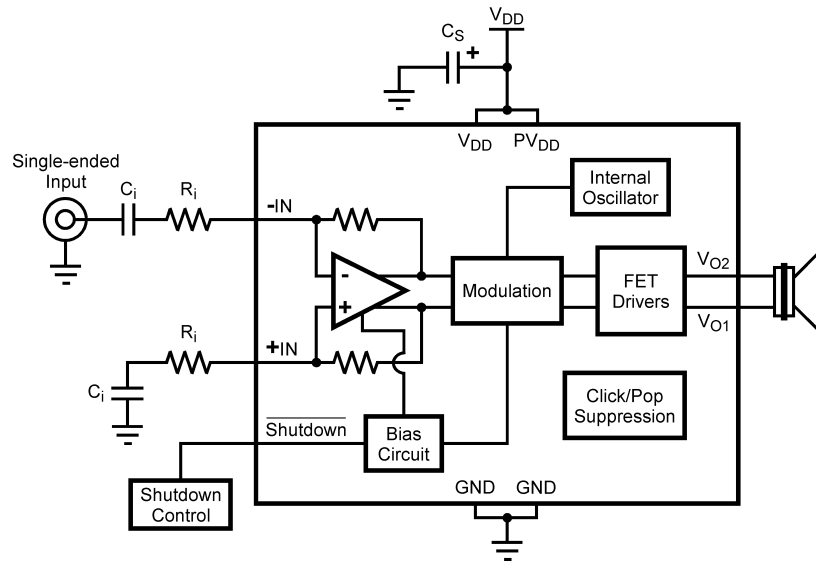

20182725

FIGURE 5. Single-Ended Input Configuration

Application Information (Continued)

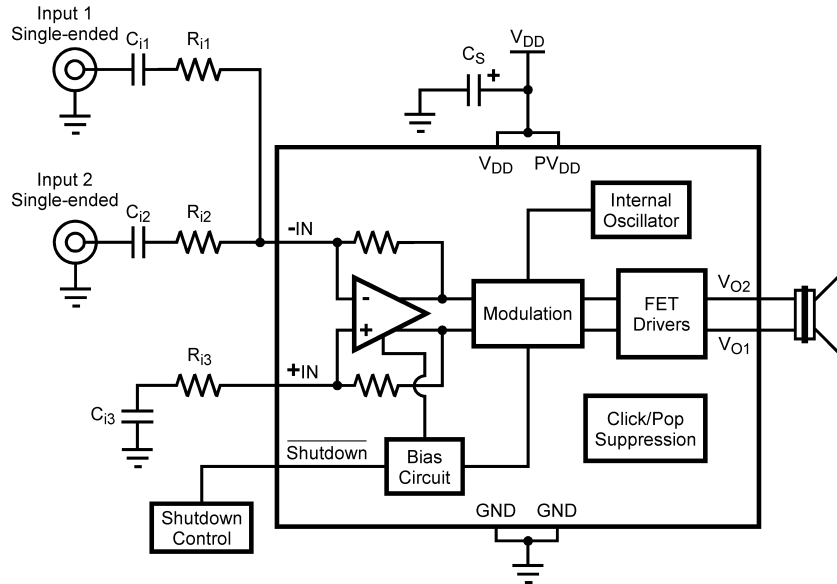

20182726

FIGURE 6. Dual Single-Ended Input Configuration

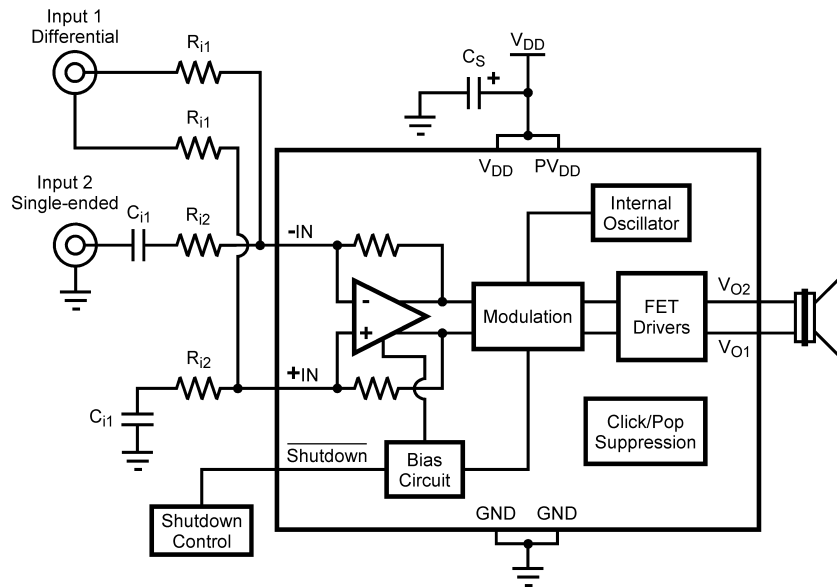

20182727

FIGURE 7. Dual Input with a Single-Ended Input and a Differential Input

Application Information (Continued)

REFERENCE DESIGN BOARD SCHEMATIC

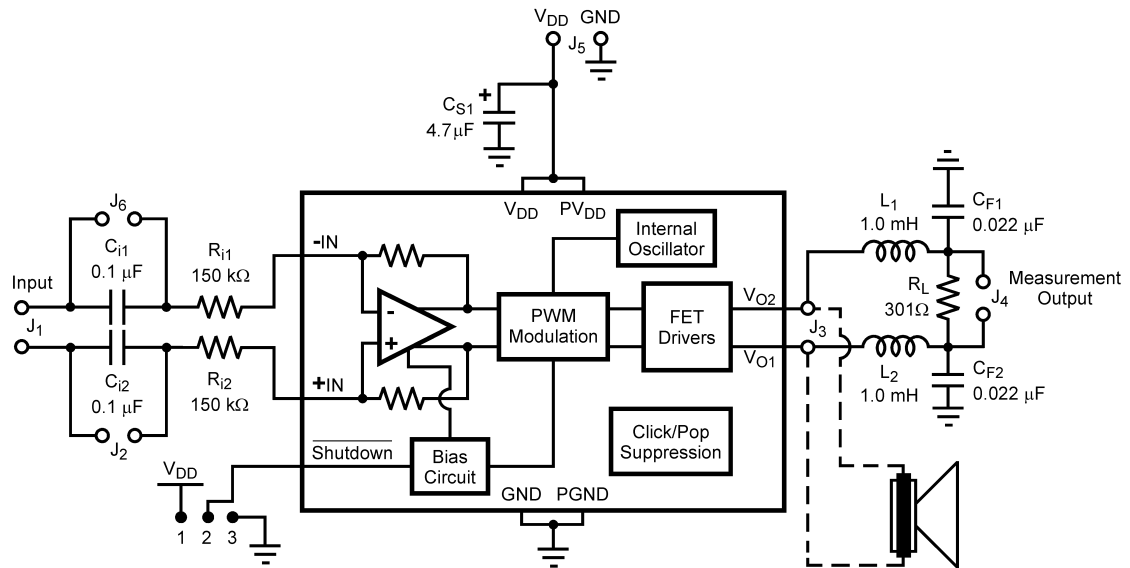

20182728

FIGURE 8.

In addition to the minimal parts required for the application circuit, a measurement filter is provided on the evaluation circuit board so that conventional audio measurements can be conveniently made without additional equipment. This is a balanced input, grounded differential output low pass filter with a 3dB frequency of approximately 35kHz and an on board termination resistor of 300Ω (see schematic). Note that the capacitive load elements are returned to ground. This is not optimal for common mode rejection purposes, but due to the independent pulse format at each output there is a significant amount of high frequency common mode component on the outputs. The grounded capacitive filter elements attenuate this component at the board to reduce the high frequency CMRR requirement placed on the analysis instruments.

Even with the grounded filter the audio signal is still differential, necessitating a differential input on any analysis instrument connected to it. Most lab instruments that feature BNC connectors on their inputs are **NOT** differential responding because the ring of the BNC is usually grounded.

The commonly used Audio Precision analyzer is differential, but its ability to accurately reject high frequency signals is questionable necessitating the on board measurement filter. When in doubt or when the signal needs to be single-ended, use an audio signal transformer to convert the differential output to a single ended output. Depending on the audio transformer's characteristics, there may be some attenuation of the audio signal which needs to be taken into account for correct measurement of performance.

Measurements made at the output of the measurement filter suffer attenuation relative to the primary, unfiltered outputs even at audio frequencies. This is due to the resistance of the inductors interacting with the termination resistor (300Ω) and is typically about -0.25dB (3%). In other words, the voltage levels (and corresponding power levels) indicated through the measurement filter are slightly lower than those that actually occur at the load placed on the unfiltered outputs. This small loss in the filter for measurement gives a lower output power reading than what is really occurring on the unfiltered outputs and its load.

Revision History

Rev	Date	Description
1.0	08/16/06	Initial WEB.

Physical Dimensions inches (millimeters) unless otherwise noted

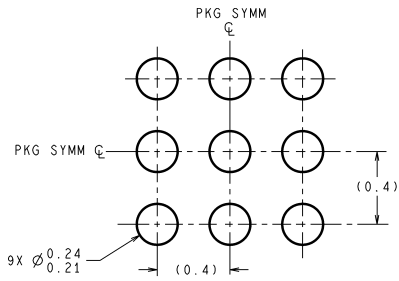

LAND PATTERN RECOMMENDATION

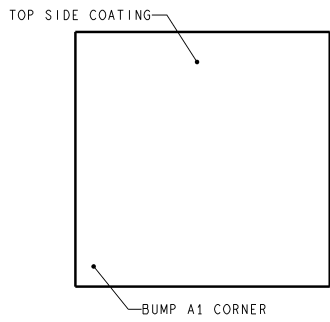

DIMENSIONS ARE IN MILLIMETERS
DIMENSIONS IN () FOR REFERENCE ONLY

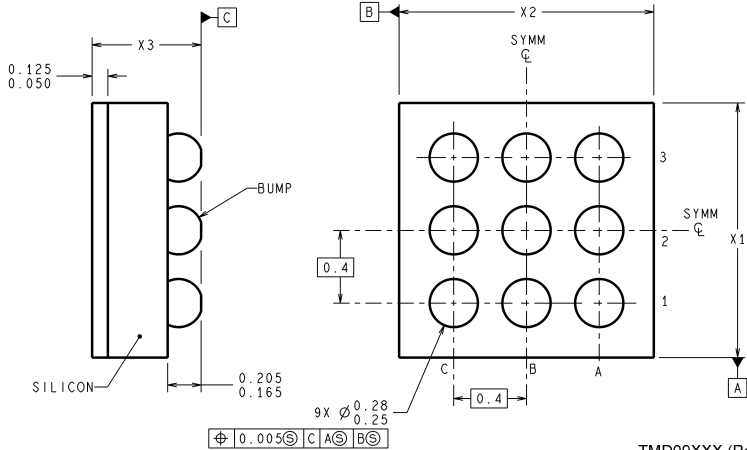

TMD09XXX (Rev A)

9 Bump micro SMD
Order Number LM4675TL
NS Package Number TLA09AAA
X1 = 1.514 X2 = 1.514 X3 = 0.600

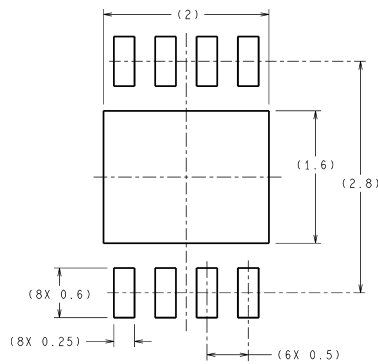

RECOMMENDED LAND PATTERN

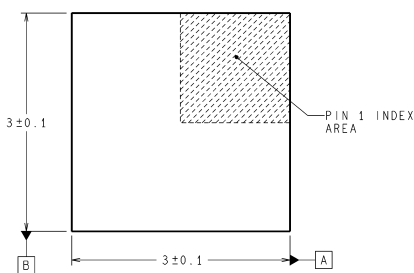

DIMENSIONS ARE IN MILLIMETERS
DIMENSIONS IN () FOR REFERENCE ONLY

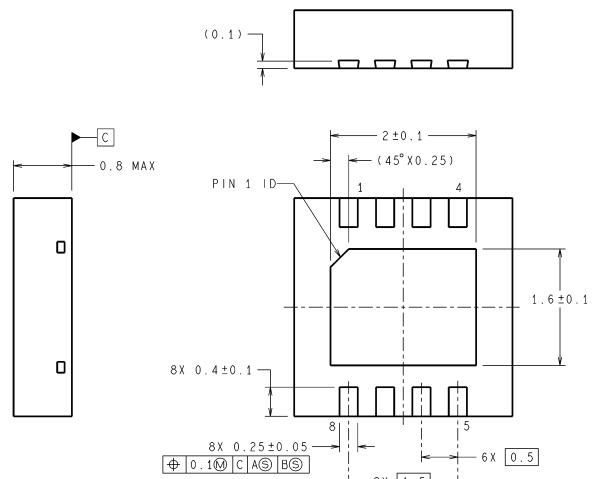

SDA08A (Rev A)

LLP
Order Number LM4675SD
NS Package Number SDA08A

Notes

National does not assume any responsibility for use of any circuitry described, no circuit patent licenses are implied and National reserves the right at any time without notice to change said circuitry and specifications.
 For the most current product information visit us at www.national.com.

LIFE SUPPORT POLICY

NATIONAL'S PRODUCTS ARE NOT AUTHORIZED FOR USE AS CRITICAL COMPONENTS IN LIFE SUPPORT DEVICES OR SYSTEMS WITHOUT THE EXPRESS WRITTEN APPROVAL OF THE PRESIDENT AND GENERAL COUNSEL OF NATIONAL SEMICONDUCTOR CORPORATION. As used herein:

- | | |
|--|---|
| <p>1. Life support devices or systems are devices or systems which, (a) are intended for surgical implant into the body, or (b) support or sustain life, and whose failure to perform when properly used in accordance with instructions for use provided in the labeling, can be reasonably expected to result in a significant injury to the user.</p> | <p>2. A critical component is any component of a life support device or system whose failure to perform can be reasonably expected to cause the failure of the life support device or system, or to affect its safety or effectiveness.</p> |
|--|---|

BANNED SUBSTANCE COMPLIANCE

National Semiconductor follows the provisions of the Product Stewardship Guide for Customers (CSP-9-111C2) and Banned Substances and Materials of Interest Specification (CSP-9-111S2) for regulatory environmental compliance. Details may be found at: www.national.com/quality/green.

Lead free products are RoHS compliant.



National Semiconductor
Americas Customer
Support Center
 Email: new.feedback@nsc.com
 Tel: 1-800-272-9959

National Semiconductor
Europe Customer Support Center
 Fax: +49 (0) 180-530 85 86
 Email: europe.support@nsc.com
 Deutsch Tel: +49 (0) 69 9508 6208
 English Tel: +44 (0) 870 24 0 2171
 Français Tel: +33 (0) 1 41 91 8790

National Semiconductor
Asia Pacific Customer
Support Center
 Email: ap.support@nsc.com

National Semiconductor
Japan Customer Support Center
 Fax: 81-3-5639-7507
 Email: jpn.feedback@nsc.com
 Tel: 81-3-5639-7560

www.national.com