

TC74LCX374F, TC74LCX374FW, TC74LCX374FT

**LOW VOLTAGE OCTAL D-TYPE FLIP-FLOP
WITH 5V TOLERANT INPUTS AND OUTPUTS**

The TC74LCX374 is a high performance CMOS OCTAL D-TYPE FLIP FLOP. Designed for use in 3.3 Volt systems, it achieves high speed operation while maintaining the CMOS low power dissipation.

The device is designed for low-voltage (3.3V) V_{CC} applications, but it could be used to interface to 5V supply environment for both inputs and outputs.

This 8bit D-type flip-flop is controlled by a clock input (CK) and a output enable input (\overline{OE}). When the \overline{OE} input is high, the eight outputs are in a high impedance state. All inputs are equipped with protection circuits against static discharge.

FEATURES

- Low voltage operation : $V_{CC} = 2.0 \sim 3.6V$
- High speed operation : $t_{pd} = 8.5ns$ (Max.)
($V_{CC} = 3.0 \sim 3.6V$)
- Output current : $|I_{OH}| / I_{OL} = 24mA$ (Min.)
($V_{CC} = 3.0V$)
- Latch-up performance : $\pm 500mA$
- Available in JEDEC SOP, EIAJ SOP and TSSOP
- Power down protection is provided on all inputs and outputs.
- Pin and function compatible with the 74 series (74AC/VHC/HC/F/ALS/LS etc.) 374 type.

(Note) The JEDEC SOP (FW) is not available in Japan.

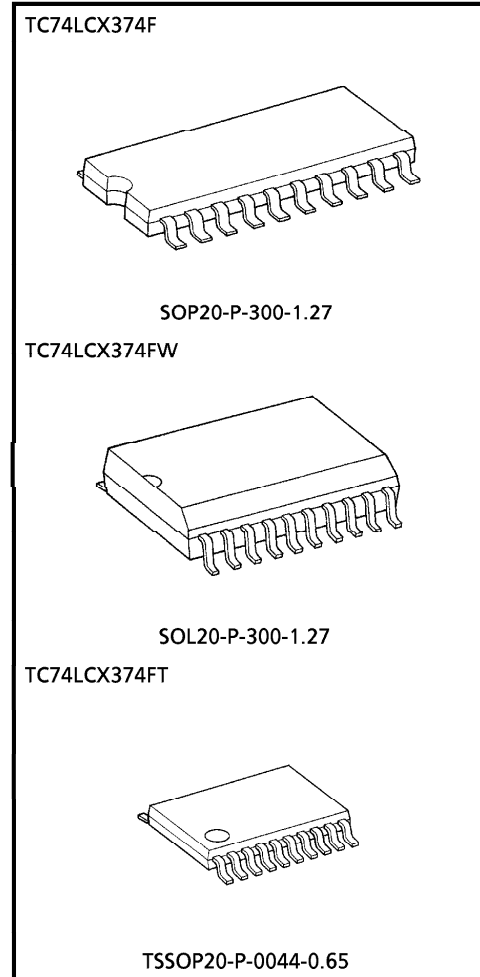

Weight

SOP20-P-300-1.27	: 0.22g (Typ.)
SOL20-P-300-1.27	: 0.46g (Typ.)
TSSOP20-P-0044-0.65	: 0.08g (Typ.)

961001EBA2

● TOSHIBA is continually working to improve the quality and the reliability of its products. Nevertheless, semiconductor devices in general can malfunction or fail due to their inherent electrical sensitivity and vulnerability to physical stress. It is the responsibility of the buyer, when utilizing TOSHIBA products, to observe standards of safety, and to avoid situations in which a malfunction or failure of a TOSHIBA product could cause loss of human life, bodily injury or damage to property. In developing your designs, please ensure that TOSHIBA products are used within specified operating ranges as set forth in the most recent products specifications. Also, please keep in mind the precautions and conditions set forth in the TOSHIBA Semiconductor Reliability Handbook.

PIN ASSIGNMENT

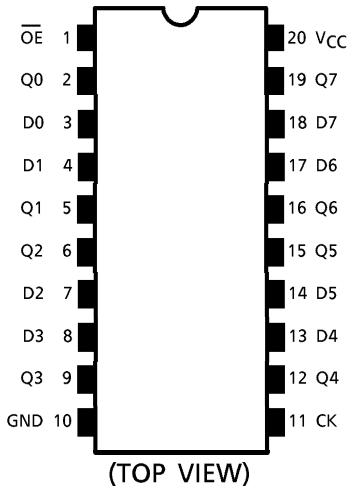

IEC LOGIC SYMBOL

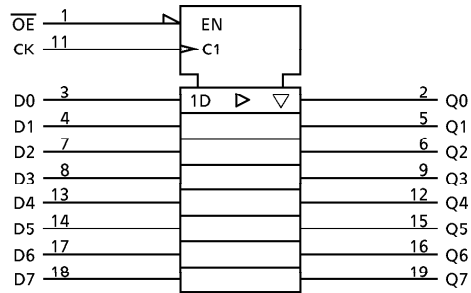

TRUTH TABLE

INPUTS			OUTPUTS
OE	CK	D	
H	X	X	Z
L		X	Qn
L		L	L
L		H	H

X : Don't Care
 Z : High Impedance
 Qn : No change

SYSTEM DIAGRAM

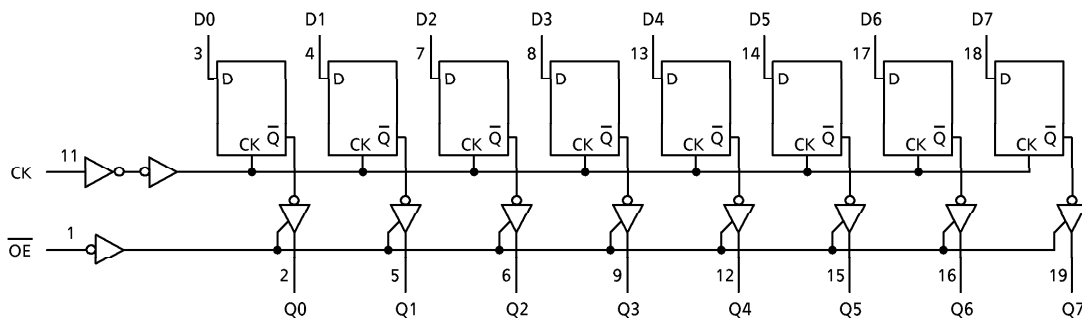

961001EBA2'

- The products described in this document are subject to foreign exchange and foreign trade control laws.
- The information contained herein is presented only as a guide for the applications of our products. No responsibility is assumed by TOSHIBA CORPORATION for any infringements of intellectual property or other rights of the third parties which may result from its use. No license is granted by implication or otherwise under any intellectual property or other rights of TOSHIBA CORPORATION or others.
- The information contained herein is subject to change without notice.

MAXIMUM RATINGS

PARAMETER	SYMBOL	RATING	UNIT
Supply Voltage Range	V_{CC}	-0.5~7.0	V
DC Input Voltage	V_{IN}	-0.5~7.0	V
DC Output Voltage	V_{OUT}	-0.5~7.0 (Note 1)	V
		-0.5~ $V_{CC} + 0.5$ (Note 2)	
Input Diode Current	I_{IK}	-50	mA
Output Diode Current	I_{OK}	± 50 (Note 3)	mA
DC Output Current	I_{OUT}	± 50	mA
Power Dissipation	P_D	180	mW
DC V_{CC} /Ground Current	I_{CC}/I_{GND}	± 100	mA
Storage Temperature	T_{stg}	-65~150	$^{\circ}C$

(Note 1) Output in Off-State

(Note 2) High or Low State. I_{OUT} absolute maximum rating must be observed.

(Note 3) $V_{OUT} < GND$, $V_{OUT} > V_{CC}$

RECOMMENDED OPERATING CONDITIONS

PARAMETER	SYMBOL	RATING	UNIT
Supply Voltage	V_{CC}	2.0~3.6	V
		1.5~3.6 (Note 4)	
Input Voltage	V_{IN}	0~5.5	V
Output Voltage	V_{OUT}	0~5.5 (Note 5)	V
		0~ V_{CC} (Note 6)	
Output Current	I_{OH}/I_{OL}	± 24 (Note 7)	mA
		± 12 (Note 8)	
Operating Temperature	T_{opr}	-40~85	$^{\circ}C$
Input Rise And Fall Time	dt/dv	0~10 (Note 9)	ns/V

(Note 4) Data Retention Only

(Note 5) Output in Off-State

(Note 6) High or Low State

(Note 7) $V_{CC} = 3.0 \sim 3.6V$

(Note 8) $V_{CC} = 2.7 \sim 3.0V$

(Note 9) $V_{IN} = 0.8 \sim 2.0V$, $V_{CC} = 3.0V$

ELECTRICAL CHARACTERISTICS

DC characteristics (Ta = -40~85°C)

PARAMETER		SYMBOL	TEST CONDITION		V _{CC} (V)	MIN.	MAX.	UNIT
Input Voltage	"H" Level	V _{IH}			2.7~3.6	2.0	—	V
	"L" Level	V _{IL}			2.7~3.6	—	0.8	
Output Voltage	"H" Level	V _{OH}	V _{IN} = V _{IH} or V _{IL}	I _{OH} = -100μA	2.7~3.6	V _{CC} - 0.2	—	V
				I _{OH} = -12mA	2.7	2.2	—	
				I _{OH} = -18mA	3.0	2.4	—	
				I _{OH} = -24mA	3.0	2.2	—	
	"L" Level	V _{OL}	V _{IN} = V _{IH} or V _{IL}	I _{OL} = 100μA	2.7~3.6	—	0.2	
				I _{OL} = 12mA	2.7	—	0.4	
				I _{OL} = 16mA	3.0	—	0.4	
				I _{OL} = 24mA	3.0	—	0.55	
Input Leakage Current		I _{IN}	V _{IN} = 0~5.5V		2.7~3.6	—	±5.0	μA
3-State Output Off-State Current		I _{OZ}	V _{IN} = V _{IH} or V _{IL} V _{OUT} = 0~5.5V		2.7~3.6	—	±5.0	μA
Power Off Leakage Current		I _{OFF}	V _{IN} / V _{OUT} = 5.5V		0	—	10.0	μA
Quiescent Supply Current		I _{CC}	V _{IN} = V _{CC} or GND		2.7~3.6	—	10.0	μA
			V _{IN} / V _{OUT} = 3.6~5.5V		2.7~3.6	—	±10.0	
Increase In I _{CC} Per Input		ΔI _{CC}	V _{IH} = V _{CC} - 0.6V		2.7~3.6	—	500	μA

AC characteristics (Ta = -40~85°C)

PARAMETER	SYMBOL	TEST CONDITION	V _{CC} (V)	MIN.	MAX.	UNIT
Maximum Clock Frequency	f _{MAX}	(Fig.1, 2)	2.7	—	—	MHz
			3.3 ± 0.3	150	—	
Propagation Delay Time (CK-Q)	t _{pLH} t _{pHL}	(Fig.1, 2)	2.7	—	9.5	ns
			3.3 ± 0.3	1.5	8.5	
Output Enable Time	t _{pZL} t _{pZH}	(Fig.1, 3)	2.7	—	9.5	ns
			3.3 ± 0.3	1.5	8.5	
Output Disable Time	t _{pLZ} t _{pHZ}	(Fig.1, 3)	2.7	—	8.5	ns
			3.3 ± 0.3	1.5	7.5	
Minimum Pulse Width (CK)	t _w (H) t _w (L)	(Fig.1, 2)	2.7	4.0	—	ns
			3.3 ± 0.3	3.3	—	
Minimum Set-Up Time	t _s	(Fig.1, 2)	2.7	2.5	—	ns
			3.3 ± 0.3	2.5	—	
Minimum Hold Time	t _h	(Fig.1, 2)	2.7	1.5	—	ns
			3.3 ± 0.3	1.5	—	
Output To Output Skew	t _{osLH} t _{osHL}	(Note 10)	2.7	—	—	ns
			3.3 ± 0.3	—	1.0	

(Note 10) Parameter guaranteed by design.
 (t_{osLH} = |t_{pLHm} - t_{pLHn}|, t_{osHL} = |t_{pHLm} - t_{pHLn}|)

DYNAMIC SWITCHING CHARACTERISTICS (Ta = 25°C, Input t_r = t_f = 2.5ns, C_L = 50pF, R_L = 500Ω)

PARAMETER	SYMBOL	TEST CONDITION	V _{CC} (V)	TYP.	UNIT
Quiet Output Maximum Dynamic V _{OL}	V _{OLP}	V _{IH} = 3.3V, V _{IL} = 0V	3.3	0.8	V
Quiet Output Minimum Dynamic V _{OL}	V _{OLV}	V _{IH} = 3.3V, V _{IL} = 0V	3.3	0.8	V

CAPACITIVE CHARACTERISTICS (Ta = 25°C)

PARAMETER	SYMBOL	TEST CONDITION	V _{CC} (V)	TYP.	UNIT
Input Capacitance	C _{IN}	—	3.3	7	pF
Output Capacitance	C _{OUT}		3.3	8	pF
Power Dissipation Capacitance	C _{PD}	f _{IN} = 10MHz (Note 11)	3.3	25	pF

(Note 11) C_{PD} is defined as the value of the internal equivalent capacitance which is calculated from the operating current consumption.
 Average operating current can be obtained by the equation :
 I_{CC} (opr.) = C_{PD} · V_{CC} · f_{IN} + I_{CC} / 8 (per bit)

TEST CIRCUIT

Fig.1

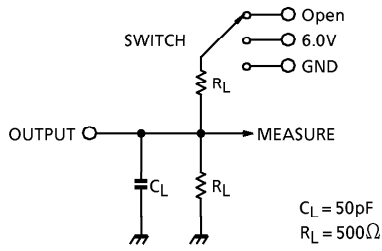

PARAMETER	SWITCH
t_{pLH}, t_{pHL}	Open
t_{pLZ}, t_{pZL}	6.0V
t_{pHZ}, t_{pZH}	GND
t_w, t_s, t_h, f_{MAX}	Open

AC WAVEFORM

Fig.2 $t_{pLH}, t_{pHL}, t_w, t_s, t_h$

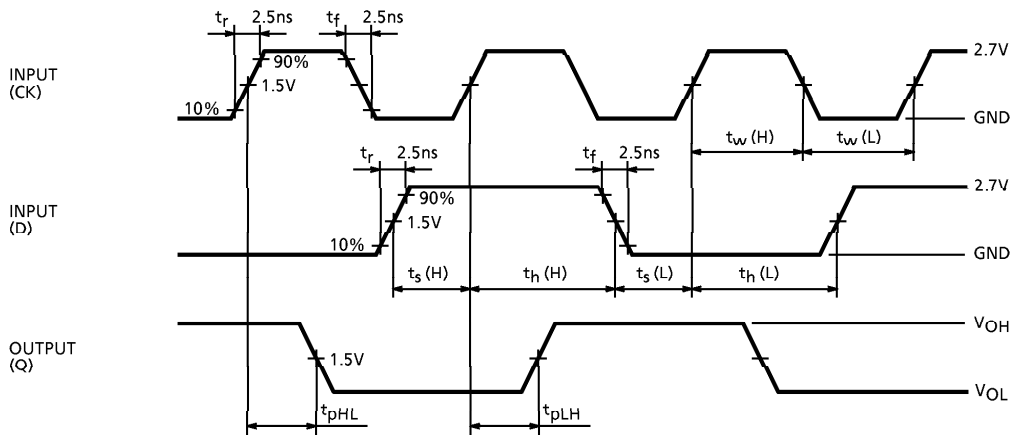
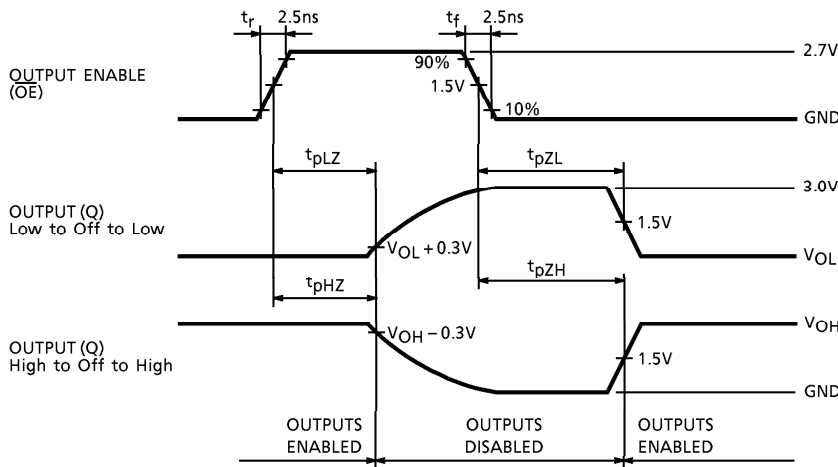
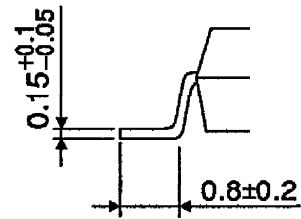
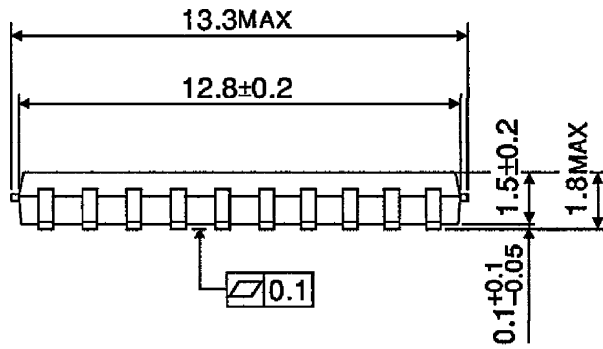
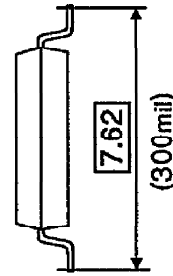
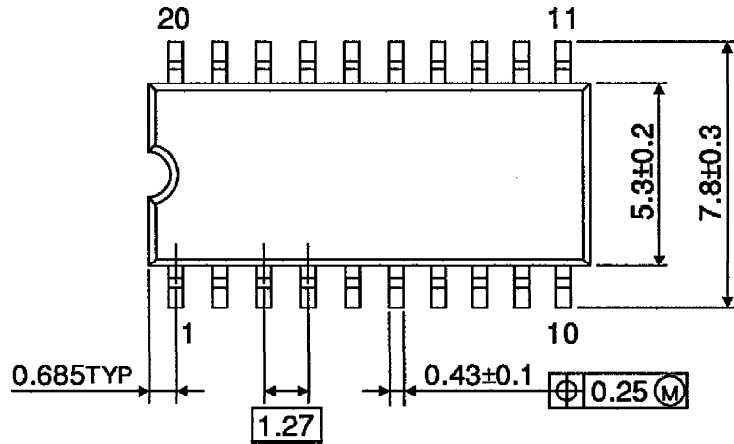

Fig.3 $t_{pLZ}, t_{pHZ}, t_{pZL}, t_{pZH}$



OUTLINE DRAWING
SOP20-P-300-1.27

Unit : mm



Weight : 0.22g (Typ.)

OUTLINE DRAWING
SOL20-P-300-1.27

Unit : mm

(Note) This package is not available in Japan.

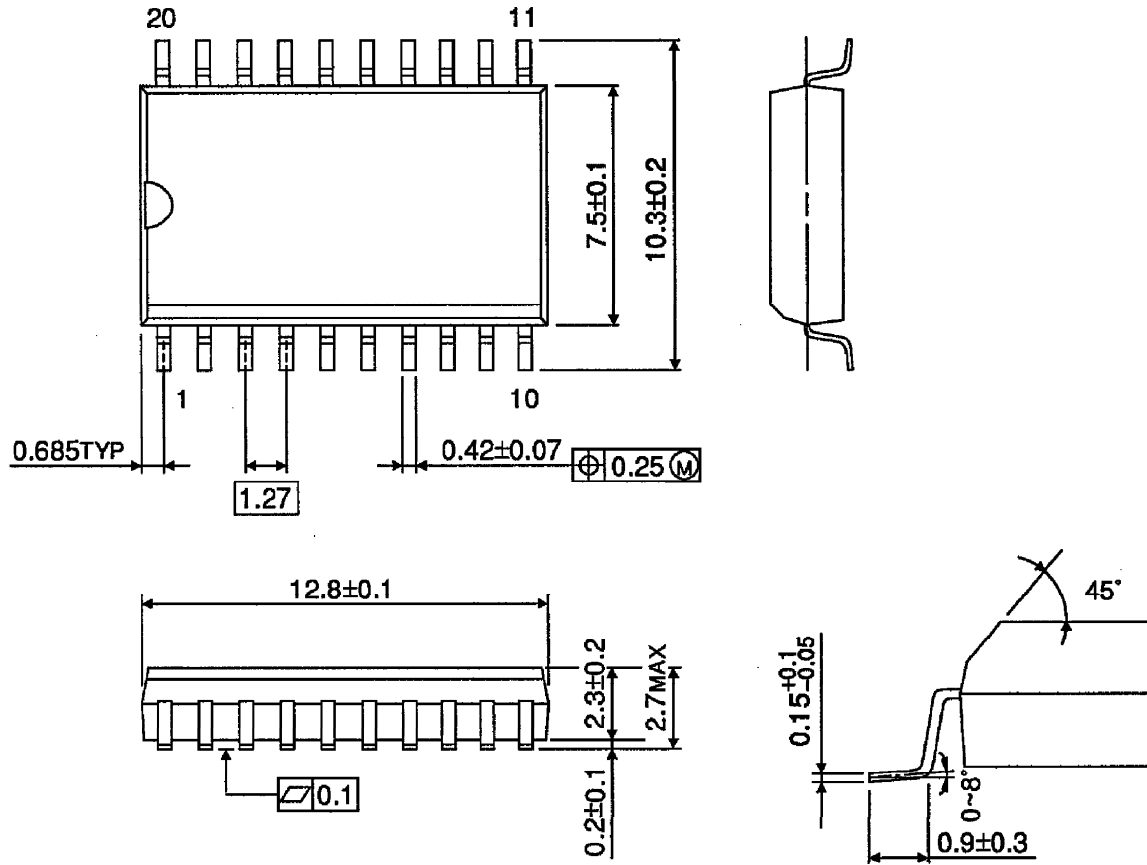

Weight : 0.46g (Typ.)

OUTLINE DRAWING
TSSOP20-P-0044-0.65

Unit : mm

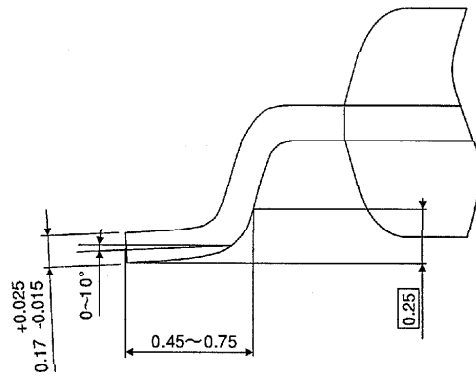
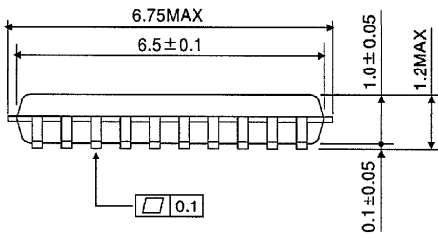
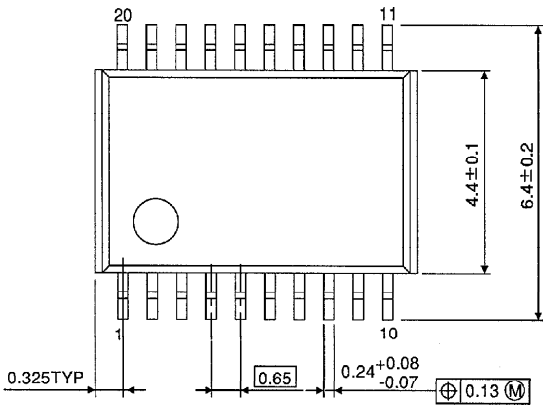

Weight : 0.08g (Typ.)