

## TC74LCX245F, TC74LCX245FT, TC74LCX245FK

Low-Voltage Octal Bus Transceiver with 5-V Tolerant Inputs and Outputs

The TC74LCX245 is a high-performance CMOS octal bus transceiver. Designed for use in 3.3-V systems, it achieves high-speed operation while maintaining the CMOS low power dissipation.

The device is designed for low-voltage (3.3 V) VCC applications, but it could be used to interface to 5-V supply environment for both inputs and outputs.

The direction of data transmission is determined by the level of the DIR input. The enable input ( $\overline{OE}$ ) can be used to disable the device so that the busses are effectively isolated.

All inputs are equipped with protection circuits against static discharge.

### Features (Note)

- Low-voltage operation:  $V_{CC} = 2.0$  to  $3.6$  V
- High-speed operation:  $t_{pd} = 7.0$  ns (max) ( $V_{CC} = 3.0$  to  $3.6$  V)
- Output current:  $|I_{OH}|/I_{OL} = 24$  mA (min) ( $V_{CC} = 3.0$  V)
- Latch-up performance:  $-500$  mA
- Available in JEITA SOP, TSSOP and VSSOP (US)
- Bidirectional interface between 5.0 V and 3.3 V signals
- Power-down protection provided on all inputs and outputs
- Pin and function compatible with the 74 series (74AC/VHC/HC/F/ALS/LS etc.) 245 type

Note: Do not apply a signal to any bus pins when it is in the output mode. Damage may result.  
All floating (high impedance) bus pins must have their input levels fixed by means of pull-up or pull-down resistors.

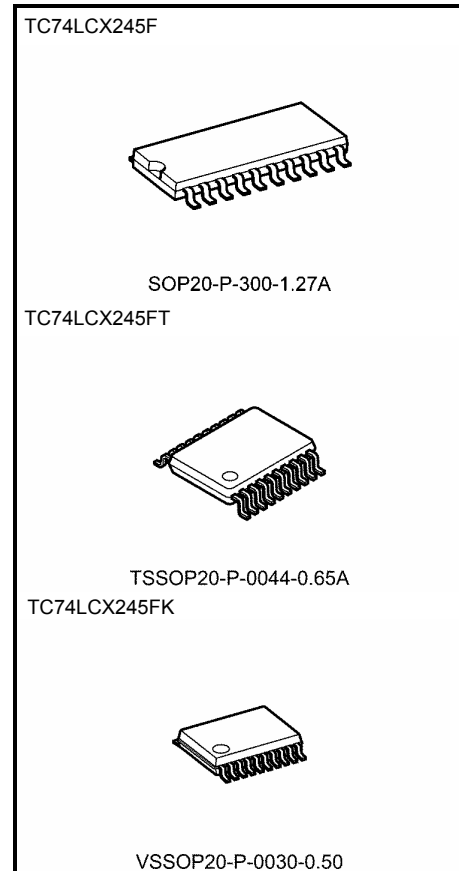

### Weight

SOP20-P-300-1.27A	: 0.22g (typ.)
TSSOP20-P-0044-0.65A	: 0.08 g (typ.)
VSSOP20-P-0030-0.50	: 0.03 g (typ.)

## Pin Assignment (top view)

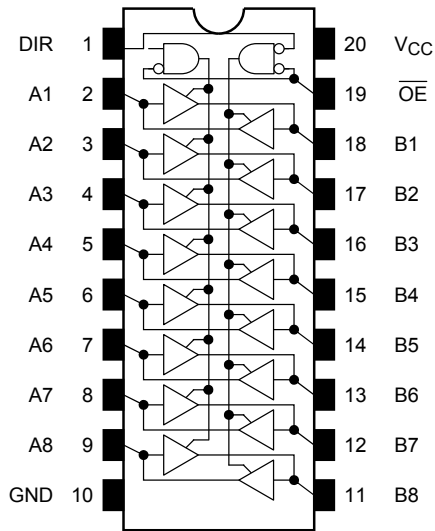

## IEC Logic Symbol

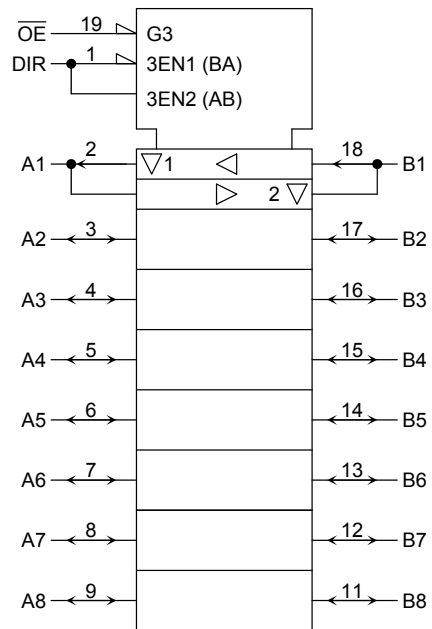

## Truth Table

Inputs		Outputs	Function	
$\overline{OE}$	DIR		A-Bus	B-Bus
L	L	A = B	Output	Input
L	H	B = A	Input	Output
H	X	Z	Z	

X: Don't care

Z: High impedance

## Absolute Maximum Ratings (Note 1)

Characteristics	Symbol	Rating	Unit
Power supply voltage	$V_{CC}$	-0.5 to 7.0	V
DC input voltage (DIR, $\overline{OE}$ )	$V_{IN}$	-0.5 to 7.0	V
DC bus I/O voltage	$V_{I/O}$	-0.5 to 7.0 (Note 2)	V
		-0.5 to $V_{CC} + 0.5$ (Note 3)	
Input diode current	$I_{IK}$	-50	mA
Output diode current	$I_{OK}$	$\pm 50$ (Note 4)	mA
DC output current	$I_{OUT}$	$\pm 50$	mA
Power dissipation	$P_D$	180	mW
DC $V_{CC}$ /ground current	$I_{CC}/I_{GND}$	$\pm 100$	mA
Storage temperature	$T_{stg}$	-65 to 150	$^{\circ}C$

Note 1: Exceeding any of the absolute maximum ratings, even briefly, lead to deterioration in IC performance or even destruction.

Using continuously under heavy loads (e.g. the application of high temperature/current/voltage and the significant change in temperature, etc.) may cause this product to decrease in the reliability significantly even if the operating conditions (i.e. operating temperature/current/voltage, etc.) are within the absolute maximum ratings and the operating ranges.

Please design the appropriate reliability upon reviewing the Toshiba Semiconductor Reliability Handbook ("Handling Precautions"/"Derating Concept and Methods") and individual reliability data (i.e. reliability test report and estimated failure rate, etc).

Note 2: Output in OFF state

Note 3: High or low state.  $I_{OUT}$  absolute maximum rating must be observed.

Note 4:  $V_{OUT} < GND$ ,  $V_{OUT} > V_{CC}$

## Operating Ranges (Note 1)

Characteristics	Symbol	Rating	Unit
Power supply voltage	$V_{CC}$	2.0 to 3.6	V
		1.5 to 3.6 (Note 2)	
Input voltage (DIR, $\overline{OE}$ )	$V_{IN}$	0 to 5.5	V
Bus I/O voltage	$V_{I/O}$	0 to 5.5 (Note 3)	V
		0 to $V_{CC}$ (Note 4)	
Output current	$I_{OH}/I_{OL}$	$\pm 24$ (Note 5)	mA
		$\pm 12$ (Note 6)	
Operating temperature	$T_{opr}$	-40 to 85	$^{\circ}C$
Input rise and fall time	$dt/dv$	0 to 10 (Note 7)	ns/V

Note 1: The operating ranges are required to ensure the normal operation of the device. Unused inputs and bus inputs must be tied to either  $V_{CC}$  or  $GND$ . Please connect both bus inputs and the bus outputs with  $V_{CC}$  or  $GND$  when the I/O of the bus terminal changes by the function. In this case, please note that the output is not short-circuited.

Note 2: Data retention only

Note 3: Output in OFF state

Note 4: High or low state

Note 5:  $V_{CC} = 3.0$  to  $3.6$  V

Note 6:  $V_{CC} = 2.7$  to  $3.0$  V

Note 7:  $V_{IN} = 0.8$  to  $2.0$  V,  $V_{CC} = 3.0$  V

## Electrical Characteristics

### DC Characteristics (Ta = -40 to 85°C)

Characteristics		Symbol	Test Condition	V <sub>CC</sub> (V)	Min	Max	Unit
Input voltage	H-level	V <sub>IH</sub>	—	2.7 to 3.6	2.0	—	V
	L-level	V <sub>IL</sub>	—	2.7 to 3.6	—	0.8	
Output voltage	H-level	V <sub>OH</sub>	V <sub>IN</sub> = V <sub>IH</sub> or V <sub>IL</sub>	I <sub>OH</sub> = -100 μA	2.7 to 3.6	V <sub>CC</sub> - 0.2	V
				I <sub>OH</sub> = -12 mA	2.7	2.2	
				I <sub>OH</sub> = -18 mA	3.0	2.4	
				I <sub>OH</sub> = -24 mA	3.0	2.2	
	L-level	V <sub>OL</sub>	V <sub>IN</sub> = V <sub>IH</sub> or V <sub>IL</sub>	I <sub>OL</sub> = 100 μA	2.7 to 3.6	—	0.2
				I <sub>OL</sub> = 12 mA	2.7	—	0.4
				I <sub>OL</sub> = 16 mA	3.0	—	0.4
				I <sub>OL</sub> = 24 mA	3.0	—	0.55
Input leakage current		I <sub>IN</sub>	V <sub>IN</sub> = 0 to 5.5 V	2.7 to 3.6	—	±5.0	μA
3-state output OFF state current		I <sub>OZ</sub>	V <sub>IN</sub> = V <sub>IH</sub> or V <sub>IL</sub> V <sub>OUT</sub> = 0 to 5.5 V	2.7 to 3.6	—	±5.0	μA
Power-off leakage current		I <sub>OFF</sub>	V <sub>IN</sub> /V <sub>OUT</sub> = 5.5 V	0	—	10.0	μA
Quiescent supply current		I <sub>CC</sub>	V <sub>IN</sub> = V <sub>CC</sub> or GND	2.7 to 3.6	—	10.0	μA
			V <sub>IN</sub> /V <sub>OUT</sub> = 3.6 to 5.5 V	2.7 to 3.6	—	±10.0	
Increase in I <sub>CC</sub> per input		ΔI <sub>CC</sub>	V <sub>IH</sub> = V <sub>CC</sub> - 0.6 V	2.7 to 3.6	—	500	

### AC Characteristics (Ta = -40 to 85°C)

Characteristics		Symbol	Test Condition	V <sub>CC</sub> (V)	Min	Max	Unit
Propagation delay time	t <sub>pLH</sub> t <sub>pHL</sub>	Figure 1, Figure 2		2.7	—	8.0	ns
				3.3 ± 0.3	1.5	7.0	
Output enable time	t <sub>pZL</sub> t <sub>pZH</sub>	Figure 1, Figure 3		2.7	—	9.5	ns
				3.3 ± 0.3	1.5	8.5	
Output disable time	t <sub>pLZ</sub> t <sub>pHZ</sub>	Figure 1, Figure 3		2.7	—	8.5	ns
				3.3 ± 0.3	1.5	7.5	
Output to output skew	t <sub>osLH</sub> t <sub>osHL</sub>	(Note)		2.7	—	—	ns
				3.3 ± 0.3	—	1.0	

Note: Parameter guaranteed by design.  
 (t<sub>osLH</sub> = |t<sub>pLHm</sub> - t<sub>pLHn</sub>|, t<sub>osHL</sub> = |t<sub>pHLm</sub> - t<sub>pHLn</sub>|)

### Dynamic Switching Characteristics (Ta = 25°C, input: tr = tf = 2.5 ns, CL = 50 pF, RL = 500 Ω)

Characteristics	Symbol	Test Condition	VCC (V)	Typ.	Unit
			3.3		
Quiet output maximum dynamic VOL	VOLP	VIH = 3.3 V, VIL = 0 V	3.3	0.8	V
Quiet output minimum dynamic VOL	VOLV	VIH = 3.3 V, VIL = 0 V	3.3	0.8	V

### Capacitive Characteristics (Ta = 25°C)

Characteristics	Symbol	Test Condition	VCC (V)	Typ.	Unit
			3.3		
Input capacitance	CIN	DIR, OE	3.3	7	pF
Bus input capacitance	CI/O	An, Bn	3.3	8	pF
Power dissipation capacitance	CPD	fIN = 10 MHz (Note)	3.3	25	pF

Note: CPD is defined as the value of the internal equivalent capacitance which is calculated from the operating current consumption.

Average operating current can be obtained by the equation:

$$I_{CC(opr)} = C_{PD} \cdot V_{CC} \cdot f_{IN} + I_{CC}/8 \text{ (per bit)}$$

### AC Test Circuit

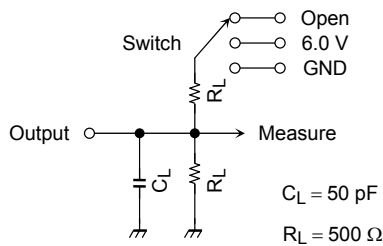

Parameter	Switch
t <sub>pLH</sub> , t <sub>pHL</sub>	Open
t <sub>pLZ</sub> , t <sub>pZL</sub>	6.0 V
t <sub>pHZ</sub> , t <sub>pZH</sub>	GND

Figure 1

### AC Waveform

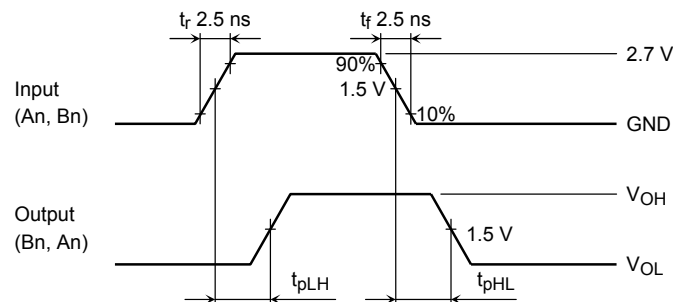
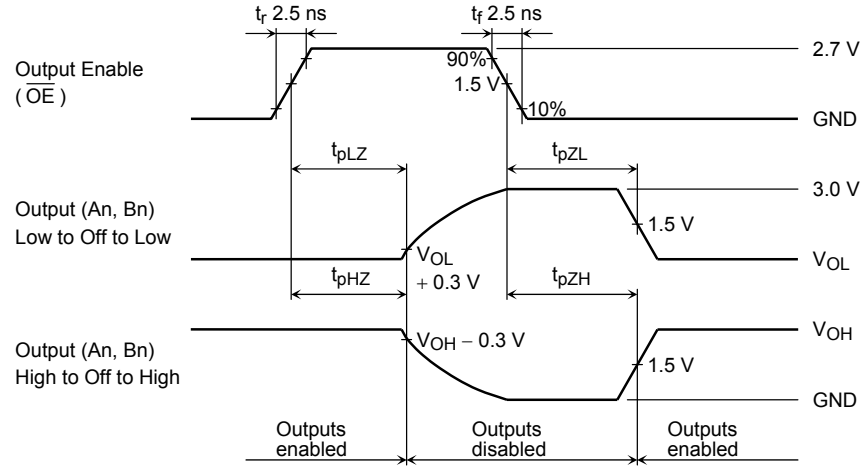

Figure 2 t<sub>pLH</sub>, t<sub>pHL</sub>

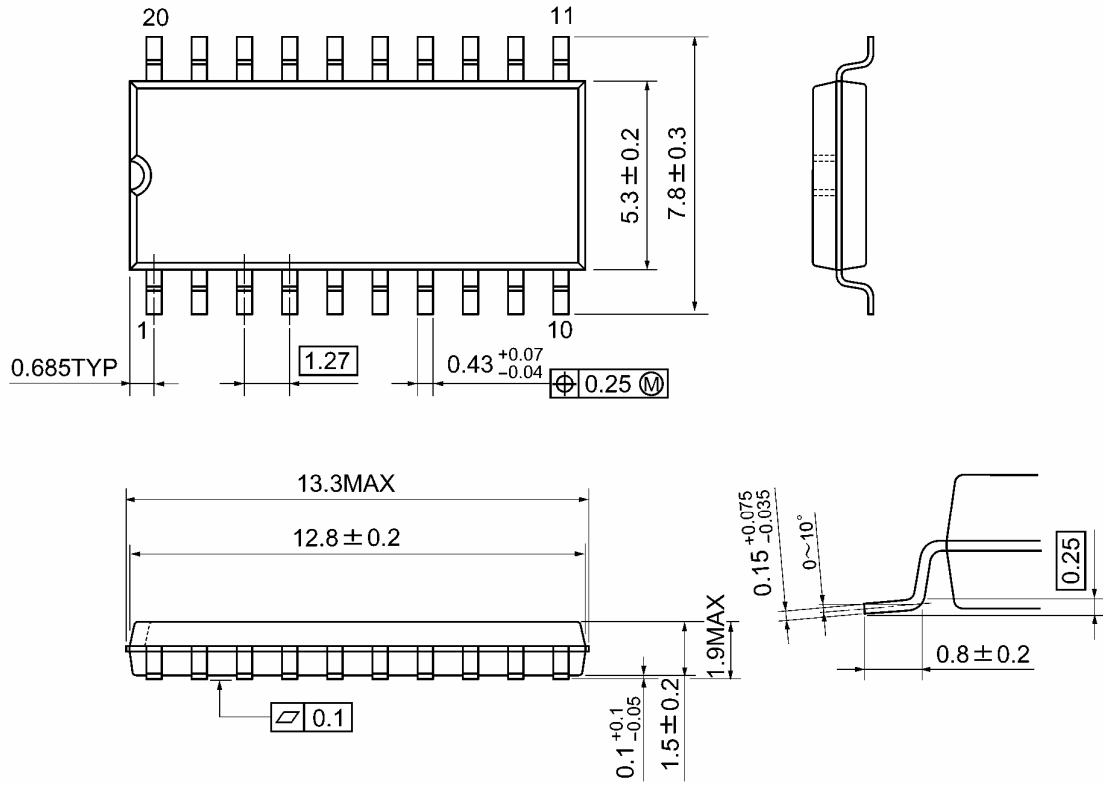

**Figure 3**  $t_{pLZ}$ ,  $t_{pHZ}$ ,  $t_{pZL}$ ,  $t_{pZH}$

## Package Dimensions

SOP20-P-300-1.27A

Unit: mm



Weight: 0.22 g (typ.)

## Package Dimensions

TSSOP20-P-0044-0.65A

Unit: mm

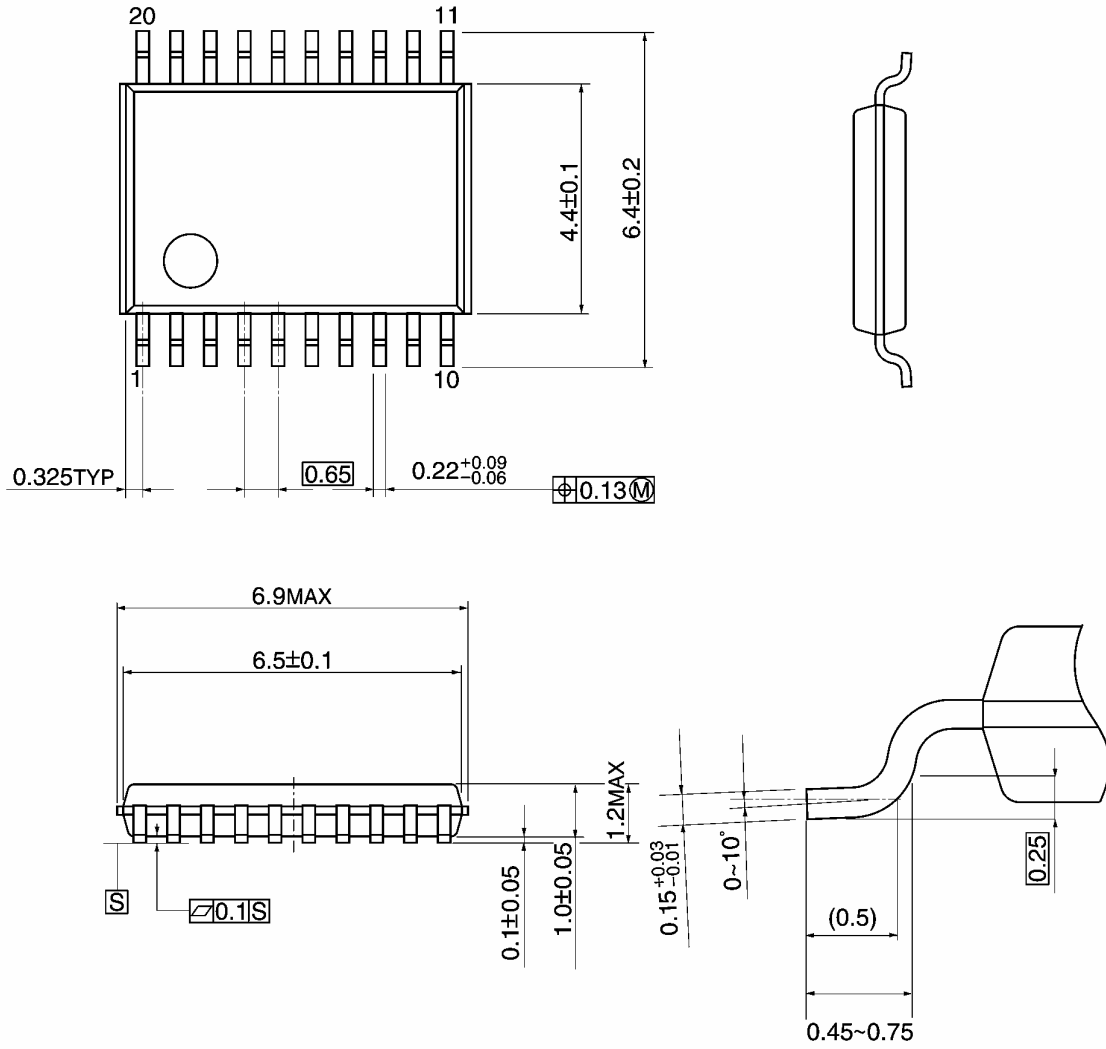

Weight: 0.08 g (typ.)



## Package Dimensions

VSSOP20-P-0030-0.50

Unit: mm

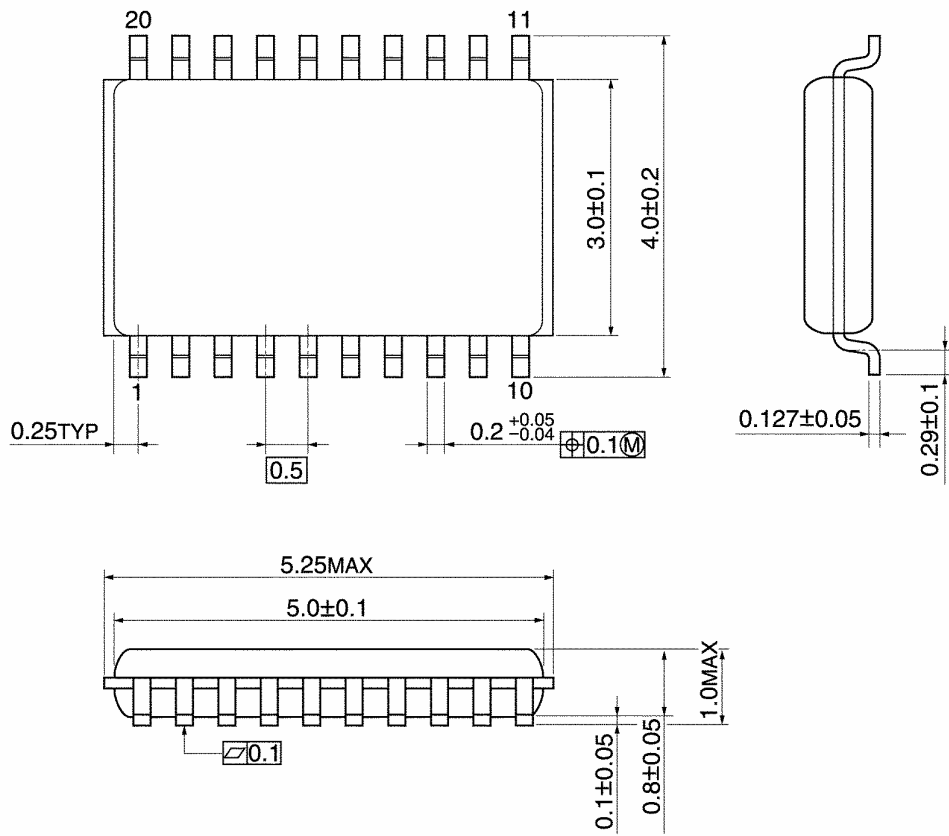

Weight: 0.03 g (typ.)

**RESTRICTIONS ON PRODUCT USE**

20070701-EN

- The information contained herein is subject to change without notice.
- TOSHIBA is continually working to improve the quality and reliability of its products. Nevertheless, semiconductor devices in general can malfunction or fail due to their inherent electrical sensitivity and vulnerability to physical stress. It is the responsibility of the buyer, when utilizing TOSHIBA products, to comply with the standards of safety in making a safe design for the entire system, and to avoid situations in which a malfunction or failure of such TOSHIBA products could cause loss of human life, bodily injury or damage to property.  
In developing your designs, please ensure that TOSHIBA products are used within specified operating ranges as set forth in the most recent TOSHIBA products specifications. Also, please keep in mind the precautions and conditions set forth in the "Handling Guide for Semiconductor Devices," or "TOSHIBA Semiconductor Reliability Handbook" etc.
- The TOSHIBA products listed in this document are intended for usage in general electronics applications (computer, personal equipment, office equipment, measuring equipment, industrial robotics, domestic appliances, etc.). These TOSHIBA products are neither intended nor warranted for usage in equipment that requires extraordinarily high quality and/or reliability or a malfunction or failure of which may cause loss of human life or bodily injury ("Unintended Usage"). Unintended Usage include atomic energy control instruments, airplane or spaceship instruments, transportation instruments, traffic signal instruments, combustion control instruments, medical instruments, all types of safety devices, etc.. Unintended Usage of TOSHIBA products listed in his document shall be made at the customer's own risk.
- The products described in this document shall not be used or embedded to any downstream products of which manufacture, use and/or sale are prohibited under any applicable laws and regulations.
- Please contact your sales representative for product-by-product details in this document regarding RoHS compatibility. Please use these products in this document in compliance with all applicable laws and regulations that regulate the inclusion or use of controlled substances. Toshiba assumes no liability for damage or losses occurring as a result of noncompliance with applicable laws and regulations.