

SBC

PSB-602LF

Socket 775 New Intel® Q965, supports Intel® Core 2 Duo Processors for Best in Class Performance

Features and Benefits:

- PICMG 1.0 Full size CPU card, supports Intel® Core 2 Duo, Intel® Celeron® D, Intel® Pentium® D and Intel® Pentium® 4 processors
- Equipped with Intel® Q965 Chipset with FSB 1066MHz
- Memory supports DDRII 800 SDRAM up to 4GB
- Applications such as gaming, medical, multimedia systems, digital image storage servers and more



No. 24, Lane 365, Yang Guang St., Nei Hu District, Taipei 114, Taiwan

Tel: +886-2-8751-1111

Fax: +886-2-8751-1199

Email: sales@protech.com.tw

<http://www.protech.com.tw>



ISO CERTIFIED
9001 14001

PSB-602LF

Socket 775 New Intel® Q965 Supports Intel® Core 2 Duo Processors for Best in Class Performance

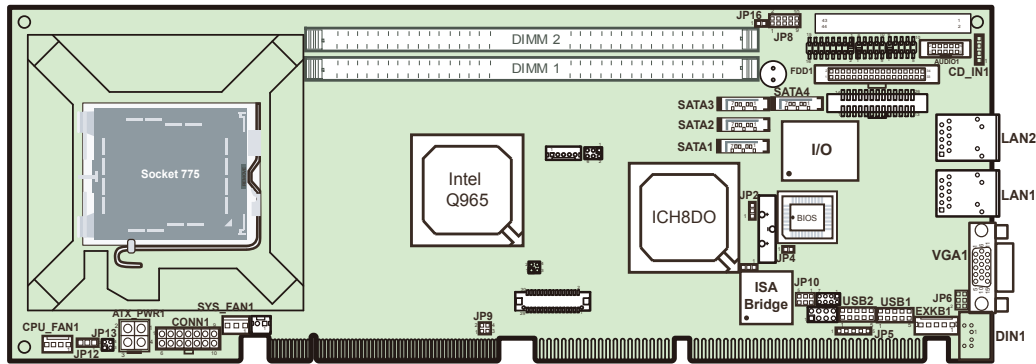

Specifications

System

CPU Type	Intel® Celeron® D, Pentium® 4, Pentium® D, Core 2 Duo, LGA-775 processor
Chipset	Intel® Q965 + ICH8DO + FWH (FSB : 533/800/1066MHz)
DRAM	2 x 240-Pin DDR2-DIMM Socket (Supports DDR2 533/667/800MHz, up to 4GB)
BIOS	PhoenixAward PnP BIOS, with VGA BIOS
Watchdog	1~255 secs Watchdog timer selectable w / Reset / NMI
Power Supply	Supports ATX / AT Power
Power Requirement	+5V, +12V
Power Consumption	+5V : 3.2A / +12V : 10.45A
Dimension	338.5mm x 122mm (13.33" x 4.8")

I/O Chipset

SATA Interface	4 x S-ATA connector
FDD Interface	1 x FDD connector with 34-pin Boxheader on board
IDE Interface	1 x 40-pin IDE (UDMA33/66/100)
Function BUS	1 x CF
Serial Port	2 x Serial ports, 16550 UARTs RS-232 x COM 1 for RS-232, COM 2 for RS-232/422/485
Parallel Port	1 x Parallel Port (SPP/EPP/ECP)
IrDA	1 (SIR)

Keyboard

Mini DIN connector

Mouse

Mini DIN connector

LAN

Lan1 : Marvell 88E8052, 1G BaseTx Ethernet
Lan2 : Marvell 88E8052, 1G BaseTx Ethernet

Audio

Realtek ALC262 with Line-in / Line-out / MIC

USB

4 x USB 2.0

Display

Graphic

Built-in Intel® Q965, share system memory, Supports CRT, LVDS (LVDS transfer from SDVO)

Environment

OperationTemp. 0°~60°C(32°~140°F)

Storage Temp. -40°~85°C(-40°~185°F)

Humidity Operation humidity 20~90%,
Storage humidity 20~95%

Ordering Information

PSB-602LF PICMG 1.0 Intel® Core S775 Q965 w VGA / Audio / 2 x COM / 2 x LAN (1Gmpbs)

Certificate: CE, FCC, CLASS A

All of trademarks and brand names are the property of their owners. Trademark "Protech" is the property of Protech Systems Co., Ltd. All information contained in this document is subject to change without any prior notice. This catalog is copyrighted in Feb. 2009.