

---

## Low-Voltage, Voice-Switched Circuit for Hands-Free Operation

---

### Description

The low-voltage, voice-switched speakerphone circuit U4084B incorporates the features listed below. The versatility of the device is further enhanced by giving access to internal circuit points.

The block diagram shows amplifiers, level detectors, transmit and receive attenuators operating in complementary functions, back ground noise monitors, chip

disable, dial tone detector and mute function etc.

Due to low-voltage operation, it can be operated either by low supply voltage or via a telephone line requiring 4.0 mA typ. Further features are stand-alone operation via a coupling transformer (Tip and Ring) or in conjunction with a handset speech network, as shown in figure 2.

### Features

- Low-voltage operation: 3.0 to 6.5 V
- Attenuator gain range between transmit and receive: 52 dB
- Four-point signal sensing for improved sensitivity
- Monitoring system for background-noise level
- Microphone-amplifier gain adjustable
- Mute function
- Chip disable for active/ standby operation
- Dial tone detector
- Compatible with the speaker amplifier U4083B
- Case: DIP24 or SO24

### Benefits

- Fast channel switching enables quasi duplex operation
- Low current consumption for high output volume
- Optimized U3800BM interface

## Block Diagram

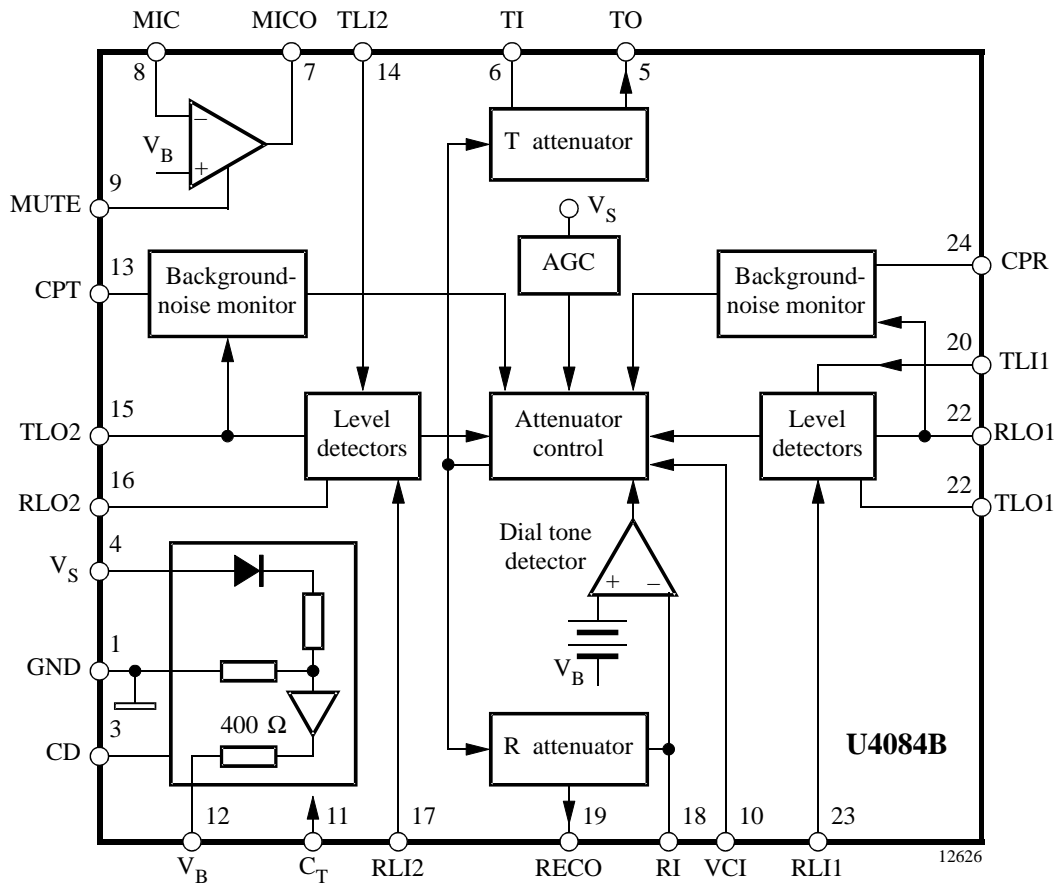

Figure 1. Block diagram

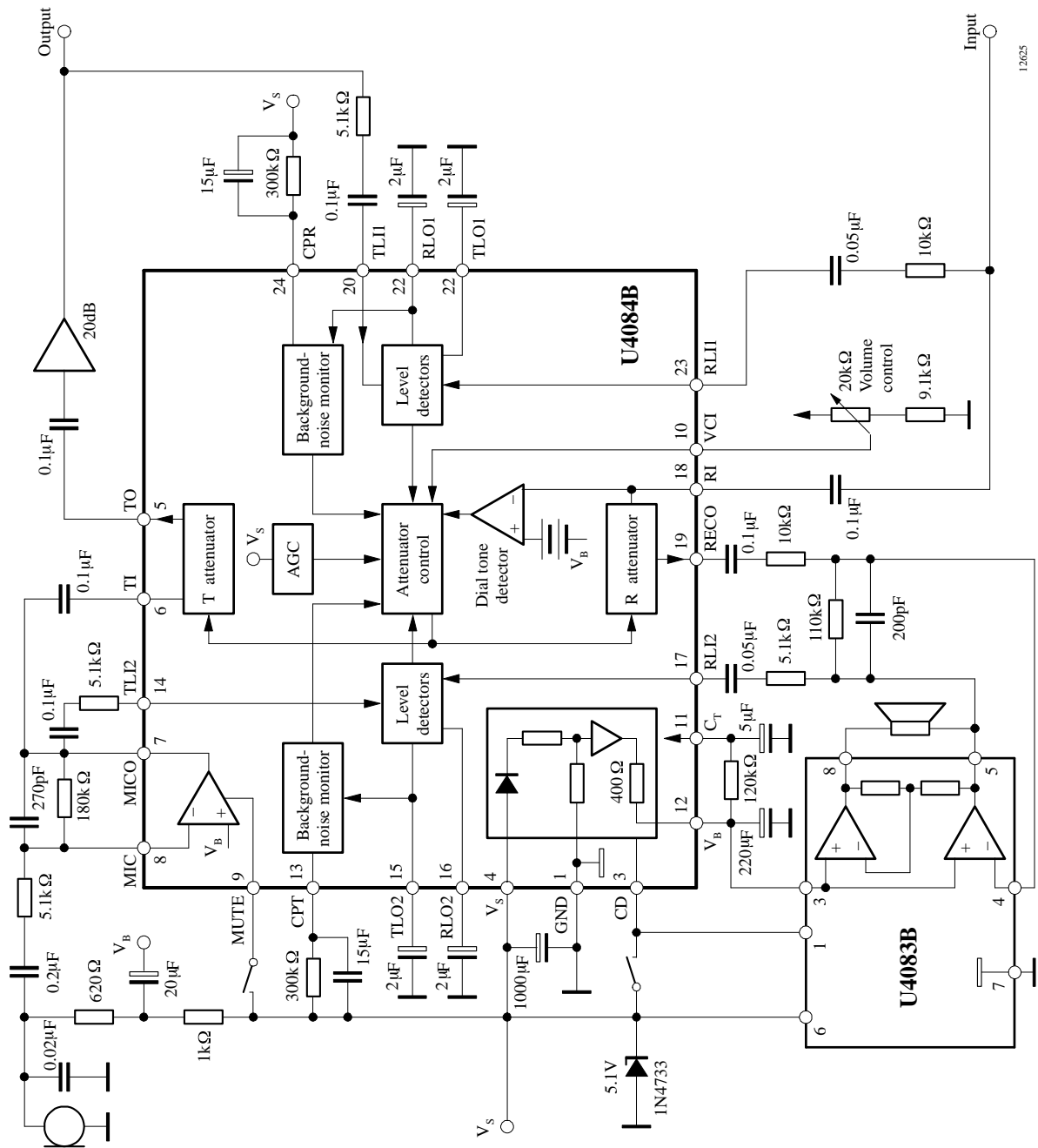

Figure 2. Block diagram with external circuit

## Pin Description

Pin	Symbol	Function
1	GND	Ground
2	NC	Not connected
3	CD	Chip disable. A logic LOW (< 0.8 V) sets normal operation. A logic HIGH (> 2.0 V) disables the IC to conserve power. The input impedance is nominally 90 k $\Omega$ .
4	V <sub>S</sub>	Supply voltage 2.8 to 6.5 V, approximately @ 4 mA. The AGC circuit reduces the receive attenuator gain @ 25 dB. Receive mode @ 2.8 V.
5	TO	Transmit attenuator output. The DC level is approximately V <sub>B</sub> .
6	TI	Transmit attenuator input. Max. signal level is 350 mV <sub>rms</sub> . The input impedance is approximately 10 k $\Omega$ .
7	MICO	Microphone amplifier output. The gain is set by external resistors.
8	MIC	Microphone amplifier input. The bias voltage is approximately V <sub>B</sub> .
9	MUTE	Mute input. A logic LOW (< 0.8 V) sets normal operation. A logic HIGH (> 2.0 V) mutes the microphone amplifier without affecting the rest of the circuit. The input impedance is nominally 90 k $\Omega$ .
10	VCI	Volume control input. When VCI = V <sub>B</sub> , the receive attenuator is at maximum gain in the receive mode. When VCI = 0.3 V <sub>B</sub> , the receive gain is 35 dB lower. This does not affect the transmit mode.

Pin	Symbol	Function
11	C <sub>T</sub>	Response time. An RC at this pin sets the response time for the circuit to switch modes.
12	V <sub>B</sub>	Output voltage $\approx V_S/2$ . It is a system AC ground, and biases the volume control. A filter cap is required.
13	CPT	An RC at this pin sets the time constant for the transmit background monitor.
14	TLI2	Transmit-level detector input on the microphone/ speaker side.
15	TLO2	Transmit-level detector output on the microphone/ speaker side, and input to the transmit background monitor.
16	RLO2	Receive-level detector output on the microphone/ speaker side
17	RLI2	Receive-level detector input on the microphone/ speaker side
18	RI	Input receive attenuator and dial-tone detector. The max. input level is 350 mV <sub>rms</sub> . The input impedance is approximately 10 k $\Omega$ .
19	RECO	Receive attenuator output. DC level is approximately V <sub>B</sub> .
20	TLI1	Transmit-level detector input on the line side
21	TLO1	Transmit-level detector output on the line side
22	RLO1	Receive-level detector output on the line side, and input to the receive background monitor
23	RLI1	Receive-level detector input on the line side
24	CPR	An RC at this pin sets the time constant for the receive background monitor

## Absolute Maximum Ratings

Reference point Pin 1,  $T_{amb} = 25^{\circ}\text{C}$ , unless otherwise specified.

Parameters		Symbol	Value	Unit
Supply voltage	Pin 4	$V_S$	-1.0 to +7.0	V
Voltages	Pins 3 and 9		-1.0 to ( $V_S + 1.0$ )	V
	Pin 10		-1.0 to ( $V_S + 0.5$ )	
	Pins 6 and 18		-0.5 to ( $V_S + 0.5$ )	
Storage temperature range		$T_{stg}$	-55 to +150	$^{\circ}\text{C}$
Junction temperature		$T_j$	125	$^{\circ}\text{C}$
Ambient temperature range		$T_{amb}$	-20 to +60	$^{\circ}\text{C}$
Power dissipation $T_{amb} = 60^{\circ}\text{C}$	DIP24	$P_{tot}$	650	mW
	SO24	$P_{tot}$	520	

## Maximum Thermal Resistance

Parameters		Symbol	Value	Unit
Junction ambient	DIP24	$R_{thJA}$	100	K/W
	SO24	$R_{thJA}$	120	K/W

## Operation Recommendation

Parameters	Test Conditions / Pins	Symbol	Min.	Typ.	Max.	Unit
Supply voltage	Pin 4	$V_S$	3.5	-	6.5	V
CD input	Pin 3		0	-	$V_S$	V
MUTE input	Pin 9					
Output current	Pin 12	$I_B$	-	-	500	$\mu\text{A}$
Volume control input	Pin 10	VCI	$0.3 \times V_B$	-	$V_B$	V
Attenuator input signal voltage	Pins 6 and 18		0	-	350	$\text{mV}_{rms}$
Microphone amplifier			0	-	40	dB
Load current	@ RECO, TO Pins 5, 19		0	-	$\pm 2.0$	mA
	@ MICO Pin 7		0	-	$\pm 1.0$	
Ambient temperature range		$T_{amb}$	-20	-	+60	$^{\circ}\text{C}$

## Electrical Characteristics

$T_{amb} = +25^{\circ}\text{C}$ ,  $V_S = 5.0\text{ V}$ ,  $CD \leq 0.8\text{ V}$ , unless otherwise specified

Parameters	Test Conditions / Pins	Symbol	Min.	Typ.	Max.	Unit
<b>Power supply</b>						
Supply current	$V_S = 6.5\text{ V}$ , $CD = 0.8\text{ V}$ $V_S = 6.5\text{ V}$ , $CD = 2.0\text{ V}$	$I_S$		4.0 600.0	6.0 800.0	mA $\mu\text{A}$
CD input resistance	$V_S = V_{CD} = 6.5\text{ V}$	$R_{CD}$	50.0	90.0		$\text{k}\Omega$
CD input voltage	– High – Low	$V_{CDH}$ $V_{CDL}$	2.0 0.0		$V_S$ 0.8	V
Output voltage	$V_S = 3.5\text{ V}$ $V_S = 5.0\text{ V}$	$V_B$	1.8	1.3 2.1	2.4	V
Output resistance	$I_{VB} = 1.0\text{ mA}$	$R_{OVb}$		400.0		$\Omega$
Power supply rejection ratio	$C_{VB} = 220\text{ }\mu\text{F}$ , $f = 1.0\text{ kHz}$	PSRR		54.0		dB
<b>Attenuators</b>						
Receive attenuator gain	$f = 1.0\text{ kHz}$ , $V_{CI} = V_B$ R mode, $RI = 150\text{ mV}_{rms}$ ( $V_S = 5.0\text{ V}$ ) R mode, $RI = 150\text{ mV}_{rms}$ ( $V_S = 3.5\text{ V}$ )	$G_R$	4.0	6.0	8.0	dB
Gain change	$V_S = 3.5\text{ V}$ vs. $V_S = 5.0\text{ V}$	$\Delta G_{R1}$	-0.5	0.0	+0.5	
AGC gain change	$-V_S = 2.8\text{ V}$ vs. $V_S = 5.0\text{ V}$	$\Delta G_{R2}$		-25.0	-15.0	
Idle mode	$RI = 150\text{ mV}_{rms}$	$G_{RI}$	-22.0	-20.0	-17.0	dB
Range R to T mode		$\Delta G_{R3}$	49.0	52.0	54.0	
Volume control range	R mode, $0.3 V_B < V_{CI} < V_B$	$V_{CR}$	27.0	35.0		dB
RECO DC voltage	R mode	$V_{RECO}$		$V_B$		V
RECO DC voltage	R to T mode	$\Delta V_{RECO}$		$\pm 10$	$\pm 150.0$	mV
RECO high voltage	$I_O = 1.0\text{ mA}$ $RI = V_B + 1.5\text{ V}$	$V_{RECOH}$	3.7			V
RECO low voltage	$I_O = 1.0\text{ mA}$ $RI = V_B - 1.0\text{ V}$ , output measured w.r.t. $V_B$	$V_{RECOL}$		-1.5	-1.0	V
RI input resistance	$RI < 350\text{ mV}_{rms}$	$R_{RI}$	7.0	10.0	14.0	$\text{k}\Omega$
Transmit attenuator gain	$f = 1.0\text{ kHz}$ T mode, $TI = 150\text{ mV}_{rms}$ Idle mode, $TI = 150\text{ mV}_{rms}$ Range T to R mode	$G_T$ $G_{TI}$ $G_{TI}$	4.0 -22.0 49.0	6.0 -20.0 52.0	8.0 -17.0 54.0	dB
TO DC voltage	T mode	$V_{TO}$		$V_B$		V
TO DC voltage	T to R mode	$V_{TO}$		$\pm 100$	$\pm 150.0$	mV
TO high voltage	$I_O = -1.0\text{ mA}$ $TI = V_B + 1.5\text{ V}$	$V_{TOH}$	3.7			V
TO low voltage	$I_O = +1.0\text{ mA}$ $TI = V_B - 1.0\text{ V}$ , output measured w.r.t. $V_B$	$V_{TOL}$		-1.5	-1.0	V
TI input resistance	$TI < 350\text{ mV}_{rms}$	$R_{TI}$	7.0	10.0	14.0	$\text{k}\Omega$
Gain tracking	$G_R + G_T$ , @ T, Idle, R	$G_{TR}$		$\pm 0.5$		dB

Parameters	Test Conditions / Pins	Symbol	Min.	Typ.	Max.	Unit
<b>Attenuator control</b>						
$C_T$ voltage	Pin 14 – $V_B$ R mode, $V_{CI} = V_B$ Idle mode T mode	$V_{CT}$		240.0 0.0 –240.0		mV
$C_T$ source current	R mode	$I_{CTR}$	–85.0	–60.0	–40.0	$\mu A$
$C_T$ sink current	T mode	$I_{CTT}$	40.0	60.0	85.0	$\mu A$
$C_T$ slow idle current		$I_{CTS}$		0.0		$\mu A$
$C_T$ fast idle internal resistance		$R_{FI}$	1.5	2.0	3.6	k $\Omega$
VCI input current		$I_{VCI}$		–60.0		nA
Dial tone detector threshold		$V_{DT}$	10.0	15.0	20.0	mV
<b>Microphone amplifier <math>V_{MUTE} &lt; 0.8</math> V, <math>G_{VCL} = 31</math> dB</b>						
Output offset	$V_{MICO} - V_B$ , Feedback R = 180 k $\Omega$	$MICO_{vos}$	–50.0	0.0	+50.0	mV
Open loop gain	$f < 100$ Hz	$G_{VOLM}$	70.0	80.0		dB
Gain bandwidth		$GBW_M$		1.0		MHz
Output high voltage	$I_O = -1.0$ mA, $V_S = 5.0$ V	$V_{MICOH}$	3.7			V
Output low voltage	$I_O = +1.0$ mA	$V_{MICOL}$			200.0	mV
Input bias current (MIC)		$I_{BM}$		–40.0		nA
Muting ( $\Delta$ gain)	$f = 1.0$ kHz, $V_{MUTE} = 2.0$ V $300$ Hz $< f < 10$ kHz	G G	–55.0	–68.0		dB dB
MUTE input resistance	$V_S = V_{MUTE} = 6.5$ V	$R_{MUTE}$	50.0	90.0		k $\Omega$
MUTE input high		$V_{MUTEH}$	2.0		$V_S$	V
MUTE input low		$V_{MUTEL}$	0.0		0.8	V
Distortion	$300$ Hz $< f < 10$ kHz	$THD_M$		0.15		%
<b>Level detectors and background-noise monitors</b>						
Transmit receive switching threshold	Ratio of current at RLI1 + RLI2 to 20 $\mu A$ at TLI1 + TLI2 to switch from T to R	$I_{TH}$	0.8	1.0	1.2	
Source current	at RLO1, RLO2, TLO1, TLO2	$I_{LSO}$		–2.0		mA
Sink current	at RLO1, RLO2, TLO1, TLO2	$I_{LSK}$		4.0		$\mu A$
CPR, CPT output resistance	$I_O = 1.2$ mA	$R_{CP}$		150		$\Omega$
CPR, CPT leakage current		$I_{CCLK}$		–0.2		$\mu A$
<b>System distortion</b>						
R mode	From RI to RECO	$d_R$		0.5	3.0	%
T mode	From MIC to TO includes T attenuator	$d_T$		0.8	3.0	%

## Temperature Characteristics

Parameter	Typical Value @ 25°C	Typical Change -20 to +60°C
Supply current, CD = 0.8 V    I <sub>S</sub>	4.0 mA	-0.3%/°C
Supply current, CD = 2.0 V    I <sub>S</sub>	400.0 μA	-0.4%/°C
V <sub>B</sub> output voltage, V <sub>S</sub> = 5.0 V    V <sub>O</sub>	2.1 V	+0.8%/°C
Attenuator gain (max. gain)	+6.0 dB	0.0008 dB/°C
Attenuator gain (max. attenuation)	-46.0 dB	0.004 dB/°C
Attenuator input resistance (@ TI, RI)	10.0 kΩ	+0.6%/°C
Dial-tone detector threshold	15.0 mV	+20.0 μV/°C
CT source, sink current	± 60.0 μA	-0.15%/°C
Microphone, hybrid offset	0.0 mV	± 4.0 μV/°C
Transmit receive switching threshold	1.0	± 0.02%/°C
Sink current at RLO1, RLO2, TLO1, TLO2	4.0 μA	- 10.0 nA/°C



## Introduction

### General

The fundamental difference between the operation of a speakerphone and a handset is that of half-duplex versus full-duplex. The handset is full-duplex since conversation can occur in both directions (transmit and receive) simultaneously. A speakerphone has higher gain levels in both paths, and attempting to converse full-duplex results in oscillatory problems due to the loop that exists within the system. The loop is formed by the receive and transmit paths, the hybrid and the acoustic coupling (speaker to microphone).

Today, the only practical and economical solution is to design the speakerphone in half-duplex mode, i.e., only one person speaks at a time, while the other listens. To achieve this, a circuit able to detect who is talking, to switch-on the appropriate path (transmit or receive) and to switch-off (attenuate) the other path is necessary. In this way, the loop gain is maintained less than unity. The circuit has to detect quickly a change from one speaker to the other and to switch the circuit accordingly. Due to its speech-level detectors, the circuit operates in a "hands-free" mode, eliminating the need for a "push-to-talk" switch.

The handset has the same loop as the speakerphone. Oscillations do not occur because the gains are considerably lower, and there is almost no coupling from the earpiece to the mouthpiece (the receiver is normally held at a person's ear).

The U4084B provides the level detectors, attenuators, and switching control necessary for proper operation of the speakerphone. The detection sensitivity and timing are externally controllable. Additionally, the U4084B provides background-noise monitors which make the circuit insensitive to room and line noise, hybrid amplifiers for interfacing to tip and ring, the microphone amplifier, and other associated functions.

### Transmit and Receive Attenuators TI, TO and RI, RECO

The attenuators are operating complementary, i.e., when one is at maximum gain (+6.0 dB), the other is at maximum attenuation (-46 dB), and vice versa, i.e., both are never completely on or off. The sum of their gains remains constant (within a nominal error band of  $\pm 0.5$  dB) at a typical value of -40 dB (see figure 8). The attenuators control the transmit and receive paths to provide the half-duplex operation required in a speakerphone.

The attenuators are non-inverting, and have a -3.0 dB (from max. gain) frequency of approximately 100 kHz. The input impedance of each attenuator (TI and RI) is nominally 10 k $\Omega$  (see figure 3). To prevent distortion the input signal should be limited to 350 mV<sub>rms</sub>. The maximum recommended input signal is independent from the volume control setting. The diode clamp on the inputs limits the input swing, and therefore the maximum negative output swing. The output impedance is less than 10  $\Omega$  until the output current limit (typically 2.5 mA) is reached.

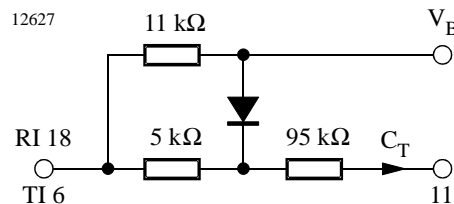

Figure 3. Attenuator input stage

The attenuators are controlled by the signal output of the control block which is measurable at the C<sub>T</sub> pin (Pin 11). When the C<sub>T</sub> pin is at +240 mV w.r.t. V<sub>B</sub>, the circuit is in receive mode (the receive attenuator is at 6.0 dB). When the C<sub>T</sub> pin is at -240 mV w.r.t. V<sub>B</sub>, the circuit is in transmit mode (the transmit attenuator is at 6.0 dB). The circuit is in idle mode when the C<sub>T</sub> voltage is equal to V<sub>B</sub> causing the attenuators' gain to be half-way between their fully-on and fully-off position (-20 dB each). Monitoring the C<sub>T</sub> voltage (w.r.t. V<sub>B</sub>) is the most direct method of monitoring the circuit's mode.

The attenuator control has seven inputs: two from the comparators operated by the level detectors, two from the background noise monitors, volume control, dial-tone detector, and AGC. They are described as follows:

## Level Detectors, Figure 4

There are four level detectors, two on the receive side and two on the transmit side. As shown in figure 4, the terms in parentheses form one system, and the other terms form the second system. Each level detector is a high-gain amplifier with back-to-back diodes in the feedback path, resulting in a non-linear gain which permits operation over a wide dynamic range of speech levels. Refer to figures 9, 10 and 11 for their AC and DC transfer characteristics. The sensitivity of each level detector is determined by the external resistor and capacitor at each input (TLI1, TLI2, RLI1, and RLI2). Each output charges an external capacitor through a diode and limiting resistor, thus providing a DC representation of the input AC signal level. The outputs have a quick rise time (determined by the capacitor and an internal 350-Ω resistor), and a slow decay time set by an internal current source and the capacitor. The capacitors on the four outputs should have the same value ( $\pm 10\%$ ) to prevent timing problems.

On the receive side, one level detector (RLI1) is at the receive input receiving the same signal as at tip and ring, and the other (RLI2) is at the output of the speaker amplifier (see figure 2). On the transmit side, one level detector (TLI2) is at the output of the microphone amplifier while the other (TLI1) is at the hybrid output. Outputs RLO1 and TLO1 feed a comparator. The output of this compa-

rator goes to the attenuator control block. Likewise, outputs RLO2 and TLO2 feed a second comparator which also goes to the attenuator control block. The truth table for the effects of the level detectors is given in the section "Attenuator Control Block".

## Background-Noise Monitors

The background-noise monitors distinguish speech (which consists of bursts) from background noise (a relatively constant signal level). There are two background-noise monitors – one for the receive path and the other for the transmit path. Referring to figure 4, the receive background-noise monitor is operated by the TLI2–TLO2 level detector.

Background-noise monitoring is carried out by storing a DC voltage representative of the respective noise levels in capacitors at CPR and CPT. The voltages at these pins have slow rise times (determined by the external RC), but fast decay times. If the signal at RLI1 (or TLI2) changes slowly, the voltage at CPR (or CPT) will remain being more positive than the voltage at the non-inverting input of the monitor's output comparator. When speech is present, the voltage on the non-inverting input of the comparator will rise quicker than the voltage at the inverting input (due to the burst characteristic of speech), causing its output to change. This output is sensed by the attenuator control block".

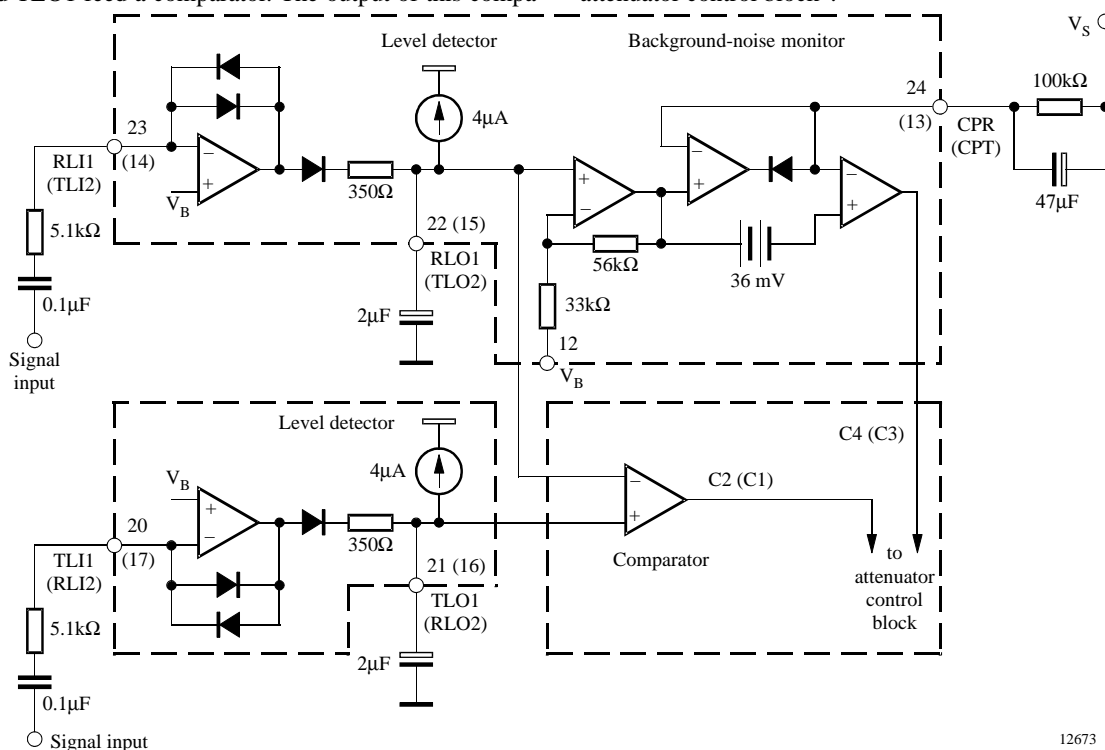

Figure 4. Level detectors

12673

The 36-mV offset at the comparator's input keeps the comparator from changing state unless the speech level exceeds the background noise by approximately 4.0 dB. The time constant of the external RC (approximately 4.5 s) determines the response time to background-noise variations.

## Volume Control

The volume control input at VCI (Pin 10) is sensed as a voltage w.r.t.  $V_B$ . It affects the attenuators only in receive mode and has no effect in the idle or transmit modes.

In receive mode, the receive attenuator gain,  $G_R$ , is 6.0 dB, and the transmit attenuator gain,  $G_T$ , is -46 dB under the condition that  $VCI = V_B$ . When  $VCI < V_B$ , the receive attenuator gain is reduced (figure 10), whereas the transmit attenuator gain is increased. Their sum, however, remains constant. A voltage deviation at VCI changes the voltage at  $C_T$ , which in turn controls the attenuators (see "Attenuator Control Block").

The volume control setting does not affect the maximum attenuator input signal at which noticeable distortion occurs.

The bias current at VCI is typically -60 nA. It does not vary significantly with the VCI voltage or supply voltage  $V_S$ .

## Dial-Tone Detector

The dial-tone detector is a comparator with one side connected to the receive input (RI) and the other to  $V_B$  with a 15-mV offset (see figure 5). If the circuit is in idle mode, and the incoming signal is greater than 15 mV (10 mV<sub>rms</sub>), the comparator's output will change, disabling the receive idle mode. The receive attenuator will then be at a setting determined mainly by the volume control.

This circuit prevents the dial tone (which would be considered as continuous noise) from fading away as the circuit would have the tendency to switch to the idle mode. By disabling receive idle mode, the dial tone remains at the normally expected full level.

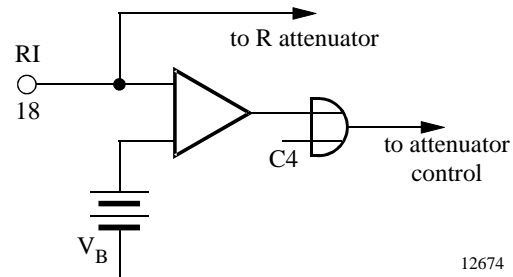

Figure 5. Dial-tone detector

## AGC

The AGC circuit affects the circuit only in receive mode, and only when the supply voltage is less than 3.5 V. As  $V_S < 3.5$  V, the gain of the receive attenuator is reduced (see figure 13). The transmit path attenuation changes such that the sum of the transmit and receive gains remains constant.

The purpose of this feature is to reduce the power (and the current) used by the speaker when a line-powered speakerphone is connected to a long line where the available power is limited. By reducing the speaker power, the voltage sag at  $V_S$  is controlled, preventing possible erratic operation.

## Attenuator Control Block

The attenuator control block has seven inputs:

- The output of the comparator operated by RLO2 and TLO2 (microphone/speaker side) – designated C1
- The output of the comparator operated by RLO1 and TLO1 (Tip/Ring side) – designated C2
- The output of the transmit background-noise monitor – designated C3
- The output of the receive background-noise monitor – designated C4
- The volume control
- The dial-tone detector
- The AGC circuit

The single output of the control block controls the two attenuators. The effect of C1–C4 is as follows:

Inputs				Output
C1	C2	C3	C4	Mode
T	T	1	X	Transmit
T	R	Y	Y	Fast idle
R	T	Y	Y	Fast idle
R	R	X	1	Receive
T	T	0	X	Slow idle
T	R	0	0	Slow idle
R	T	0	0	Slow idle
R	R	X	0	Slow idle

X = don't care; Y = C3 and C4 are not both 0.

## Terms Definition

11. "Transmit" means the transmit attenuator is fully on (+ 6.0 dB), and the receive attenuator is at max. attenuation (– 46 dB).
12. "Receive" means both attenuators are controlled by the volume control. At max. volume, the receive attenuator is fully on (+ 6.0 dB), and the transmit attenuator is at max. attenuation (– 46 dB).
13. "Fast Idle" means both transmit and receive speech are present in approximately equal levels. The attenuators are quickly switched (30 ms) to idle until one speech level dominates the other.
14. "Slow Idle" means speech has ceased in both transmit and receive paths. The attenuators are then slowly switched (1 s) to idle mode.
15. Switching to the full transmit of receive modes from any other mode is at the fast rate ( $\approx$  30 ms).

## Summary

1. The circuit will switch to transmit mode if:
  - a) both transmit level detectors sense higher signal levels relative to the respective receive level detectors (TLI1 versus RLI1, TLI2 versus RLI2), and

- b) the transmit background-noise monitor indicates the presence of speech

2. The circuit will switch to receive mode if:
  - a) both receive level detectors sense higher signal levels relative to the respective transmit level detectors, and
  - b) the receive background-noise monitor indicates the presence of speech
3. The circuit will switch to fast idle mode if the level detectors disagree on the relative strengths of the signal levels, and at least one of the background-noise monitors indicates speech. If, e.g., there is a signal at the microphone amp output (TLI2) to override the speaker signal (RLI2) and there is sufficient signal at the receive input (RLI1) to override the signal at the hybrid output (TLI1), and either one or both background monitors indicate speech, then the circuit switches to fast idle mode. Undesired switching to idle mode may occur if one of the following conditions is met:
  - a) when both persons speaking try to talk at the same time, and
  - b) when one of the persons speaking is in a very noisy environment, forcing the other one to continually override that noise level. In general, fast idle mode occurs rarely.
4. The circuit will switch to slow idle mode when
  - a) both persons at the phone are quiet (no speech present), or
  - b) when the speech level of one of the persons talking is continuously overridden by noise at the other speaker's location. The time required to switch the circuit between transmit, receive, fast idle and slow idle mode is determined in part by the components at Pin 11, (see the section "Switching Times" for a more detailed explanation). A schematic of the C<sub>T</sub> circuitry is shown in figure 6.

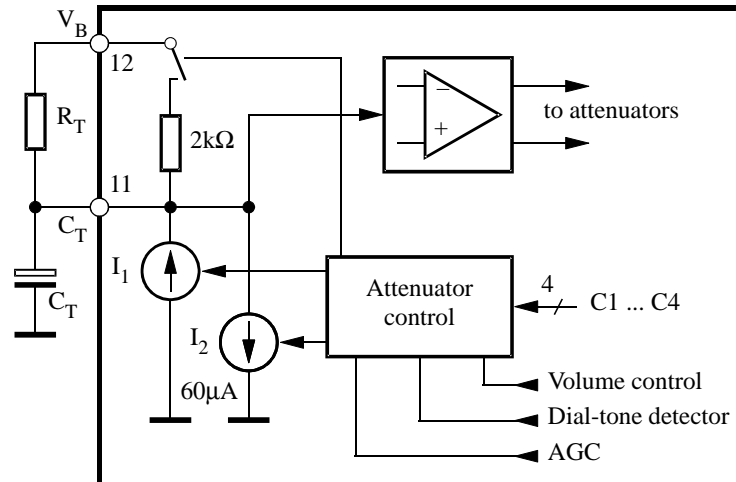

12675

Figure 6.  $C_T$  attenuator control block circuit

### Operation of the $C_T$ Circuitry

- $R_T$  is typ. 120 k $\Omega$  and  $C_T$  is typ. 5.0  $\mu$ F.
- To switch to receive mode,  $I_1$  is turned on ( $I_2$  is off), charging the external capacitor to + 240 mV above  $V_B$ . (An internal clamp prevents further charging of the capacitor).
- To switch to transmit mode,  $I_2$  is turned on ( $I_1$  is off) bringing down the voltage on the capacitor to - 240 mV with respect to  $V_B$ .
- To switch to idle mode quickly (fast idle), the current sources are turned off, and the internal 2.0-k $\Omega$  resistor is switched on, discharging the capacitor to  $V_B$  with a time constant = 2.0 k $\Omega$   $\times$   $C_T$ .
- To switch to idle slowly (slow idle), the current sources are turned off, the switch at the 2.0-k $\Omega$  resistor is open, and the capacitor discharges to  $V_B$  with a time constant =  $R_T$   $\times$   $C_T$ .

### Microphone Amplifier, Pins 7, 8 and 9

The non-inverting input of the microphone amplifier (Pins 7 and 8) is connected to  $V_B$ , while the inverting input and the output are pinned out.

Unlike most op amps, the amplifier has an all NPN output stage which maximizes phase margin and gain bandwidth. This feature ensures stability at gains less than unity, as well with a wide range of reactive loads.

The open loop gain is typically 80 dB ( $f < 100$  Hz), and the gain-bandwidth is typ. 1.0 MHz (see figure 4). The maximum p-p output swing is typ. ( $V_S - 1$  V) with an output impedance of  $< 10 \Omega$  until current limiting is reached (typ. 1.5 mA). The input bias current at MIC is typically - 40 nA.

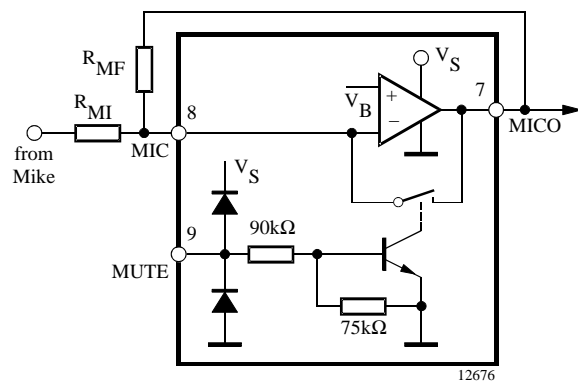

12676

Figure 7. Microphone amplifier and mute

When activated, the muting function (Pin 9) reduces the gain of the amplifier to approximately  $-39$  dB (with RMI =  $5.1$  k $\Omega$ ) by shorting the output to the inverting input (see figure 7). The mute input has a threshold of approximately  $1.5$  V, and the voltage at this pin must be kept within the range of ground and  $V_S$  (see figure 15). If the mute function is not used, the pin should be grounded.

## Power Supply, $V_B$ , and Chip Disable

The power supply voltage at Pin 4 ( $V_S$ ) is between  $3.5$  and  $6.5$  V for normal operation. Reduced operation at  $2.8$  V is, however, also possible (see figure 13 and the AGC section). The power supply current is shown in figure 16 for both operations, power-up and power-down mode.

The output voltage at  $V_B$  (Pin 12) is approximately  $(V_S - 0.7)/2$ , and provides the AC ground for the system. The output impedance at  $V_B$  is approximately  $400$   $\Omega$  (see figure 17), and forms – together with the external capacitor at  $V_B$  – a low-pass filter for power supply rejection. Figure 18 indicates the amount of rejection for different capacitors. The capacitor values depend on whether the circuit is powered by the telephone line or a power supply.

Since  $V_B$  biases the microphone amplifier, the amount of supply rejection at its output is directly related to the rejection at  $V_B$ , as well as its gain. Figure 19 depicts this graphically.

The chip disable (Pin 3) permits powering down the IC to conserve power and/or for muting purposes. With  $CD < 0.8$  V, normal operation is in effect.

With  $CD > 2.0$  V and  $< V_S$ , the IC is powered down. In the power-down mode, the microphone amplifier is disabled, and its output goes to a high impedance state. Additionally, the bias is removed from the level detectors.

The bias is not removed from the attenuators (Pins 5, 6, 18 and 19), or from Pins 10, 11 and 12 (the attenuators are disabled, however, and will not pass a signal). The input impedance at CD is typically  $90$  k $\Omega$  and has a threshold of approximately  $1.5$  V. The voltage at this pin must be kept within the range of ground and  $V_S$  (see figure 15). If CD is not used, the pin should be grounded.

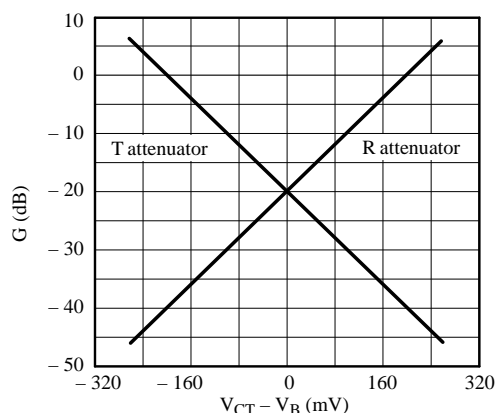

93 7767 e

Figure 8. Attenuator gain versus VCT (Pin 11)

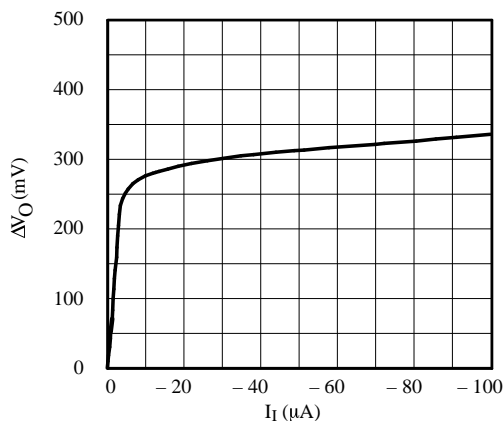

93 7768 e

Figure 9. Level-detector DC transfer characteristics

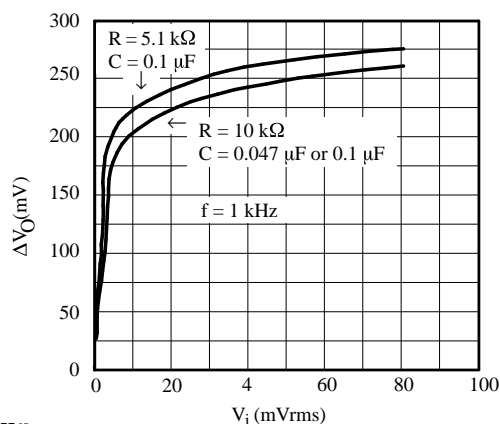

93 7769 e

Figure 10. Level-detector AC transfer characteristics

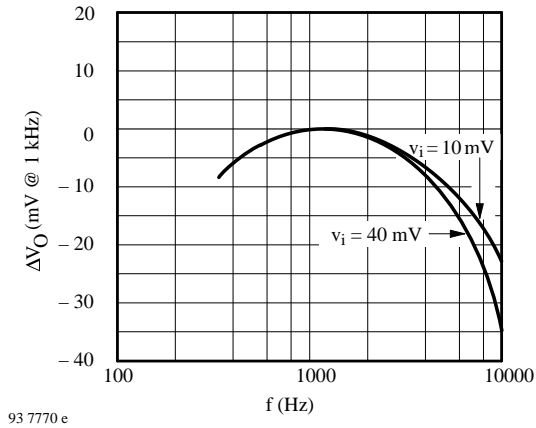

Figure 11. Level-detector AC transfer characteristics versus frequency

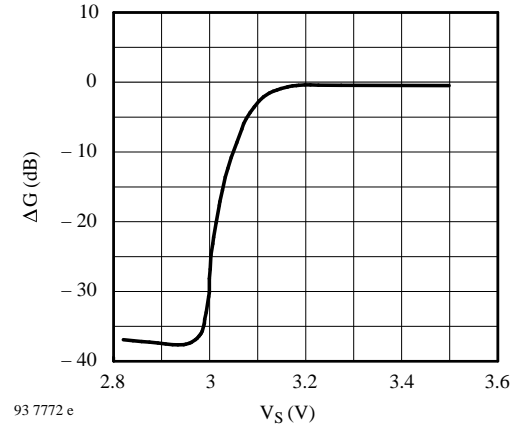

Figure 13. Receive attenuation gain versus  $V_S$

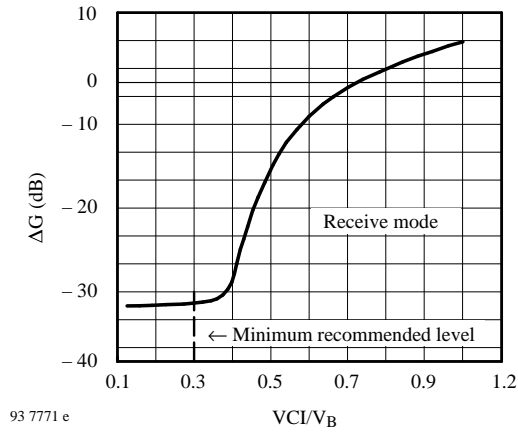

Figure 12. Receive attenuator versus volume control

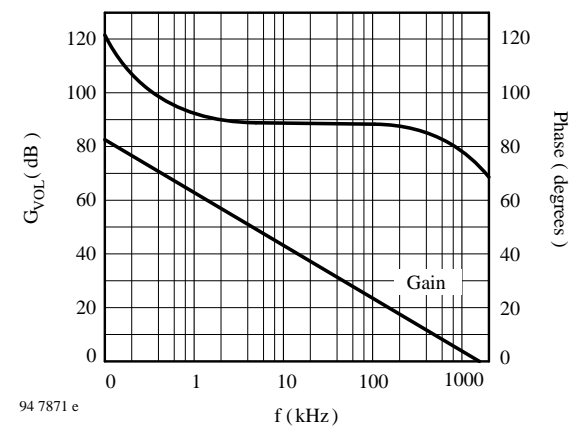

Figure 14. Microphone amplifier open loop gain and phase versus frequency

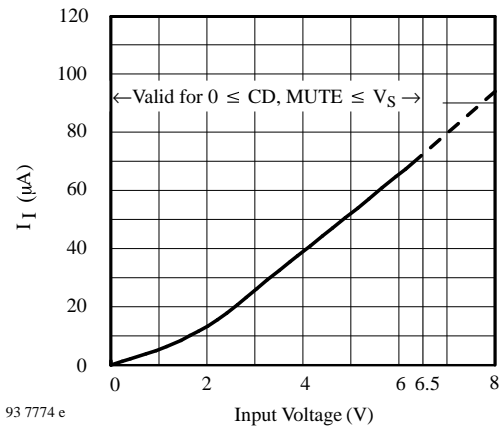

Figure 15. Input characteristics @ CD, MUTE

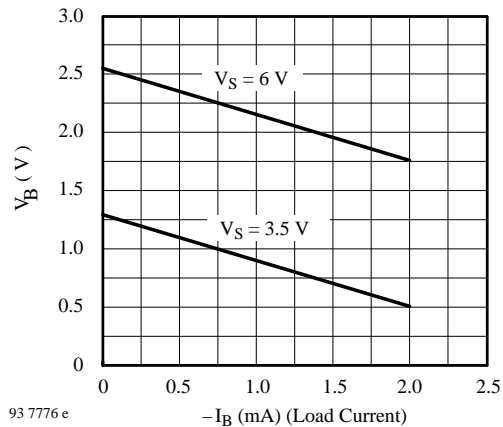

Figure 17.  $V_B$  output characteristics

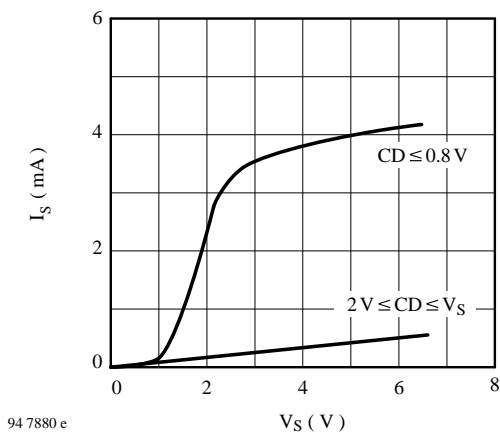

Figure 16. Supply current versus supply voltage

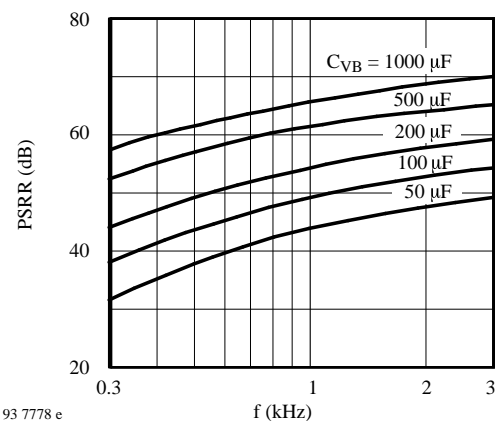

Figure 18.  $V_B$  power-supply rejection versus frequency characteristics and  $V_B$  capacitor



## Design Hints

### Switching Time, Figure 6

The switching time of the U4084B circuit is determined by  $C_T$  (Pin 11, refer to figure 6), and the capacitors at the level-detector outputs (RLO1, RLO2, TLO1, TLO2), see figure 2.

The switching time from idle to receive or transmit mode is determined by the capacitor at  $C_T$ , together with the internal current sources. The switching time is:

$$\begin{aligned}\Delta T &= \frac{\Delta V \times C_T}{I} \\ &= \frac{240 \times 5}{60} = 20.0 \text{ ms}\end{aligned}$$

where:

$$\begin{aligned}\Delta V &= 240 \text{ mV} \\ C_T &= 5 \mu\text{F} \\ I &= 60 \mu\text{A}\end{aligned}$$

If the circuit switches directly from receive to transmit mode (or vice-versa), the total switching time is 40 ms.

The switching time depends on the mode selection. If the circuit is switching to “fast idle”, the time constant is determined by the  $C_T$  capacitor, and the internal 2.0-k $\Omega$  resistor. With  $C_T = 5.0 \mu\text{F}$ , the time constant is approximately 10 ms, resulting in a switching time of approximately 30 ms (for 95% change). Fast idle is mode may occur if both persons are talking at the same time, thus trying to get control of the circuit. The switching time from idle back to either transmit or receive mode is described above.

By switching to “slow idle”, the time constant is determined by the  $C_T$  capacitor and  $R_T$ , the external resistor (see figure 6). With  $C_T = 5.0 \mu\text{F}$ , and  $R_T = 120 \text{ k}\Omega$ , the time constant is approximately 600 ms, resulting a switching time of approximately 1.8 seconds (for 95% change). The switching to slow idle starts when both speakers have stopped talking. The switching time back to the original mode depends on how fast that person starts talking again. The sooner the speaking starts during the 1.8-second period, the faster the switching time since a smaller voltage excursion is required. The switching time is determined by the internal current source as described above.

The above switching times occur after the level detectors have detected the appropriate signal levels, since their outputs operate the attenuator control block. The rise time

of the level detectors’ outputs to new speech is quick by comparison (approximately 1.0 ms), determined by the internal 350  $\Omega$  resistor and the external capacitor (typically 2.0  $\mu\text{F}$ ). The output’s decay time is determined by the external capacitor, and an internal 4.0- $\mu\text{A}$  current source giving a decay rate of 60 ms for a 120 mV excursion at RLO or TLO. The total response time of the circuit is not constant as it depends on the relative strength of the signals at the different level detectors and the timing of the signals with respect to each other. The capacitors at the four outputs (RLO1, RLO2, TLO1, TLO2) must have equal values ( $\pm 10\%$ ) to prevent problems in timing and level response.

The rise time of the level detector’s outputs is too short to be of significant. The decay time, however provides a significant part of the “hold time” necessary to hold the circuit during the normal pauses in speech.

The components at the inputs of the level detectors (RLI1, RLI2, TLI1, TLI2) do not affect the switching time but rather affect the relative signal levels required to switch the circuit and the frequency response of the detectors.

### Design Equations

Following definitions are used @ 1.0 kHz with reference to figures 2 and 21 whereas coupling capacitors are omitted for the sake of simplicity:

- $G_{MA}$  is the gain of the microphone amplifier measured from the microphone output to TI (typically 35 V/V, or 31 dB);
- $G_T$  is the gain of the transmit attenuator, measured from TI to TO;
- $G_{EXT}$  is the gain of an external transmit amplifier (typically 10.2 V/V, or 20.1 dB)
- $G_{ST}$  is the side-tone gain;
- $G_{EXR}$  is the gain of an external receive amplifier;
- $G_R$  is the gain of the receive attenuator measured from RI to RECO;
- $G_{SA}$  is the gain of the speaker amplifier, measured from RECO to the differential output of the speaker amplifier (typically 22 V/V or 26.8 dB);
- $G_{AC}$  is the acoustic coupling, measured from the speaker differential voltage to the microphone output voltage.

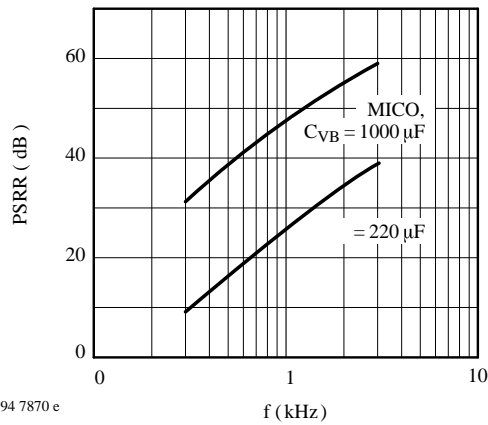

Figure 19. Power supply rejection of the microphone amplifier

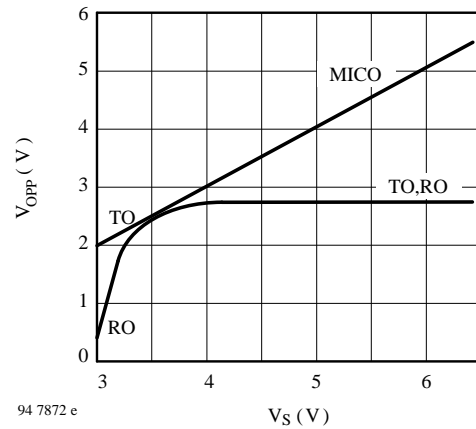

Figure 20. Typical output swing versus  $V_S$

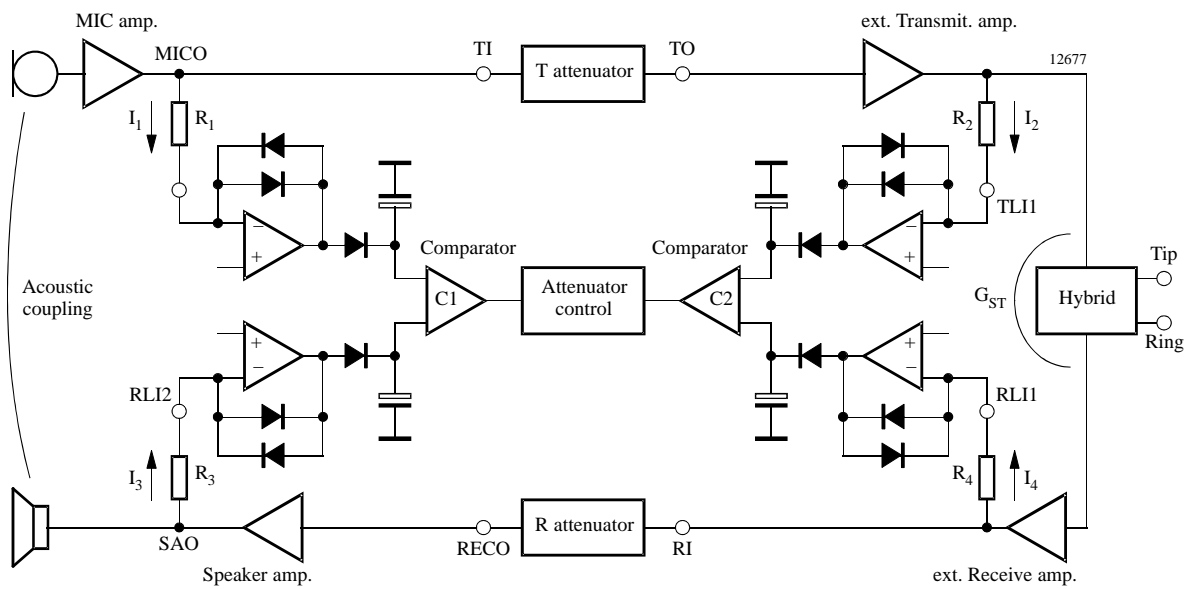

Figure 21. Basic block diagram for design purposes

**I) Loop Gain**

The total loop gain (of figure 21) must add up to a value < 0 dB to obtain a stable circuit. This can be expressed as:

$$G_{MA} + G_T + G_{EXT} + G_{ST} + G_{EXR} + G_R + G_{SA} + G_{AC} < 0 \dots\dots 1$$

Using the typical numbers mentioned above, and using the equation  $G_T + G_R = -40\text{dB}$ , the required acoustic coupling can be determined:

$$G_{AC} < -[31 + 20.1 + (-15) + 0 + (-40) + 26.8] + -22.9 \dots\dots 2$$

An acoustic loss of at least 23 dB is necessary to prevent instability and oscillations, commonly referred to as “singing”. However, the following equations show that greater values of acoustic loss are necessary to obtain proper level detection and switching.

**II) Switching Thresholds**

To switch comparator C1, the currents  $I_1$  and  $I_3$  have to be determined. When a receive signal  $V_L$  is applied to Tip/Ring, a current  $I_3$  flows through  $R_3$  into RLI2 (see figure 21) according to the following equation:

$$I_3 = \frac{V_L}{R_3} \times \left[ G_{EXR} \times G_R \times \frac{G_{SA}}{2} \right] \dots\dots 3$$

where the terms in the brackets are in V/V gain terms. The speaker amplifier gain is divided by two since  $G_{SA}$  is the differential gain of the amplifier, and  $V_3$  is obtained from one side of that output. The current  $I_1$ , coming from the microphone circuit, is defined by:

$$I_1 = \frac{V_M \times G_{MA}}{R_1} \dots\dots 4$$

where  $V_M$  is the microphone voltage. Since the switching threshold occurs when  $I_1 = I_3$ , combining the above two equations yields:

$$V_M = V_L \times \frac{R_1}{R_3} \times \frac{[G_{EXR} \times G_R \times G_{SA}]}{G_{MA} \times 2} \dots\dots 5$$

This is the general equation defining the microphone voltage necessary to switch comparator C1 when a receive signal  $V_L$  is present. The highest  $V_M$  occurs when the receive attenuator is at maximum gain (+ 6.0 dB). Using the typical values of equation 5 results in:

$$V_M = 0.52 V_L \dots\dots 6$$

To switch comparator C2, the currents  $I_2$  and  $I_4$  need to be determined. When sound is applied to the microphone, a voltage  $V_M$  is created by the microphone, resulting in a current  $I_2$  into TLI1:

$$I_2 = \frac{V_M}{R_2} \times \left[ G_{MA} \times G_T \times \frac{G_{EXT}}{2} \right] \dots\dots 7$$

Since  $G_{EXT}$  is the differential gain of the external transmit amplifiers, it is divided by two to obtain the voltage  $V_2$  applied to  $R_2$ . Comparator C2 switches when  $I_4 = I_2$ .  $I_4$  is defined by:

$$I_4 = \frac{V_L}{R_4} [G_{EXR}] \dots\dots 8$$

Setting  $I_4 = I_2$ , and combining the above equations results in:

$$V_L = V_M \times \frac{R_4}{R_2} \times \frac{[G_{MA} \times G_T \times G_{EXT}]}{G_{EXR} \times 2} \dots\dots 9$$

This equation defines the line voltage at Tip/Ring necessary to switch comparator C2 in the presence of a microphone voltage. The highest  $V_L$  occurs when the circuit is in transmit mode ( $G_T = + 6.0 \text{ dB}$ ). Using the typical values for equation 9 yields:

$$V_L = 840 V_M \text{ (or } V_M = 0.0019 V_L) \dots\dots 10$$

At idle mode, where the gain of the two attenuators is -20 dB (0.1 V/V), equations 6 and 10 yield the same result:

$$V_M = 0.024 V_L \dots\dots 11$$

Equations 6, 10, and 11 define the thresholds for switching, and are represented in figure 22.

The “M” terms are the slopes of the lines (0.52, 0.024, and 0.0019) which are the coefficients of the three equations. The  $M_R$  line represents the receive to transmit threshold in that it defines the microphone signal level necessary to switch to transmit in the presence of a given receive signal level. The  $M_T$  line represents the transmit to receive threshold. The  $M_I$  line represents the idle condition, and defines the threshold level on one side (transmit or receive) necessary to overcome noise on the other.

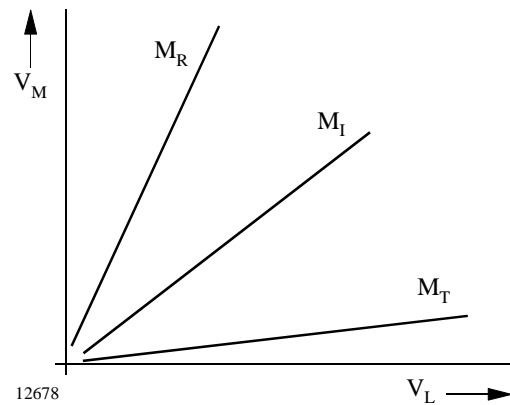

Figure 22. Switching thresholds

Some comments on the graph (figure 22):

- Acoustic coupling and side-tone coupling were not included in equations 6 and 11. Those couplings will affect the actual performance of the final speakerphone due to their interaction with speech at the microphone, and the receive signal coming in at Tip/Ring. The effects of those couplings are difficult to predict due to their associated phase shifts and frequency response. In some cases, the coupling signal will add, and other times subtract from the incoming signal. The physical design of the speakerphone enclosure, as well as the specific phone line to which it is connected, will affect the acoustic and side-tone couplings, respectively.
- The  $M_R$  line helps define the maximum acoustic coupling permissible in a system, which can be found from the following equation:

$$G_{AC(MAX)} = \frac{R_1}{2 \times R_3 \times G_{MA}} \dots \dots \dots 12$$

Equation 12 is independent of the volume control setting. Conversely, the acoustic coupling of a designed system helps determine the minimum slope of that line. Using the component values of figure 2 in equation 12 yields a  $G_{AC(MAX)}$  of -37 dB. Experience has shown, however, that an acoustic coupling loss of >40 dB is desirable.

- The  $M_T$  line helps define the maximum sidetone coupling ( $G_{ST}$ ) permissible in the system, which can be found from the following equation:

$$G_{ST} = \frac{R_1}{2 \times R_2} \dots \dots \dots 13$$

Using the component values of figure 2 in equation 13 yields a maximum side-tone of 0 dB. Experience has shown, however, that a minimum of 6.0-dB loss is preferable.

The above equations can be used to determine the resistor values for the level detector inputs. Equation 5 can be used to determine the  $R_1$ , 3 ratio and equation 9 can be used to determine the  $R_1$ - $R_2$  ratio. In figure 21,  $R_1$ - $R_4$  each represent the combined impedance of the resistor and coupling capacitor at each level detector input. The magnitude of each RC's impedance should be kept within the range of 2.0 to 15 kΩ in the voiceband (due to the typical signal levels present) to obtain the best performance from the level detectors. The specific R and C at each location will determine the frequency response of that level detector.

## Application Information

### Dial-Tone Detector

The threshold for the dial-tone detector is internally set at 15 mV (10 mV<sub>rms</sub>) below  $V_B$  (see figure 5). That

threshold can be reduced by connecting a resistor from RI to ground. The resistor value is calculated from:

$$R = 10 \text{ k} \left[ \frac{V_B}{\Delta V} - 1 \right]$$

where  $V_B$  is the voltage at Pin 12, and  $\Delta V$  the amount of threshold reduction. By connecting a resistor from  $V_S$  to RI, the threshold can be increased. The resistor value is calculated from:

$$R = 10 \text{ k} \left[ \frac{V_S - V_B}{\Delta V} - 1 \right]$$

where  $\Delta V$  is the amount of the threshold increase.

### Background-Noise Monitors

For testing or circuit analysis purposes, the transmit or receive attenuators can be set to the "on" position by disabling the background noise monitors, and applying a signal so as activate the level detectors. Grounding the CPR pin will disable the receive background-noise monitor, thereby indicating the "presence of speech" to the attenuator control block. Grounding CPT does the same for the transmit part.

Additionally, the receive background-noise monitor is automatically disabled by the dial-tone detector whenever the receive signal exceeds the detector's threshold.

### Transmit/Receive Detection Priority

Although the U4084B was designed to have an idle mode such that the attenuators are halfway between their full-on and full-off positions, the idle mode can be biased towards the transmit or the receive side. By doing so, gaining control of the circuit from idle will be easier for that side towards which it is biased since that path will have less attenuation at idle.

By connecting a resistor from  $C_T$  (Pin 11) to ground, the circuit will be biased towards the transmit side. The resistor value is calculated from:

$$R = R_T \left[ \frac{V_B}{\Delta V} - 1 \right]$$

where:

$R_T = 120 \text{ k}\Omega$  (typ.) connected between Pin 11 and 12.  $\Delta V = V_B - V_{11}$  (see figure 8).

By connecting a resistor from  $C_T$  (Pin 11) to  $V_S$ , the circuit will be biased towards the receive side. The resistor value is calculated from:

$$R = R_T \left[ \frac{V_S - V_B}{\Delta V} - 1 \right]$$

The switching time will be somewhat affected in each case due to the different voltage excursions required to get to transmit and receive from idle. For practical considerations, the  $\Delta V$  shift should not exceed 100 mV.

## Applications

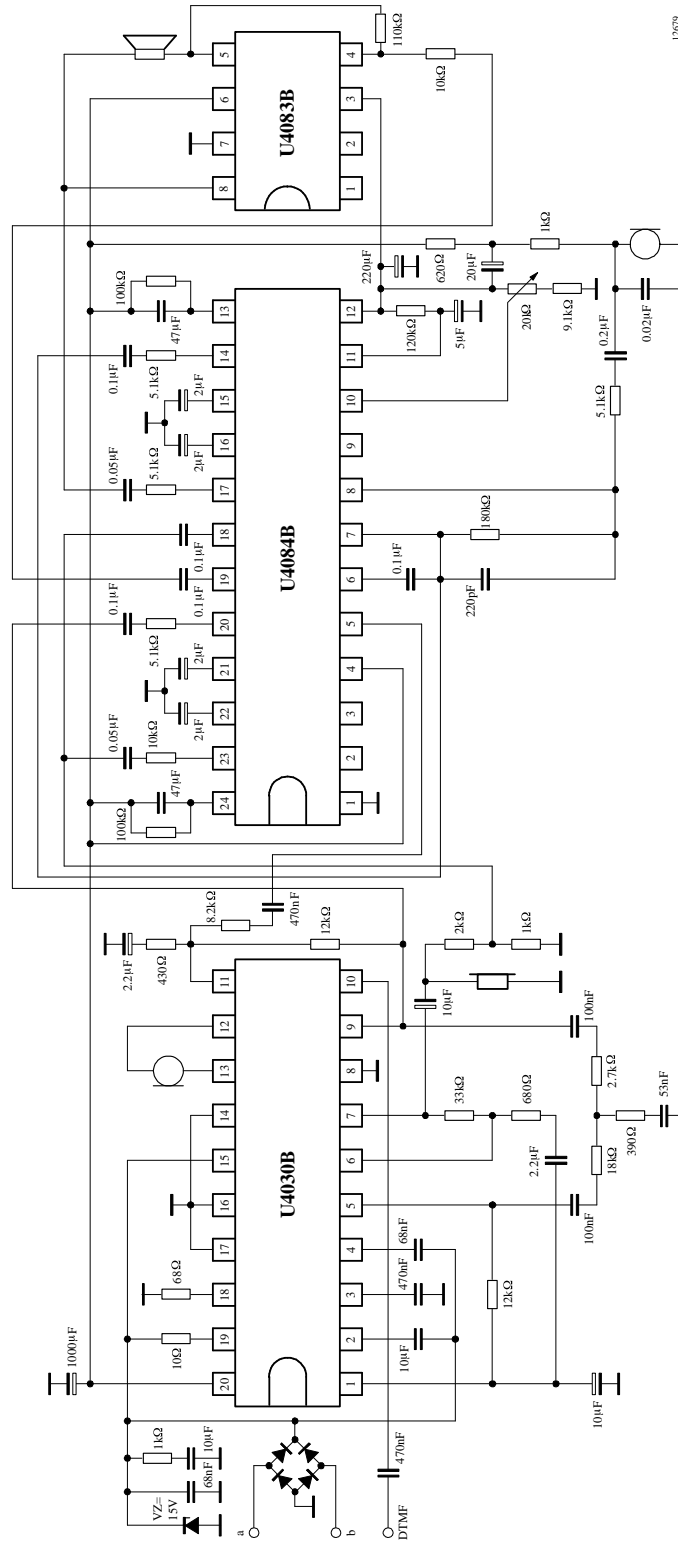

12679

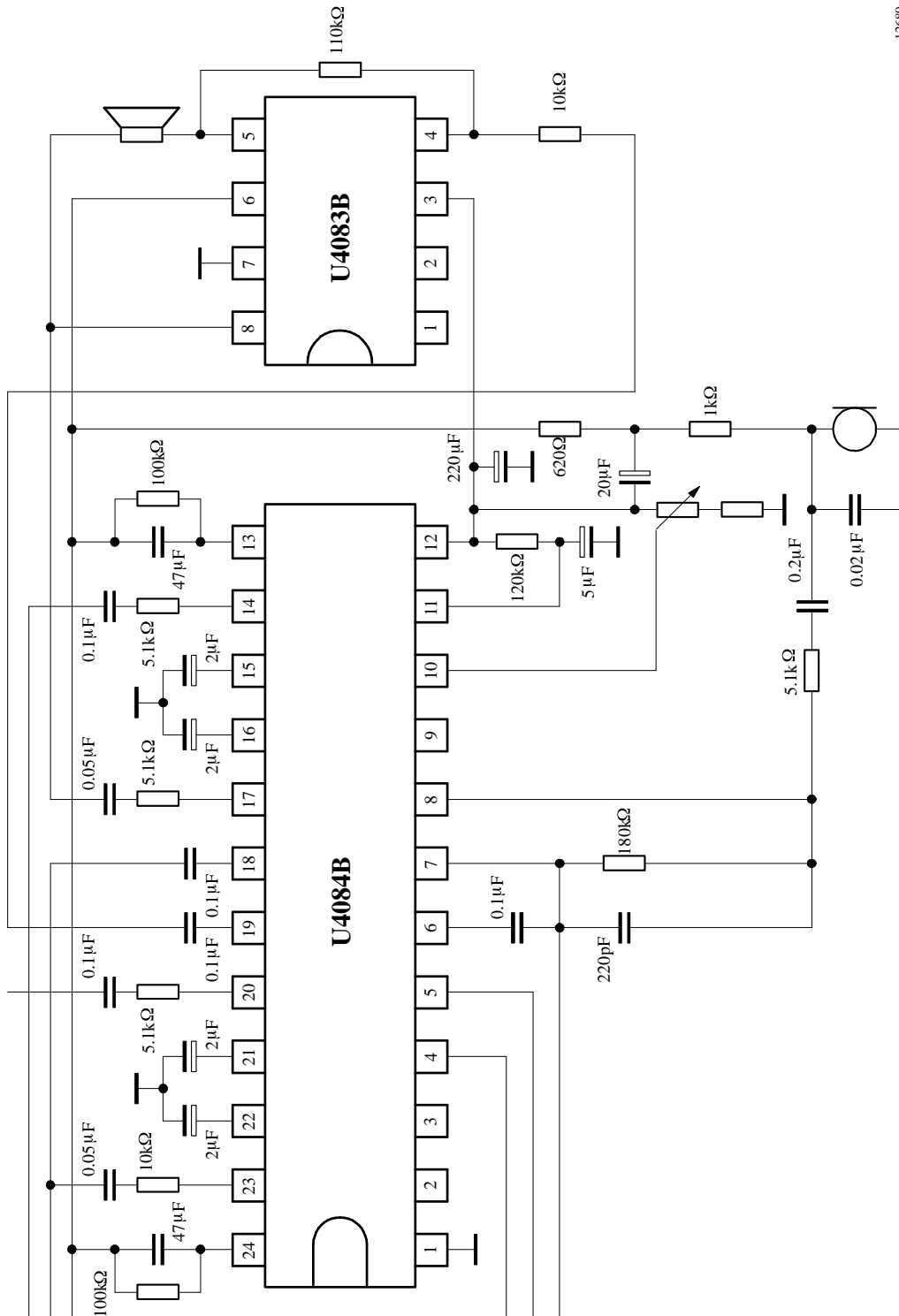

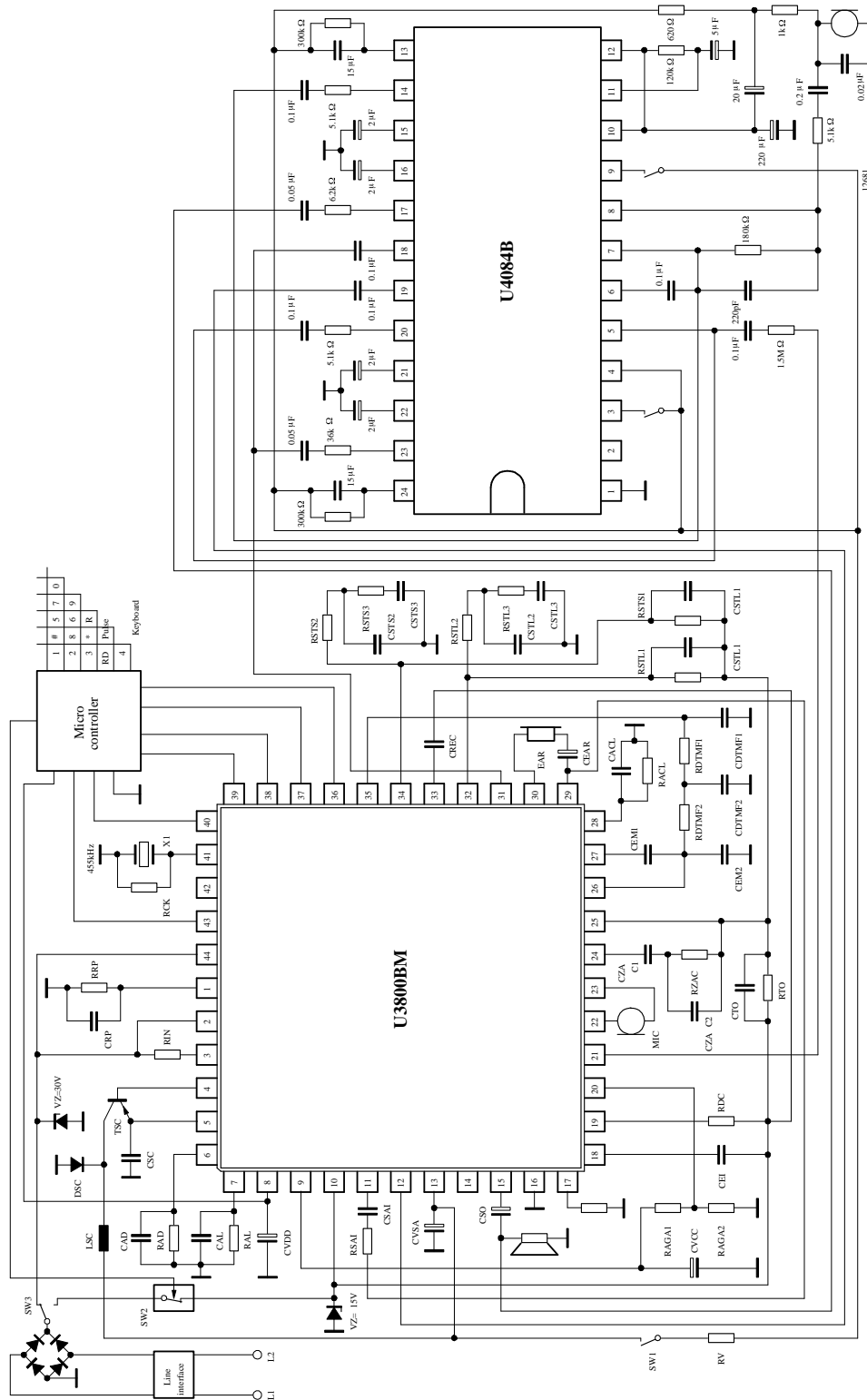

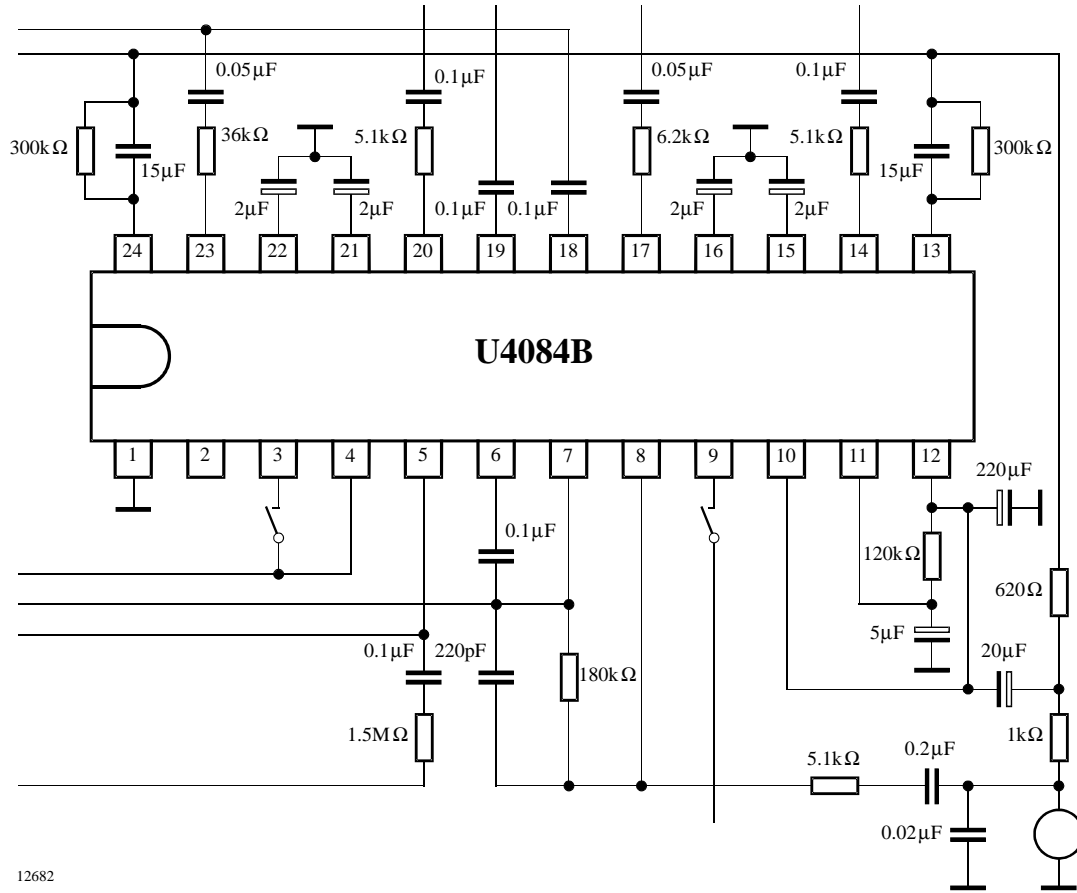

12682



## Package Information

Package DIP24 (CEI)

Dimensions in mm

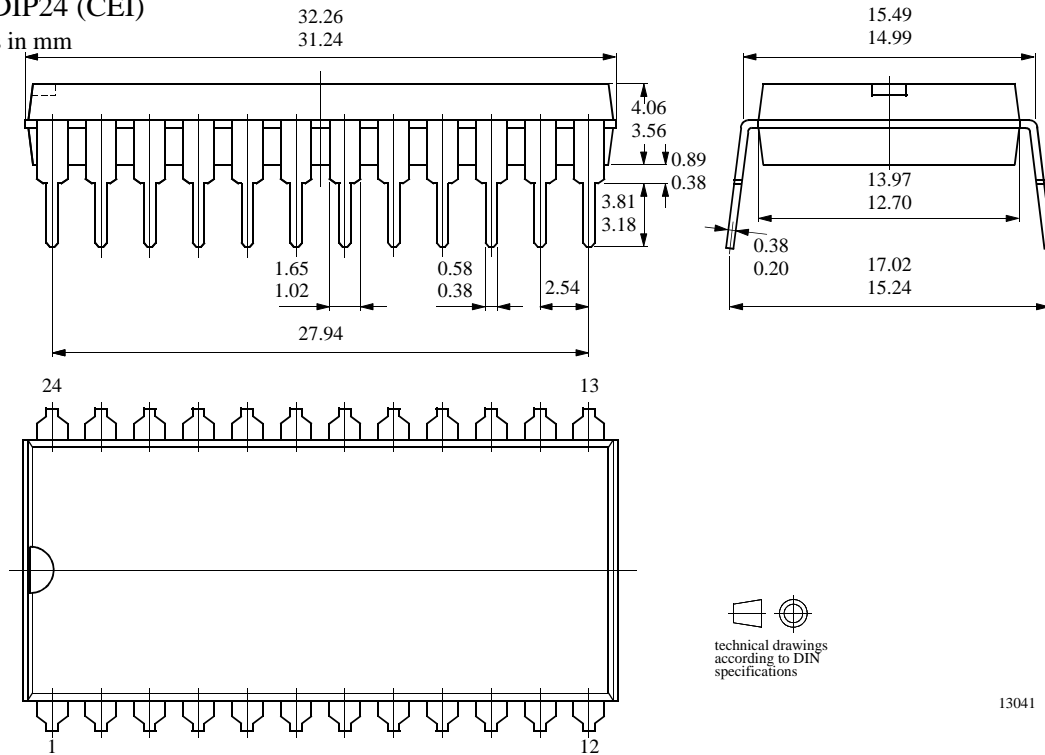

Package SO24

Dimensions in mm

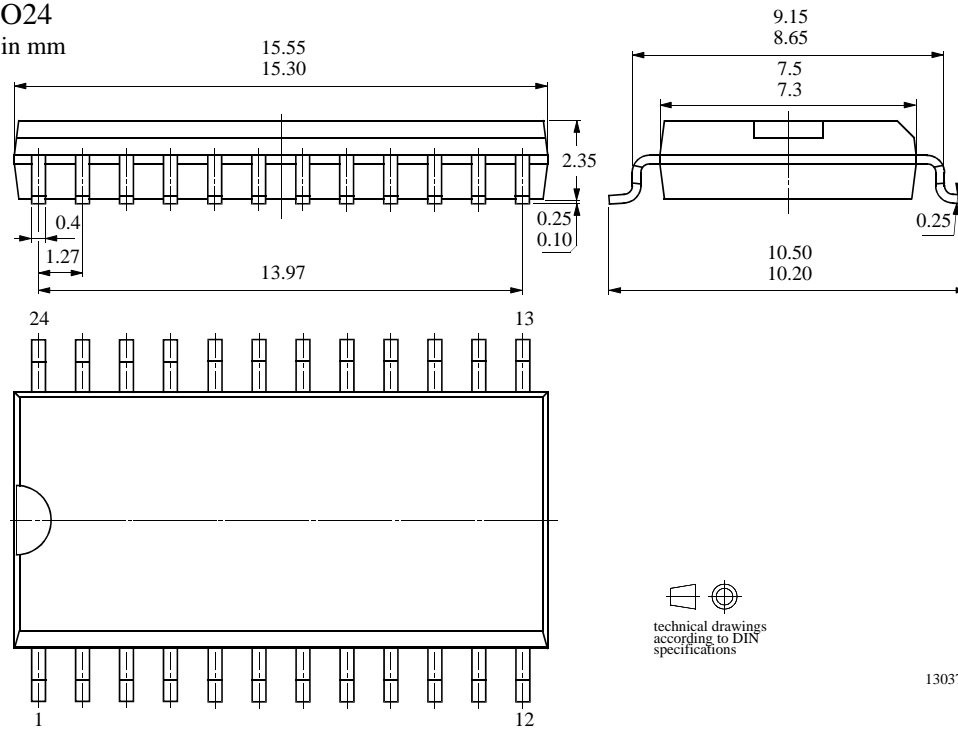

## Ozone Depleting Substances Policy Statement

It is the policy of **TEMIC TELEFUNKEN microelectronic GmbH** to

1. Meet all present and future national and international statutory requirements.
2. Regularly and continuously improve the performance of our products, processes, distribution and operating systems with respect to their impact on the health and safety of our employees and the public, as well as their impact on the environment.

It is particular concern to control or eliminate releases of those substances into the atmosphere which are known as ozone depleting substances (ODSs).

The Montreal Protocol (1987) and its London Amendments (1990) intend to severely restrict the use of ODSs and forbid their use within the next ten years. Various national and international initiatives are pressing for an earlier ban on these substances.

**TEMIC TELEFUNKEN microelectronic GmbH** semiconductor division has been able to use its policy of continuous improvements to eliminate the use of ODSs listed in the following documents.

1. Annex A, B and list of transitional substances of the Montreal Protocol and the London Amendments respectively
2. Class I and II ozone depleting substances in the Clean Air Act Amendments of 1990 by the Environmental Protection Agency (EPA) in the USA
3. Council Decision 88/540/EEC and 91/690/EEC Annex A, B and C (transitional substances) respectively.

**TEMIC** can certify that our semiconductors are not manufactured with ozone depleting substances and do not contain such substances.

**We reserve the right to make changes to improve technical design and may do so without further notice.**

Parameters can vary in different applications. All operating parameters must be validated for each customer application by the customer. Should the buyer use TEMIC products for any unintended or unauthorized application, the buyer shall indemnify TEMIC against all claims, costs, damages, and expenses, arising out of, directly or indirectly, any claim of personal damage, injury or death associated with such unintended or unauthorized use.

TEMIC TELEFUNKEN microelectronic GmbH, P.O.B. 3535, D-74025 Heilbronn, Germany  
Telephone: 49 (0)7131 67 2831, Fax number: 49 (0)7131 67 2423