

ICs for Communications

ISDN DC Converter Circuit
IDCC

PEB 2023 Version 1.1
PEF 2023 Version 1.1

Data Sheet 08.97

PEB 2023	
PEF 2023	
Revision History:	Original Version: Data Sheet 08.97
Previous Releases:	Data Sheet 02.97
Page	Subjects (changes since last revision)
all Pages	Additional to the normal temperature range devices PEB 2023 also the extended temperature range devices PEF 2023 are specified in this Data Sheet.
21	The ambient temperature under bias is separately defined for PEB 2023 and PEF 2023.
22	The maximum limit values for line regulation $V_{REF\ Line}$ and load regulation $V_{REF\ Load}$ are reduced. The typical values are adapted.
22	The maximum limit value for voltage stability of f_{OSC} is reduced. The typical value is adapted.
22	The test condition ambient temperature range T_A is extended for temperature stability of V_{REF} and f_{OSC} .
23	The sense voltage V_{Sense} of the current limit comparator is separately defined for PEB 2023 and PEF 2023.

Edition 08.97

This edition was realized using the software system FrameMaker®.

**Published by Siemens AG,
HL TS,
Balanstraße 73,
81541 München**

© Siemens AG 08.1997.

All Rights Reserved.

Attention please!

As far as patents or other rights of third parties are concerned, liability is only assumed for components, not for applications, processes and circuits implemented within components or assemblies.

The information describes the type of component and shall not be considered as assured characteristics.

Terms of delivery and rights to change design reserved.

For questions on technology, delivery and prices please contact the Semiconductor Group Offices in Germany or the Siemens Companies and Representatives worldwide (see address list).

Due to technical requirements components may contain dangerous substances. For information on the types in question please contact your nearest Siemens Office, Semiconductor Group.

Siemens AG is an approved CECC manufacturer.

Packing

Please use the recycling operators known to you. We can also help you – get in touch with your nearest sales office. By agreement we will take packing material back, if it is sorted. You must bear the costs of transport.

For packing material that is returned to us unsorted or which we are not obliged to accept, we shall have to invoice you for any costs incurred.

Components used in life-support devices or systems must be expressly authorized for such purpose!

Critical components¹ of the Semiconductor Group of Siemens AG, may only be used in life-support devices or systems² with the express written approval of the Semiconductor Group of Siemens AG.

- 1 A critical component is a component used in a life-support device or system whose failure can reasonably be expected to cause the failure of that life-support device or system, or to affect its safety or effectiveness of that device or system.
- 2 Life support devices or systems are intended (a) to be implanted in the human body, or (b) to support and/or maintain and sustain human life. If they fail, it is reasonable to assume that the health of the user may be endangered.

Table of Contents	Page
1 Overview	4
1.1 Features	5
1.2 Pin Configuration	6
1.3 Pin Definitions and Functions	7
1.4 Functional Block Diagram	8
1.5 System Integration	9
1.6 Surge Protection	14
1.7 Fast Input Undervoltage Detection	15
2 Functional Description	16
3 Electrical Characteristics	20
3.1 Absolute Maximum Ratings	20
3.2 Operating Range	21
3.3 Static Thermal Resistance	21
3.4 DC Characteristics	22
4 Package Outlines	25

1 Overview

The PEB/F 2023 is a pulse width modulator circuit designed for fixed-frequency switching regulators with very low power consumption.

In telephone and ISDN-systems a high conversion yield is crucial to maintain functionality in all supply conditions via S- or U-interfaces. The PEB/F 2023 design and technology realizes high conversion efficiency and low power dissipation. The PEB/F 2023 is fully compatible with the ITU-power recommendations of the S-interface. For these reasons the PEB/F 2023 is especially suited for telephone and ISDN-environments.

Coupled with a few external components it can provide a stable 5V DC-supply for subscriber terminals (TE's) or network terminators (NT's). It can additionally be programmed for higher output voltages, e.g. to supply the S-lines.

It should be recognized that the PEB/F 2023 can also be used in numerous DC/DC-conversion systems other than ISDN-power supplies. For example, in a special supply voltage range the PEB/F 2023 can be supplied from a 12V battery.

For detailed technical information about "**Processing Guidelines**" and "**Quality Assurance**" for ICs, see our "**Product Overview**".

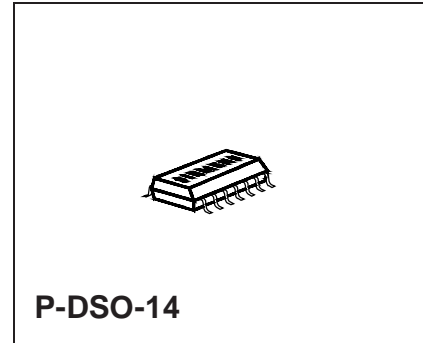

1.1 Features

- Switched Mode DC/DC Converter
- ITU ISDN Compatible
- Low Power Dissipation
- Supply Voltage Range 0: 8V to 16V
- Supply Voltage Range 1: 12V to 80V
- Supply Voltage Range 2: 22V to 90V
(pin striping selects between range 1 and range 2)
- Supply Voltage Range 3, with shifting by an external zener diode: $U_{ZD}+8V$ to $U_{ZD}+90V$
(minimum zener voltage $U_{ZD} = 14V$)
- Programmable Overcurrent Protection
- Soft Start
- Power Housekeeping Input
- Input Undervoltage Detection
- High Input Impedance ($<10\mu A$) During Undervoltage Condition
- Oscillator Synchronization Input/Output
- High Voltage Smart Power Technology 75V
- P-DSO-14/1 Package

Type	Ordering Code	Package
PEB 2023	Q67100-H6830	P-DSO-14
PEF 2023	Q67220-H1059	P-DSO-14

1.2 Pin Configuration

(top view)

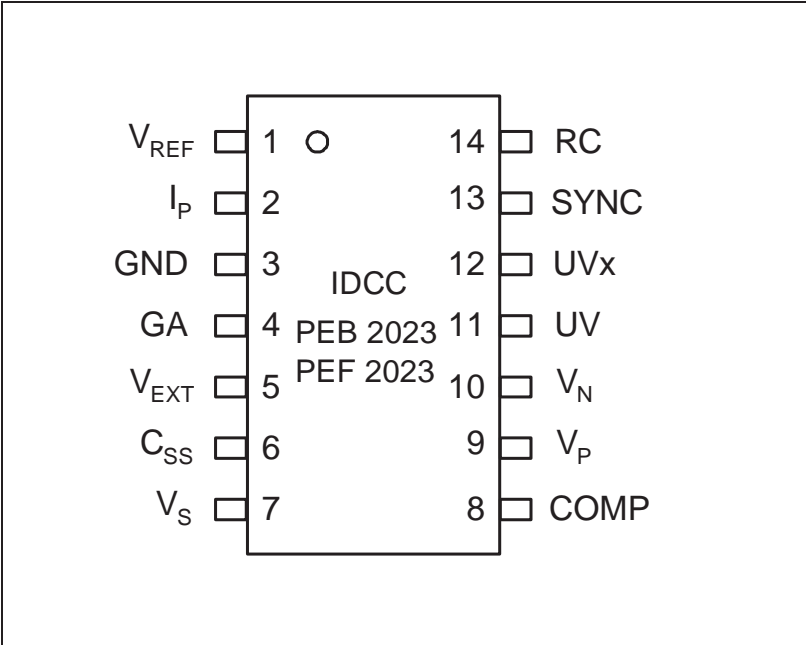

1.3 Pin Definitions and Functions

Pin No.	Symbol	Input (I) Output (O)	Function
1	V_{REF}	O	Output of the 4V reference voltage.
2	I_P	I	When the voltage difference between I_P and GND exceeds 100mV, the digital current limiting becomes active and turns off the external FET for the rest of this oscillator period.
3	GND	I	All analog and digital signals are referred to this pin.
4	GA	O	Output of the FET-driver.
5	V_{EXT}	I/O	Output of the internal supply. Via V_{EXT} the internal low-voltage-circuits can be supplied from an external DC-supply in order to reduce chip power dissipation. In supply voltage range 0 the positive supply voltage must be connected via a resistor to this pin.
6	C_{SS}	I	The capacitor at this pin determines the soft-start characteristic.
7	V_S	I	V_S is the positive input voltage for supply voltage range 1, 2 and 3. Must be connected to GND via a resistor when using supply voltage range 0.
8	COMP	O	Error amplifier output and Pulse Width Modulator (PWM) input for loop stabilization network.
9	V_P	I	Non-inverting input of the error amplifier.
10	V_N	I	Inverting input of the error amplifier.
11	UV	I	Input undervoltage lockout. The input undervoltage lockout level depends on the used supply voltage range. Must be connected to pin V_S when using supply voltage range 0.
12	UVx	I	If this pin is connected to UV, then supply range 1 is selected. If this pin is not connected (floating), then supply range 2 or supply range 3 can be used. Must be connected to pin V_{EXT} when using supply voltage range 0.
13	SYNC	I/O	Input for synchronization of the oscillator to an external frequency, or output to synchronize multiple devices.
14	RC	I	The external timing components of the ramp generator are attached to this pin.

1.4 Functional Block Diagram

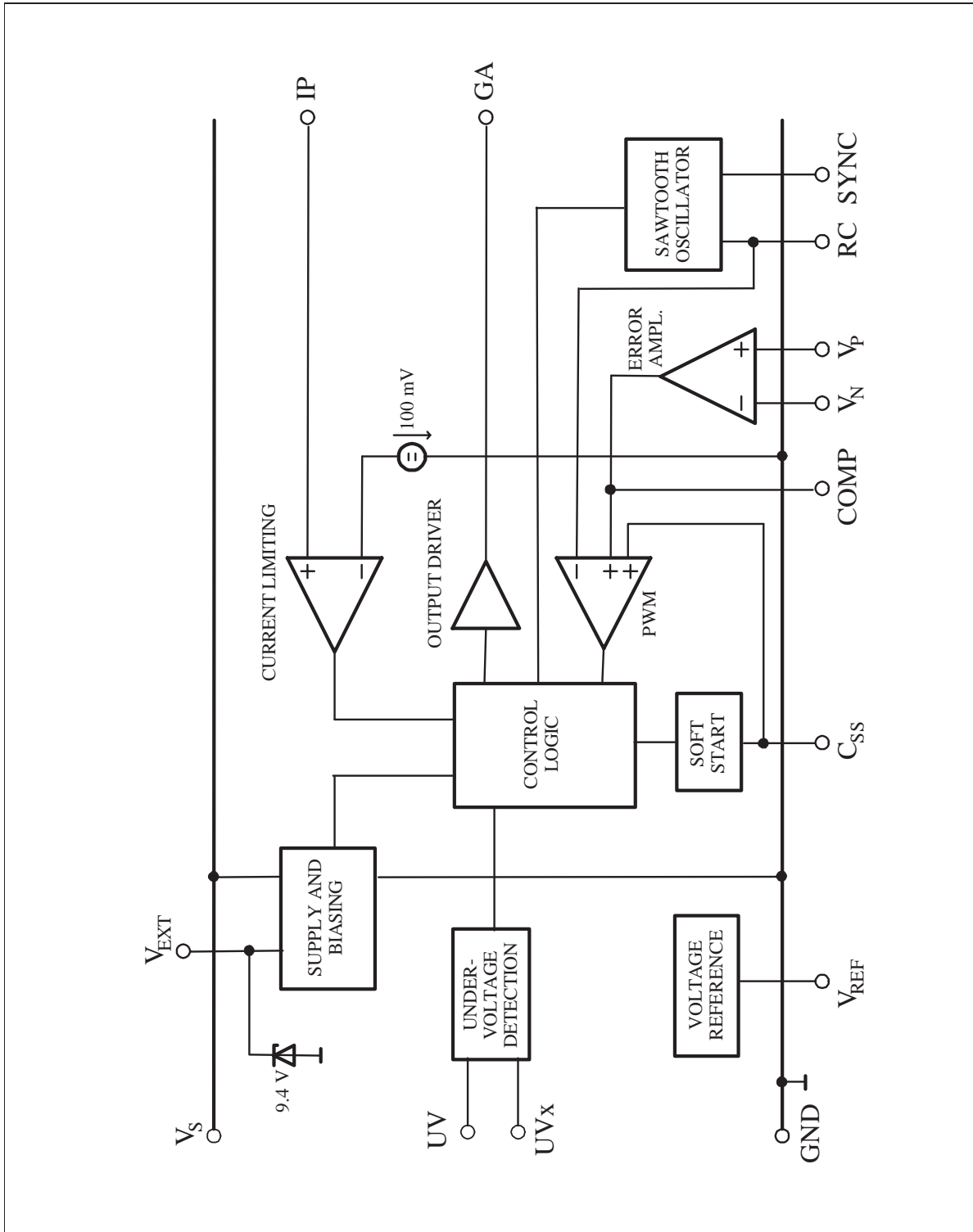

Figure 1
Block Diagram

1.5 System Integration

Figure 2 and 3 showing examples out of the wide application field of the PEB/F 2023. In network termination applications, the PEB/F 2023 supplies the internal IC's directly from the U-interface. If the local main supply of the NT is out of order, then the PEB/F 2023 will also supply the S-interface (restricted power mode).

In the subscriber terminal the PEB/F 2023 is used for feeding the internal circuits.

The PEB/F 2023 accommodates both galvanically isolated and non-isolated configurations. Considering the diversity of DC/DC-converter applications, this part of the specification only shows how to use the special ISDN-features of the PEB/F 2023.

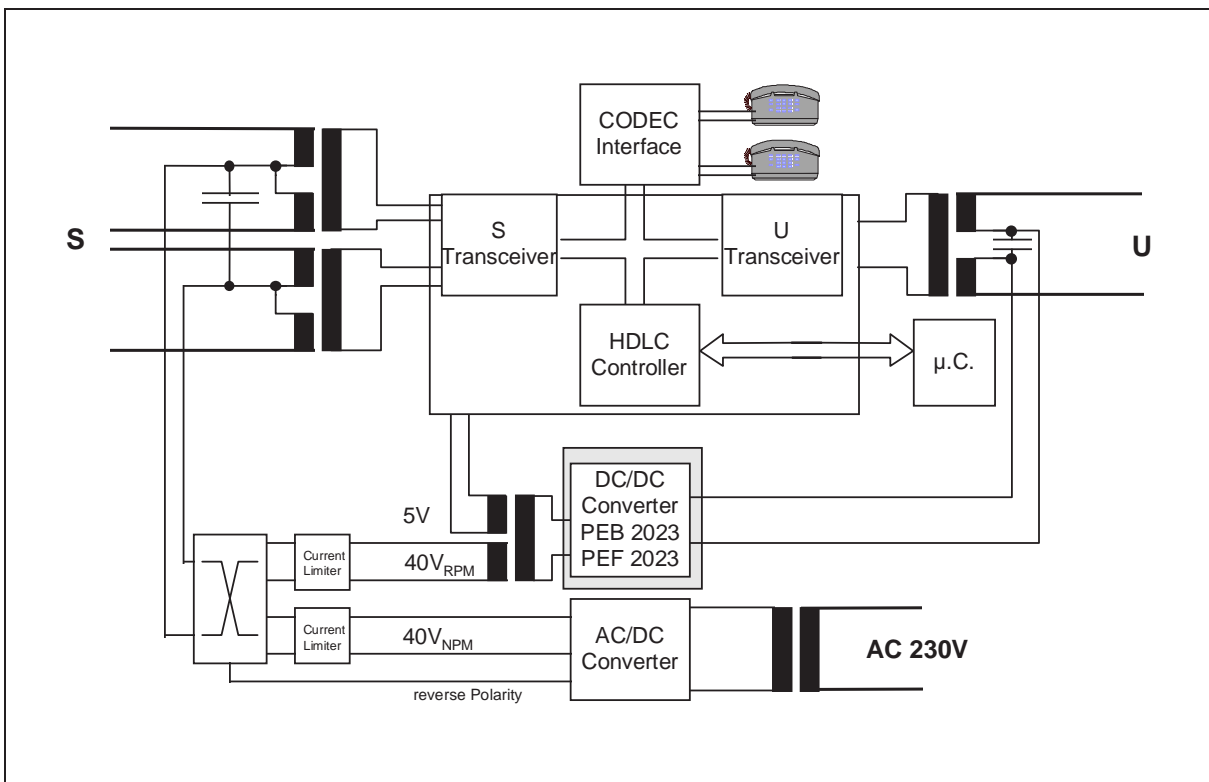

Figure 2
PEB/F 2023 in ISDN-Concept

In **figure 3** the S-transformers are replaced by the PEB/F 3023 which is called S-Feeder. When using the S-Feeder a capacitive coupling between S-receive-path and the S-Transceiver is necessary. For the S-transmit-path the S-Feeder need an extra 2.4V transmitter supply voltage. Because of the DC-voltage-drop on the S-Feeder (about 2V and 4V) the input voltages V_{RPM} and V_{NPM} must be increased (to about 42V and 44V).

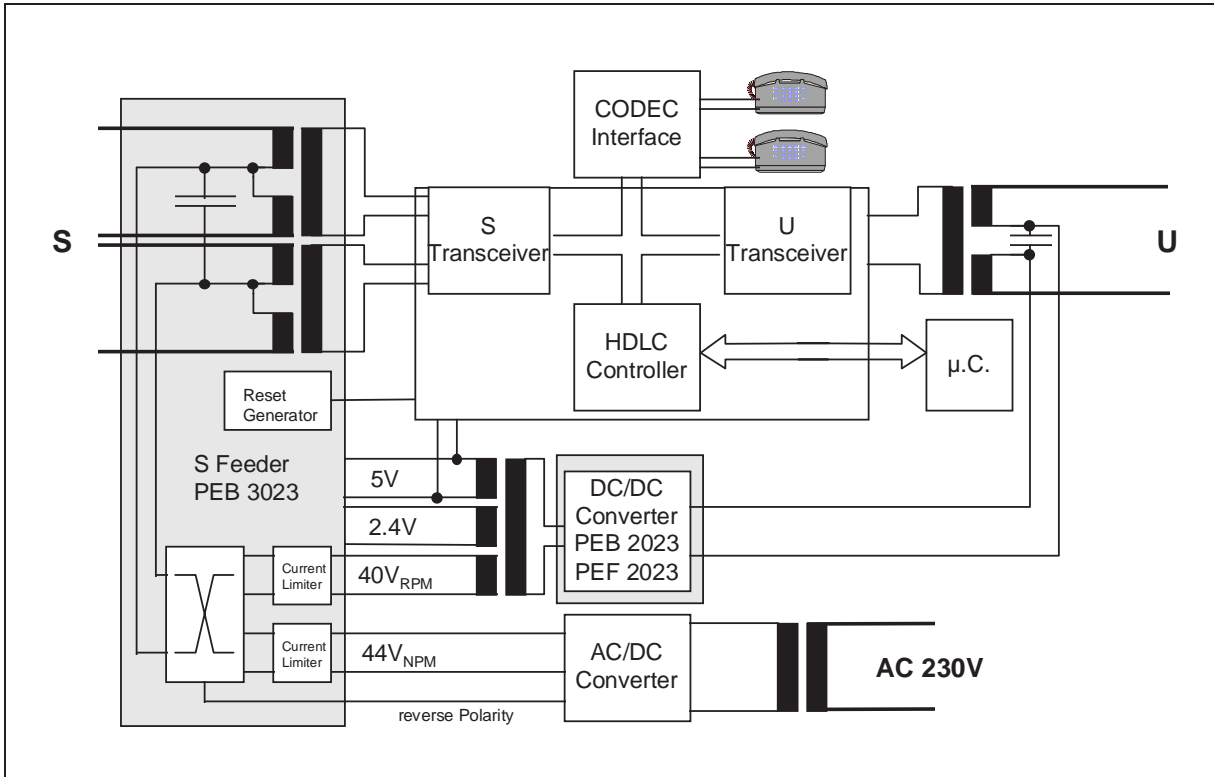

Figure 3
PEB/F 2023 in ISDN-Concept

Figure 4 shows the PEB/F 2023 in flyback configuration with transformer isolation using supply voltage range 3. This application circuit is used to supply the internal IC's of the NT from the U-interface and also to supply the S-interface in case of restricted power mode. The DC/DC-converter begins operating when the input voltage exceeds 38V ($U_{ZD}+8V$, see supply voltage range 3). In the start-up phase the PEB/F 2023 is supplied through V_S . After this start-up phase, the PEB/F 2023 is supplied via V_{EXT} (power housekeeping input) and the DC/DC-converter will operate until the input voltage falls below 20V (input undervoltage detection). For power saving reasons the value of resistor R_6 is as high as possible.

The maximum static V_S supply voltage in this example is 120V. How to get a higher maximum dynamic V_S supply voltage see chapter „1.6 Surge Protection“ on pages 14 and 15.

To get a very fast input undervoltage detection see chapter „1.7 Fast Input Undervoltage Detection“ on page 15.

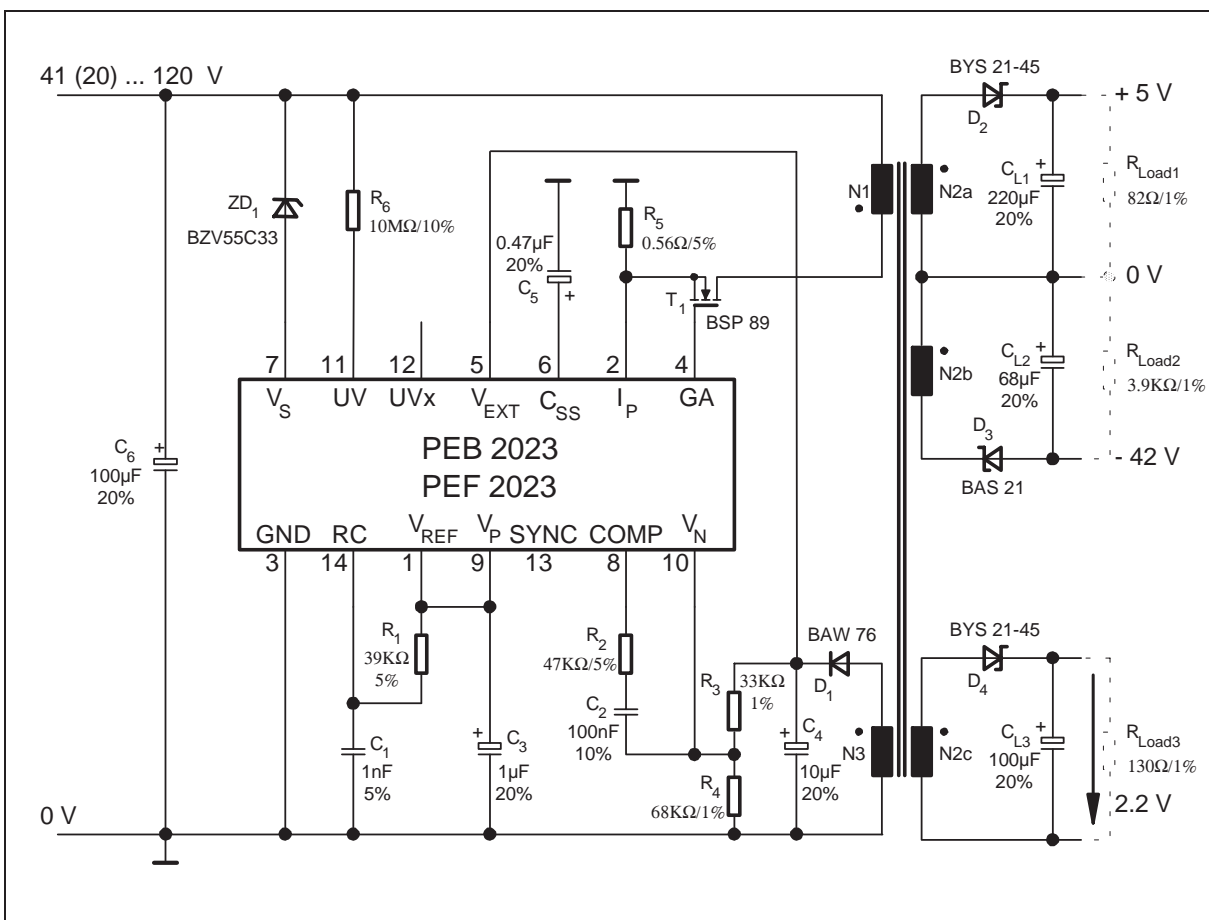

Figure 4
PEB/F 2023 in Flyback Configuration with Transformer Isolation

Figure 5 shows the PEB/F 2023 in a non-isolated minimum configuration by using supply voltage range 1 (for this input voltages also supply voltage range 2 is possible). The voltage drop over R_6 is the difference between input voltage and undervoltage detection level. To get low power dissipation the value of resistor R_6 should be as high as possible. The minimum current through R_6 is about 100nA, the maximum current is 1mA (see absolute maximum ratings).

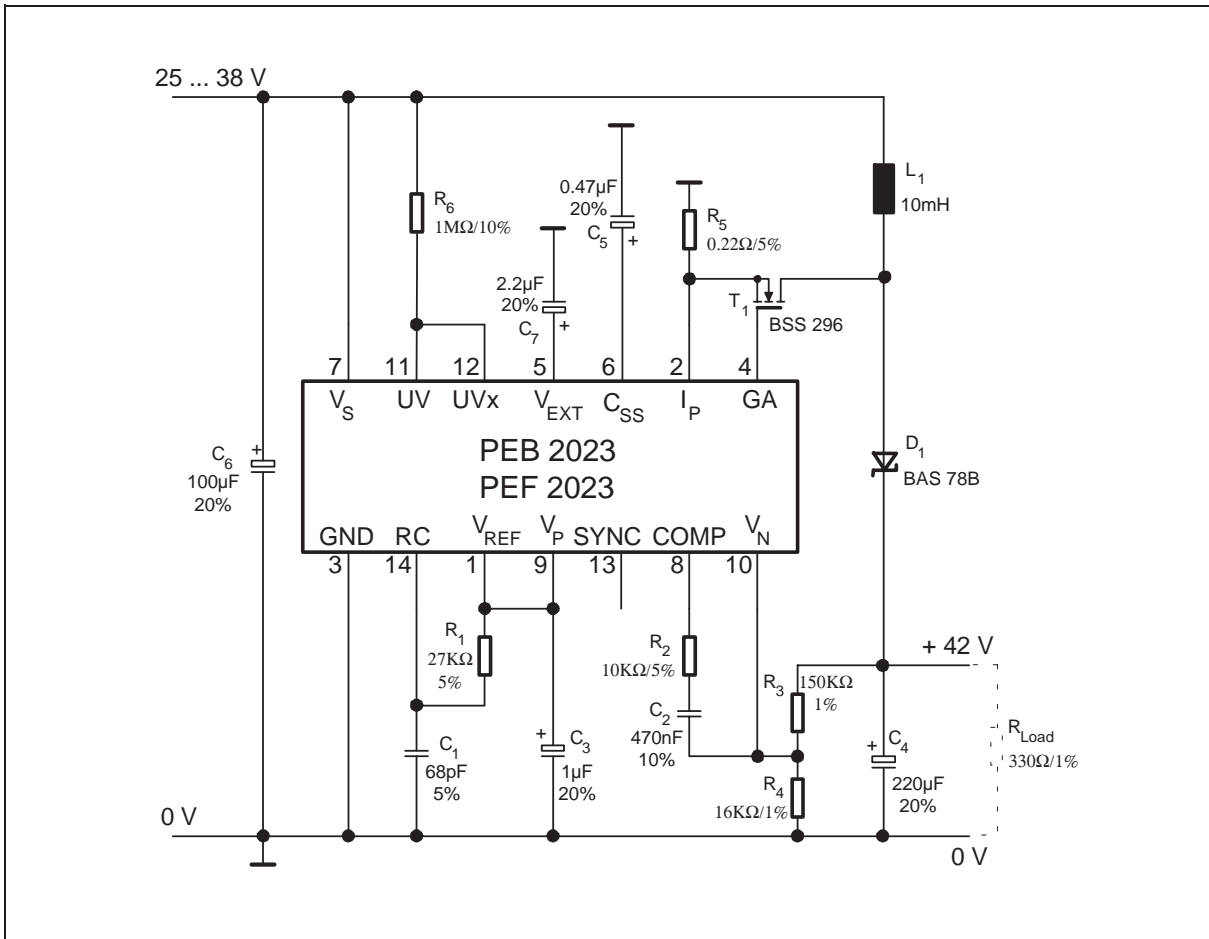

Figure 5
PEB/F 2023 in a non-isolated Minimum Configuration

Figure 6 shows the PEB/F 2023 in a non-isolated flyback configuration with transformer using supply voltage range 0. The voltage drop over R_6 is $V_{EXT}-1V$. To get low power dissipation the value of resistor R_6 , should be as high as possible. For calculating the value of resistor R_6 the minimum current through R_6 is about 100nA and the maximum current is about 100μA.

For calculation of resistor R₇:

$$\begin{aligned}
 V_{IN}, \text{ input voltage : } & V_{INmin} = 8V, & V_{INmax} &= 16V \\
 & V_{EXT} : & V_{EXTmin} &= 6V, & V_{EXTmax} &= 9V \\
 I_{R7}, \text{ input current : } & I_{R7min} = 1mA, & I_{R7max} &= 6mA
 \end{aligned}$$

$$R_{7min} = \frac{V_{INmax} - V_{EXTmax}}{I_{R7max}} = 1,667k\Omega \qquad R_{7max} = \frac{V_{INmin} - V_{EXTmin}}{I_{R7min}} = 2k\Omega$$

To get lower power dissipation the value of resistor R₇ should also be as high as possible. For this reason we use R_{7max}. If in the calculation above R_{7min} is higher than R_{7max}, then the input voltage range is not correct; V_{INmax}-V_{INmin} is too large.

Note: If V_{INmin} = 6V and V_{INmax} = 9V then the resistor R₇ is not necessary. The input voltage V_{IN} can directly be connected to V_{EXT}.

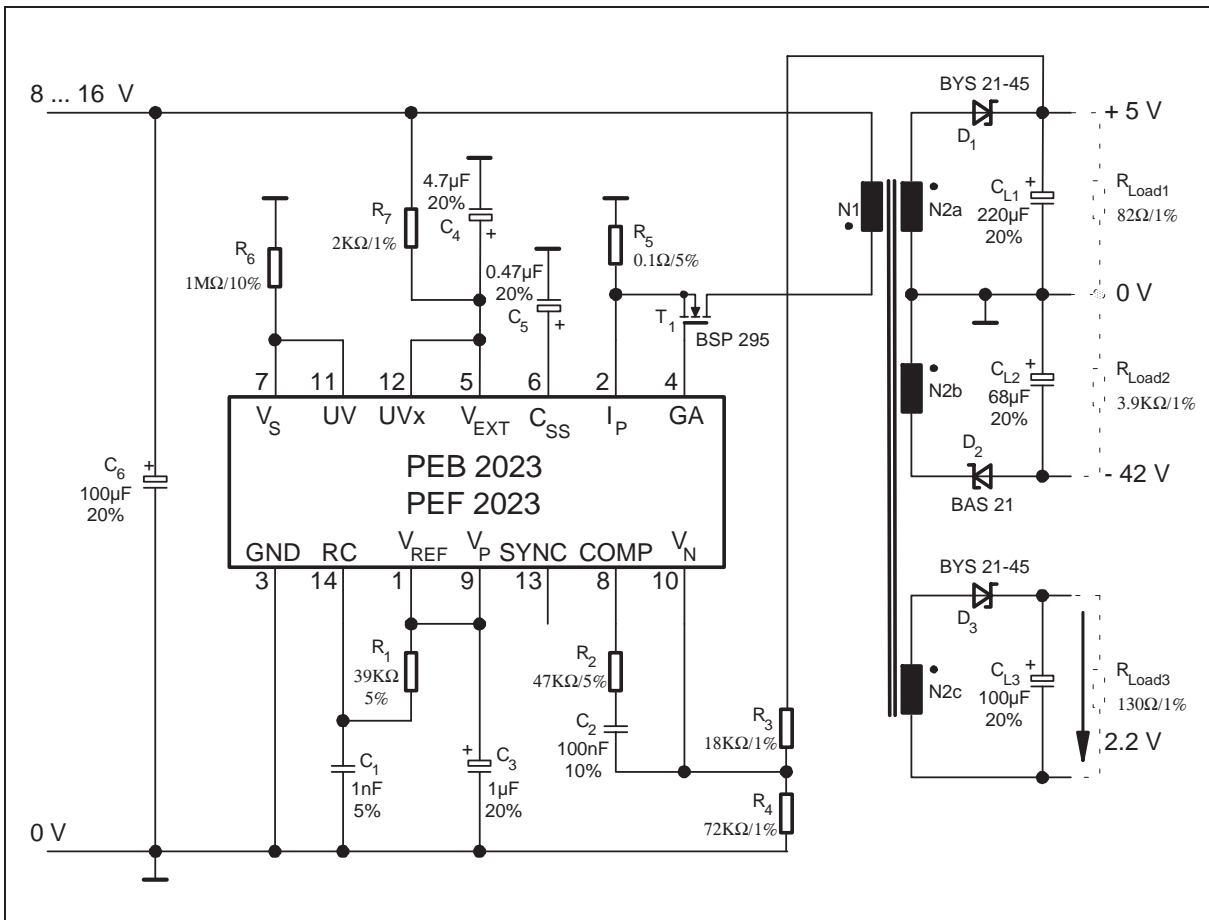

Figure 6
PEB/F 2023 in a non-isolated Flyback Configuration

1.6 Surge Protection

In telephone and ISDN-systems the topic “surge protection” or “lightning overvoltage protection” is very important. For the PEB/F 2023 overvoltage protection is necessary when the DC/DC converter input supply voltage V_{IN} is connected to the U- or S-interface-lines.

Figure 7 shows how to protect the PEB/F 2023 when using supply voltage range 3 (see also figure 4). For supply voltage ranges 1 and 2 the principle is the same.

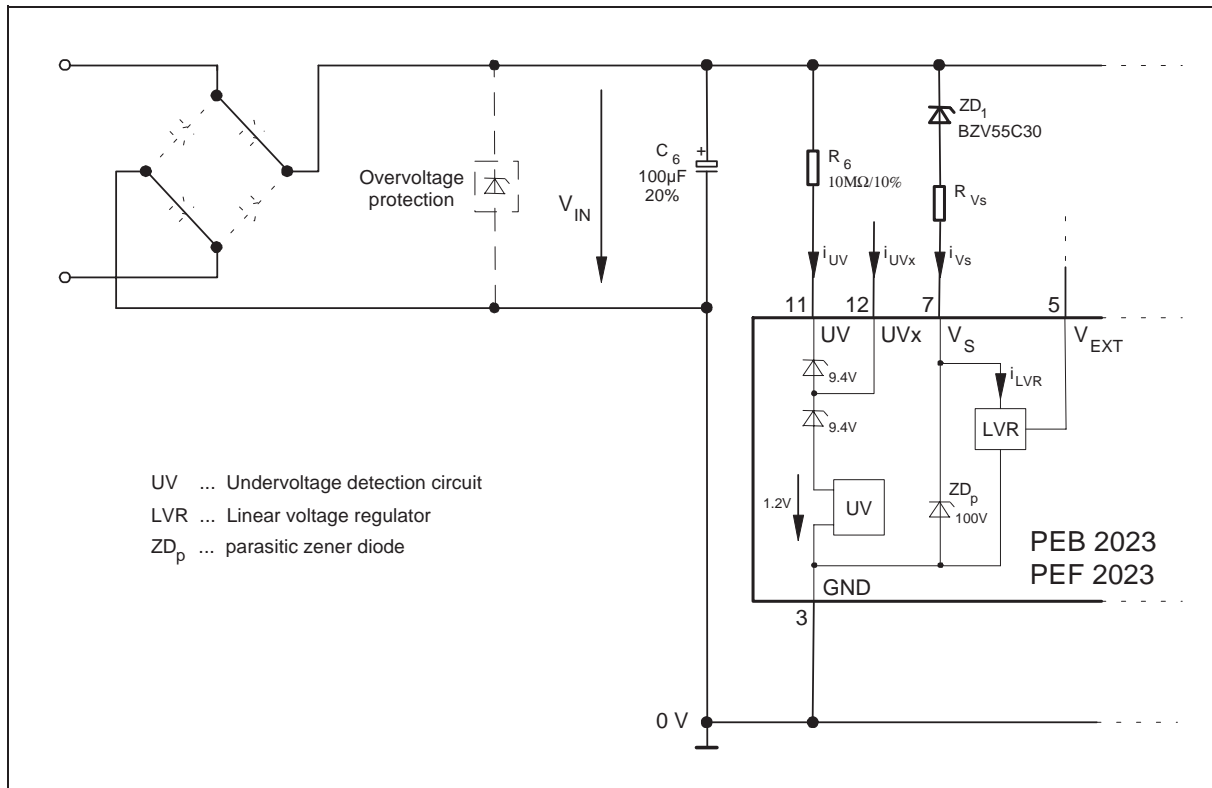

Figure 7
PEB/F 2023 Surge Protection

The DC/DC converter begins operating when the input voltage exceeds $V_{ZD1}+8V+V_{RVs}$. In the start-up phase the PEB/F 2023 is supplied through V_S . After this start-up phase, the PEB/F 2023 is supplied via V_{EXT} (power housekeeping input, see figure 4) and the DC/DC-converter will operate until the input voltage falls below 20V (input undervoltage detection).

The current i_{LVR} needed in the start-up phase is less than $500\mu A$. With this current and the value of resistor R_{Vs} the voltage V_{RVs} can be calculated.

For static and transient currents i_{UV} and i_{UVx} , respectively, absolute maximum ratings are valid. Because of the high value of R_6 (for power saving reasons), i_{UV} and i_{UVx} normally are sufficiently low.

Limits for voltage and current on pin V_S are also defined in the maximum ratings.

Calculation example: figure 7 with $R_{Vs} = 4,7k\Omega$

$$V_{INstart} = V_{ZD1} + 8 + (R_{Vs} \cdot i_{LVR}) = 30V + 8V + (4,7k\Omega \cdot 500\mu A) = 40,35V$$

for $t \leq 100msec$:

$$V_{INmax} = V_{ZD1} + 100 + (R_{Vs} \cdot i_{Vsmax}) = 30V + 100V + (4,7k\Omega \cdot 10mA) = 177V$$

for $t \leq 10msec$:

$$V_{INmax} = V_{ZD1} + 100 + (R_{Vs} \cdot i_{Vsmax}) = 30V + 100V + (4,7k\Omega \cdot 30mA) = 271V$$

In this example the DC/DC converter begins operating when the input voltage exceeds 40,35V. The maximum transient input voltage is 177V / 271V for a duration of 100msec / 10msec. The maximum static input voltage is given by $V_{ZD1} + 90V = 120V$, see absolute maximum ratings.

1.7 Fast Input Undervoltage Detection

With three extra devices (D_5 , D_6 and R_8 , see **figure 8**) an undervoltage state on the input can be detected faster than the voltage on capacitor C_6 decreases. See also chapter „undervoltage lockout“ on page 17.

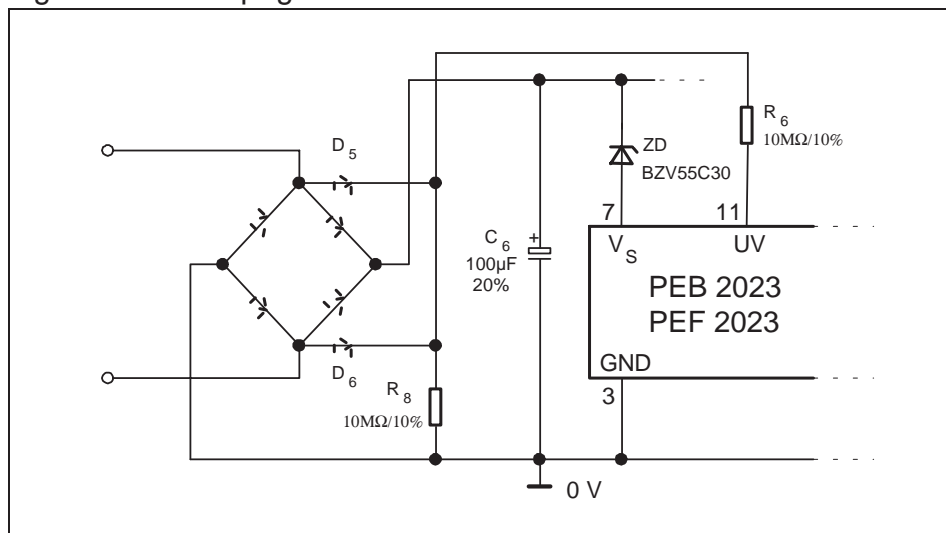

Figure 8
PEB/F 2023, Fast Input Undervoltage Detection

2 Functional Description

The PEB/F 2023 contains the following functional blocks:

- Supply and Biasing
- Undervoltage Detection
- Temperature Compensated Voltage Reference
- Sawtooth Oscillator
- Error Amplifier
- Pulse Width Modulator
- Digital Current Limiting
- Soft Start
- Control Logic (double pulse inhibit)
- Output Driver

The reference voltage provides 4V for the regulation loop. A high gain error amplifier compares the reference voltage to the output voltage. The output of the error amplifier is then compared to a periodic ramp, which is generated by the sawtooth-oscillator circuit. The comparator output is a fixed-frequency, variable pulse width logic signal, which passes through logic circuits and the output driver and out to the external high voltage power-switching-FET.

A digital current limiting device suppresses the PWM logic signal when the voltage difference between current limit sense input I_P and GND reaches 100 mV to protect the external power-switching-FET.

Non-isolated and isolated SMPS-configurations are possible. Logic and analog circuits are implemented in BICMOS in order to achieve low power dissipation.

Start-Up Procedure

Before the switched-mode DC/DC converter starts, a sequence of several conditions has to be passed in order to avoid any system malfunction.

An integrated 6V linear voltage regulator supplies the internal low-voltage BICMOS-circuits from the input voltage V_S . The generated supply voltage is connected to pin V_{EXT} and has to be buffered by an external capacitor ($C_{min} = 1\mu F$). Power dissipation of the linear voltage regulator can be reduced, if an external supply is used for that purpose by connecting it to pin V_{EXT} . If the input voltage at V_{EXT} is greater than 6.2V, the internal linear voltage regulator turns off and the internal BICMOS-circuits are then fed from the external voltage source (power housekeeping input V_{EXT}). In this case, the input current at V_{EXT} is approximately 0.6mA.

Functional Description

Note: *An internal 9.4V zener diode protects the V_{EXT} input against overvoltages. The maximum zener current is 6mA! If the external supply isn't stabilized, the input current must be limited (e.g. by a resistor, see also supply voltage range 0)!*

Supply Voltage Ranges

Supply Voltage Range 0: 8V to 16V

In this supply voltage range the PEB/F 2023 can be supplied from a 12V battery. Connect the positive supply voltage via a resistor (R_7 in figure 6) to pin V_{EXT} and pin V_S via a resistor (R_6 in figure 6) to GND. Pin UV must be connected to pin V_S . Pin UVx must be connected to pin V_{EXT} . For calculating the values of the two resistors R_6 and R_7 , see the description of figure 6.

Supply Voltage Range 1: 12V to 80V

Connect the input voltage to pin V_S and via a resistor (R_6 in figure 5) to pins UV and UVx. For calculating the value of this resistor see the description of figure 5.

Supply Voltage Range 2: 22V to 90V

Connect the input voltage to pin V_S and via a resistor to pin UV. Pin UVx is not connected (floating).

Supply Voltage Range 3: $U_{ZD}+8V$ to $U_{ZD}+90V$

Connect the input voltage via a zener diode (minimum zener voltage $U_{ZD} = 14V$) to pin V_S and via a resistor (R_6 in figure 4) to pin UV. Pin UVx is not connected (floating).

Undervoltage Lockout

At the undervoltage detection pin UV, a resistor with a value of about 100k Ω ..10M Ω is required to protect this pin against high currents (see absolute maximum ratings). The level of undervoltage detection when using supply voltage range 1 is 8V..12V, using supply voltage range 2 or 3, it is 18V..22V. To get a higher undervoltage detection level a zener diode in series with the resistor is required.

When the PEB/F 2023 detects an undervoltage condition, the gate output driver will be turned off. The DC/DC conversion is disabled and the PEB/F 2023 shows a high input impedance seen from the undervoltage detection pins (UV, UVx) and from pin V_S to GND. Also the voltage on V_{EXT} will decrease. When the undervoltage condition is removed, the DC/DC converter will be enabled once again with a soft start.

Note: *When using supply voltage range 0 the undervoltage detection circuit is not working. The resistor connected between V_S and GND bypasses this undervoltage detection circuit (R_6 in figure 6).*

Voltage Reference

The reference regulator of the PEB/F 2023 is based on a temperature compensated bandgap. This circuitry is fully active at supply voltages (pin V_{EXT}) above 6 volts and provides up to 0.5mA of load current to external circuitry at 4 volts. This reference has to be buffered by an external capacitor ($C_{min} = 1\mu F$).

Sawtooth Oscillator

The oscillator frequency is programmed by the two components R_1 and C_1 (see figure 4, 5 or 6). The oscillator timing capacitor C_1 is charged by V_{REF} through R_1 and discharged by an internal $10k\Omega$ discharge-resistor. The rise-time of the sawtooth oscillator can be programmed with R_1 and C_1 . The internal discharge-resistor and C_1 define the fall-time. At the beginning of the discharge period a positive synchronization pulse is generated at pin SYNC. Otherwise the PEB/F 2023 can be synchronized via pin SYNC to an external logic clock by programming the oscillator to free run at a frequency 10% lower than the synchronization frequency. The PEB/F 2023 is synchronized by the rising edge of the sync. signal. So multiple devices can be synchronized together by programming one master unit for the desired frequency (only one possible interfering frequency).

Note that the frequency of the output driver is half the oscillator frequency. The switching frequency as a function of R_1 and C_1 is shown in **figure 9**.

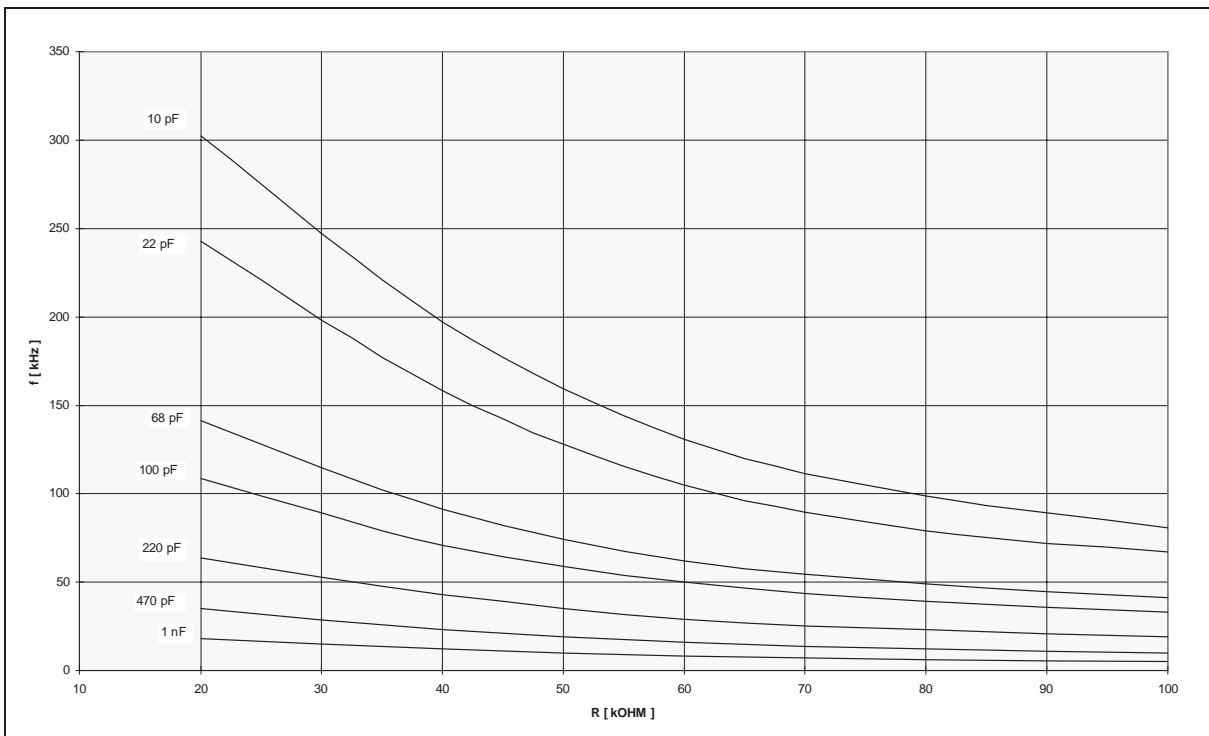

Figure 9
Switching Frequency

Functional Description**Error Amplifier**

Conventional operational amplifier for closed-loop gain and phase compensation.
Low output impedance: unity-gain stable.

Pulse Width Modulator

The pulse width modulator compares the sawtooth-voltage of the oscillator output with the output of the error amplifier and with the voltage of the external soft start capacitor at pin C_{SS} .

Current Limiting

When the sense voltage reaches a threshold voltage of 100mV a shutdown signal is sent to the control logic. Sense voltage is the voltage between pin I_p and pin GND. Because of the small value of the current-sensing-resistor (R_s in figure 4, 5 or 6) the board layout has to be done carefully.

Soft Start

The soft start circuit protects the power transistors and rectifier diodes from high current surges during power supply turn-on. When the supply voltage is connected to the PEB/F 2023 the undervoltage lockout circuit holds the soft start capacitor voltage at zero. When the supply voltage reaches the normal operating range, an internal 1.5 μ A current source will charge the external soft start capacitor. As the soft start voltage ramps up to +5 volts, the duty cycle of the PWM linearly increases to whatever value the regulation loop requires.

Control Logic

The control logic inhibits double pulses during one duty cycle and limits the maximum duty cycle to 50%.

Disable Input Realization

One way to disable the function of the PEB/F 2023 is to connect an external n-channel MOS-transistor between the pins UV(drain) and GND(source). By switching on this external transistor the PEB/F 2023 detects an 'undervoltage' and turns off. After switching off this external transistor the PEB/F 2023 turns on and starts the DC/DC conversion with a soft start.

A second possibility is to connect an external n-channel MOS-transistor between the pins C_{SS} (drain) and GND(source). By switching on this external transistor the PEB/F 2023 disables the gate output driver because of the soft start circuitry. After switching off this external transistor the PEB/F 2023 turns on and starts the DC/DC conversion with a soft start.

Electrical Characteristics

3 Electrical Characteristics

3.1 Absolute Maximum Ratings

Parameter	Symbol	Limit Values		Unit	Test Condition
		min.	max.		
Supply voltage (pin V_S) for sup. voltage range 1	V_{S1}	-0.3	80	V	Referred to GND
Supply voltage (pin V_S) for sup. voltage range 2 or 3	$V_{S2,3}$	-0.3	90	V	Referred to GND
Transient input current on pin V_S (sup. voltage range 1, 2 or 3)	i_{Vs}	-10 -30	10 30	mA mA	$t \leq 100$ msec $t \leq 10$ msec
Analog input voltage (pins I_P , COMP, V_P , V_N , SYNC, RC)	V_{IA}	-0.3	$V_{EXT} + 0.3$	V	Referred to GND
Reference output current (pin V_{REF})	$I_{O REF}$		5	mA	
SYNC-output current (pin SYNC)	$I_{O SYNC}$		5	mA	
Error amplifier output current (pin COMP)	$I_{O COMP}$		5	mA	
Z-current (pin V_{EXT})	$I_{Z EXT}$		6	mA	
Output current (pin V_{EXT})	$I_{O EXT}$		6	mA	
Driver output current (pin GA)	$I_{O DR}$		25	mA	
Undervoltage detection input currents (pins UV, UVx)	I_{UV}, I_{UVx} i_{UV}, i_{UVx}	-10	1 10	mA mA	$t \leq 10$ msec
Junction temperature	T_j	0	150	°C	
Storage temperature	T_{stg}	-40	150	°C	
ESD-voltage, all pins			1	kV	Human body model

Note: Maximum ratings are absolute ratings; exceeding only one of these values may cause irreversible damage to the integrated circuit.

Note: If not otherwise stated than this absolute maximum values are static values. For overvoltage protection (pin V_S respectively UV and UVx) see chapter 1.6 Surge Protection.

Electrical Characteristics

3.2 Operating Range

Parameter	Symbol	Limit Values		Unit	Test Condition
		min.	max.		
Ambient temperature under bias					
PEB 2023	T_A	0	70	°C	
PEF 2023	T_A	-40	85	°C	
Supply voltage (pin V_S) for sup. voltage range 1	V_{S1}	12	80	V	Referred to GND
Supply voltage (pin V_S) for sup. voltage range 2 or 3	$V_{S2,3}$	8	90	V	Referred to GND

Note: In the operating range the functions given in the circuit description are fulfilled.

3.3 Static Thermal Resistance

Parameter	Symbol	Limit Values		Unit	Test Condition
		min.	max.		
Junction to ambient	$R_{th,jA}$		112	K/W	P-DSO-14

Electrical Characteristics

3.4 DC Characteristics

Parameter	Symbol	Limit Values			Unit	Test Condition
		min.	typ.	max.		
Supply current (pin V_S to GND)	I_S		6	12	μA	$V_{EXT} = 6.2\text{V}$, $V_S = 40\text{V}$

Reference V_{REF}

Output voltage	$V_{REF O}$	3.96	4.0	4.04	V	$T_A = 25^\circ\text{C}$, $I_L = 0\text{mA}$, $V_S = 40\text{V}$
Line regulation	$V_{REF Line}$		0.1	5	mV	$T_A = 25^\circ\text{C}$, $V_S = 25$ to 65V , $I_L = 0\text{mA}$,
Load regulation	$V_{REF Load}$		2	5	mV	$T_A = 25^\circ\text{C}$, $I_L = 0.1$ to 0.3mA , $V_S = 40\text{V}$
Temperature stability	$V_{REF TS}$		10	20	mV	$T_A = -40$ to 85°C , $I_L = 0\text{mA}$, $V_S = 40\text{V}$

Oscillator SYNC, RC

$f_{OSC} = 20\text{kHz}$, $R_T = 39\text{k}\Omega \pm 1\%$, $C_T = 1\text{nF} \pm 1\%$

Initial accuracy	Δf_O		± 5	± 10	%	$T_A = 25^\circ\text{C}$, $V_S = 40\text{V}$
Voltage stability of f_{OSC}	$\Delta f_{O Line}$		± 0.1	± 1	%	$T_A = 25^\circ\text{C}$, $V_S = 25$ to 65V
Temperature stability of f_{OSC}	$\Delta f_{O TS}$			± 5	%	$T_A = -40$ to 85°C , $V_S = 40\text{V}$
Max. frequency	f_{max}	550			kHz	$R_T = 20\text{k}\Omega$, $C_T = 10\text{pF}$
H-sawtooth voltage	V_H	3.0	3.2	3.4	V	
L-sawtooth voltage	V_L	1.6	1.8	2.0	V	
H-sync output level	V_{SYNCH}	2.4	3.5	5.25	V	$I_L = 0.5\text{mA}$, $V_{EXT} = 6.2\text{V}$
L-sync output level	V_{SYNCL}		0.2	0.8	V	$I_L = 20\mu\text{A}$

Pulse Width Modulator

Duty cycle	t_d	0		50	%	
------------	-------	---	--	----	---	--

Soft Start C_{SS}

Charging current	I_C	1	1.5	2	μA	$V_{CSS} = 0\text{V}$
------------------	-------	---	-----	---	---------------	-----------------------

Electrical Characteristics

DC Characteristics (cont'd)

Parameter	Symbol	Limit Values			Unit	Test Condition
		min.	typ.	max.		

Error Amplifier
COMP, V_P , V_N

Input offset voltage	V_{IO}	-10		10	mV	$V_{CM} = 3.0V$
Input current	I_I		25	50	nA	
Common mode range	V_{CMR}	1.8		4.5	V	
DC open loop gain	G_{VO}	60	70		dB	
Common mode rejection	k_{CMR}	60	70		dB	$f \leq 10kHz$
Unity gain bandwidth	f	0.5	1		MHz	$C_L (pin) = 10pF$
Supply voltage rejection V_{EXT} / V_{COMP}	k_{SVR}	60	70		dB	$f \leq 10kHz$
H-output voltage	V_{OH}	4.5			V	$I_L = 100\mu A$
L-output voltage	V_{OL}		0.02	0.1	V	$I_L = 10\mu A$

Current Limit Comparator I_P
 $T_A = 25^\circ C$

Sense voltage						
PEB 2023	V_{Sense}	90	100	110	mV	$V_S = 40V$
PEF 2323	V_{Sense}	85	100	115	mV	$V_S = 40V$
Input bias current	I_I		-25	-40	μA	$V_{IP} = 0V$
Input voltage range	V_I	0		1	V	
Response time (signal at GA)	t_{Res}		250	500	ns	$I_P = 0 \rightarrow 200mV$

Output Driver GA
 $T_A = 25^\circ C,$

H-output voltage	V_{OH}	4.5		V_{EXT}	V	$I_{Source} = 20mA,$ $V_{EXT} = 6.2V$
L-output voltage	V_{OL}		0.3	0.4	V	$I_{Sink} = 20mA$
Rise time (10% to 90%)	t_r		50	200	ns	$C_L = 800pF,$ $V_{EXT} = 6.2V$
Fall time (90% to 10%)	t_f		50	200	ns	$C_L = 800pF,$ $V_{EXT} = 6.2V$

Electrical Characteristics

DC Characteristics (cont'd)

Parameter	Symbol	Limit Values			Unit	Test Condition
		min.	typ.	max.		

Undervoltage Detection UV, UVx

Start-up threshold 1	$V_{UV\ St1}$	8	10	12	V	supply voltage range 1
Start-up threshold 2,3	$V_{UV\ St2,3}$	18	20	22	V	supply voltage range 2 or 3

External Supply V_{EXT}

Output voltage	V_O	5.8	6.0	6.2	V	
Output current	I_O			2	mA	
Input voltage	V_I	6.2		9	V	
Z-current	I_Z			6	mA	

General Parameters, $T_A = 25^\circ\text{C}$

Power consumption	P_{tot}		5	6	mW	$V_S = 40\text{V}$, $f_{OSC} = 20\text{kHz}$, $C_{L\ GATE} = 470\text{pF}$, $V_{EXT} = 6.2\text{ to }6.7\text{V}$
High impedance input current	I_{HI}			10	μA	„undervoltage“

Note: The listed characteristics are ensured over the operating range of the integrated circuit. Typical characteristics specify mean values expected over the production spread. If not otherwise specified, typical characteristics apply at $T_A = 25^\circ\text{C}$ and the given supply voltage.

4 Package Outlines

Plastic Package, P-DSO-14
(Plastic Dual Small Outline)

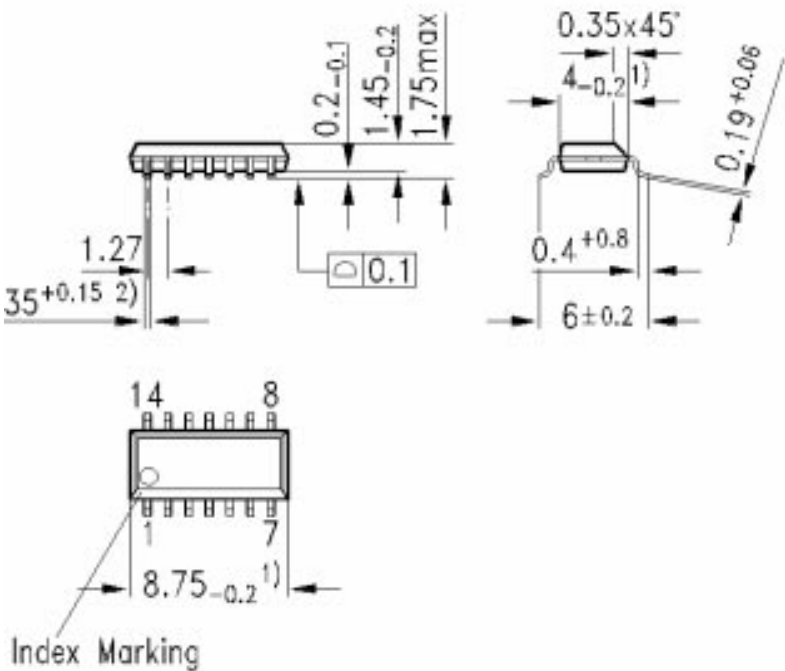

- 1) Does not include plastic or metal protrusions of 0.15 max per side
- 2) Does not include dambar protrusion of 0.05 max per side