

74AHC594; 74AHCT594

8-bit shift register with output register

Rev. 01 — 4 July 2006

Product data sheet

1. General description

The 74AHC594; 74AHCT594 is a high-speed Si-gate CMOS device and is pin compatible with Low-Power Schottky TTL (LSTTL). It is specified in compliance with JEDEC standard No. 7A.

The 74AHC594; 74AHCT594 is an 8-bit, non-inverting, serial-in, parallel-out shift register that feeds an 8-bit D-type storage register. Separate clocks (SHCP and STCP) and direct overriding clears ($\overline{\text{SHR}}$ and $\overline{\text{STR}}$) are provided on both the shift and storage registers. A serial output (Q7S) is provided for cascading purposes.

Both the shift and storage register clocks are positive-edge triggered. If the user wishes to connect both clocks together, the shift register will always be one count pulse ahead of the storage register.

2. Features

- Wide supply voltage range from 2.0 V to 5.5 V
- 8-bit serial-in, parallel-out shift register with storage
- Independent direct overriding clears on shift and storage registers
- Independent clocks for shift and storage registers
- Latch-up performance exceeds 100 mA per JESD 78 Class II
- Input levels:
 - ◆ CMOS levels: 74AHC594 only
 - ◆ TTL levels: 74AHCT594 only
- ESD protection:
 - ◆ HBM JESD22-A114-C exceeds 2000 V
 - ◆ MM JESD22-A115-A exceeds 200 V
 - ◆ CDM JESD22-C101-C exceeds 1000 V
- Specified from $-40\text{ }^{\circ}\text{C}$ to $+85\text{ }^{\circ}\text{C}$ and from $-40\text{ }^{\circ}\text{C}$ to $+125\text{ }^{\circ}\text{C}$

3. Applications

- Serial-to parallel data conversion
- Remote control holding register

PHILIPS

4. Ordering information

Table 1. Ordering information

Type number	Package			Version
	Temperature range	Name	Description	
74AHC594D	-40 °C to +125 °C	SO16	plastic small outline package; 16 leads; body width 3.9 mm	SOT109-1
74AHC594DB	-40 °C to +125 °C	SSOP16	plastic shrink small outline package; 16 leads; body width 5.3 mm	SOT338-1
74AHC594PW	-40 °C to +125 °C	TSSOP16	plastic thin shrink small outline package; 16 leads; body width 4.4 mm	SOT403-1
74AHC594BQ	-40 °C to +125 °C	DHVQFN16	plastic dual in-line compatible thermal enhanced very thin quad flat package; no leads; 16 terminals; body 2.5 × 3.5 × 0.85 mm	SOT763-1
74AHCT594D	-40 °C to +125 °C	SO16	plastic small outline package; 16 leads; body width 3.9 mm	SOT109-1
74AHCT594DB	-40 °C to +125 °C	SSOP16	plastic shrink small outline package; 16 leads; body width 5.3 mm	SOT338-1
74AHCT594PW	-40 °C to +125 °C	TSSOP16	plastic thin shrink small outline package; 16 leads; body width 4.4 mm	SOT403-1
74AHCT594BQ	-40 °C to +125 °C	DHVQFN16	plastic dual in-line compatible thermal enhanced very thin quad flat package; no leads; 16 terminals; body 2.5 × 3.5 × 0.85 mm	SOT763-1

5. Functional diagram

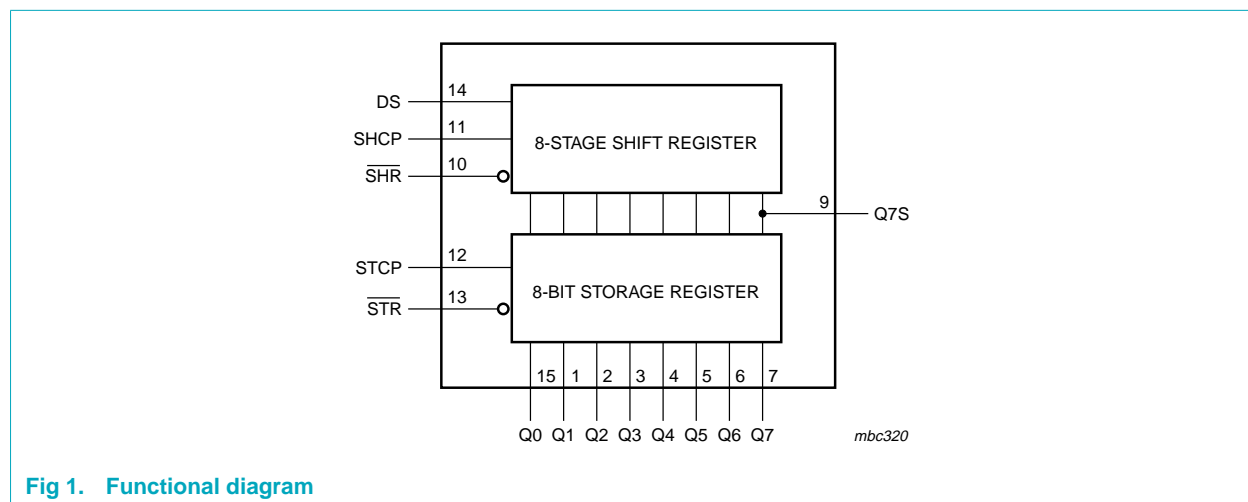

Fig 1. Functional diagram

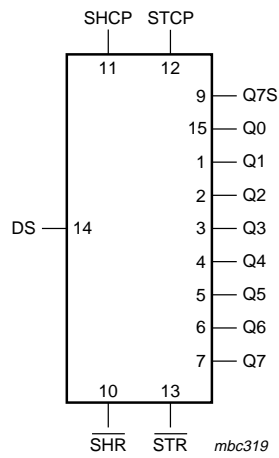

Fig 2. Logic symbol

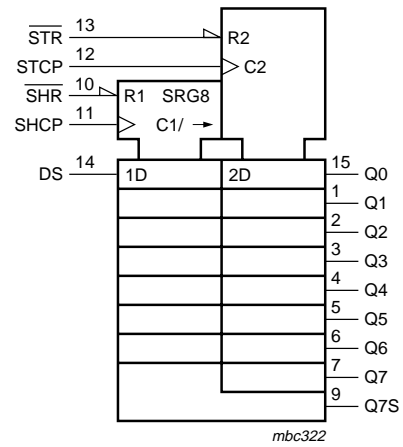

Fig 3. IEC logic symbol

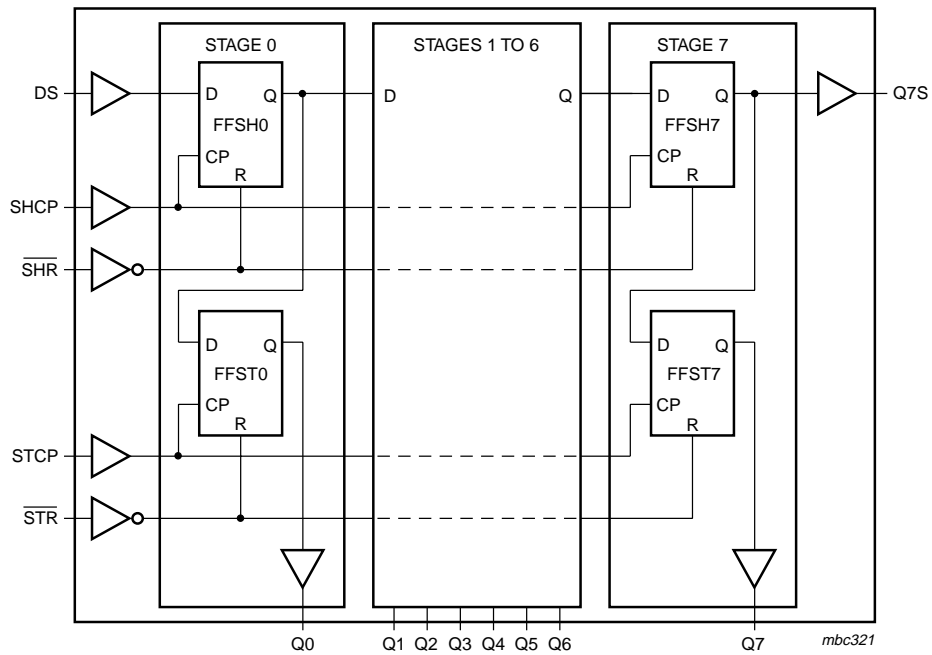

Fig 4. Logic diagram

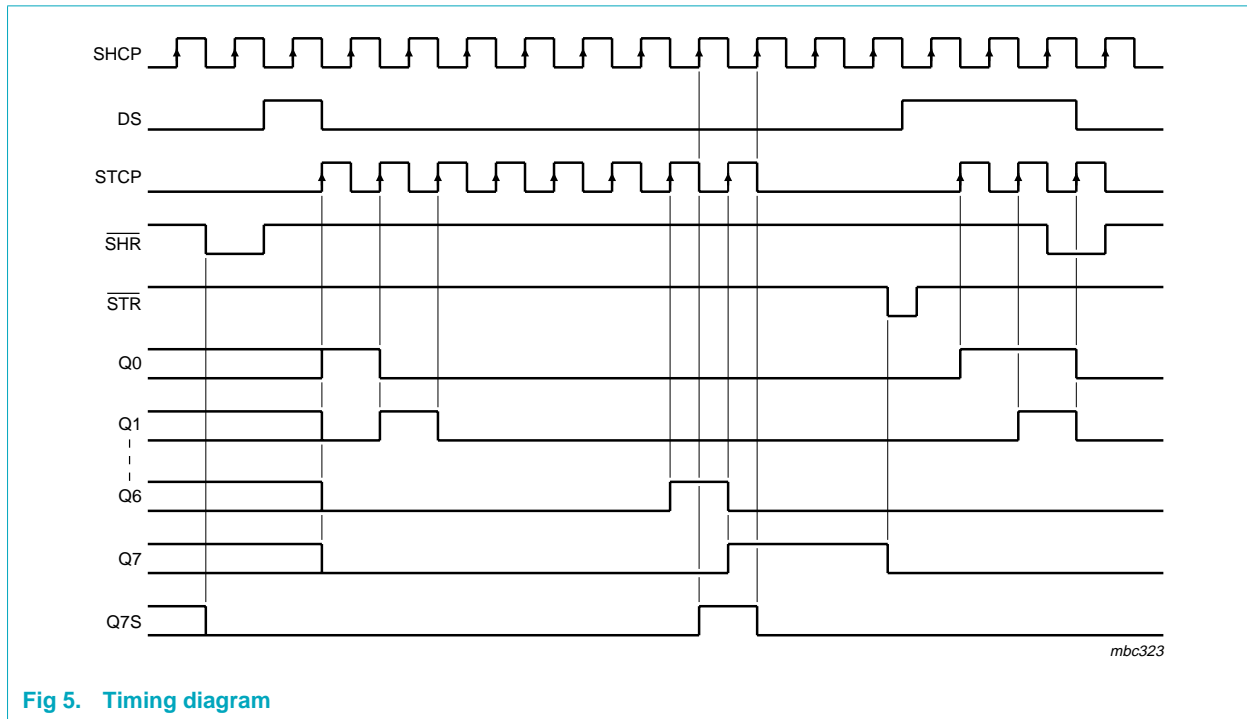

Fig 5. Timing diagram

6. Pinning information

6.1 Pinning

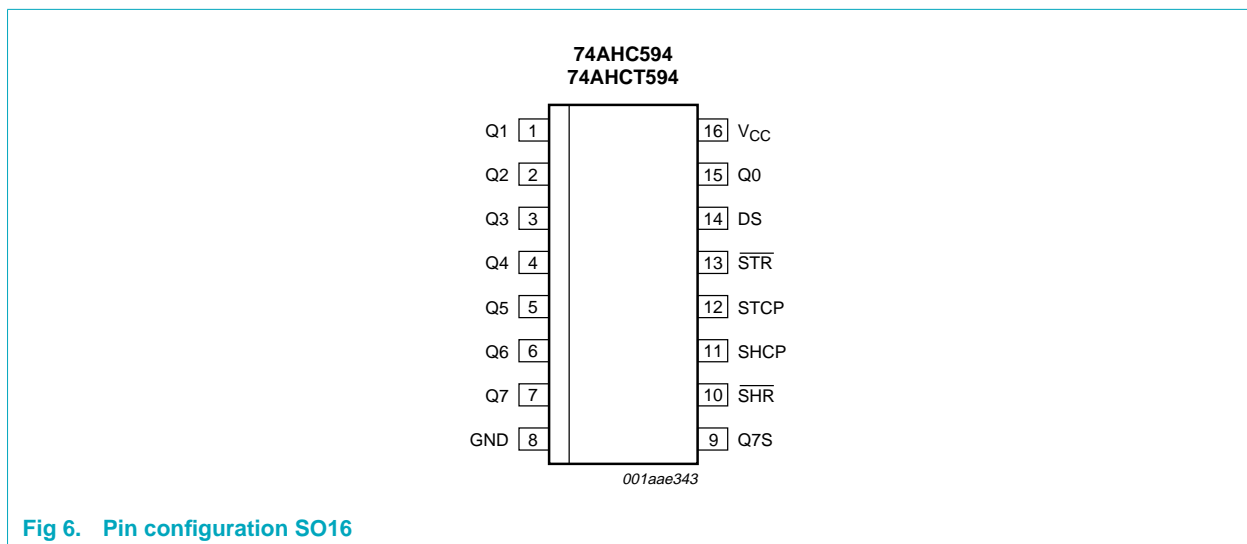
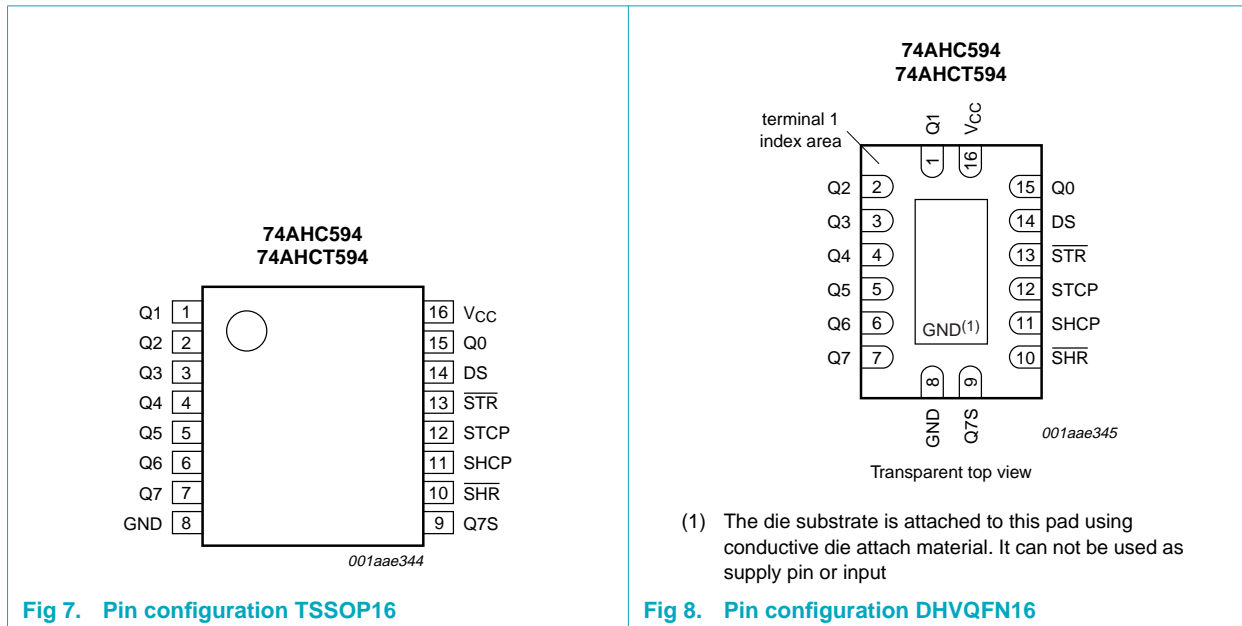

Fig 6. Pin configuration SO16



6.2 Pin description

Table 2. Pin description

Symbol	Pin	Description
Q1	1	parallel data output Q1
Q2	2	parallel data output Q2
Q3	3	parallel data output Q3
Q4	4	parallel data output Q4
Q5	5	parallel data output Q5
Q6	6	parallel data output Q6
Q7	7	parallel data output Q7
GND	8	ground (0 V)
Q7S	9	serial data output Q7S
$\overline{\text{SHR}}$	10	shift register reset $\overline{\text{SHR}}$ (active LOW)
SHCP	11	shift register clock input SHCP
STCP	12	storage register clock input STCP
$\overline{\text{STR}}$	13	storage register reset $\overline{\text{STR}}$ (active LOW)
DS	14	serial data input DS
Q0	15	parallel data output Q0
V _{CC}	16	supply voltage

7. Functional description

Table 3. Function table^[1]

Function	Inputs				
	SHR	STR	SHCP	STCP	DS
Clear shift register	L	X	X	X	X
Clear storage register	X	L	X	X	X
Load DS into shift register stage 0, advance previous stage data to the next stage	H	X	↑	X	H or L
Transfer shift register data to storage register and outputs Qn	X	H	X	↑	X

- [1] H = HIGH voltage level;
 L = LOW voltage level;
 ↑ = LOW-to-HIGH transition;
 X = don't care.

8. Limiting values

Table 4. Limiting values

In accordance with the Absolute Maximum Rating System (IEC 60134). Voltages are referenced to GND (ground = 0 V).

Symbol	Parameter	Conditions	Min	Max	Unit
V_{CC}	supply voltage		-0.5	+7.0	V
V_I	input voltage		-0.5	+7.0	V
I_{IK}	input clamping current	$V_I < -0.5$ V	[1] -	-20	mA
I_{OK}	output clamping current	$V_O < -0.5$ V or $V_O > V_{CC} + 0.5$ V	[1] -	±20	mA
I_O	output current	$V_O = -0.5$ V to $V_{CC} + 0.5$ V	-	±25	mA
I_{CC}	quiescent supply current		-	75	mA
I_{GND}	ground current		-	-75	mA
T_{stg}	storage temperature		-65	+150	°C
P_{tot}	total power dissipation	$T_{amb} = -40$ °C to +125 °C	[2] -	500	mW

- [1] The input and output voltage ratings may be exceeded if the input and output current ratings are observed.
 [2] For SO16 packages: above 70 °C the value of P_{tot} derates linearly with 8 mW/K.
 For (T)SSOP16 packages: above 60 °C the value of P_{tot} derates linearly with 5.5 mW/K.
 For DHVQFN16 packages: above 60 °C the value of P_{tot} derates linearly with 4.5 mW/K.

9. Recommended operating conditions

Table 5. Recommended operating conditions

Symbol	Parameter	Conditions	Min	Typ	Max	Unit
Type 74AHC594						
V_{CC}	supply voltage		2.0	5.0	5.5	V
V_I	input voltage		0	-	5.5	V
V_O	output voltage		0	-	V_{CC}	V
T_{amb}	ambient temperature		-40	+25	+125	°C
$\Delta t/\Delta V$	input transition rise and fall rate	$V_{CC} = 3.3 \text{ V} \pm 0.3 \text{ V}$	-	-	100	ns/V
		$V_{CC} = 5 \text{ V} \pm 0.5 \text{ V}$	-	-	20	ns/V
Type 74AHCT594						
V_{CC}	supply voltage		4.5	5.0	5.5	V
V_I	input voltage		0	-	5.5	V
V_O	output voltage		0	-	V_{CC}	V
T_{amb}	ambient temperature		-40	+25	+125	°C
$\Delta t/\Delta V$	input transition rise and fall rate	$V_{CC} = 3.3 \text{ V} \pm 0.3 \text{ V}$	-	-	20	ns/V

10. Static characteristics

Table 6. Static characteristics type 74AHC594

At recommended operating conditions; voltages are referenced to GND (ground = 0 V).

Symbol	Parameter	Conditions	Min	Typ	Max	Unit
$T_{amb} = 25 \text{ °C}$						
V_{IH}	HIGH-level input voltage	$V_{CC} = 2.0 \text{ V}$	1.5	-	-	V
		$V_{CC} = 3.0 \text{ V}$	2.1	-	-	V
		$V_{CC} = 5.5 \text{ V}$	3.85	-	-	V
V_{IL}	LOW-level input voltage	$V_{CC} = 2.0 \text{ V}$	-	-	0.5	V
		$V_{CC} = 3.0 \text{ V}$	-	-	0.9	V
		$V_{CC} = 5.5 \text{ V}$	-	-	1.65	V
V_{OH}	HIGH-level output voltage	$V_I = V_{IH}$ or V_{IL}				
		$I_O = -50 \text{ } \mu\text{A}$; $V_{CC} = 2.0 \text{ V}$	1.9	2.0	-	V
		$I_O = -50 \text{ } \mu\text{A}$; $V_{CC} = 3.0 \text{ V}$	2.9	3.0	-	V
		$I_O = -50 \text{ } \mu\text{A}$; $V_{CC} = 4.5 \text{ V}$	4.4	4.5	-	V
		$I_O = -4.0 \text{ mA}$; $V_{CC} = 3.0 \text{ V}$	2.58	-	-	V
V_{OL}	LOW-level output voltage	$V_I = V_{IH}$ or V_{IL}				
		$I_O = 50 \text{ } \mu\text{A}$; $V_{CC} = 2.0 \text{ V}$	-	0	0.1	V
		$I_O = 50 \text{ } \mu\text{A}$; $V_{CC} = 3.0 \text{ V}$	-	0	0.1	V
		$I_O = 50 \text{ } \mu\text{A}$; $V_{CC} = 4.5 \text{ V}$	-	0	0.1	V
		$I_O = 4 \text{ mA}$; $V_{CC} = 3.0 \text{ V}$	-	-	0.36	V
	$I_O = 8 \text{ mA}$; $V_{CC} = 4.5 \text{ V}$	-	-	0.36	V	
I_I	input leakage current	$V_I = V_{CC}$ or GND; $V_{CC} = 5.5 \text{ V}$	-	-	0.1	μA

Table 6. Static characteristics type 74AHC594 ...continued

At recommended operating conditions; voltages are referenced to GND (ground = 0 V).

Symbol	Parameter	Conditions	Min	Typ	Max	Unit
I_{CC}	quiescent supply current	$V_I = V_{CC}$ or GND; $I_O = 0$ A; $V_{CC} = 5.5$ V	-	-	4.0	μ A
C_I	input capacitance	$V_I = V_{CC}$ or GND	-	3	10	pF
$T_{amb} = -40$ °C to $+85$ °C						
V_{IH}	HIGH-level input voltage	$V_{CC} = 2.0$ V	1.5	-	-	V
		$V_{CC} = 3.0$ V	2.1	-	-	V
		$V_{CC} = 5.5$ V	3.85	-	-	V
V_{IL}	LOW-level input voltage	$V_{CC} = 2.0$ V	-	-	0.5	V
		$V_{CC} = 3.0$ V	-	-	0.9	V
		$V_{CC} = 5.5$ V	-	-	1.65	V
V_{OH}	HIGH-level output voltage	$V_I = V_{IH}$ or V_{IL}				
		$I_O = -50$ μ A; $V_{CC} = 2.0$ V	1.9	-	-	V
		$I_O = -50$ μ A; $V_{CC} = 3.0$ V	2.9	-	-	V
		$I_O = -50$ μ A; $V_{CC} = 4.5$ V	4.4	-	-	V
		$I_O = -4.0$ mA; $V_{CC} = 3.0$ V	2.48	-	-	V
		$I_O = -8.0$ mA; $V_{CC} = 4.5$ V	3.8	-	-	V
V_{OL}	LOW-level output voltage	$V_I = V_{IH}$ or V_{IL}				
		$I_O = 50$ μ A; $V_{CC} = 2.0$ V	-	-	0.1	V
		$I_O = 50$ μ A; $V_{CC} = 3.0$ V	-	-	0.1	V
		$I_O = 50$ μ A; $V_{CC} = 4.5$ V	-	-	0.1	V
		$I_O = 4$ mA; $V_{CC} = 3.0$ V	-	-	0.44	V
		$I_O = 8$ mA; $V_{CC} = 4.5$ V	-	-	0.44	V
I_I	input leakage current	$V_I = V_{CC}$ or GND; $V_{CC} = 5.5$ V	-	-	1.0	μ A
I_{CC}	quiescent supply current	$V_I = V_{CC}$ or GND; $I_O = 0$ A; $V_{CC} = 5.5$ V	-	-	40	μ A
$T_{amb} = -40$ °C to $+125$ °C						
V_{IH}	HIGH-level input voltage	$V_{CC} = 2.0$ V	1.5	-	-	V
		$V_{CC} = 3.0$ V	2.1	-	-	V
		$V_{CC} = 5.5$ V	3.85	-	-	V
V_{IL}	LOW-level input voltage	$V_{CC} = 2.0$ V	-	-	0.5	V
		$V_{CC} = 3.0$ V	-	-	0.9	V
		$V_{CC} = 5.5$ V	-	-	1.65	V
V_{OH}	HIGH-level output voltage	$V_I = V_{IH}$ or V_{IL}				
		$I_O = -50$ μ A; $V_{CC} = 2.0$ V	1.9	-	-	V
		$I_O = -50$ μ A; $V_{CC} = 3.0$ V	2.9	-	-	V
		$I_O = -50$ μ A; $V_{CC} = 4.5$ V	4.4	-	-	V
		$I_O = -4.0$ mA; $V_{CC} = 3.0$ V	2.40	-	-	V
		$I_O = -8.0$ mA; $V_{CC} = 4.5$ V	3.70	-	-	V

Table 6. Static characteristics type 74AHC594 ...continued

At recommended operating conditions; voltages are referenced to GND (ground = 0 V).

Symbol	Parameter	Conditions	Min	Typ	Max	Unit
V _{OL}	LOW-level output voltage	V _I = V _{IH} or V _{IL}				
		I _O = 50 μA; V _{CC} = 2.0 V	-	-	0.1	V
		I _O = 50 μA; V _{CC} = 3.0 V	-	-	0.1	V
		I _O = 50 μA; V _{CC} = 4.5 V	-	-	0.1	V
		I _O = 4 mA; V _{CC} = 3.0 V	-	-	0.55	V
		I _O = 8 mA; V _{CC} = 4.5 V	-	-	0.55	V
I _I	input leakage current	V _I = V _{CC} or GND; V _{CC} = 5.5 V	-	-	2.0	μA
I _{CC}	quiescent supply current	V _I = V _{CC} or GND; I _O = 0 A; V _{CC} = 5.5 V	-	-	80	μA

Table 7. Static characteristics type 74AHCT594

At recommended operating conditions; voltages are referenced to GND (ground = 0 V).

Symbol	Parameter	Conditions	Min	Typ	Max	Unit
T_{amb} = 25 °C						
V _{IH}	HIGH-level input voltage	V _{CC} = 4.5 V to 5.5 V	2.0	-	-	V
V _{IL}	LOW-level input voltage	V _{CC} = 4.5 V to 5.5 V	-	-	0.8	V
V _{OH}	HIGH-level output voltage	V _I = V _{IH} or V _{IL}				
		I _O = -50 μA; V _{CC} = 4.5 V	4.4	4.5	-	V
		I _O = -8.0 mA; V _{CC} = 4.5 V	3.94	-	-	V
V _{OL}	LOW-level output voltage	V _I = V _{IH} or V _{IL}				
		I _O = 50 μA; V _{CC} = 4.5 V	-	0	0.1	V
		I _O = 8 mA; V _{CC} = 4.5 V	-	-	0.36	V
I _I	input leakage current	V _I = V _{IH} or V _{IL} ; V _{CC} = 5.5 V	-	-	0.1	μA
I _{CC}	quiescent supply current	V _I = V _{CC} or GND; I _O = 0 A; V _{CC} = 5.5 V	-	-	4.0	μA
ΔI _{CC}	additional quiescent supply current	per input pin; V _I = V _{CC} - 2.1 V; other inputs at V _{CC} or GND; I _O = 0 A; V _{CC} = 4.5 V to 5.5 V	-	-	1.35	mA
C _I	input capacitance	V _I = V _{CC} or GND	-	3	10	pF
T_{amb} = -40 °C to +85 °C						
V _{IH}	HIGH-level input voltage	V _{CC} = 4.5 V to 5.5 V	2.0	-	-	V
V _{IL}	LOW-level input voltage	V _{CC} = 4.5 V to 5.5 V	-	-	0.8	V
V _{OH}	HIGH-level output voltage	V _I = V _{IH} or V _{IL}				
		I _O = -50 μA; V _{CC} = 4.5 V	4.4	-	-	V
		I _O = -8.0 mA; V _{CC} = 4.5 V	3.8	-	-	V
V _{OL}	LOW-level output voltage	V _I = V _{IH} or V _{IL}				
		I _O = 50 μA; V _{CC} = 4.5 V	-	-	0.1	V
		I _O = 8 mA; V _{CC} = 4.5 V	-	-	0.44	V
I _I	input leakage current	V _I = V _{IH} or V _{IL} ; V _{CC} = 5.5 V	-	-	1.0	μA
I _{CC}	quiescent supply current	V _I = V _{CC} or GND; I _O = 0 A; V _{CC} = 5.5 V	-	-	40	μA

Table 7. Static characteristics type 74AHCT594 ...continued

At recommended operating conditions; voltages are referenced to GND (ground = 0 V).

Symbol	Parameter	Conditions	Min	Typ	Max	Unit
ΔI_{CC}	additional quiescent supply current	per input pin; $V_I = V_{CC} - 2.1$ V; other inputs at V_{CC} or GND; $I_O = 0$ A; $V_{CC} = 4.5$ V to 5.5 V	-	-	1.5	mA
$T_{amb} = -40$ °C to $+125$ °C						
V_{IH}	HIGH-level input voltage	$V_{CC} = 4.5$ V to 5.5 V	2.0	-	-	V
V_{IL}	LOW-level input voltage	$V_{CC} = 4.5$ V to 5.5 V	-	-	0.8	V
V_{OH}	HIGH-level output voltage	$V_I = V_{IH}$ or V_{IL}				
		$I_O = -50$ μ A; $V_{CC} = 4.5$ V	4.4	-	-	V
		$I_O = -8.0$ mA; $V_{CC} = 4.5$ V	3.70	-	-	V
V_{OL}	LOW-level output voltage	$V_I = V_{IH}$ or V_{IL}				
		$I_O = 50$ μ A; $V_{CC} = 4.5$ V	-	-	0.1	V
		$I_O = 8$ mA; $V_{CC} = 4.5$ V	-	-	0.55	V
I_I	input leakage current	$V_I = V_{IH}$ or V_{IL} ; $V_{CC} = 5.5$ V	-	-	2.0	μ A
I_{CC}	quiescent supply current	$V_I = V_{CC}$ or GND; $I_O = 0$ A; $V_{CC} = 5.5$ V	-	-	80	μ A
ΔI_{CC}	additional quiescent supply current	per input pin; $V_I = V_{CC} - 2.1$ V; other inputs at V_{CC} or GND; $I_O = 0$ A; $V_{CC} = 4.5$ V to 5.5 V	-	-	1.5	mA

11. Dynamic characteristics

Table 8. Dynamic characteristics type 74AHC594 $GND = 0$ V; $t_r = t_f \leq 3.0$ ns; see [Figure 15](#).

Symbol	Parameter	Test conditions	Min	Typ	Max	Unit	
$T_{amb} = 25$ °C^[1]							
t_{PLH}	LOW-to-HIGH propagation delay SHCP to Q7S	$V_{CC} = 3.0$ V to 3.6 V; see Figure 9					
		$C_L = 15$ pF	-	5.2	8.5	ns	
		$C_L = 50$ pF	-	7.4	11.5	ns	
		$V_{CC} = 4.5$ V to 5.5 V; see Figure 9					
		$C_L = 15$ pF	-	3.8	6.3	ns	
		$C_L = 50$ pF	-	4.8	8.0	ns	
t_{PHL}	HIGH-to-LOW propagation delay SHCP to Q7S	$V_{CC} = 3.0$ V to 3.6 V; see Figure 9					
		$C_L = 15$ pF	-	5.5	8.9	ns	
		$C_L = 50$ pF	-	7.4	12.1	ns	
		$V_{CC} = 4.5$ V to 5.5 V; see Figure 9					
		$C_L = 15$ pF	-	4.1	6.7	ns	
		$C_L = 50$ pF	-	5.4	8.8	ns	

Table 8. Dynamic characteristics type 74AHC594 ...continuedGND = 0 V; $t_r = t_f \leq 3.0$ ns; see [Figure 15](#).

Symbol	Parameter	Test conditions	Min	Typ	Max	Unit
t_{PLH}	LOW-to-HIGH propagation delay STCP to Qn	$V_{CC} = 3.0$ V to 3.6 V; see Figure 10				
		$C_L = 15$ pF	-	5.1	8.3	ns
		$C_L = 50$ pF	-	7.3	11.9	ns
		$V_{CC} = 4.5$ V to 5.5 V; see Figure 10				
		$C_L = 15$ pF	-	3.5	5.7	ns
		$C_L = 50$ pF	-	4.8	7.8	ns
t_{PHL}	HIGH-to-LOW propagation delay STCP to Qn	$V_{CC} = 3.0$ V to 3.6 V; see Figure 10				
		$C_L = 15$ pF	-	5.5	9.1	ns
		$C_L = 50$ pF	-	7.3	12.0	ns
		$V_{CC} = 4.5$ V to 5.5 V; see Figure 10				
		$C_L = 15$ pF	-	3.7	6.0	ns
		$C_L = 50$ pF	-	5.2	8.5	ns
t_{PHL}	HIGH-to-LOW propagation delay SHR to Q7S	$V_{CC} = 3.0$ V to 3.6 V; see Figure 13				
		$C_L = 15$ pF	-	5.7	9.5	ns
		$C_L = 50$ pF	-	7.5	12.2	ns
		$V_{CC} = 4.5$ V to 5.5 V; see Figure 13				
		$C_L = 15$ pF	-	4.1	6.7	ns
		$C_L = 50$ pF	-	5.4	8.8	ns
	HIGH-to-LOW propagation delay STR to Qn	$V_{CC} = 3.0$ V to 3.6 V; see Figure 14				
		$C_L = 15$ pF	-	5.8	9.6	ns
		$C_L = 50$ pF	-	7.7	12.5	ns
		$V_{CC} = 4.5$ V to 5.5 V; see Figure 14				
		$C_L = 15$ pF	-	4.1	7.2	ns
		$C_L = 50$ pF	-	5.4	9.4	ns
t_W	pulse width HIGH or LOW SHCP and STCP	$C_L = 50$ pF; see Figure 9 and Figure 10				
		$V_{CC} = 3.0$ V to 3.6 V	6.0	-	-	ns
		$V_{CC} = 4.5$ V to 5.5 V	5.5	-	-	ns
	pulse width HIGH or LOW SHR and STR	$C_L = 50$ pF; see Figure 13 and Figure 14				
		$V_{CC} = 3.0$ V to 3.6 V	5.0	-	-	ns
		$V_{CC} = 4.5$ V to 5.5 V	5.0	-	-	ns
t_{su}	set-up time DS to SHCP	$C_L = 50$ pF; see Figure 11				
		$V_{CC} = 3.0$ V to 3.6 V	3.5	-	-	ns
		$V_{CC} = 4.5$ V to 5.5 V	3.0	-	-	ns
	set-up time SHR to STCP	$C_L = 50$ pF; see Figure 12				
		$V_{CC} = 3.0$ V to 3.6 V	8.0	-	-	ns
		$V_{CC} = 4.5$ V to 5.5 V	5.0	-	-	ns
	set-up time SHCP to STCP	$C_L = 50$ pF; see Figure 10				
		$V_{CC} = 3.0$ V to 3.6 V	8.0	-	-	ns
			$V_{CC} = 4.5$ V to 5.5 V	5.0	-	-

Table 8. Dynamic characteristics type 74AHC594 ...continuedGND = 0 V; $t_r = t_f \leq 3.0$ ns; see [Figure 15](#).

Symbol	Parameter	Test conditions	Min	Typ	Max	Unit
t_h	hold time DS to SHCP	$C_L = 50$ pF; see Figure 11				
		$V_{CC} = 3.0$ V to 3.6 V	1.5	-	-	ns
		$V_{CC} = 4.5$ V to 5.5 V	2.0	-	-	ns
t_{rec}	recovery time SHR to SHCP	$C_L = 50$ pF; see Figure 13				
		$V_{CC} = 3.0$ V to 3.6 V	4.2	-	-	ns
		$V_{CC} = 4.5$ V to 5.5 V	2.9	-	-	ns
	recovery time STR to STCP	$C_L = 50$ pF; see Figure 14				
		$V_{CC} = 3.0$ V to 3.6 V	4.6	-	-	ns
		$V_{CC} = 4.5$ V to 5.5 V	3.2	-	-	ns
f_{max}	maximum frequency SHCP or STCP	$C_L = 50$ pF; see Figure 9 and Figure 10				
		$V_{CC} = 3.0$ V to 3.6 V	80	125	-	MHz
		$V_{CC} = 4.5$ V to 5.5 V	90	170	-	MHz
C_{PD}	power dissipation capacitance	$V_I = \text{GND}$ to V_{CC} ; $V_{CC} = 5$ V; $C_L = 50$ pF; $f_i = 1$ MHz	2 -	55	-	pF
$T_{amb} = -40$ °C to $+85$ °C						
t_{PLH}	LOW-to-HIGH propagation delay SHCP to Q7S	$V_{CC} = 3.0$ V to 3.6 V; see Figure 9				
		$C_L = 15$ pF	2.2	-	9.7	ns
		$C_L = 50$ pF	3.0	-	13.2	ns
		$V_{CC} = 4.5$ V to 5.5 V; see Figure 9				
		$C_L = 15$ pF	1.7	-	7.2	ns
		$C_L = 50$ pF	2.4	-	9.1	ns
t_{PHL}	HIGH-to-LOW propagation delay SHCP to Q7S	$V_{CC} = 3.0$ V to 3.6 V; see Figure 9				
		$C_L = 15$ pF	2.3	-	10.2	ns
		$C_L = 50$ pF	3.0	-	13.9	ns
		$V_{CC} = 4.5$ V to 5.5 V; see Figure 9				
		$C_L = 15$ pF	1.9	-	7.6	ns
		$C_L = 50$ pF	2.5	-	10.1	ns
t_{PLH}	LOW-to-HIGH propagation delay STCP to Qn	$V_{CC} = 3.0$ V to 3.6 V; see Figure 10				
		$C_L = 15$ pF	2.3	-	9.5	ns
		$C_L = 50$ pF	3.3	-	13.6	ns
		$V_{CC} = 4.5$ V to 5.5 V; see Figure 10				
		$C_L = 15$ pF	1.8	-	6.5	ns
		$C_L = 50$ pF	2.6	-	9.0	ns
t_{PHL}	HIGH-to-LOW propagation delay STCP to Qn	$V_{CC} = 3.0$ V to 3.6 V; see Figure 10				
		$C_L = 15$ pF	2.4	-	10.4	ns
		$C_L = 50$ pF	3.2	-	13.8	ns
		$V_{CC} = 4.5$ V to 5.5 V; see Figure 10				
		$C_L = 15$ pF	1.9	-	6.9	ns
		$C_L = 50$ pF	2.6	-	9.7	ns

Table 8. Dynamic characteristics type 74AHC594 ...continued

GND = 0 V; $t_r = t_f \leq 3.0$ ns; see Figure 15.

Symbol	Parameter	Test conditions	Min	Typ	Max	Unit
t_{PHL}	HIGH-to-LOW propagation delay SHR to Q7S	$V_{CC} = 3.0$ V to 3.6 V; see Figure 13				
		$C_L = 15$ pF	2.3	-	10.8	ns
		$C_L = 50$ pF	3.6	-	14.0	ns
		$V_{CC} = 4.5$ V to 5.5 V; see Figure 13				
	HIGH-to-LOW propagation delay STR to Qn	$V_{CC} = 3.0$ V to 3.6 V; see Figure 14				
		$C_L = 15$ pF	2.8	-	11.0	ns
		$C_L = 50$ pF	3.8	-	14.4	ns
		$V_{CC} = 4.5$ V to 5.5 V; see Figure 14				
t_w	pulse width HIGH or LOW SHCP and STCP	$C_L = 50$ pF; see Figure 9 and Figure 10				
		$V_{CC} = 3.0$ V to 3.6 V	6.5	-	-	ns
		$V_{CC} = 4.5$ V to 5.5 V	6.0	-	-	ns
	pulse width HIGH or LOW SHR and STR	$C_L = 50$ pF; see Figure 13 and Figure 14				
		$V_{CC} = 3.0$ V to 3.6 V	5.0	-	-	ns
		$V_{CC} = 4.5$ V to 5.5 V	5.2	-	-	ns
t_{su}	set-up time DS to SHCP	$C_L = 50$ pF; see Figure 11				
		$V_{CC} = 3.0$ V to 3.6 V	3.5	-	-	ns
		$V_{CC} = 4.5$ V to 5.5 V	3.0	-	-	ns
	set-up time SHR to STCP	$V_{CC} = 3.0$ V to 3.6 V	9.0	-	-	ns
		$V_{CC} = 4.5$ V to 5.5 V	5.0	-	-	ns
	set-up time SHCP to STCP	$C_L = 50$ pF; see Figure 10				
t_h	hold time DS to SHCP	$C_L = 50$ pF; see Figure 11				
		$V_{CC} = 3.0$ V to 3.6 V	1.5	-	-	ns
		$V_{CC} = 4.5$ V to 5.5 V	2.0	-	-	ns
t_{rec}	recovery time SHR to SHCP	$C_L = 50$ pF; see Figure 13				
		$V_{CC} = 3.0$ V to 3.6 V	4.8	-	-	ns
		$V_{CC} = 4.5$ V to 5.5 V	3.3	-	-	ns
	recovery time STR to STCP	$C_L = 50$ pF; see Figure 14				
		$V_{CC} = 3.0$ V to 3.6 V	5.3	-	-	ns
		$V_{CC} = 4.5$ V to 5.5 V	3.7	-	-	ns

Table 8. Dynamic characteristics type 74AHC594 ...continued
GND = 0 V; $t_r = t_f \leq 3.0$ ns; see Figure 15.

Symbol	Parameter	Test conditions	Min	Typ	Max	Unit
f_{\max}	maximum frequency SHCP or STCP	$C_L = 50$ pF; see Figure 9 and Figure 10				
		$V_{CC} = 3.0$ V to 3.6 V	70	-	-	MHz
		$V_{CC} = 4.5$ V to 5.5 V	80	-	-	MHz
$T_{\text{amb}} = -40$ °C to $+125$ °C						
t_{PLH}	LOW-to-HIGH propagation delay SHCP to Q7S	$V_{CC} = 3.0$ V to 3.6 V; see Figure 9				
		$C_L = 15$ pF	2.2	-	10.6	ns
		$C_L = 50$ pF	3.0	-	14.3	ns
		$V_{CC} = 4.5$ V to 5.5 V; see Figure 9				
		$C_L = 15$ pF	1.7	-	7.8	ns
		$C_L = 50$ pF	2.4	-	10.0	ns
t_{PHL}	HIGH-to-LOW propagation delay SHCP to Q7S	$V_{CC} = 3.0$ V to 3.6 V; see Figure 9				
		$C_L = 15$ pF	2.3	-	11.0	ns
		$C_L = 50$ pF	3.0	-	15.1	ns
		$V_{CC} = 4.5$ V to 5.5 V; see Figure 9				
		$C_L = 15$ pF	1.9	-	8.2	ns
		$C_L = 50$ pF	2.5	-	11.0	ns
t_{PLH}	LOW-to-HIGH propagation delay STCP to Qn	$V_{CC} = 3.0$ V to 3.6 V; see Figure 10				
		$C_L = 15$ pF	2.3	-	10.6	ns
		$C_L = 50$ pF	3.3	-	14.7	ns
		$V_{CC} = 4.5$ V to 5.5 V; see Figure 10				
		$C_L = 15$ pF	1.8	-	7.1	ns
		$C_L = 50$ pF	2.6	-	9.8	ns
t_{PHL}	HIGH-to-LOW propagation delay STCP to Qn	$V_{CC} = 3.0$ V to 3.6 V; see Figure 10				
		$C_L = 15$ pF	2.4	-	11.3	ns
		$C_L = 50$ pF	3.2	-	15.0	ns
		$V_{CC} = 4.5$ V to 5.5 V; see Figure 10				
		$C_L = 15$ pF	1.9	-	7.5	ns
		$C_L = 50$ pF	2.6	-	10.5	ns

Table 8. Dynamic characteristics type 74AHC594 ...continued

GND = 0 V; $t_r = t_f \leq 3.0$ ns; see Figure 15.

Symbol	Parameter	Test conditions	Min	Typ	Max	Unit
t_{PHL}	HIGH-to-LOW propagation delay SHR to Q7S	$V_{CC} = 3.0$ V to 3.6 V; see Figure 13				
		$C_L = 15$ pF	2.3	-	11.7	ns
		$C_L = 50$ pF	3.6	-	15.2	ns
		$V_{CC} = 4.5$ V to 5.5 V; see Figure 13				
	HIGH-to-LOW propagation delay STR to Qn	$V_{CC} = 3.0$ V to 3.6 V; see Figure 14				
		$C_L = 15$ pF	2.8	-	12.0	ns
		$C_L = 50$ pF	3.8	-	15.6	ns
		$V_{CC} = 4.5$ V to 5.5 V; see Figure 14				
t_w	pulse width HIGH or LOW SHCP and STCP	$C_L = 50$ pF; see Figure 9 and Figure 10				
		$V_{CC} = 3.0$ V to 3.6 V	7.0	-	-	ns
		$V_{CC} = 4.5$ V to 5.5 V	6.5	-	-	ns
	pulse width HIGH or LOW SHR and STR	$C_L = 50$ pF; see Figure 13 and Figure 14				
		$V_{CC} = 3.0$ V to 3.6 V	5.5	-	-	ns
		$V_{CC} = 4.5$ V to 5.5 V	5.7	-	-	ns
t_{su}	set-up time DS to SHCP	$C_L = 50$ pF; see Figure 11				
		$V_{CC} = 3.0$ V to 3.6 V	4.0	-	-	ns
		$V_{CC} = 4.5$ V to 5.5 V	3.5	-	-	ns
	set-up time SHR to STCP	$V_{CC} = 3.0$ V to 3.6 V	9.5	-	-	ns
		$V_{CC} = 4.5$ V to 5.5 V	5.5	-	-	ns
	set-up time SHCP to STCP	$C_L = 50$ pF; see Figure 10				
t_h	hold time DS to SHCP	$C_L = 50$ pF; see Figure 11				
		$V_{CC} = 3.0$ V to 3.6 V	2.0	-	-	ns
		$V_{CC} = 4.5$ V to 5.5 V	2.5	-	-	ns
t_{rec}	recovery time SHR to SHCP	$C_L = 50$ pF; see Figure 13				
		$V_{CC} = 3.0$ V to 3.6 V	5.3	-	-	ns
		$V_{CC} = 4.5$ V to 5.5 V	3.8	-	-	ns
	recovery time STR to STCP	$C_L = 50$ pF; see Figure 14				
		$V_{CC} = 3.0$ V to 3.6 V	5.8	-	-	ns
		$V_{CC} = 4.5$ V to 5.5 V	4.3	-	-	ns

Table 8. Dynamic characteristics type 74AHC594 ...continuedGND = 0 V; $t_r = t_f \leq 3.0$ ns; see [Figure 15](#).

Symbol	Parameter	Test conditions	Min	Typ	Max	Unit
f_{\max}	maximum frequency SHCP or STCP	$C_L = 50$ pF; see Figure 9 and Figure 10				
		$V_{CC} = 3.0$ V to 3.6 V	65	-	-	MHz
		$V_{CC} = 4.5$ V to 5.5 V	70	-	-	MHz

[1] Typical values are measured at nominal V_{CC} .[2] C_{PD} is used to determine the dynamic power dissipation (P_D in μ W): $P_D = C_{PD} \times V_{CC}^2 \times f_i \times N + \sum (C_L \times V_{CC}^2 \times f_o)$ where: f_i = input frequency in MHz; f_o = output frequency in MHz; C_L = output load capacitance in pF; V_{CC} = supply voltage in V;

N = number of inputs switching;

 $\sum (C_L \times V_{CC}^2 \times f_o)$ = sum of outputs.**Table 9.** Dynamic characteristics type 74AHCT594GND = 0 V; $t_r = t_f \leq 3.0$ ns; $V_{CC} = 4.5$ V to 5.5 V; see [Figure 15](#)

Symbol	Parameter	Test conditions	Min	Typ	Max	Unit
$T_{\text{amb}} = 25$ °C^[1]						
t_{PLH}	LOW-to-HIGH propagation delay SHCP to Q7S	see Figure 9				
		$C_L = 15$ pF	-	3.8	6.3	ns
		$C_L = 50$ pF	-	4.8	8.0	ns
t_{PHL}	HIGH-to-LOW and LOW-to-HIGH propagation delay SHCP to Q7S	see Figure 9				
		$C_L = 15$ pF	-	4.1	6.7	ns
		$C_L = 50$ pF	-	5.4	8.8	ns
t_{PLH}	LOW-to-HIGH propagation delay STCP to Qn	see Figure 10				
		$C_L = 15$ pF	-	3.5	5.7	ns
		$C_L = 50$ pF	-	4.6	7.7	ns
t_{PHL}	HIGH-to-LOW propagation delay STCP to Qn	see Figure 10				
		$C_L = 15$ pF	-	3.7	6.1	ns
		$C_L = 50$ pF	-	5.2	8.5	ns
t_{PHL}	HIGH-to-LOW propagation delay SHR to Q7S	see Figure 13				
		$C_L = 15$ pF	-	4.3	7.0	ns
		$C_L = 50$ pF	-	5.4	8.8	ns
	HIGH-to-LOW propagation delay STR to Qn	see Figure 14				
		$C_L = 15$ pF	-	4.5	7.4	ns
		$C_L = 50$ pF	-	5.7	9.4	ns
t_w	pulse width HIGH or LOW SHCP and STCP	$C_L = 50$ pF; see Figure 9 and Figure 10	5.5	-	-	ns
	pulse width HIGH or LOW SHR and STR	$C_L = 50$ pF; see Figure 13 and Figure 14	5.2	-	-	ns

Table 9. Dynamic characteristics type 74AHCT594 ...continuedGND = 0 V; $t_r = t_f \leq 3.0$ ns; $V_{CC} = 4.5$ V to 5.5 V; see [Figure 15](#)

Symbol	Parameter	Test conditions	Min	Typ	Max	Unit
t_{su}	set-up time DS to SHCP	$C_L = 50$ pF; see Figure 11	3.0	-	-	ns
	set-up time SHR to STCP	$C_L = 50$ pF; see Figure 12	5.0	-	-	ns
	set-up time SHCP to STCP	$C_L = 50$ pF; see Figure 10	5.0	-	-	ns
t_h	hold time DS to SHCP	see Figure 11	2.0	-	-	ns
t_{rec}	recovery time SHR to SHCP	$C_L = 50$ pF; see Figure 13	2.9	-	-	ns
	recovery time STR to STCP	$C_L = 50$ pF; see Figure 14	3.4	-	-	ns
f_{max}	maximum frequency SHCP or STCP	$C_L = 50$ pF; see Figure 9 and Figure 10	90	160	-	MHz
C_{PD}	power dissipation capacitance	$V_I = \text{GND to } V_{CC}$; $V_{CC} = 5$ V; $C_L = 50$ pF; $f_i = 1$ MHz	2 -	55	-	pF
$T_{amb} = -40$ °C to $+85$ °C						
t_{PLH}	LOW-to-HIGH propagation delay SHCP to Q7S	see Figure 9				
		$C_L = 15$ pF	1.7	-	7.2	ns
		$C_L = 50$ pF	2.2	-	9.1	ns
t_{PHL}	HIGH-to-LOW propagation delay SHCP to Q7S	see Figure 9				
		$C_L = 15$ pF	1.8	-	7.6	ns
		$C_L = 50$ pF	2.4	-	10.1	ns
t_{PLH}	LOW-to-HIGH propagation delay STCP to Qn	see Figure 10				
		$C_L = 15$ pF	1.8	-	6.5	ns
		$C_L = 50$ pF	2.6	-	8.8	ns
t_{PHL}	HIGH-to-LOW propagation delay STCP to Qn	see Figure 10				
		$C_L = 15$ pF	1.9	-	6.9	ns
		$C_L = 50$ pF	2.6	-	9.7	ns
t_{PHL}	HIGH-to-LOW propagation delay SHR to Q7S	see Figure 13				
		$C_L = 15$ pF	2.4	-	8.0	ns
		$C_L = 50$ pF	2.7	-	10.1	ns
	HIGH-to-LOW propagation delay STR to Qn	see Figure 14				
$C_L = 15$ pF		2.3	-	8.4	ns	
		$C_L = 50$ pF	3.1	-	10.7	ns
t_w	pulse width HIGH or LOW SHCP and STCP	$C_L = 50$ pF; see Figure 9 and Figure 10	6.0	-	-	ns
	pulse width HIGH or LOW SHR and STR	$C_L = 50$ pF; see Figure 13 and Figure 14	5.5	-	-	ns

Table 9. Dynamic characteristics type 74AHCT594 ...continuedGND = 0 V; $t_r = t_f \leq 3.0$ ns; $V_{CC} = 4.5$ V to 5.5 V; see [Figure 15](#)

Symbol	Parameter	Test conditions	Min	Typ	Max	Unit
t_{su}	set-up time DS to SHCP	$C_L = 50$ pF; see Figure 11	3.0	-	-	ns
	set-up time SHR to STCP	$C_L = 50$ pF; see Figure 12	5.0	-	-	ns
	set-up time SHCP to STCP	$C_L = 50$ pF; see Figure 10	5.0	-	-	ns
t_h	hold time DS to SHCP	see Figure 11	2.0	-	-	ns
t_{rec}	recovery time SHR to SHCP	$C_L = 50$ pF; see Figure 13	3.3	-	-	ns
	recovery time STR to STCP	$C_L = 50$ pF; see Figure 14	3.8	-	-	ns
f_{max}	maximum frequency SHCP or STCP	$C_L = 50$ pF; see Figure 9 and Figure 10	80	-	-	MHz
$T_{amb} = -40$ °C to $+125$ °C						
t_{PLH}	LOW-to-HIGH propagation delay SHCP to Q7S	see Figure 9				
		$C_L = 15$ pF	1.7	-	7.8	ns
t_{PHL}	HIGH-to-LOW propagation delay SHCP to Q7S	$C_L = 50$ pF	2.2	-	9.9	ns
		see Figure 9				
t_{PLH}	LOW-to-HIGH propagation delay STCP to Qn	$C_L = 15$ pF	1.8	-	8.3	ns
		$C_L = 50$ pF	2.4	-	11.0	ns
t_{PHL}	HIGH-to-LOW propagation delay STCP to Qn	see Figure 10				
		$C_L = 15$ pF	1.9	-	7.2	ns
t_{PHL}	HIGH-to-LOW propagation delay SHR to Q7S	$C_L = 50$ pF	2.6	-	10.5	ns
		see Figure 13				
t_{PHL}	HIGH-to-LOW propagation delay STR to Qn	$C_L = 15$ pF	2.4	-	8.7	ns
		$C_L = 50$ pF	2.7	-	11.0	ns
t_w	pulse width HIGH or LOW SHCP and STCP	see Figure 14				
		$C_L = 15$ pF	2.3	-	9.2	ns
t_w	pulse width HIGH or LOW SHR and STR	$C_L = 50$ pF	3.1	-	11.7	ns
		see Figure 9 and Figure 10				
t_w	pulse width HIGH or LOW SHCP and STCP	$C_L = 50$ pF; see Figure 13 and Figure 14	6.5	-	-	ns
		$C_L = 50$ pF; see Figure 13 and Figure 14	6.0	-	-	ns
t_{su}	set-up time DS to SHCP	$C_L = 50$ pF; see Figure 11	3.5	-	-	ns
	set-up time SHR to STCP	$C_L = 50$ pF; see Figure 12	5.5	-	-	ns
	set-up time SHCP to STCP	$C_L = 50$ pF; see Figure 10	5.5	-	-	ns
t_h	hold time DS to SHCP	see Figure 11	2.5	-	-	ns

Table 9. Dynamic characteristics type 74AHCT594 ...continued

$GND = 0 V$; $t_r = t_f \leq 3.0 ns$; $V_{CC} = 4.5 V$ to $5.5 V$; see [Figure 15](#)

Symbol	Parameter	Test conditions	Min	Typ	Max	Unit
t_{rec}	recovery time \overline{SHR} to SHCP	$C_L = 50 pF$; see Figure 13	3.8	-	-	ns
	recovery time \overline{STR} to STCP	$C_L = 50 pF$; see Figure 14	4.3	-	-	ns
f_{max}	maximum frequency SHCP or STCP	$C_L = 50 pF$; see Figure 9 and Figure 10	70	-	-	MHz

[1] Typical values are measured at $V_{CC} = 5.0 V$.

[2] C_{PD} is used to determine the dynamic power dissipation (P_D in μW):

$$P_D = C_{PD} \times V_{CC}^2 \times f_i \times N + \sum (C_L \times V_{CC}^2 \times f_o)$$

where:

f_i = input frequency in MHz;

f_o = output frequency in MHz;

C_L = output load capacitance in pF;

V_{CC} = supply voltage in V;

N = number of inputs switching;

$\sum (C_L \times V_{CC}^2 \times f_o)$ = sum of outputs.

12. Waveforms

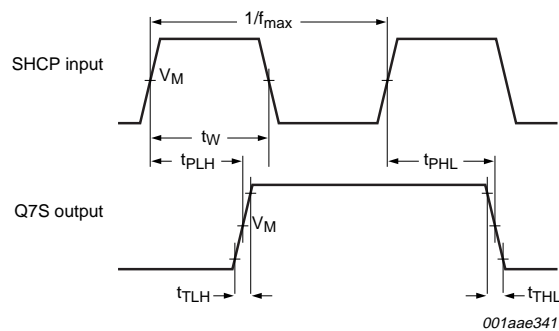

Measurement points are given in [Table 10](#).

V_{OL} and V_{OH} are typical voltage output drop that occur with the output load.

Fig 9. The shift clock (SHCP) to output (Q7S) propagation delays, the shift clock pulse width, and the maximum shift clock frequency

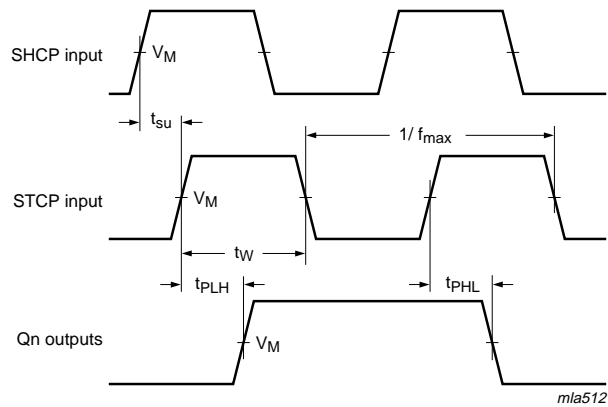

Measurement points are given in [Table 10](#).

V_{OL} and V_{OH} are typical voltage output drop that occur with the output load.

Fig 10. The storage clock (STCP) to output (Qn), propagation delays, the storage clock pulse width, the maximum storage clock pulse frequency and the shift clock to storage clock set-up time

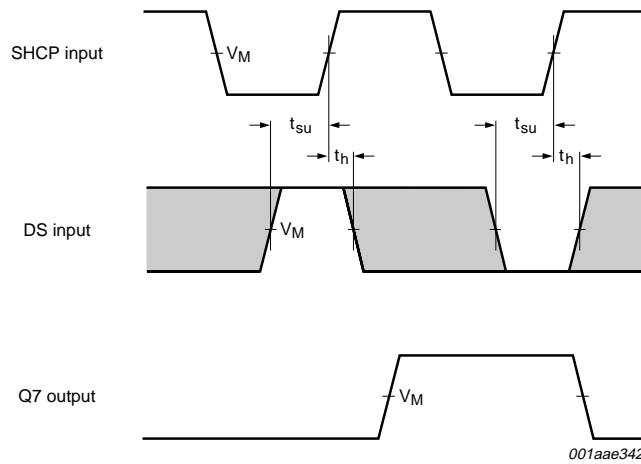

Measurement points are given in [Table 10](#).

The shaded areas indicate when the input is permitted to change for predictable output performance.

V_{OL} and V_{OH} are typical voltage output drop that occur with the output load.

Fig 11. The data set-up time and hold times for DS input to SHCP

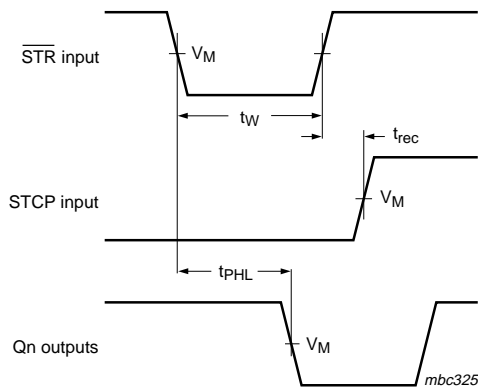

Measurement points are given in [Table 10](#).

V_{OL} and V_{OH} are typical voltage output drop that occur with the output load.

Fig 12. The set-up time shift reset (\overline{STR}) to storage clock (STCP)

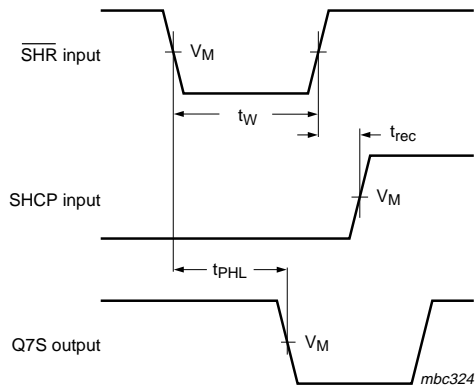

Measurement points are given in [Table 10](#).

V_{OL} and V_{OH} are typical voltage output drop that occur with the output load.

Fig 13. The shift reset (\overline{SHR}) pulse width, the shift reset to output (Q7S) propagation delay and the shift reset to shift clock (SHCP) recovery time

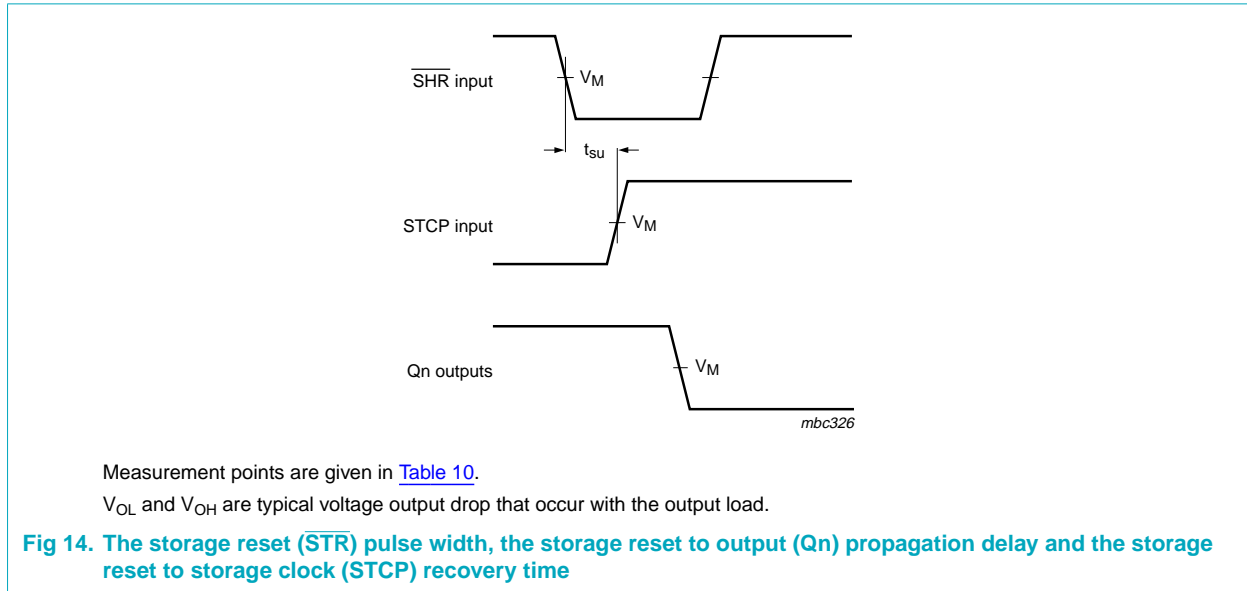

Table 10. Measurement points

Type	Input	Output
	V_M	V_M
74AHC594	$0.5 \times V_{CC}$	$0.5 \times V_{CC}$
74AHCT594	1.5 V	$0.5 \times V_{CC}$

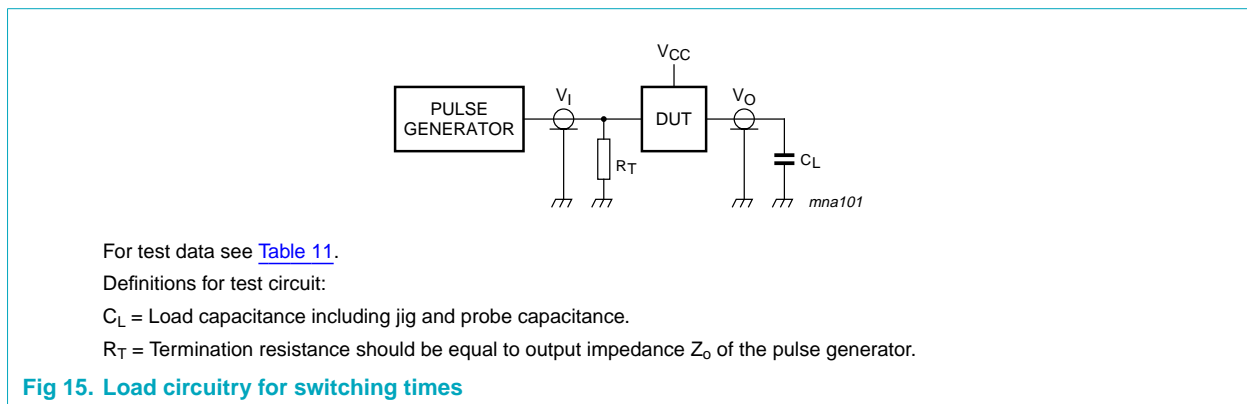

Table 11. Test data

Type	Input		Load	Test
	V_I	t_r, t_f	C_L	
74AHC594	V_{CC}	≤ 3.0 ns	50 pF, 15 pF	t_{PLH}, t_{PHL}
74AHCT594	3.0 V	≤ 3.0 ns	50 pF, 15 pF	t_{PLH}, t_{PHL}

13. Package outline

SO16: plastic small outline package; 16 leads; body width 3.9 mm

SOT109-1

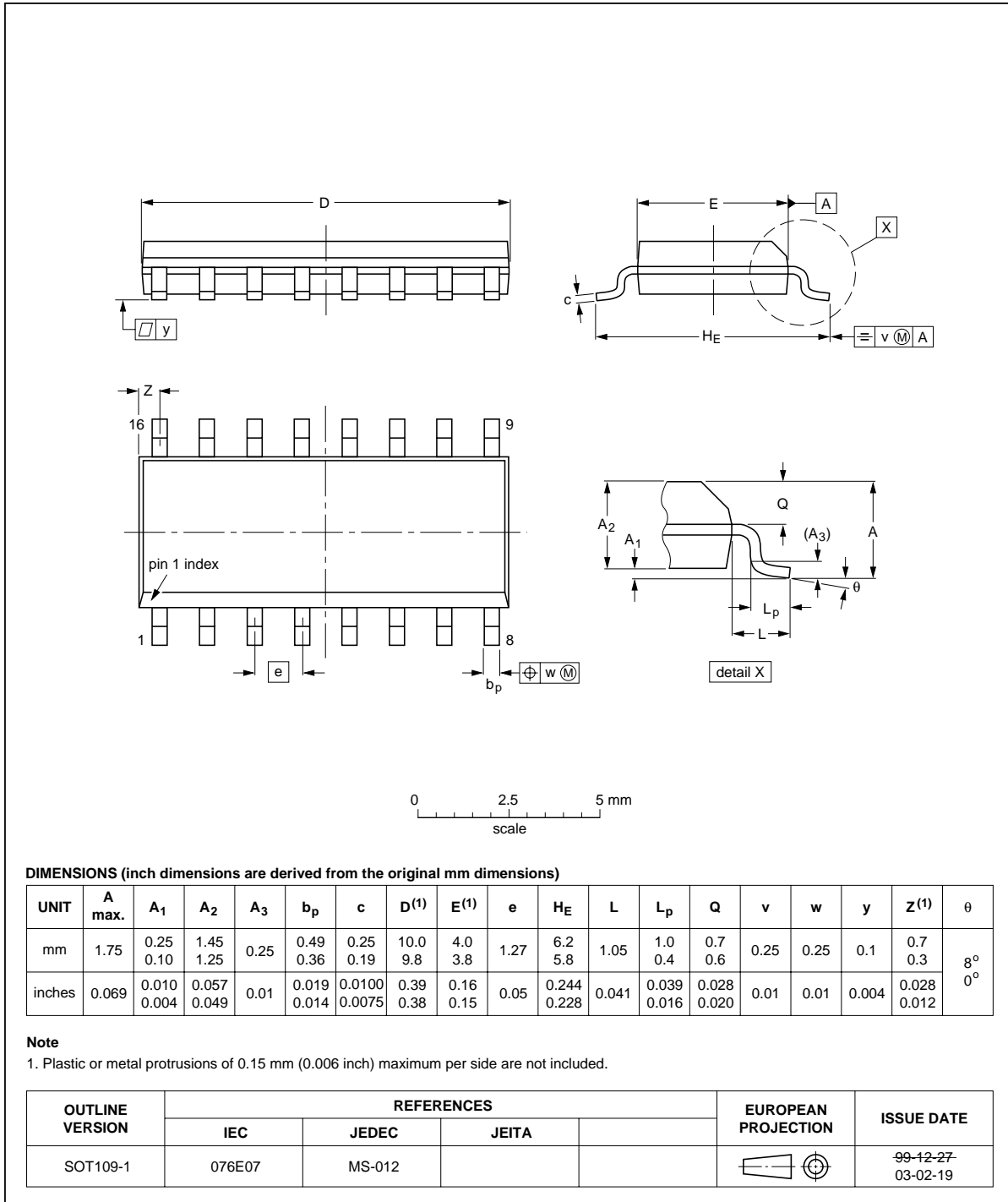

Fig 16. Package outline SOT109-1 (SO16)

SSOP16: plastic shrink small outline package; 16 leads; body width 5.3 mm

SOT338-1

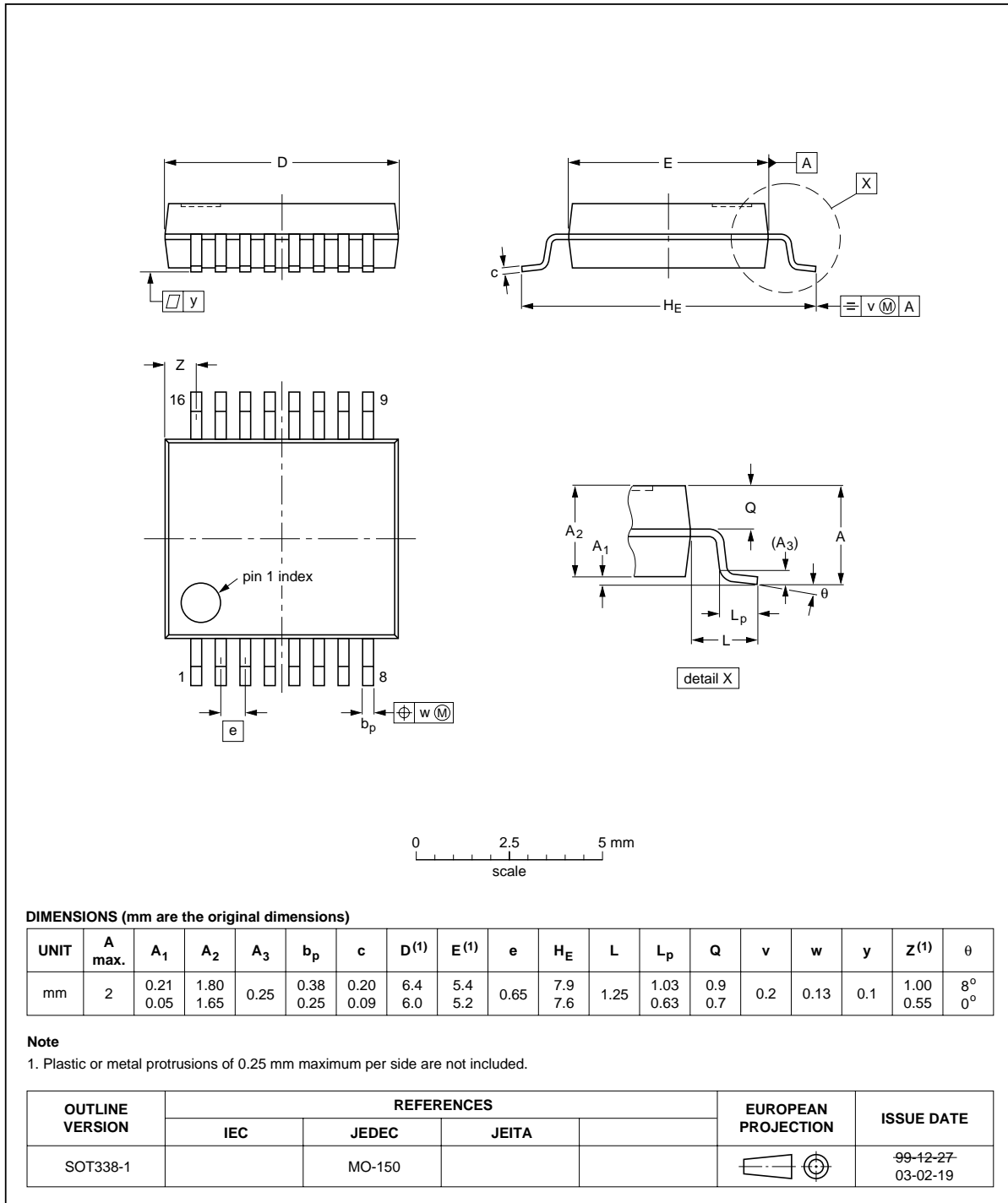

Fig 17. Package outline SOT338-1 (SSOP16)

TSSOP16: plastic thin shrink small outline package; 16 leads; body width 4.4 mm

SOT403-1

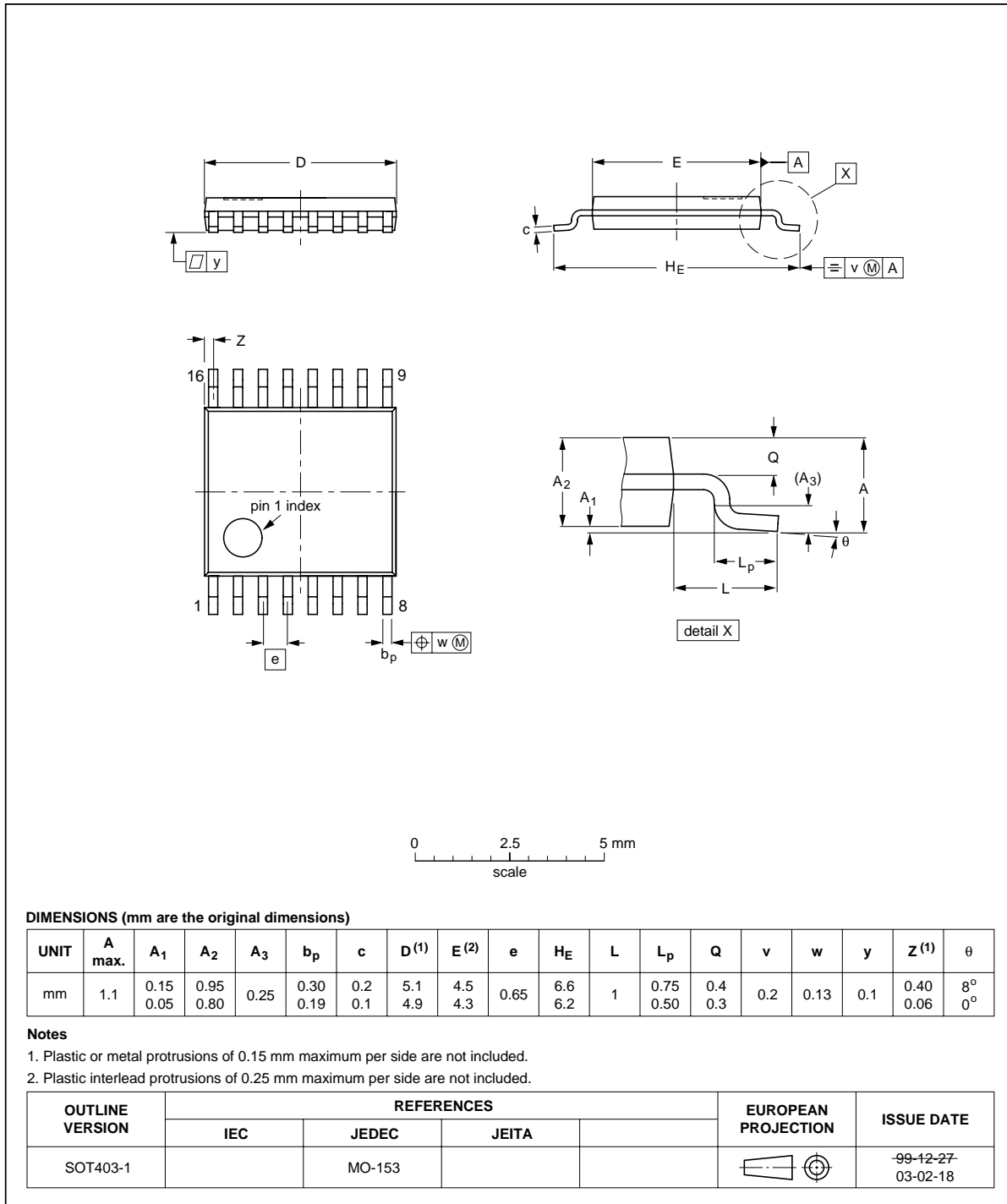

Fig 18. Package outline SOT403-1 (TSSOP16)

DHVQFN16: plastic dual in-line compatible thermal enhanced very thin quad flat package; no leads; 16 terminals; body 2.5 x 3.5 x 0.85 mm SOT763-1

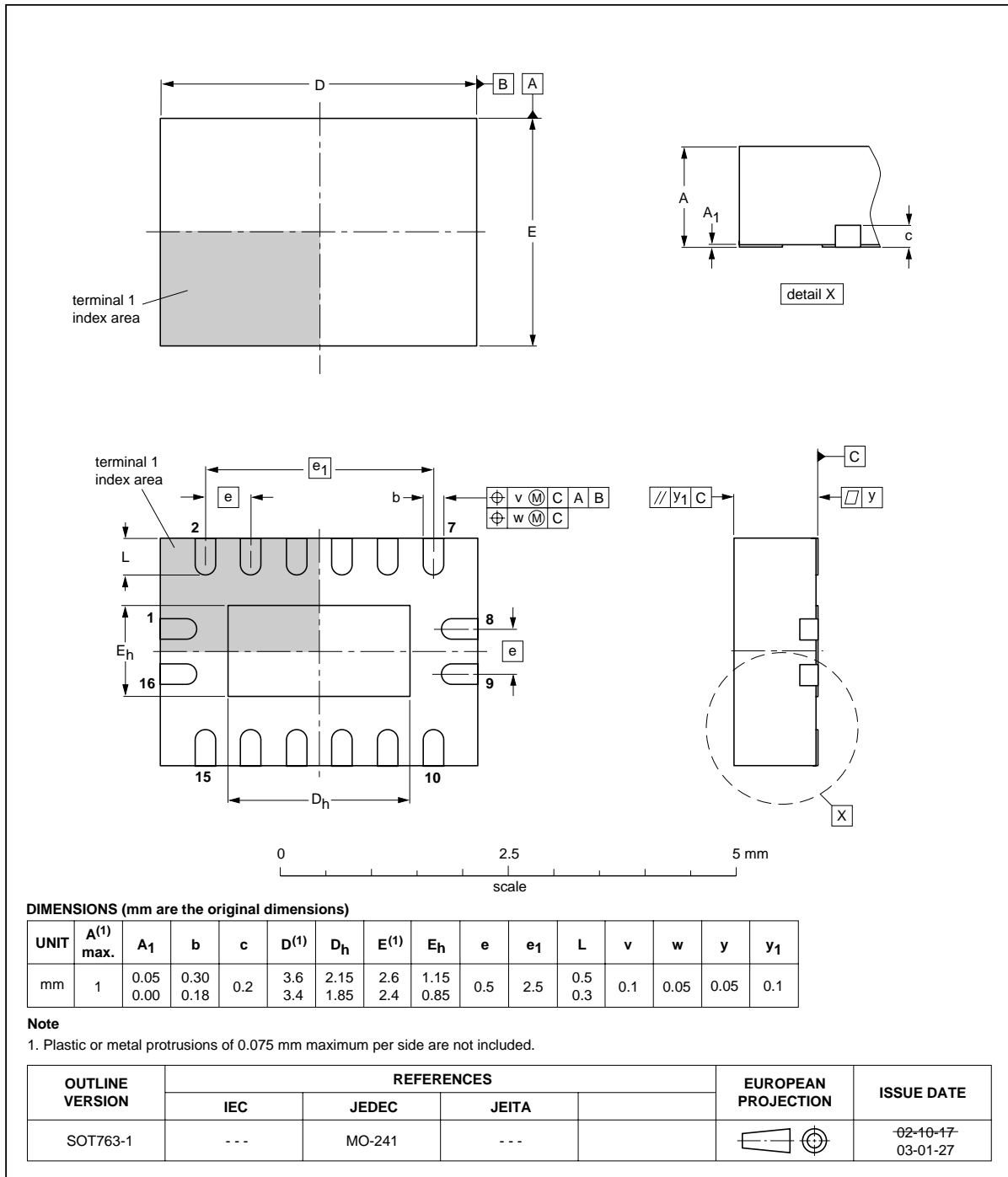

Fig 19. Package outline SOT763-1 (DHVQFN16)

14. Abbreviations

Table 12. Abbreviations

Acronym	Description
CMOS	Complementary Metal Oxide Semiconductor
HBM	Human Body Model
ESD	ElectroStatic Discharge
MM	Machine Model
DUT	Device Under Test

15. Revision history

Table 13. Revision history

Document ID	Release date	Data sheet status	Change notice	Supersedes
74AHC_AHCT594_1	20060704	Product data sheet	-	-

16. Legal information

16.1 Data sheet status

Document status ^{[1][2]}	Product status ^[3]	Definition
Objective [short] data sheet	Development	This document contains data from the objective specification for product development.
Preliminary [short] data sheet	Qualification	This document contains data from the preliminary specification.
Product [short] data sheet	Production	This document contains the product specification.

[1] Please consult the most recently issued document before initiating or completing a design.

[2] The term 'short data sheet' is explained in section "Definitions".

[3] The product status of device(s) described in this document may have changed since this document was published and may differ in case of multiple devices. The latest product status information is available on the Internet at URL <http://www.semiconductors.philips.com>.

16.2 Definitions

Draft — The document is a draft version only. The content is still under internal review and subject to formal approval, which may result in modifications or additions. Philips Semiconductors does not give any representations or warranties as to the accuracy or completeness of information included herein and shall have no liability for the consequences of use of such information.

Short data sheet — A short data sheet is an extract from a full data sheet with the same product type number(s) and title. A short data sheet is intended for quick reference only and should not be relied upon to contain detailed and full information. For detailed and full information see the relevant full data sheet, which is available on request via the local Philips Semiconductors sales office. In case of any inconsistency or conflict with the short data sheet, the full data sheet shall prevail.

16.3 Disclaimers

General — Information in this document is believed to be accurate and reliable. However, Philips Semiconductors does not give any representations or warranties, expressed or implied, as to the accuracy or completeness of such information and shall have no liability for the consequences of use of such information.

Right to make changes — Philips Semiconductors reserves the right to make changes to information published in this document, including without limitation specifications and product descriptions, at any time and without notice. This document supersedes and replaces all information supplied prior to the publication hereof.

Suitability for use — Philips Semiconductors products are not designed, authorized or warranted to be suitable for use in medical, military, aircraft, space or life support equipment, nor in applications where failure or

malfunction of a Philips Semiconductors product can reasonably be expected to result in personal injury, death or severe property or environmental damage. Philips Semiconductors accepts no liability for inclusion and/or use of Philips Semiconductors products in such equipment or applications and therefore such inclusion and/or use is at the customer's own risk.

Applications — Applications that are described herein for any of these products are for illustrative purposes only. Philips Semiconductors makes no representation or warranty that such applications will be suitable for the specified use without further testing or modification.

Limiting values — Stress above one or more limiting values (as defined in the Absolute Maximum Ratings System of IEC 60134) may cause permanent damage to the device. Limiting values are stress ratings only and operation of the device at these or any other conditions above those given in the Characteristics sections of this document is not implied. Exposure to limiting values for extended periods may affect device reliability.

Terms and conditions of sale — Philips Semiconductors products are sold subject to the general terms and conditions of commercial sale, as published at <http://www.semiconductors.philips.com/profile/terms>, including those pertaining to warranty, intellectual property rights infringement and limitation of liability, unless explicitly otherwise agreed to in writing by Philips Semiconductors. In case of any inconsistency or conflict between information in this document and such terms and conditions, the latter will prevail.

No offer to sell or license — Nothing in this document may be interpreted or construed as an offer to sell products that is open for acceptance or the grant, conveyance or implication of any license under any copyrights, patents or other industrial or intellectual property rights.

16.4 Trademarks

Notice: All referenced brands, product names, service names and trademarks are the property of their respective owners.

17. Contact information

For additional information, please visit: <http://www.semiconductors.philips.com>

For sales office addresses, send an email to: sales.addresses@www.semiconductors.philips.com

18. Contents

1	General description	1
2	Features	1
3	Applications	1
4	Ordering information	2
5	Functional diagram	2
6	Pinning information	4
6.1	Pinning	4
6.2	Pin description	5
7	Functional description	6
8	Limiting values	6
9	Recommended operating conditions	7
10	Static characteristics	7
11	Dynamic characteristics	10
12	Waveforms	19
13	Package outline	23
14	Abbreviations	27
15	Revision history	27
16	Legal information	28
16.1	Data sheet status	28
16.2	Definitions	28
16.3	Disclaimers	28
16.4	Trademarks	28
17	Contact information	28
18	Contents	29



Please be aware that important notices concerning this document and the product(s) described herein, have been included in section 'Legal information'.

© Koninklijke Philips Electronics N.V. 2006. All rights reserved.

For more information, please visit: <http://www.semiconductors.philips.com>.
For sales office addresses, email to: sales.addresses@www.semiconductors.philips.com.

Date of release: 4 July 2006

Document identifier: 74AHC_AHCT594_1